

LIBRARY
INTERNATIONAL CENTER FOR CENTRE
FOR GROUND WATER SUPPLY AND
RESEARCH IN INDIA

O. P. Handa

GROUND WATER DRILLING



Co. 212.6 8462
3398

GROUND WATER DRILLING

O. P. HANDA

M.I.E (India) Chartered Engineer (India)

Former Superintending Engineer

Central Ground Water Board

LIBRARY
INDIAN INSTITUTE OF TECHNOLOGY
DELHI
NO: ~~6665~~ 3398
LO: 212.6 846R



OXFORD & IBH PUBLISHING CO.

New Delhi

Bombay

Calcutta

© 1984, O.P. Handa

*Published by Mohan Pramlani for Oxford & IBH Publishing Co.
66 Janpath, New Delhi 110001 and printed at
Vishal Printers, Navin Shahadara, Delhi 110032*

Foreword

Development of ground water resource has undergone a manifold acceleration during the past two decades. Large-scale ground water development programmes, especially with the assistance of Institutional Finance, are being taken up in the country and an expenditure of over Rs. 500 crores is being made on the various schemes. To undertake construction of various abstraction structures, it is essential to employ the most modern drilling equipment available from within the country or from the international market. Drilling, being a costly proposition, it has to be ensured that the machines are used to their optimum capacity because every minute wasted adds to the cost of construction. The book on "Ground Water Drilling" brings out the salient applied aspects, procedures and techniques required to be followed by a field driller in the drilling and completion of water wells. It gives an insight into the various operations connected therewith, measures to check the loss of drilling time as also techniques to bring the highest level in the quality of work. The book would be of immense use not only to the sub-professional drilling staff but also to the qualified management level personnel.

Shri O.P. Handa, the author of the book, has behind him a proven field experience of over 30 years in the profession and by his experience has brought to light the various constraints which a driller may face in the execution of the programme and has in very clear words brought out the corrective and preventive measures, required to carry the programme to a successful end.

I am sure, the book would decidedly be of immense use to all those engaged in the profession of water well drilling.

Chairman
Central Ground Water Board
New Delhi
April, 1984

B.D. PATHAK

Preface

There is tremendous need to explore and prove the vast underground water reservoir in time-bound programme through ground water drilling in a developing country like India. It is equally imperative to meet the demand for water especially during drinking water and sanitation decade as well as to enhance the irrigational potential and industrial demands it is therefore very significant that we should be fully conversant and thorough with drilling techniques, development of wells and pumping tests in the construction of tubewells. Each of these methods has been discussed in the book. The costing of wells both for exploration and deposit works and specifications of all important items in ground water drilling has been added.

Ground water drilling is both an art and way of life to those engaged in this occupation and profession. To an old timer, nothing can take the place than "putting down a hole".

To all those who are engaged in search of this, life-sustaining mineral buried under the earth, this small book is dedicated with faith and earnestness.

I commend this book to the students, the engineers and geologists and all those connected with the drilling of tubewell. I hope they would bear with me if there is any omission. However, I would be failing in my duties if I don't express my heartiest indebtedness to those who assisted me in getting it completed in the shortest time.

O.P. HANDA

Contents

<i>Foreword</i>	iii
<i>Preface</i>	v
1. Introduction	1
2. Ground Water Provinces of India	4
3. Exploration for Ground Water	8
4. Water Well Drilling	15
5. Choice of Drilling Rigs	70
6. Well Logging	76
7. Well Design	81
8. Well Construction	91
9. Well Development Methods	109
10. Ground Water Hydraulics	119
11. Well Test and Drill Stem Test	122
12. Selection of Pumps	141
13. Role of PVC in Well Construction	158
14. Fishing Tools and Practices	162
15. Drilling Specifications	172
16. Costing of Wells	203
Conversion Tables	221
<i>Bibliography</i>	225
<i>Index</i>	229

Introduction

Water occurs below land surface within the zone of saturation and at atmospheric pressure in porous formations. In hard rocks, its occurrence is restricted to weathered and fractured zones. The water derived from precipitation entering the soil increases the moisture content and the additional water drains into the ground. This sub-surface water occurs in the zone of aeration and the zone of saturation. The zone of aeration is partially filled by air and this zone can be further divided into the soil water, intermediate and the capillary zone. The depths vary from place to place and generally gradual transition exists between them. The soil water zone consists of soil and sub-soil from which water returns to the atmosphere by evaporation or transpiration by plants. Water is suspended by molecular attraction. The next zone, namely, the capillary zone, lies below the intermediate zone and above the saturated zone. The amount of water held in this zone depends upon the type of material in which the zone exists. The capillary zone forms a passage for movement of water by gravitation from the surface to the zone of saturation. The saturated zone is also termed as the phreatic zone. The water in the zone of saturation is called 'ground water'. All the porous and open spaces are filled with water in this zone. The thickness of the saturated zone varies from a few metres to hundreds of metres, depending upon the geology, the availability of pore spaces, recharge and movement of ground water. The upper surface of the zone of saturation is known as the water table. Its shape is usually controlled by the surface topography.

A rock formation or groups of formations or material that

contain sufficient saturated permeable material, yielding significant quantities of water is defined as an aquifer. An aquifuge is an impermeable formation neither capable of containing nor transmitting water, i.e., massive granite whereas an aquiclude is poorly permeable formation containing water but not transmitting at rates for economic withdrawal.

Occurrence of ground water in different formations is chiefly controlled by the geologic frame-work like structure, composition and the characteristics of the rock. Majority of the rocks contain interstices or open spaces which control the occurrence of ground water. The nature of these openings, their size, shape, degree of continuity and distribution are not generally uniform. These interstices in the rock may be primary or secondary. The primary openings formed in the igneous and sedimentary rock include intercrystal spaces in igneous rocks and spaces between adjacent grains in the sedimentary rocks. The secondary openings are the result of joints, fractures, solution cavities and rock deformation etc. The secondary openings vary in their shape, size, abundance and degree of interconnection widely. The joints often intersect each other and vary in frequency of occurrence, spacing and tend to become tight as depth increases. The secondary interstices produced by chemical decomposition or solution action in calcareous and carbonate rocks by removing soluble minerals may result in a network of interconnected openings in the rock.

The size, shape and degree of continuity is highly complex in nature. The porosity and permeability are of fundamental importance in the hydrogeological studies. Porosity is the ratio of the total volume of intersticed space or openings in a rock to the total volume of intersticed space and is expressed as percentage. In general, porosity greater than 20 per cent is considered large and porosity of 5 to 20 per cent to be medium and porosity of less than 5 per cent as poor. Porosity of sedimentary rocks depends upon the shape and assortment of grains, cementation and compaction of the rock. A well-sorted sedimentary rock has high porosity while a poorly sorted sedimentary rock has low porosity. In a well-sorted sedimentary rock, porosity may be decreased due to cementation of particles. Due to the presence of fractures and solution cavities, a rock may also be rendered porous.

Permeability is the ability of a material to transmit liquid through an inter-connected porous medium under a potential gradient. It is the property of the medium and is independent of the nature of the liquid. In a rock formation of a relatively uniform character, the permeability is inversely proportional to porosity.

In hydrogeological studies the term coefficient of permeability is commonly used and is expressed as litres per day per sq. metre. Recently the term hydraulic conductivity has now replaced the term coefficient of permeability.

The permeability measurements for hydrogeologic studies can be determined from laboratory measurements of aquifer materials or samples and from field tests.

Transmissivity (KD or T) is the rate at which water is transmitted through a unit width of the aquifer under a unit hydraulic gradient over the entire thickness of aquifer. It replaces the term coefficient of transmissibility in recent years.

The storage coefficient (S) is the volume of water that an aquifer releases or takes into storage per unit surface area of the aquifer per unit change in head. In a confined aquifer, storage is the result of compression of the aquifer and expansion of the contained water when the head or pressure declines during pumping. In the water table or unconfined aquifer, storage (S) is virtually equal to the specific yield (Sy).

The specific yield (Sy) of a rock is the ratio of the volume of water which the rock or soil after saturation will yield under gravity to the volume of the rock and is expressed as percentage of the total volume of the material drained.

Specific retention (Sr) or field capacity of a rock is the volume of water which the rock or soil after being saturated retains in the pore spaces against the force of gravity and expressed as percentage of the total volume of material drained.

In order to obtain appreciably large and optimum quantities of water from an area it is imperative to conduct drilling for ground water by appropriate methods of drilling.

Ground Water Provinces of India

Each continent of the globe is endowed with enough ground water resources. Assessment and delineation of potential areas need systematic and careful planning of hydrologic and hydrogeological studies. It is imperative to describe a broad outline of ground water occurrence, based on geological formation and physiographic features.

Based on the occurrence of physiographic features and geological conditions, India can be divided into three major provinces lying in three major physiographic regions. These may be divisible into sub-provinces. The sub-division of such provinces is a function of the scale of mapping.

A ground water province is conceivable as a small scale mapping unit, while sub-province is a large scale mapping unit.

The three major physiographic zones of India are:

- I) The Extra-Peninsular Region,
- II) The Indo-Gangetic Plain, and
- III) The Peninsular Region.

Based on the hydrogeological conditions, the country has been divided into eight ground water provinces (Taylor, 1959).

- 1) Pre-cambrian Crystalline Province
- 2) Pre-cambrian Sedimentary Province
- 3) Gondwana Sedimentary Province
- 4) Deccan Trap Province
- 5) Cenozoic Sedimentary Province
- 6) Cenozoic Fault Province
- 7) Ganga Brahmaputra Alluvial Province
- 8) Himalayan Highland Province

Ground water province concept has since been revised. Basis of revision of such provinces are the geomorphology and climatic hydrology of an area.

Table 2.1. Ground Water Province and Sub-province

	<i>Age</i>
<i>I) Extra-Peninsular Region</i>	
1) Meta-sedimentary Rock Province	Precambrian
2) Karewas Province	Pleistocene-Recent
3) Bhabar—Tarai Province	Recent
4) Tertiary Sedimentary Rock Province	Miocene-Pleistocene
5) Intermontane "Hollows" Province	Pleistocene-Recent
<i>II) Indo-Gangetic Plain</i>	
1) Ganga Alluvial Province	Recent
2) Brahmaputra Alluvial Province	Recent
<i>III) Peninsular Region</i>	
1) Deccan Basalt Province	Cretaceous to Eocene
2) Gondwana Sedimentary Province	Carboniferous-Jurassic
3) Crystalline Rock Province	Precambrian
4) Coastal Sedimentary Alluvial Province	Mesozoic-Recent
5) Karstic Limestone Province	Precambrian-Cretaceous

I) Extra Peninsular Region

1) META-SEDIMENTARY ROCK PROVINCE

It comprises metamorphosed sedimentaries consisting of phyllites, slates and schistose rocks of the Himalayan region. The permeability of these rocks is a function of cleavage, foliation and schistosity. The yield by dug wells and dug-cum-bore wells is very low. By and large yield potential is $< 5 \text{ m}^3/\text{hour}$. Mostly, the ground water outflow from this province is in the form of springs and seepage which contribute run-off to Himalayan streams.

2) KAREWAS PROVINCE

Karewas in the Kashmir region form plateaux like mounds of clayey formation. The sand beds and glacial boulder beds comprising Karewas are sources of water supply to dug wells and tubewells. Springs of varying magnitude do issue from the Karewa scarps. Karewas are lacustrine deposits which largely

comprise finer sediments. The yield potential of this province varies from 50 to 100 m³/hour.

3) BHABAR-TARAI PROVINCE

Strewn along the foothills of the outer Himalayas is a distinct ground water province extending from Assam in the east to Jammu region in the west. Bhabar constitute coarse material like boulders, cobbles and gravels. Tarai is a finer gradation of 'Bhabar' and constitutes sand and clay beds of varying thickness. The interface between 'Bhabar' and 'Tarai' is marked by a spring line. The former has deeper water table while later has shallow water table condition. The yield potential of Bhabar sub-province and that of Tarai sub-provinces is over 200 m³/hour. Flowing conditions exist in the province.

4) TERTIARY SEDIMENTARY ROCK PROVINCE

These comprise mostly Siwaliks. They have east-west extension in the outer hills of Himalayas. Ground water occurs in the form of springs. Very rarely it is seen to yield water to wells except upper Siwalik horizon of the province which supports water supply by wells and tubewells. It is expected that certain sandstone horizon under favourable topographical and structural situation can yield large water supplies by wells.

5) INTERMONTANE 'HALLOW' PROVINCE

They are 'duns' comprising valley-fills. The deposits comprise all grades of sands, boulders, gravels and clays. The ground water levels of such provinces vary from few metres to as deep as 35 metres. Such 'duns' are Doon Valley, Ponta Valley and Una Valley in the outer Himalayan Region. They yield appreciably large water supplies of the order of 50 to 100 m³/hour by tubewells and wells within 150 metres depth.

II) Indo-Gangetic Plain Province

Largely this province comprises alluvial fills of Ganga and Brahmaputra river systems. These comprise fine to coarse sand aquifers alternating with clay beds as aquicludes. Ground water levels vary from few metres to about 20 metres. This province is the major source of water supply and has the high-

est yield potential. The yield potential is of the magnitude of over $150 \text{ m}^3/\text{hour}$.

III) Peninsular Region

1) DECCAN BASALT PROVINCE

They are fissured type of effusives disposed in the form of flows of varying thickness. They are jointed, fractured and vesicular in nature which account for secondary porosity and permeability to the basalts. They yield water to dug wells and dug-cum-borewells. Yield prospects of the province are of magnitude of 5 to $25 \text{ m}^3/\text{hour}$.

2) GONDWANA SEDIMENTARY PROVINCE

Recent exploration for ground water in the Gondwana formations has necessitated it to be classified as a separate province in view of its distinct and large yield potentials. They yield water supplies of the order of 50 to $200 \text{ m}^3/\text{hour}$.

3) CRYSTALLINE ROCK PROVINCE

Lower half of the peninsular shield region, enclosed between east and west coastal regions and Deccan province in the north is categorised as crystalline rock province. It mostly comprises of granite and gneissic rocks. Such rocks are mostly fractured and weathered which yield good quantities of water by dug wells or dug-cum-borewells. The yield potential of the province is 5 - $25 \text{ m}^3/\text{hour}$.

4) COASTAL SEDIMENTARY—ALLUVIAL PROVINCE

Coastal alluvium of the province is underlain by Cretaceous-Tertiary rock formations. Alluvium and Tertiaries yield large quantities of water by tubewells. Flowing conditions have also been encountered. Yield potential of coastal alluvium is similar to Ganga-plain province.

5) KARSTIC LIMESTONE PROVINCE

In the extra-peninsular India, Triassic limestones are source of springs and rivers. The precambrian limestones yield water to dug wells and tubewells. The yield potential of limestone of shield region is 50 to $200 \text{ m}^3/\text{hour}$.

Exploration for Ground Water

The objective of any ground water investigation is to evaluate the ground water resources or to locate new areas to supplement the existing resources without creating undesired effect on hydrologic cycle. Exploration by drilling is largely the last method and generally involves high expenditure. Prior to the actual drilling and construction of wells, it is necessary to know the nature of aquifers, their potential, water bearing properties, geological characteristics and areal extension of aquifers their quality and quantity.

Various methods have been devised in hydrogeological investigations but no one method is adequate for evaluation in all aspects. The methods and techniques normally employed in ground water investigations are:

- 1) Surface Geological Method,
- 2) Aerial Photo Interpretation,
- 3) Geophysical Methods (Surface/Sub-surface), and
- 4) Test Drilling.

1) Surface Geological Method

This method involves the collection of existing hydrogeological data, preparation of basic geological and hydrogeological maps, delineation of lithological units, occurrence of ground water, water bearing properties of lithological units, position and thickness of aquifer, lateral extension and stratigraphic or structural control.

Information on existing wells, their location, depth of well, depth of water and chemical quality of water is initially collected. Tubewells in the area are studied for yield, drawdown,

lithology of aquifer penetrated and so on. A hydrogeologist collects water level in existing wells and prepares a water table contour map with reference to the mean sea level. Fluctuations in water levels in different seasons are also recorded and a fluctuation map prepared. The water table map gives an idea of the direction of movement of ground water, its hydraulic gradient and its relation to surface water bodies etc. The hydrogeological studies indicate the general conditions and also suggest further methods to be deployed for exploration and ground water resources evaluation.

2) Aerial Photo Interpretation

Aerial photographs are now being widely used in geological mapping, oil exploration, forestry and land use surveys are of immense utility in hydrogeological investigations as well. With the background of geological and existing hydrogeological data, this study can be utilised for both qualitative and quantitative information of a terrain. Aerial photographs provide additional information in respect of geomorphological features, drainage pattern, erosional features, vegetative and land use pattern and presence of springs in an area. Many of the features which cannot be always brought out by ground surveys can be interpreted with the help of photographs, and this increases the efficiency and accelerates the study.

Aerial photographic investigation is the first stage of study in planning strategies for ground water exploration.

Since the water bearing properties and the occurrence of ground water are controlled by the geological features, aerial photographs are of immense value to a hydrogeologist. The igneous, metamorphic and sedimentary rocks, can be very easily demarcated by the texture and tonal changes in an aerial photograph. Joints, fissures and faults appear as linear features. Prominent sets of joints intersecting each other, show a rectangular blocky appearance on the photographs.

In the granite terrain, study of joints and their intersections are the favourable areas for ground water development. Vegetative pattern, marshy and swampy areas along a linear trend, is indicative of shallow water table or high moisture content along such features. Well sites can be located on highly jointed areas in the igneous and metamorphic rocks. The majority of

drainage courses are controlled by the prevailing joints and a study of these is useful. In the schistose rocks, drainage system is generally of a rectangular pattern.

On the aerial photographs, the lithology can be identified by difference in tonal contrasts. In a sedimentary terrain, shales, clays or clastic rocks, show dark tones while the coarse grained and permeable rocks show light photographic tones. Drainage density increases with decreasing resistance to weathering or erosional process.

The alluvial or unconsolidated formations are very easily recognisable in an aerial photograph because of fluvial features such as river terraces, alluvial fans, buried channels and flood plains which form significant keys in ground water studies.

In the extrusive rocks (lava flows) the joint pattern, fractures, fissures and dykes show geometrical pattern. The area of thick soil cover and weathered zone also can be demarcated. In the limestone terrain, the surface and the sub-surface, flows are generally controlled by a joint system. In the Karstic area sink holes can be picked up by pitted appearance of land surface. The gaining and losing phenomena typical of Karstic terrain can be picked up, much more clearly by photo-interpretation than with conventional studies.

After the launching of Landsat (formerly earth resources technology satellite ERTS) satellite in 1972 a new dimension has been added. Scientists from all over the world have been issuing the data sent by the sensors telemetered from space (890 km) to study mineral and petroleum exploration; for undertaking geologic, hydrogeological mapping and for monitoring pollution hazards etc. by a technique of remote sensing. 'Remote Sensing' in which imagery is acquired with a sensor other than (or in addition to) a conventional camera through which a scene is recorded such as by electronic scanning, using radiations outside the normal visual range of the film and camera micro-wave, radar thermal infrared ultra-violet, as well as multispectral techniques are for the purpose of producing conventional maps, thematic maps, resources surveys etc. in fields of agriculture, forestry, geography, geology and others.

The data sent by the satellite system contains immense information for remotely monitoring the earth from outer space. The

infrared imageries find a wide application for future studies, in ground water exploration.

3) Geophysical Methods (Surface/Subsurface)

After the initial hydrogeological appraisal of the area to be investigated has been completed, it is customary to list and decide the geophysical methods which would be applicable to the area. The aim of geophysics is:

- 1) to establish the physical and by correlation the geological control of the area.
- 2) to locate site for test drilling.
- 3) to enable the drilling and testing results to be extended over a large area which otherwise would not have been possible.

The promising sites selected on the basis of hydrogeological surveys should be further confirmed through geophysical surveys.

The geophysical techniques employed are used to detect ground water or to find sub-surface structure controlling ground water.

The geophysical techniques commonly employed in ground water investigation are resistivity surveys and seismic surveys.

RESISTIVITY SURVEY

The resistivity of saturated rock is determined by the porosity of the rock, resistivity (salinity) of the saturated formation and presence of clay. The resistivity survey technique involved passing current through current electrodes and measuring the potential drop between the potential electrodes. The current and potential electrodes are arranged in a line depending upon the placing of the current and the potential electrodes. Two common electrodes configuration used are Schlumberger and Wanner array. Both depth sounding and transversing techniques are used to detect the vertical and lateral changes in resistivity knowing the electrode spacing, current and the measured potential, it is to calculate the apparent resistivity of the section concerned.

Thus, resistivity survey is useful in detecting the thickness of the weathered zone in hard rock and depth to promising water bearing zones and depthwise variation in chemical quality of ground water.

SEISMIC SURVEY

This survey ranks second to resistivity method commonly employed. Their main use is in the mapping of stratigraphic boundaries, i.e., mapping of valley fill and bed rock depths.

The technique involves producing artificial vibration in the earth crust similar to earthquake either by detonating the dynamite charge through shallow holes or by fall of heavy hammer on the earth surface. If the latter method is used the survey is known as Hammer Seismic Survey. If the former is used, it is Normal Seismic Survey.

The seismic vibrations travel in the earth crust through different depths and get reflected or refracted to the earth surface due to density variations in the crust. These waves are picked up by geophones and the time of travel of different type of waves is recorded on the seismograph. Interpretation of seismograph so obtained throws light on different layers lying under the test site.

This survey is used in detecting thickness of sediments overlying bed rock and depth to the bed rock. It is very useful in investigation of valley fill aquifers and also in hard rock areas.

SUB-SURFACE GEOPHYSICAL METHOD

This include well logging by different methods which will be discussed in Chapter 6. They help in precise delineation of aquifer zone and quality of ground water.

4) Test Drilling

Exploratory drilling and aquifer performance tests are the ultimate methods in any ground water investigations. The choice of the drilling rig or equipment depends upon the objective and quantity of water required, geological formations through which wells are to be constructed, the depth and economics of a well structure. Since drilling, construction and development of wells involve high expenditure the final site for a well is selected after taking into consideration field data and interpretation made from hydrogeological surveys. Production wells are constructed by utilising the cable tool, hydraulic rotary (direct or reverse rotary) or an air hammer pneumatic (down-the-hole) rig to the required depth. While drilling, hydrogeo-

logists and drillers play a decisive role and a close co-ordination between the two is of utmost importance. During the process of drilling, it is necessary to collect samples of the strata through which the drilling is progressing at regular intervals and observe changes in lithology or character of the rock, drilling action, and time taken for penetrating every metre of rock formation.

The rate of penetration is of much value to a driller and hydrogeologist as it indicates the character of the material through which drilling is progressing. Also maintenance of discharge of water and record of water levels in the borehole is of utmost importance. After a borehole is drilled and well construction completed, it is developed by compressed air followed by a pump. A preliminary aquifer test is conducted to evaluate the different parameters for determining optimum discharge, transmissivity and storativity etc.

A long duration pumping test is conducted to determine optimum discharge, drawdown and related hydraulic parameters.

With the completion of drilling, the borehole is electrically logged and the result thus observed is compared with the lithological log and the final well assembly consisting of housing, blank and slotted pipes is recommended. After gravel packing, the well is made sand free by running the compressor and pump as the case may be.

Drilling constitutes the final stage in ground water exploration. The following basic type of drills are employed for test drilling and construction of wells:

HAND BORING RIGS

These are managed with casing pipes crab winch and capstan. These are worked manually and good only in sandy formation. These are economically cheaper though time-consuming.

PERCUSSION RIGS

These are suitable for clayish formations and bouldry strata. These drills are provided with engines of adequate horsepower for chisel action of the bit and bailing the cuttings from the hole. These are speedier than hand boring rigs.

ROTARY DRILLS

They are meant for drilling in alluvial and semi-consolidated formations and for virgin areas in connection with exploration programme, by using drilling mud fluid.

REVERSE ROTARY DRILLS

These are meant for drilling and construction of wells in alluvial areas. These are opposite to direct Rotary rigs in principal.

COMBINATION RIGS

Rotary-cum-percussion is the combination method of percussion and rotary drill. It is not practicable to put one drill for one operation and get another drill for second operation.

Combination drill is used so that any drilling operations can be done depending upon the condition of the site. These drills are used generally for alluvial formation comprising bouldery rocks.

DOWN-THE-HOLE HAMMER DRILLS

These are meant for drilling bore hole in hard compact formation. They combine both percussion and rotary action with air media. Sometimes Air Rotary D.T.H. are provided with mud pump for negotiating the overburden.

DIRECT-CUM-REVERSE CIRCULATION RIGS

These are essentially reverse circulation rigs that incorporate features of direct rotary. The rotary table has large hole and wide speed range and extra piston type mud pump is provided. In non-caving alluvial formations, the reverse drill works very fast for large and shallow holes. For caving alluvial and semi-consolidated formation, Direct Rotary Method will be suitable for drilling shallow and deep bores in semi-consolidated alluvial formation.

Water Well Drilling

General

Ground water is receiving greater attention because of successive drought and scarcity conditions. To develop the resource a greater need for drill/bored well has become apparent. At present the work of drilling and boring is being done by central and state agencies or through private tubewell contractors. To cope up with the rising demand it is imperative that the drilling techniques with different types of drills and equipment are properly understood. Discussions on as to how each type of drill operates and step by step procedure required to be adopted would need to be understood to ensure optimum utilisation of equipment and return on investment. Because of the varying need and hydrogeological conditions it is at times difficult to select/evaluate the right type of drill, i.e., best equipment for the right type of job. The operating techniques of various drilling rigs would, therefore, need to be fully understood by the operators to enable them to employ the optimum method of drilling by proper selection of equipment and its use.

There are two main type of drills, to tap underground water aquifer.

- 1) *Percussion drills*, in which the drill tool with bit is raised and lowered for drilling and loosening the material in the hole.

- 2) *Rotary drills*, which use a rotary bit with mud or air media to carry cuttings to the surface.

- 3) Within these broad classifications, various modifications/adaptations are improvised to have different applications, such as Down-the-Hole Hammer Drills with mud/air media, combi-

nation drills, i.e., rotary-cum-percussion and employing the tools of both rotary and percussion (comparison given in Table 4.1).

Drilling is carried out in different types of formations, including alluvial, semi-consolidated and hard rocks, almost covering the entire length of the country.

As the condition of drilling varies from region to region and to meet the diverse job requirements, the selection and choice of equipment depends on a number of factors.

Table 4.1. Comparison of Rotary and Percussion Drills

<i>Percussion</i>	<i>Rotary</i>
1) A more accurate sample of formation is obtained.	A lot of experience is needed to know the exact formation sample.
2) It is possible to test quantity and quality of each stratum as the drilling proceeds.	A test hole can be drilled. If doubtful, it can be abandoned. Side by side testing is not feasible except through special techniques.
3) Less water is necessary (150 to 200 gallons per day).	More water is needed; 2000 to 3000 gallons per day. Where water is scarce, the cost at times comes out to be prohibitive.
4) Cost per ft drilling for relatively shallow wells in un-consolidated formation are cheaper but slow and time consuming.	There is not much cost difference per feet as it takes less time with greater speed.
5) Much lighter and can be transported quickly.	Needs approachability and mobility to shift to site depending on spacing of holes.
6) Works in alluvial and sandy formation but useful in boulder formation.	Drilling can be done in hard/soft formation.
7) If the rocks are fissured there is loss of circulation and it is best suited as it can be cased.	Efficient performance in medium rocks and semi-consolidated formations. Loss of circulation is to be controlled with mud and other materials.
8) Not much suitable for seismic.	Used in Seismograph.
9) Speed of drilling is slow.	Speed of drilling is more.

1) Cost of Equipment

The percussion drill is less costly as compared to rotary drill. Maximum size and depth range of percussion drills is 5 to 18 inches (127 to 460 mm) and up to 1400 ft (427 m) respectively. It would cost Rs. 30 lakhs approximately (depending upon size, equipment and accessories). Power requirement is low. Most of the work is done by gravity. Tools and bits are less costly. Repairs are also cheaper. Bits can be dressed re-used. A low cost wire line can do the work of raising/lowering instead of costly drilling string bits in rotary drills.

Rotary drills with the same size (5 to 18 inches or 127 to 460 mm) and depth range of 1400 ft (427 metres) would cost Rs. 40 lakhs depending upon size, depth and the type of equipment.

Combination drills: Combination rigs of 1500 feet, (percussion 600 feet capacity and Rotary 1500 feet) capacity would cost Rs. 80 to 100 lakhs.

2) Choice of Equipment

The choice of equipment depends on the following factors.

- a) Formations to be drilled.
- b) Whether drilling is to be done in one well, and if it is test well or deposit well.
- c) Relative speed of drilling for performance for time-bound programmes.
- d) Anticipated drilling hazard and bottlenecks.
- e) Approachability to site, in area of operation and shifting of rig and equipment.

The correct evaluation and assessment of these factors would decide as to what drill would be more suited for the given job requirement.

3) Methods Deployed in Water Well Drilling

- a) Percussion/Cable Tool Drill Method
- b) Direct Rotary Method
- c) Reverse Circulation Drilling Method
- d) DTH Drill with Air Media
- e) DTH Drill with Mud and Air Media
- f) Combination Drills (percussion-cum-rotary method).

The choice of drill equipment has direct relation/bearings to the formation to be drilled and it is to be kept in view that

correct drill is selected for the speedy/successful operations for particular job requirement.

4) Mounting

The rigs could be mounted on skids, or on trailer/truck. The mobility requirements are to be assessed, before the choice of mounting is decided for the drill.

5) Source/Supply of Water

The place in whose approximation the drill is to be taken up, the source and availability of requisite requirement of water is to be assured. The percussion drilling needs less water. It needs 100 to 150 gallons of water (378.5 to 568 litres) for eight hours shift for 4 to 6 inches (100 m to 156 m) size hole while the demand for water in rotary drills especially in zone of lost circulation are much bigger and more.

6) Repair Facility

In remote areas, where repair facilities are not existing, percussion drills are the ideal choice. Major repairs are rarer and the usual make-shift repairs, can keep the drill running.

In rotary drills, it is essential that adequate stock of bearings, chains, gears, hydraulic hoses and hydraulic pumps, and parts may be kept handy to ensure timely repairs and uninterrupted operation. The more the shut-down time, the higher would be the cost of drilling. Hence there should be minimum time loss due to breakdown/repairs.

7) Capacity Rating

According to depth, rating and the size of hole, rigs of various capacities are available. Hence from capacity rating angle, the drills can be classified as follows.

	<i>Rotary hole</i> (200 mm)	<i>Percussion hole</i> (200 mm)	<i>DTH hole</i> (150-162 mm)
1) Light up to 150 metres .		—	—
2) Medium 250-457 metres		250 metres	170 metres
3) Heavy 457-850 metres		450 „	300 „

The choice about capacity of drill is governed by the depth and size of hole to be drilled.

8) Drilling Performance

It has direct relation to the equipment being used and the experience and skill of the operator. A number of aspects are to be considered before the choice is affected. The one which gives best operational efficiency, simplicity of operation, performance and lower operating costs, should be procured/selected.

9) Formation Test and Well Development

Uncontaminated and accurate samples are obtainable with percussion drills. It is possible for driller to collect information on quantity and quality of each strata as drilling proceeds. Brackish water zone can be shut-off completely while in rotary drilled wells, the water comes from all horizons due to gravel envelope unless the suspected zones are cement sealed and shut-off.

10) Choice of Formation

The choice of formation sand, clay, gravel and hard rock has a direct effect on the drill and equipment to be selected.

At deeper depths, the percussion drills become less efficient than rotary drills. But in a rotary drilled well, the high costs and operating costs are duly compensated.

11) Labour Costs

There is not much difference on the cost incurred due to labour or any of the drills: percussion or rotary because of a set of norms of staff pattern posted on the drills. Rotary driven drills need a lesser staff per shift for getting operational efficiency/safety. In India, when not much mechanical handling facilities are provided, work is done normally, with large crew, available. Such pattern of work is only feasible under the existing pattern, provided there is full utilisation.

Percussion drill staff can be trained in lesser time to run the machine. Because of rugged simple construction, incorrect or faulty procedure can be tolerated to some extent, while in rotary drills, the careless and inexperienced operation can damage the costly machine and create other complications. Rotary bits can be damaged through improper use. Rotary bits are 10 to 20 times costlier than percussion bits. Rotary bit costs would amount enormously when used in hard rock etc.

12) Terrain

Percussion drills have less move-in costs and suited for rough hill terrain and boulder formation. These can be used in location with less accessibility. Cable Tools can be used in broken formation, while rotary drill would face water loss circulation problems.

13) Quality of Water

The quality of water is not critical for any machine. Fresh water makes the best rotary drilling mud, but any water can be used. Sea water can be used in rotary wells, though it is hard on equipment/tools, but still the wells can be drilled. In spudder machine, the sea water can be used. The salt in solution, prevents the dispersion or suspension of clay.

PLANNING WORK PROGRAMME

For efficient planning and implementation of drilling work programme it is important that the requirement of time for each activity of drilling is defined to achieve optimum utilisation of individual rig. Flow charts indicating the activity and the time required for the construction of different type of wells by deploying appropriate type of machines have been prepared (see flow charts a to e).

By scheduling the activities according to the time frame indicated in the flow charts, it would be possible to achieve the optimum utilisation of the drilling rigs with the desired efficiency and achieve quality results.

DRILLING FLUIDS

Mud

Every operation that is performed in the hole, i.e., drilling/coring and logging etc., it is in some manner or the other dependent on the nature of drilling fluid.

To have the hole drilled without resorting to casing programme, it is essential and of paramount importance that the drill cuttings be lifted from the hole, in a systematic way. The means are to be found out for supporting the walls of the hole and to prevent caving. The mud laden fluid is defined as mixture

a) FLOW CHART SHOWING THE ACTIVITIES OF DRILLING CREW
DURING CONSTRUCTION OF A BORE HOLE BY ROTARY DRILLING

<i>Symbol</i>	<i>Description</i>
A	Pin-pointing of sites (Site selection).
X	Change of site.
B1	Shifting of surplus stores from the earlier site.
B2	Shifting of meagre staff.
B3	Preparation of approach road to the site for rig shifting.
B4	Shifting of necessary stores like drill rods, pipes, bentonite, camp equipment etc.
Y	Change of location due to abandoning of borehole.
B'1	Shifting of rig.
B'2	Shifting of mud pump.
B'3	Shifting of other ancillary equipment.
C1	Mud pit digging.
C2	Rig levelling.
C3	Mast Raising.
C4	Arrangements for accessories.
C5	Fitting of pump at water source.
C6	Mud mixing.
D1	Drilling through the overburden.
S	Surface pipe fitting.
D2	Pilot hole drilling.
G	Formation sample collection.
I	Mud checking and mud mixing.
E	Electrical logging.
F	Fishing.
Z	Well abandoned.
K	Preliminary Yield Test.
P2	Borehole cleaning.
D3	Reaming
M	Assembly fabrication.
N	Assembly lowering.
W	Gravel shrouding.
P	Borehole washing and jetting.
Q	Development by compressor.
R	Development by pump.
T	Test (Aquifer Performance Test & Step Drawdown Test).
V	Checking verticality of the borehole.
U	Capping of the well.
H	Handing over of the well.

b) FLOW CHART
DURING CONSTRUCTION OF A TUBEWELL BY ROTARY DRILLING

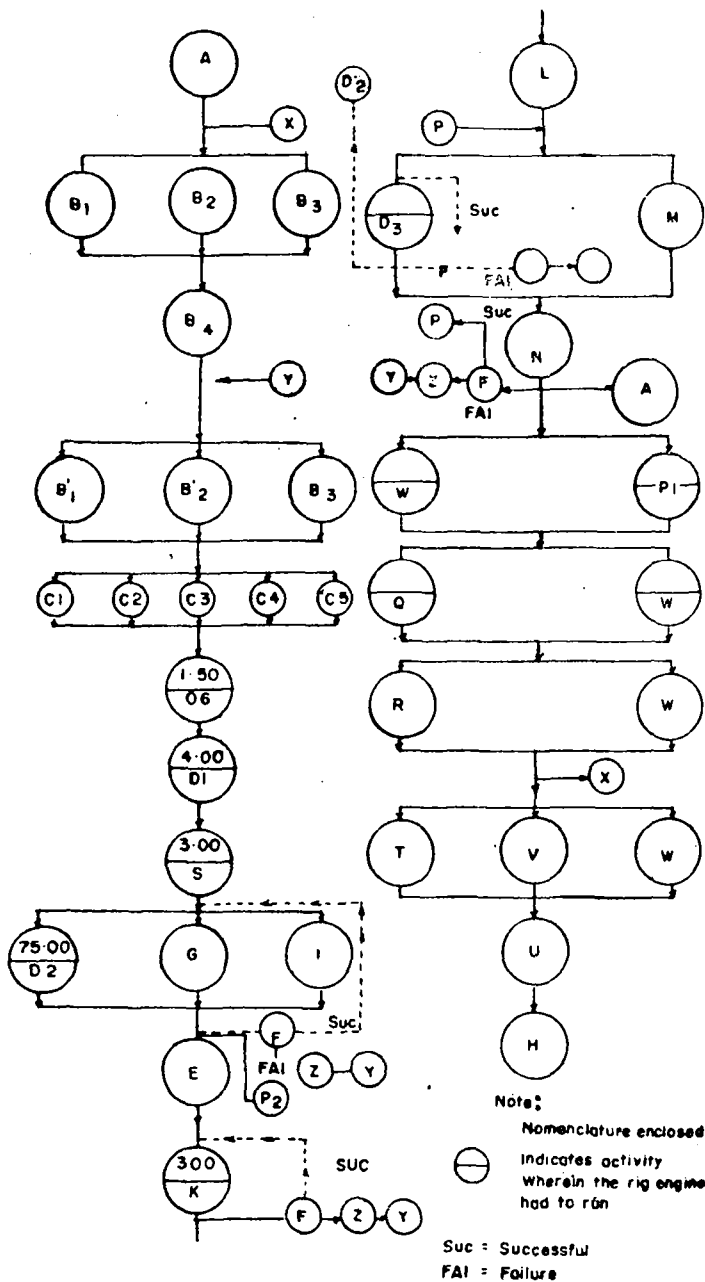

c) **FLOW CHART FOR CONSTRUCTION OF WELLS BY DOWN-THE-HOLE HAMMER RIG**

This gives the sequence of operation and the average number of days required for the successful completion of each activity in respect of exploratory and observation wells, slim holes and production wells.

Activities	No. of Days Required		Observation Well/ Slim Holes
	Exploratory Well	Deposit* Well	
A	4 Days	4 Days	4 Days
X			
B1			
B2			
B3	1 Day	1 Day	1 Day
B4			
Y			
B'1			
B'2	5 Days	4 Days	5 Days
C1			
C2			
C3			
C4	1 Day	1 Day	1 Day
D1			
D2			
D3			
E	1 Day	1 Day	1 Day
K	11 Days	10 Days	11 Days
Q			
N			
	5 Days	2 Days	3 Days
	16 Days	12 Days	14 Days
Holiday	3 Days	2 Days	3 Days
Break Down and Repairs.	2 Days	2 Days	2 Days
	21 Days per well	16 Days per well	19 Days** per well

*Production well

**Include Idle Days

(d) FLOW CHART FOR EXPLORATORY WELLS, DEPOSIT WELLS, OBSERVATION WELL AND SLIM HOLES BY DIRECT ROTARY RIG AND REVERSE ROTARY RIG

This chart gives the comparison of activities in number of days utilised for completion of well drilled by direct rotary and reverse rotary.

Direct Rotary		Reverse Rotary			
Rig	Activities	No. of days	Activities	OW SH	Exploratory Well Deposit*
	EW	DW			No. of Days
A			A		
X			—		
B1			—		
B2			—		
B3	7	4	—		
B4			—		
Y			—		
B'1			—		
B'2			B'1	1	1
B'3			B'2		
			B'3		
C1			C1		
C2	3	3	C2		
C3			C3	3	2
C4			C4		
C5			C5		
C6			C6		
D1			D1		
S			S		
D2			D2	4	4
G	4	3	G		
I			I		
E	1	1	E	1	—
F			F		
Z			—		
K	4	—	—		
P2			—		
D3	7	4	D3	3	—
M	2	2	M		
N			N	2	2
W	1	1	W		9 Days
P1	7	2	P1	4	1
Q			C		
R			—		
T			—		
V			—		1
U			—		
H			—		
		36	20 Days	18 Days	11 Days.

EW = Exploratory Well
 DW = Deposit Well
 *Production Well

OW = Observation Well
 SH = Slim Hole

e) ABSTRACT

The final abstract in number of days required for drilling exploratory wells, deposit wells, and slim holes by direct rotary rig and the similar position in respect of exploratory wells and deposit wells drilled by reverse rotary drill.

<i>Direct Rotary Rig</i>	<i>Reverse Rotary Rig</i>
<i>Exploratory Well</i>	<i>Exploratory Well/Deposit Well</i>
36 Working Days	Working Days 9
6 Holidays	Break Down/ 2
1 Waiting interpretation of log chart and assembly recommendation	Repair
2 Servicing & Minor Repairs	11 Days
45 Days	
<i>Deposit Well</i>	
20 Working Days	
3 Holidays	
1 Minor Repair & Servicing	
24 Days	
<i>Observation Well/Slim Holes</i>	
18 Working Days	
1 Servicing & Minor Repairs	
3 Holidays	
22 Days	

Note: Activities to be taken up as and when required according to exigencies of operations.

of water with any clayey material, which will remain suspended in water for a considerable length of time and is free from sand, lime and cuttings. It could be anything from muddy water to skilfully prepared viscous mixture of water and gel forming clay.

It should have proper density, so that it keeps the cuttings in suspension when the pumps are stopped and yet allows them to settle, when brought out in the settling pits on the surface. It enables the hole to be drilled, through zones of high, medium or normal pressures.

It should be of adequate strength to offset the pressure that may be coming forth from water bearing strata and yet prevent the caving and sloughing of hole.

The mud weight and viscosity must be capable of maintaining mud-cake and it must have the physical properties to be worked, with mud pump fitted with direct rotary.

It has naturally resulted in evolving out chemically treated agent to increase the mud viscosity and prevent the weighting material to settle down.

Classification of drill muds can be done in two systems, namely, Water base and Oil base.

Water based muds are more exclusively used for water well drilling, while oil based muds are used for oil explorations. The first split in the classification of water based muds is based on salinity phase, since Bentonite is capable of dissolving solids up to certain extent. Beyond that, its properties are affected by water based fluids in which Bentonite gives satisfactory service. These are known as non-saline fluids. The fresh water is the basically and universally accepted mud system.

Specifications of mud have been described under the chapter "Drilling Specification".

Functions and Purpose of Drilling Mud

- 1) Removes the cutting from the well and thus speeds up the drilling operations by keeping the bottom of the hole clean.
- 2) Cools and lubricates the drill pipe and oil bearings of mud pump. This results in speedier penetration and safer drilling against stuck up drill pipe, expensive fishing job and even loss of well.
- 3) Supports the walls of the hole by preventing caving and sloughing so that the operation can be continued to the full

depth, before lowering assembly. It helps in providing light coating of mud cake.

4) Enables proper identification of drill cuttings or any show of water bearing or gas/oil strata.

5) Does not impair permeability of any gas/oil/water bearing formations.

6) Helps in the maintenance and preservation of hole already drilled.

7) Prevents caving of formation and controlling the disintegration of certain type of sedimentary rocks.

8) Prevents drill pipe corrosion and fatigue.

9) Scales off bore hole to reduce fluid loss.

10) Provides a contact medium, for any logging operations.

Mud-testing Procedure

The purpose of testing mud is to determine its ability to perform certain necessary functions.

There are a series of tests which are designed to indicate whether mud is capable of performing these functions properly. Since the effectiveness of mud is determined by these tests, the discussions of drilling fluid, is best introduced by review of these testing methods.

- 1) Mud Density (Mud weight).
- 2) Viscosity (the measure of internal resistance to flow).
- 3) Gel strength or shear.
- 4) Filtration property.
- 5) Sand content.
- 6) pH value.

DENSITY

Density is the weight per unit volume of solid or liquid. It determines the hydrostatic pressure, which the mud will exert at any particular depth. Density is measured in any of the following units: gms/cu—cm, weight in pounds per gallon, weight in pounds per cubic ft, weight in pounds per hundred feet of head.

The mud weight of fluid entering the hole, and of it on the return journey, is to be occasionally checked. This can be done by a mud balance (Fig. 4.1).

Weight of the substance relative to equal volume of water

both measured in the same units of mass/volume gives specific gravity.

SPECIFIC GRAVITY

$$\begin{aligned} \text{SG} &= \frac{\text{The weight of mud in calibrated cup}}{\text{The weight of equal volume of water}} \\ &= \frac{\text{Mud weight of cup}}{\text{Water weight of cup}} \end{aligned}$$

Density can be directly read on the mud balance. The device has cup at one end of mud balance beam and sliding weight on

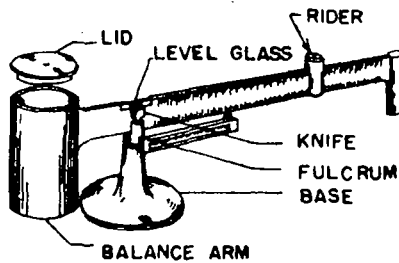

Fig. 4.1. Diagram of Mud Balance

the other portion of the beam. When exactly filled, the cup holds fraction of gallon of fluid. The balance arm is calibrated in pounds per gallon. The position of sliding weight when it is just balanced, indicates, the mud weight/density (Table 4.1).

Table 4.1. Mud Weight Conversion Table

<i>Lbs./Sq. Inch 100 ft. depth</i>	<i>Lbs./Gal.</i>	<i>Lbs cu. ft.</i>	<i>Specific gravity gm/CC</i>
45	8.7	64.8	1.04
48	9.2	69.1	1.11

For ground water drilling, a weight of 9 lbs/gal is desirable. The pressure in mud column at the bottom of hole, is the direct function of mud density. This pressure must be adequate at all times to prevent the flow of formation fluids into mud column. On the other hand, it is not economical to make mud weight too high because excessive mud weight results in breaking weaker formations, as a consequence of loss of circulation.

VISCOSITY

It is the cohesive resistance for the adjacent layers of liquid.

This is a measure of internal resistance to flow. The greater the resistance, the higher the viscosity. The resistance to deformation, exhibited by real fluid, is called its consistency.

$$\text{Viscosity} = \frac{\text{Shear stress}}{\text{Shear rate}}$$

The unit of viscosity is centipoise (CP). It is one hundredth of poise and it gives comparison with similar substance, water. The viscosity is determined by a Marsh funnel.

Specification of Marsh Funnel

Length of funnel = 300 mm

Diameter of top circle = 150 mm

Wire screen to be set 19 mm from top end, to conical end funnel of a piece of copper tube, is soldered, having length of 50 mm and internal diameter of 4.7 mm (Fig. 4.2).

The mud sample is poured through the wire screen until fluid touches the bottom of the wire screen. During this operation, the orifice tip is kept closed. This is done by holding the funnel in left hand, with index finger over the outlet. In order to reduce errors due to Thixotrophy (gelling of mud), the mud sample is taken from mud stream. The funnel is filled quickly and test made with little delay as possible. After the sample has been placed in the funnel and is prepared for the test, the fluid is allowed to run into calibrated receiver. A stop watch is started instantly when the fluid starts flowing from the funnel and is stopped when a litre (1000 cc) fluid has passed into a receiving cup. This is known as Marsh Funnel Viscometer.

50 mm tubing should be kept clean, otherwise viscosity figures will be unreliable.

The funnel can be checked for its correctness by filling it with water instead of mud. The time for outflow of 1 litre is (28+50) seconds. If the time of flow is higher or lower, it should be checked for errors.

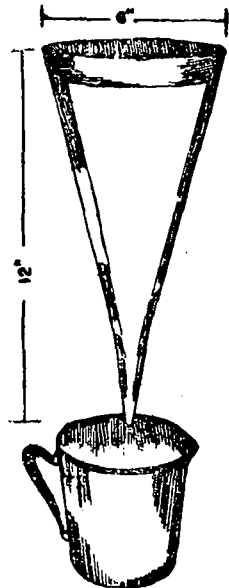

Fig. 4.2. Marsh Funnel

A good drilling mud 9 lbs/gls should flow through Marsh funnel in 35 to 45 seconds. When mud weight is 10 lb/gl, the Marsh funnel reading would come to 35 seconds or less. If it picks up native clay, the Marsh funnel reading would come to 43 seconds.

SAND CONTENT

Sand content is measured by volume and referred by volume. A given volume of fluid say 100 cc is washed on 200 mesh. Since washing is done with clean water, care is taken to only wash mud. The volume of sand caught in mesh indicated by graduation, on tube, are expressed as percentage of the volume of mud sample. Mud which carries less than 5 per cent of sand is acceptable. This is to prevent abrasion of pump and drill pipe.

GEL OR SHEAR STRENGTH

It is the measure of minimum shear stress to produce slip-wise movement. It is measured by Marsh funnel. The viscosity time in seconds is first determined with minimum delay between filling the funnel and making the measurement.

The funnel is refilled with mud and allowed to stand for 10 minutes after which viscosity is again measured. The time difference between the two fillings gives the gel strength in seconds. This is known as 10 minutes gel strength.

Secondly, it is measured by viscometer and the dial reading gives the gel strength directly in pounds per 100 sq ft.

MEASUREMENT OF FILTRATION PROPERTIES (WALL BUILDING TEST)

It furnishes the index of the ability of the fluid to form low permeable filter cake, on the walls of borehole and minimum of filtrate loss to the formation. The lower the permeability, the thinner the cake and lower the volume of filtration from muds with comparable solid concentration.

Low permeability of filter cakes are directly dependent upon the amount and physical conditions of the colloids in the mud.

- 1) Thin filtrate enable the easy passage of tool in hole.
- 2) Minimises the swabbing tendency, when pulling the drill string.

- 3) It gives better casing/cementing job.
- 4) Minimum filtrate loss, gives less hydration of shales and less caving.
- 5) Minimises the water blocking and hydration of clays.

HYDROGEN-ION CONCENTRATION

It is a guide to chemical treatment. Certain pH range is to be maintained for proper functioning.

The pH of a solution is defined technically as the negative logarithm of its hydrogen-ion in holes per litre concentration. We take pure water *pH-7 as neutral*.

pH-7 Neutral

pH > 7 Alkali

pH < 7pH (1-7) Acidic

If the mud is more acidic, mud pump parts will be corroded.

The addition of alkali as sodium hydroxide will increase the pH whereas the addition of acid will reduce the pH.

The test paper is impregnated with dyes of such nature that the colour is dependent on the pH of the medium in which it is placed. A standard colour chart is provided for comparison. We can know whether the mud is acidic or alkali. It is better to keep the mud between the pH 8-8.5 by adding soda ash (Na_2CO_3). Clear water is best drilling fluid. But this only serves the best purpose when the formations encountered are rocks having low permeabilities which do not slough or cave in the well.

Some of these formations, may have higher pressures, than the hydrostatic pressure in the bore hole, forcing the water out of the hole, or in case it has lower pressures than the hydrostatic pressures, the water being pumped into the hole would result in loss of circulation.

In the latter case, it would become extremely impossible to carry out drilling operations due to the formation of thick filter cake or alternatively result in sticking up of rods.

Water base mud consists of the following basic structure:

- 1) Liquid phase—water —continuous phase.
- 2) Colloidal phase—clays —dispersed gel forming phase.
- 3) Inert phase (barite SG 4.3)—Weighting material, fine silica quartz fine sand to control properties within.
- 4) Chemical phase ions, influence and control the behavi-

our of clays. On long research and development, it was established that bentonite (sodium bentonite) was the only material which could give colloidal suspensions. Sometimes the native clays or shale, may meet the colloidal requirement while drilling and it may be kept thinned with water. Otherwise colloids are purchased and added and for this proper finely ground bentonite, is the ideal one. Bentonite is rock deposit and the clay mineral in the rock, is montmorrillonite.

List of Equipment Used for Mud Testing

- 1) Physical Balance with range 1 to 5 kg.
- 2) Measuring Cylinder (100 cc) for measuring SG-gravity.

$$SG = \frac{\text{Wt. of mud} + \text{Cylinder}}{\text{Wt. of water} + \text{Cylinder}}$$

- 3) Two calibrated mugs 500 cc and 1 litre each.
- 4) Specific Gravity Bottle.
- 5) pH Paper Book 8-10 (book pH 6.5-9.5)—German
- 6) One Marsh Funnel. It is used to check viscosity of water, mud, gel value and ten minutes gel value.

Table 4.2. Viscosity Check

Quantity of mud taken (cc)	Quantity of fluid water/ mud passed (cc)	Time taken for fluid to pass (secs)	Inference
750	500	16	Water
750	500	25	Mud
750	500	30	Gel value

It is to be stopped for 10 minutes and then gel value is found out in the time elapsed in getting 250 cc.

7) Chemicals Soda ash (Na_2CO_3). Ratio 1:2; Sodium Hexametaphosphate (dispersing agent); Cutch-Caustic Soda agent (dispersing); CMC (for building textile industry); and Caustic Soda.

8) Apparatus for filter cake for water loss.

Commonly used chemicals for treatment of mud fluids are as follows:

1) Soda ash (Na_2CO_3) is a white coloured powder. It is not soluble in cold water but with rising temperature its solubility improves. It is largely used for combining ions of calcium and

magnesium that get into mud fluid. Together with drilled out material it is used to improve the wetability of clay during preparation of mud and the water loss.

2) *Sodium hexametaphosphate* serves in main to build the calcium and magnesium ions and to improve the wetability of clay at temperature up to 100 to 120°F, funnel viscosity and get strength of fresh water muds. Its effect is of short duration.

3) *Caustic soda (NaOH)* is colourless mass readily soluble in water. It is used for preparation of alkaline agents and also for raising the pH of the drilling fluid.

4) *CMC* processes lubricating properties. It is intended to reduce the coefficient of friction, wearing out of the drill pipes and to minimise the chances of the sticking of string to borehole walls.

5) *Cutch* is used in conjunction with caustic soda as dispersing agent.

METHODS OF DRILLING

Percussion Drilling

Percussion drilling is also known as Cable Tool Drilling. The hole is constructed by striking and the cutting action of drill bit which is alternately raised and lowered. The unit is skid mounted or powered with truck on which it is fitted. The rig is of portable type, power-operated and works on spudding principle exclusively (Fig. 4.3).

It consists of the following:

- 1) *Mast*.
- 2) *Hoists*: Two or three line hoists: one line for (Bull/drilling reel); second for sand-line; third for casing-line.
- 3) *Diesel engine* for powering these operations. The mast is made long enough to allow the longest string of tools/pipes to be hoisted from the hole.
- 4) *Drill frame* is of electrically welded steel and of rugged construction. Diesel engine/Gasoline engine, LPG and natural gas power is transmitted from the engine to the counter-shaft by V-belt.
- 5) *Spudder* used for raising and lowering of tools. Spudding gear is in the centre of frame and is supported by two bearings mounted on the centre of I beam. The assembly consists of two

forged crank arms, driving two forged pitmans which in turn operate two spudder arms.

6) *Bull reel*: Size of the bull reel line is $\frac{3}{4}$ in. (19 mm). It hoists and lowers the drill tools into the well. It is driven by

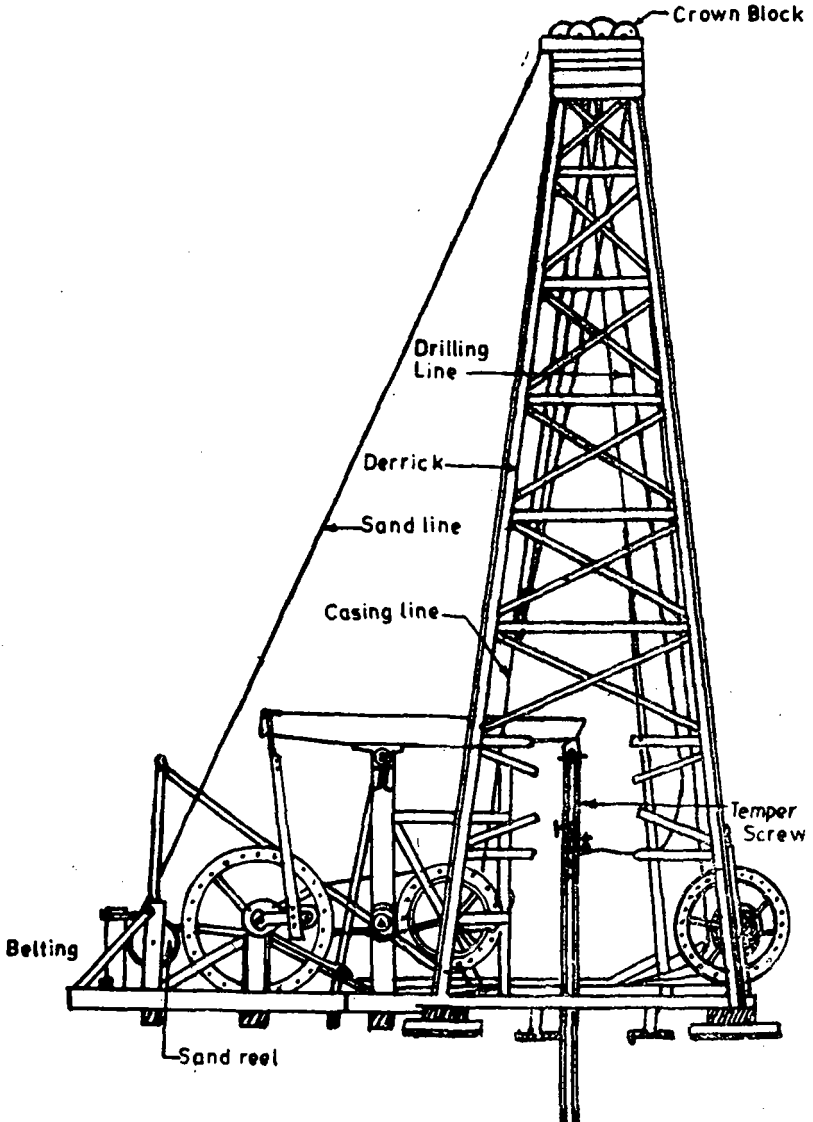

Fig. 4.3. Heavy Duty Standard Drilling Rig

roller chain and is engaged by a clutch mounted on the counter shaft. Bull reel has a divider which separates the working and the storage side from the drilling drum.

7) *Casing reel*: The casing reel is for handling the casing pipes. Size of the casing line is 5/8 in. (15 mm).

8) *Sand reel*: It is to hoist and lower the bailor which removes the cuttings from the well. Sand line size is 3/8 in. (9.52 mm). It has friction clutch and is mounted on antifriction bearing.

9) *Mast*: It has telescopic steel, mast of height 36 to 60 ft. (11 to 18.29 metres) and handles working load of 15,000 lb to 45,000 lb (6804 kg to 20412 kg). The height is so designed that rated capacity of the drilling tool is achieved by using the longest stroke of the spudder. Heavier weights can be handled using shorter strokes.

10) *Pitman*: Pitman arms connect the end of the spudding beam to the crank. The spudding beam imparts the up and down drilling motion to the drill tool.

11) *Derrick head shock absorber*: Derrick head shock absorber consists of rubber discs, located beneath the crown sheave. Each disc consists of two concentric rubber rings permanently bonded to a steel plate. As the tool string drops its drilling motion, it squeezes the rubber discs together. On hitting the tool to the bottom tension is removed from the discs. They expand to provide snap-action to pull the tool off the ground as the motion of the spudding arms brings them back up for the next drilling stroke.

12) *Counter-shaft*: It is mounted on precision type roller bearings and is provided with disc type clutches for driving the bull reel, casing reel and spudder.

13) *Cathead*: They are reels located at the working end of machine, and are clutch driven from the counter-shaft. They are used for pulling heavy material and also for screwing and unscrewing the pipes, etc.

14) *The drill string* (Fig. 4.4): It consists of rope socket with rope saver; drilling stem; set of drilling jar collars; and drilling bit.

The drilling jar is a safety device to loosen the stuck tool by jarring them and has no drilling function. The drilling stem provides the bulk of weight necessary for drilling and also works as

guide for the tools, working up and down in the hole. The total weight of the selected tool should be less than the maximum

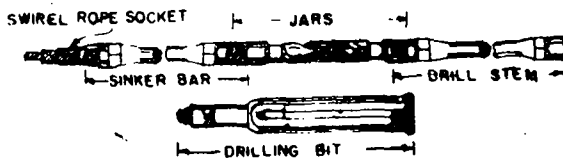

Fig. 4.4. Tool String with Bit

weight handling capacity of the machine for smooth operation. Operating with tool weight which the machine can lift smoothly and drop rapidly, with clean sharp blows, results in better performance.

Another important point which governs the selection of the tool is the joint size which is related to the size of the hole to be drilled. It is desirable to use larger tool joints for providing enough tool weight instead of using longer drilling stems for the purpose. The length of drilling stem should not exceed half the height of the mast. The joint size determines the size of other tools.

All these have box-pin joints API, tightened with a set of special wrenches, fitting on their squared sections, through attached slip circle. Check mark is given on them to guard against any slippage, during the operation. The string is attached to swivel socket through babbitt metal connections with mandrel. The rope saver is used at the top of rope socket, to guard against any kinks that may develop, in the drilling line.

This type of wire rope socket, has the advantage that it never allows the cutting edge of the bit to give one blow at the same place, thus eliminating the drilling of a crooked flat hole. However, the wire rope at the top of the socket should be repeatedly checked against accident that may develop with broken strands of wire.

Sinker jar: It is used above the jars, to increase the hammer blows at the bottom of hole.

Drilling jars collar: They consist of two connecting links with a pin on the upper link and a box on lower end. They are to prevent the string to be stuck up. The jars have stroke of 5 in. (12.70 cm), 9 in. (22.8 cm). They are to be inspected regu-

larly for replacement due to wear and tear (Fig. 4.5).

Drill stem: The drill stem gives the weight to the drill string. The stem is always below the jar. These are 8 ft. (2.43 m) to 16 ft. (4.87 m) in length. These are in size 4 to 4½ in. (100-112 mm) and should be handled safely while loading and unloading.

Pipe driving equipment: Drive equipment consists of a drive shoe at the end of the casing and a drive head fixed at the top. The stem of the tool is used as a hammer. A drive clamp is fixed on the stem through the drive head at the top of the casing as the tool goes up and down. The stem serves as guide through the head furnishes part of the weight required for driving.

Casing elevators: These are used to raise or lower string of pipe casing. Slip-spider casing ring is used to hold the casing at the well opening, while raising or lowering long strings of pipe with an elevator.

Drilling bits: The size of the drilling bit is determined by the diameter of the hole to be drilled. The length of the bit may be varied according to the weight capacity of the drilling machine (Fig. 4.6).

a) *Regular pattern bit:* It is a figure of eight sections. It is the common type used with reasonable success almost in all formations. The regular type of bit has size 16-6 in. (400-150 mm) and forms an important part of the tool string. It is important to check up the diameter of bit with bit gauge against the wear and tear. The bit needs regular dressing while drilling compact formations. It has to penetrate crush ream and mix the formation. It resembles a blunt chisel. The bit has grooved sides known as water courses which help in the removal and penetration of boulders (4.6 A).

b) *California pattern bit:* It has long sloping shoulders. It is used in drilling large holes in hard formation and where the drill-

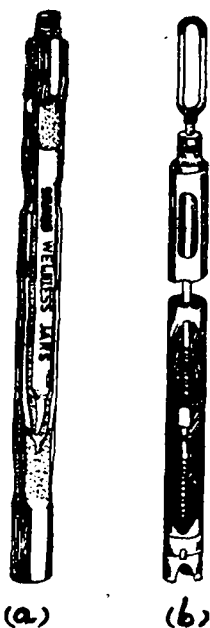

Fig. 4.5. Drill Jar and Sand Pump

ling is carried on ahead of casing (4.6 B).

c) *Star or four wing bit*: It is used for straightening crooked holes and drilling in fissured formations which tend to reflect a regular pattern bit (4.6 C).

d) If spudding bit is short and thin. It is used in drilling holes in soft formations (4.6 D).

e) *Eccentric offset bit*: It is used to enlarge the hole to permit the casing to pass. The eccentric bit cuts below the casing shoe, allowing the pipe to be driven through the formation. There are many other type of bits for reaming, under cutting or for

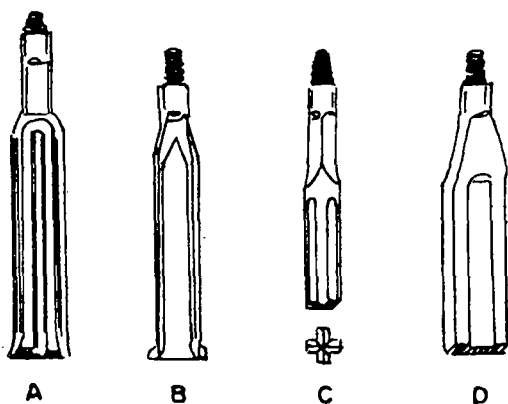

Fig. 4.6. Drilling Bits

straightening a hole. Use of any particular bit is largely determined by the local formations and experience of the driller.

f) *Bailers and sand pump*: A bailer/sand pump (Fig. 4.5b) is used for removing the drill cutting from time to time. A bailer consists of pipes of section 8 to 20 ft. with a valve at the bottom and hook at the top for attaching the cable. The diameter of the bailer is determined by the size of the hole to be drilled. There should be enough clearance so that the bailer falls freely. Bailers are equipped with steel flap having steel-cum-rubber valves or dart valves. When the bailer reaches the bottom the valve is opened and material is sucked in. On pulling out the bailer the valve is closed and drill cuttings are brought to the surface. This is to be emptied from the top by tipping the bailer. The bailer with dart valve is emptied by striking the bailer on the solid ground which allow its tongue to open and the

material is emptied out. The bailer is used for rapid bailing of the drilled cuttings which mix well with water during drilling and are kept in suspension. Sand pump is similar to a bailer except it is equipped with a piston for the purpose of drawing the drill cuttings into the well. Sand pump is used for removal of heavy drill cutting. It is more effective than flap valve bailer.

PRINCIPLES OF OPERATION

The successful cable tool drilling is dependent upon imparting satisfactory drilling motion to the drilling tools. The tool weight is supported by the cable. The blows are delivered, in rapid succession and with the smoothest action when the cable is under tension with the striking of the bit on the formation.

The upward lift of the tool must be slow so that the cable can lift the tools safely throughout its length. It is indicative by the vibration wave at the top. The downward stroke is divided into two steps. In the first step, the tools and cable fall freely and in the second step, the tools are decelerated and the cable is stretched to proper tension, corresponding to the impact on the bottom of hole at that movement. The total length of the stroke is then governed by two factors, the stretch necessary to produce the required tension in the cable and the required free fall distance. The repetition of the operation continues over a long period till the desired hole is completed. The performance of the bit depends besides the other factors, on the kinetic energy it delivers when striking the bottom of the hole.

Wells drilled by cable tool tend to deviate slightly from the vertical. Therefore, the action of the cable, is dampened by the frictional contact with the wall of the hole. No fluids are circulated and we can get uncontaminated samples without being mixed with mud. The operations are intermittent in nature, and hence slower in penetration. The investment cost and operating cost are lower. The penetration rates are much affected and the drilling rates are slowed down.

The general drilling procedure consists of drilling of hole, withdrawal of the drilling tools and then removal of the drilled rock material with actual drilling. The total amount of hoisting is dependent on the depth of the hole. The hole must be filled with water all the while to control the heaving. The hole is

usually started with 24 in. (600 mm) bit and then 22 in. (558 mm) casing with cutting shoe is lowered till it could go. Then the hole is telescoped as the drilling proceeds with the lowering of 20, 18, 16 and 12 in. (508, 457, 406 and 300 mm) casing with cutting shoe. This is continued till the penetration rates slows down again. The 6 in. (150 mm)/8 in. (203 mm) assembly is lowered with bail hook at the bottom. The annulus between

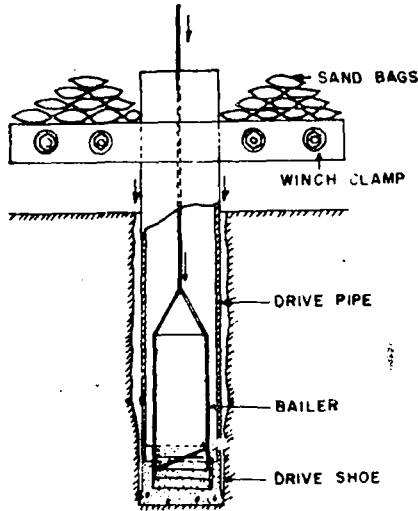

Fig. 4.7. Loading Clamp

6 in. (152 mm)/8 in. (203 mm) and 12 in. (300 mm)/16 in. (400 mm) are gravel-packed side by side while the removal of the casing is done without allowing any gap in gravel pack otherwise the infiltration of sand would creep in and the well screen may be filled up. Sometimes the sinking of casing is facilitated by putting extra weight through welded nipple and clamps on the top of casing so that it could sink as the cuttings from inside are removed from the hole or the bit is run inside the same (Fig. 4.7).

The wench loading system is also employed for forcing the casing. Sometime Anchor bolt system is also resorted to in hard clays etc. (Fig. 4.8).

Fishing tools: Fishing tools for percussion drilling have been described in the chapter on Fishing Tools, and Practices.

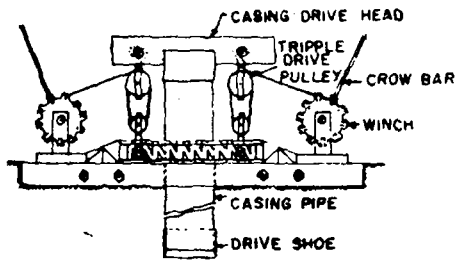

Fig. 4.8. Loading Winch

SPECIAL PRECAUTIONS TO BE OBSERVED

- 1) The length of the open hole should not exceed the total length of the drill string under any circumstances.
- 2) Small pits should be dug around the casing and should be filled with bentonite (1 lb of bentonite in 6 gls of water), so that it act as lubricant for easy removal of casing.
- 3) To avoid freezing of casing, use of dispersing agent is must so that sticky clays are dissolved and dispersed evenly. This would give movement to the casing during drilling and extraction.

Direct Rotary Drilling

In Rotary Rig (Fig. 4.9), the hole is drilled by rotating the drilling string and bit to which downward force is applied. The bit is tightened to the lower most end of kelly, drill collar though substitute and rotated by a drill string, composed of high quality steel drill pipes and drill collars. New connection of drill pipe of length approximately 6 metres are added as the drilling progresses. The rotary motion is imparted by a rotary table, having bevel gears and pinions. The speed of rotation is controlled according to the type, size of bit and formation. When the bit required to be changed, it is raised to the surface by unscrewing the joints and lowering them again. During the drilling operations, mud (drilling fluid) is kept constantly flowing downward inside the drill pipes, out through the water courses—in the bit and upward through the side of drill pipe and annulus of the hole. This mud serves the double purpose of keeping the bit cool and supporting the walls of the hole by virtue of the hydrostatic pressure, exerted by it. By this

means, in many cases, loose materials may be prevented from caving and when water bearing formations are penetrated. The

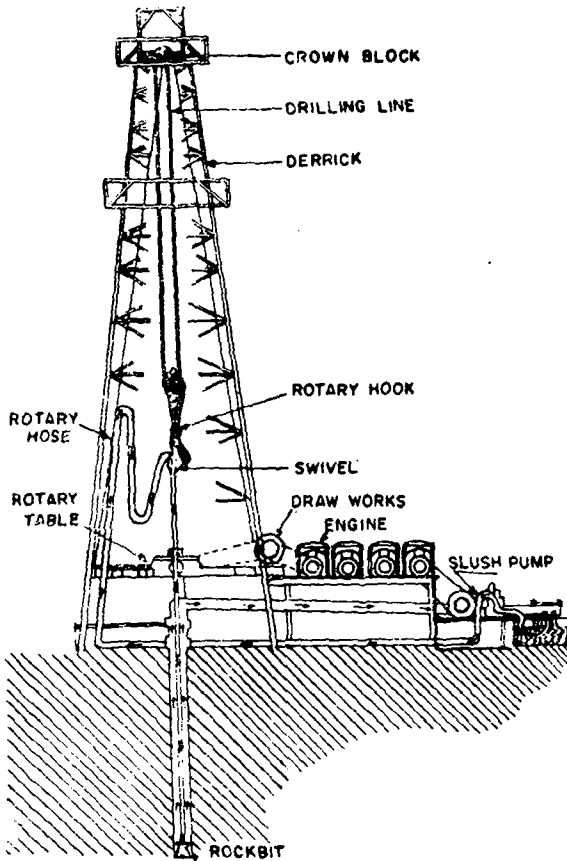

Fig. 4.9. Rotary Drilling Rig

drill cuttings are also lifted from the hole to the surface, by fluid being pumped at sufficient pressures with the help of mud pump. The return velocity is 120-180 ft./min [6 mt./sec. to 9 mt./sec.]

At the surface, the returning fluid (mud) is diverted through two pits size $10' \times 10' \times 3'$ ($3 \text{ m} \times 3 \text{ m} \times .9 \text{ m}$) and settling pits 2 Nos. ($1' \times 1' \times 1'$) ($.3 \text{ m} \times .3 \text{ m} \times .3 \text{ m}$) to allow cuttings to settle and separate. In the last of these pits, fluid is again picked up by the pump suction, which repeats the cycle. Rotary drilling

equipment is of complex nature. Hence following basic components of machine be considered.

1) *Mounting*: The drill can be truck trailer mounted or skid mounted depending upon terrain and requirement of job.

2) *Power unit*: This is the prime mover for the component of a drill rig. The size will vary according to the work to be done. Usually Diesel Engines of horse power range of 75 to 150 h.p. are used.

3) *Chain case*: Power is transmitted from the engine by a multistrand roller chain running over sprockets and shafts. Power is transmitted to winch, rotary table, pulldown mud pump and other components.

4) *Rotary table*: Rotary Table has two primary functions. (1) it transmits the rotation to the drill string by turning the kelly-joint, and (2) it suspends the pipe weight during connection.

The top of rotary table forms a portion of derrick and is provided with non-skid thread. It is usually made up of alloy steel fitted with anti-friction bearings, ring gear, sealed in oil bath etc. These are capable of supporting the dead load of the drill string or casing. It should be properly locked to check against any upward movement. Suitable guards are arranged so that water or contamination can not enter the oil bath. The ring gear of its drive pinion are of design other than the straight bevel gears to afford smooth operation. Power is taken from main draw-works and transmitted to rotary table, through chain and sprockets. The drive rotates the horizontal pinion shaft, the spiral bevel gear rotates the ring gear, which in turn rotates the vertical drill string. Rotation speeds are controlled at the driller station.

5) *Break-out tongs*: They are used to loosen joints in the tool string. They are manually positioned over the rotary table and clamped around a kelly to keep these parts from turning while the rotary table turns the other section of drill string.

6) *Pulldown equipment*: It is used to put load to the bit for forcing it down into the formation to be drilled. This employs variable speed mechanism, generally hydraulic so that pulldown pressure can be varied from 0 lb to 30,000 lbs (13,608 kg.).

7) *Draw works*: It is the key piece of equipment on a rotary rig. It is the controlling centre from which driller operates the

rig. It contains hoisting and rotary clutches, chains, sprockets, engine throttles, brakes and other controls which enable the rig to be operated. It has the drums which spool the drilling line, hoisting line, sand line for feed of operation. Usually 4 speed gears (30-150 rpm) are exclusively used due to simplicity and easy maintenance. It is governed by the horse power and the depth rating.

8) *Cat head*: It will lift light loads if the rope is wrapped around the load, while the cat head is turning. They can be used on larger machines to help break pipe strings.

9) *Derrick mast*: It supports the rotating mechanism of drill pipe and handling equipment. The function of mast/derrick is to provide vertical clearance for the raising and lowering of drill string, in and out of the hole, during drilling operations. It must be of sufficient height and strength for working efficiently. The mast is of tubular structure, cold drawn seamless steel electrically welded material which has a crown block containing sheaves over which hoisting lines and sand lines travel, mounted on it. The normal capacity of water well rigs is from 1500 to 2500 ft. (457 to 762 m). As such mast is from 40 ft. to 60 ft. (12 to 18 m) in height. These days, portable derricks are used and of telescoping type for lowering and raising mast. Usually these are hydraulically operated, through hydraulic pump, having a set of valves.

FLUID CIRCULATING SYSTEM

Mud pumps are double acting piston type—each rotary rig is equipped with suitable mud pump. The transmission line pass the fluid through the drilling device to the bottom of the hole from which it carries the cutting to the surface.

The function of mud pump is to circulate the drilling fluid powered with 16-122 h.p. and of 52-487 gls/min displacement (3.94 litre/sec to 36.52 litre/sec).

The pump normally used for above services are having two cylinder (duplex), double acting reciprocating type. The term double acting, denotes that each side of piston, does the work while duplex refers to numbers of pistons (two). The superiority of the piston type pump for drilling service is largely due to the following features:

1) Ability to handle and circulate fluids, containing high

percentage of solids, many of which are abrasive.

2) Valve clearance will allow passages of large solid particles from cuttings without damage.

3) It has simplicity in operation and maintenance. Liners pistons and valves may be replaced in field by the rig crew, as and when needed, depending on the depth of bore hole conditions.

4) The volume of fluid determines the largest diameter of hole that can be drilled by using different lines and piston sizes. As depth increases the size of the liner is reduced to provide adequate pressure.

5) Promote drilling through jetting action in the bit. Mud pumps are commonly denoted by bore and stroke 6×8 in. (152×203 mm) power pump has a piston diameter (liner size) of 6 in. (152 mm) and stroke length of 8 in. (203 mm). Usually size employed is 5×8 in. ($125 \text{ mm} \times 203 \text{ mm}$) in ground water drilling up to 1500 ft. depth (450 m). It is powered by h.p. of 85-100 @ 1500-1800 rpm.

The main defect of these pumps is that these give pulsating discharge, making periodic impact on discharge lines. The maximum permissible plunger rod load together with pumping pressure governs the liner diameter as the product of piston area and pump pressure must not exceed the maximum load.

Table 4.3. Gardner Denver Mud Pump Details

Rig No.	Model	Size of liner	Pressure Lb./Sq."	Discharge G.P.M.	R.P.M.
Frank Rig	FY-FXX	7-1/2" (190 mm)	182	378	63
	7-1/2" \times 8" (190 mm \times 203 mm)	5" (127 mm)	409	164	
Wabco	FXFXD	7-1/2" (190 mm)			
	7-1/2"-10"	7" (177 mm)	255	427	57
	(190 mm \times 254 mm)	5" (127 mm)	574	185	57

DRILL STRING

Consists of the following:

Drill pipe is the pipe to which the drill bit is connected. It is made in many sizes and lengths with various type of joints. With a given size of drill pipe (6 m generally) it is usually possible to use the largest size bit permissible for the next higher

size drill pipe for enlarging the hole by reaming. In this way, it is possible to enlarge $12\frac{1}{4}$ in. (31 cm) hole by reaming in several stages if necessary to $18\frac{1}{2}$ in. (47 cm) with $2\frac{3}{8}$ in. (73 mm) drill pipe. The drilling and reaming method of drilling large hole makes it easier to drill a straight hole and is faster and more economical than drilling larger hole in one operation.

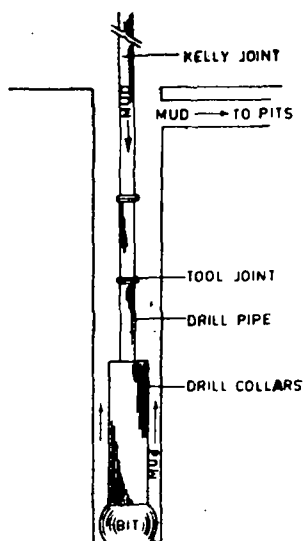

Fig. 4.10. Drill String Components and Bit

The drill pipe have internal upset or external forged on each end of tube. The purpose of this upset is to give additional wall thickness and strength to the end of pipe in which the threads are machined. External upset drill pipe are generally made in 4 in. and in the smaller sizes. The internal upset is adopted for $4\frac{1}{2}$ in. (114 mm) and larger sizes. The drill pipe size is governed by the bit size to be used. Normally the following sizes of bits are used with different sizes of drill pipes (Fig. 4.10).

Table 4.4. Bit and Drill Pipe Sizes

O.D. pipe	Drill pipe		Drill bit			
	Type	Joint	O.D. of tool	Joint cm	Smallest	Largest
$2\frac{3}{8}$ " (6.03 cm)	API	IF	$3\frac{3}{8}$ " (85.725 mm)	8.57	$3\frac{7}{8}$ " (9.84 cm)	8" (203 cm)
$2\frac{7}{8}$ " (7.30 cm)	API	IF	$4\frac{1}{8}$ " (104.7 mm)	10.48	$5\frac{1}{8}$ " (13.02 cm)	$12\frac{1}{4}$ " (31.12 cm)
$3\frac{1}{2}$ " (8.89 cm)	API	Reg	$4\frac{1}{4}$ " (127.9 mm)	10.7	$5\frac{5}{8}$ " (14.29 cm)	$18\frac{1}{2}$ " (46.99 cm)
$4\frac{1}{2}$ " (11.43 cm)	API	Reg	$5\frac{1}{4}$ " (139.7 mm)	13.93	$6\frac{1}{2}$ " (17.15 cm)	26" (66.04 cm)

Selection of the smallest permissible bit with given size of drill pipe is governed by the necessity of having an annular area between the O.D. of the tool joint and the wall of the hole sufficient to handle the upward movement of the drilling fluid and

the drill cuttings it carries, therefore the smallest permissible bit is an absolute specification. The largest permissible bit with given size drill pipe is governed by its capacity to transmit the required torque which will be affected by depth, weight on the bit, speed of rotation and type of formation.

It has to be ensured that the total weight of the drill string does not exceed the lifting weight capacity of the drill machine. The adjustment could be made by altering the size of the drill pipe and the number of collars put in.

DRILL COLLAR

The drill collar forms the part of the drill stem consisting of three parts:

- a) One or more drill collar just above the bit.
- b) One or more length of drill pipe.
- c) Kelly.

The drill collar actually is heavy walled joint of the drill pipe, used just above the bit in the drill string. The extra weight keeps the drill pipe in tension, which assures maximum resistance to fatigue and helps to stabilise the bit and keep the hole uniform and straight. Drill collar outside diameter is larger than that of the drill pipe but small enough to clear the wall of the hole. The remaining annular space must provide enough room for overshot fishing tool to be lowered in case of collar twist off.

SUBSTITUTE JOINT

It is an adaptor to connect two components when their threads do not match. It could be box to box, pin to box, pin to pin.

BITS

There are number of rotary bit designs available from a number of manufacturers, i.e., Hughes, Reeds, Russian, Hungarian. All of these are made to give best performance in various types of formations. The bits are classified into five general types : (a) Drag Type, (b) Rock Roller Bits, (c) Jet Bits, (d) Diamond Bits, and (e) Carbide Button Bits.

a) *Drag bits* 6-3/4" (171 mm), 9-7/8" (250 mm), 11-3/4" (298 mm), 13-3/4" (349 mm), 18" (457 mm): Drag bits have no

moving parts and drill by the shovelling action of their blades (three-way and six-way) on the formation. Their water courses are placed such that the drilling fluid is directed on blades, keeping them clean. Bits of these types are widely used for drilling in soft formations. The blades are made from alloy steel and are normally hard-faced with tungsten carbide. These are meant for clay and shale formations. The drag bits have short blades and wings which are forged and dressed to form the thin cutting edges which are hard faced and have tungsten inserts on the outside corners. The body of the bit is hollow with holes drilled on each side to direct the drill mud near the centre of each cutting edge according to the number of blades. The drag bit may be divided into two-way bit or fishtail, a three-way bit and six-way bit also called pilot bit. Drag bits have shearing and scraping action and are suitable for drilling only in loose sand and soft clay. Better balance drilling is done with six-way and three-way bit than with the fishtail bit. The performance of six-way bit is better than other bits. They are unsuitable in drilling in hard rock. In drilling shattered and boulder formation, the drag bit are dulled rapidly and defect the hole, thus imposing irregular torsional strain and vibration on the drill rods.

b) *Cone type rock roller bits* 5-5/8" (142.8 mm), 6-3/8" (160 mm), 7-7/8" (174 mm), 9-7/8" (250 mm), 11-3/4" (298 mm), 13-3/4" (349 mm) 16" (406 mm), 18-1/2" (469 mm), 20" (508 mm) (Fig. 4.11). These have three cones, as forged steel body and a cone axle or pin which forms a part of body. These cones have roller bearings fitted at the time of assembly. The cones are not removable. The three cone construction provides smooth operation. The shape of the cutting surface and the design of teeth is of different design to suit different formations. Some have inter fitting or self cleaning teeth. All cutting surfaces are flushed by the circulating fluid. For soft formation the bits have long widely spaced teeth. For hard formation, short teeth, less spaced and less cone-off-set. The cones of these bits are off set i.e. the axis do not intersect at common point.

Rock roller bits are more generally used for their structural strength and balanced cutting action. Cross roller rocks bits are used in formation where the hole has tendency to become crooked. They are also used for straightening such holes when drilling with cross roller bits, lighter weights are used as these

bits lack the structural strength of the cone bit.

According to the passage of water courses the rock bits may be divided into regular bit and jet bit. The nozzles in the regular bits are positioned to direct the drilling fluid into the cutters, thus using the main force of the fluid to keep the cutters clean. A portion of the energy is used to clean the cuttings.



Fig. 4.11. Three Cone Rock Roller Bit for Soft Formations with Conventional Mud Discharge Ports

c) *Jet bits*: The nozzles of the jet bits are also so positioned that jet stream directly impinges the hole bottom and miss the cutter entirely. The cutters are cleaned by the turbulence created around the bit. Jet bits are used only with adequately powered high capacity mud pumps. They drill faster than regular bits.

Jet bits are roller cutter bits, which have been provided with fluid nozzles, each directs a high velocity fluid jet directly on the hole bottom, which rapidly removes cuttings. They require pumps of higher capacity, every time new formation is penetrated.

d) *Diamond bits* (4-3/4" (110 mm), 6-3/4" (171 mm): Drilling is done by grinding action of diamond stones which protrude from steel matrix. These bits are used in very hard and compact formation, especially for core drilling with barrel etc. These are very rarely used in water well drilling except when basement samples are needed (Fig. 4.12).

e) *Carbide button bit* is specifically used in hard abrasive formation as lime dolomite, granite and hard sandy shales one normally too hard for steel tooth bits. Sinistered tungsten and forged alloy steel is combined to provide abrasion resistance.

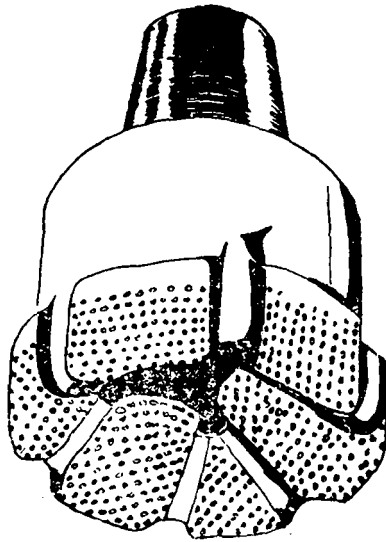

Fig. 4.12. Diamond Bit

TRAVELLING BLOCK

The mechanical leverage required to handle a casing string is gained through travelling block containing one or two sheaves, depending on the weight to be lifted. It can be double or triple type. The limiting factor is the capacity of mast.

ELEVATOR

It is a device to lift pipe or casing. The simplest is a hinged clamp or a ring with quick locking device to prevent it out from opening once clamped. The bails are attached to hoist. The bore is slightly more than the pipe so that it can slip up against the coupling or collar when pipe is suspended.

ACCESSORIES EQUIPMENT

Swivel—15 to 25 tons, top load guide assembly (Fig. 4.13): It is meant for conducting fluid into rotating drill pipe for suspending them in the well. A gooseneck and wash pipe is also provided. The ball bearings are lubricated by pressure grease guns. It performs the following functions.

- 1) Suspending kelly and drill string.
- 2) Free rotation of kelly and drill string.
- 3) Connection for the rotary hose and a passage way for flow of mud fluid into the top of kelly and drill string.

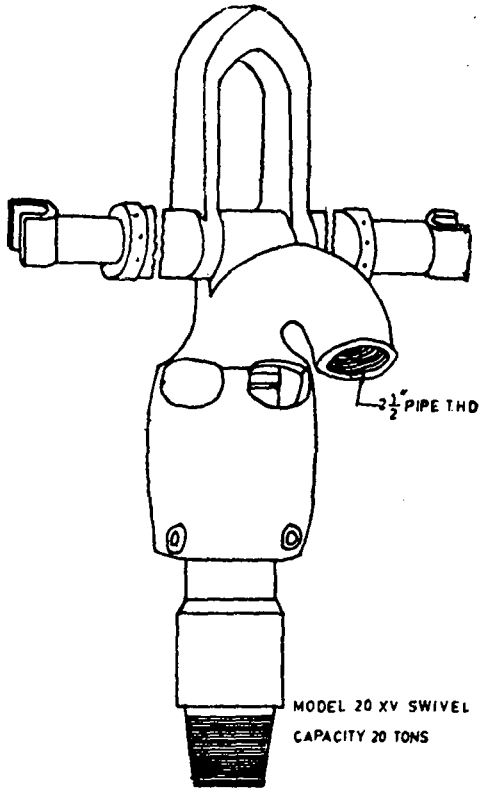

Fig. 4.13. Swivel Guide Assembly

The chief operating parts of swivel is tapered roller bearing (Higher capacity thrust bearing) design and rotating fluid seal (rubber or fibre) and metal ring, against the rotating member inside the housing. The fluid passage is 3 in. (75 mm) the lower end of the rotating member of swivel is provided with left hand threads API. Swivel are given in various load capacity. Deeper drills require heavy duty swivel and shallow drill lighter ones.

Kelly (Grief Stem) (4-1/2" × 28 ft square). (114 m × 8.5 metre) (Fig. 4.14): Kelly (grief stem) is the hollow section whose upper

end is suspended from the swivel, and lower end is joined to drill rods. It allows the circulating fluid to pass through the kelly into the top of the drill pipe. Its inside diameter is $2\frac{1}{2}$ in. (63 mm) and outside cross section is usually a square or hexagonal $4\frac{1}{2}$ in. (114 mm) or round sometimes. The purpose of which is, to transmit the torque from the rotary table to the drill string. Tool joint on the lower end of kelly, is right hand API (similar to the threads on drill pipe) and thread on top is left handed. During drilling operations, the kelly bushing remains on the kelly. The outside of kelly is usually having 16 in. square bushing. With its removal, 16 in. (400 mm) bit or casing can pass through rotary table. The kelly is free to slide with the bushing, so that the kelly be rotated, lowered and raised during the drilling operations. The threads on kelly can be recut and threaded after these are worn out.

Kelly drive bushing is a cylindrical piece with square driving head at the top end. The inner bore is slightly more than outside diameter of kelly. Drive keys fit into these flutes and into those in kelly they are held in place by a plate fastened to drive bushing.

Swivel hose 2 in. (5.08 mm) and 17 to 20 ft (5.2 to 6 m) with wire reinforcement to withstand abrasive fluid pressure.

Stand pipe hose: Same as above but 4 ft 1.22 m).

Suction hose: Connects the mud pump and slush pit 20 ft long (6.1 m) of size 4 or 5 in. (100 to 125 mm).

Mud mixing hose: Wire wrapped high pressure hose for mixing mud 1×25 ft (25 mm \times 7.5 m).

Operating fundamentals: There are three fundamental operations in rotary drilling: drilling the hole, removal of cuttings and setting of well casing.

Reamers, under reamers or hole openers 18" (457 mm), 20" (508 mm), 24" (608 mm) (Fig. 4.15): These roller type cutters are used to enlarge holes already drilled. Three removable cutters are fitted in the middle of a thick walled hollow steel



Fig. 4.14. Kelly

tube and at extreme lower end, a rock bit is screwed to guide the reamer. This would pilot the hole and enlarge it also. The reamers permit the use of greater weights on the bit and still maintains a straight hole. The under-reamers are used for enlarging the boreholes. These are worked through the casing for achieving bigger sized bore.

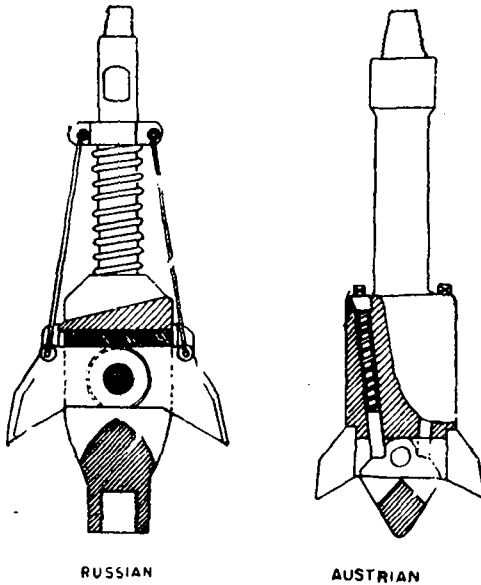

Fig. 4.15. Under Reamers

Slips are the gadget to hold drill pipes when a connection is made, each pair of slips is made for pipe of a certain diameter. The inside bore has teeth or threads which fit the outside of the pipe. The outside of slips is tapered to correspond with the taper on the ring.

The common practice is to use weight ranging from 1000 to 6000 lbs (454 to 2718 kg) per inch of the diameter of the bit with corresponding rotary speeds of 30-150 rpm for soft/medium formations and decreasing the same in harder formations. For hard and abrasive formations the bit pressure may be decreased and limited between 2000 to 4000 lbs (906 to 1812 kg) per inch diameter of the bit. The factors that influence the rate of drilling are the bit, the pressure on the bit, the speed of rotation and quality, volume and velocity of the drilling mud. They have to vary

according to the drilling conditions and nature of formation met with. Weight on bits improves penetration rate. However for best bit performance rotary speed is to be reduced as weight is increased.

Lost circulation occurs in porous formation when drilling fluid seeps into formations instead of coming in the return flow. These zones of lost circulation contain large supplies of water. In such cases, lost circulation be regained or percussion drilling may be done.

Lost circulation occurs in fissured formation such as quartz, sandstone, quartzite; in shale which is jointed and fissured. Satisfactory drilling progress is made in this formation by using a mud of high viscosity; sand and gravel can also be parts of lost circulation. The mud loss should be replaced with mud and not with water.

Lost circulation can be regained by mixing fibrous material with drilling fluid, i.e. cotton seed, bran, sawdust. Otherwise the hole may be abandoned. If circulation is lost in cavernous lime stone, the discharge is checked and tested for fresh water. If the quality and quantity is sufficient the hole can be completed in formation.

Average progress range is 100-150 ft. (30-45 m) in 8 hours shift when the hole is drilled, (free of cuttings), in semi-consolidated Alluvial formations.

Fishing Tools: These have been discussed in the chapter on Fishing Tools and Practices.

ADVANTAGES

1) Suitable for drilling deep hole in unconsolidated formations and for test drilling.

2) Exploration results can be obtained in shortest time and cost.

DISADVANTAGES

1) Unsuitable for boulder formations, hard rocks due to slow progress and high bit cost.

2) Unsuitable in fissured formation and zones of lost-circulation.

3) Mud drilling is harmful in low pressure formation due to mud invasion.

- 4) Requires large quantity of water which may have to be brought from long distances.
- 5) Accurate strata logs are not available.

REVERSE ROTARY METHOD

It is a variation of Direct Rotary Method and is very common in alluvium especially in the Indo-Gangetic Plains of India and Pakistan. It is capable of drilling wells up to 48 in. (1200 mm) in diameter up to the depth of 500 ft (150 metres). The method is chiefly a suction dredging method in which cuttings are removed and brought to surface by a rotating suction drill pipe. The drilling rig is similar to that for hydraulic

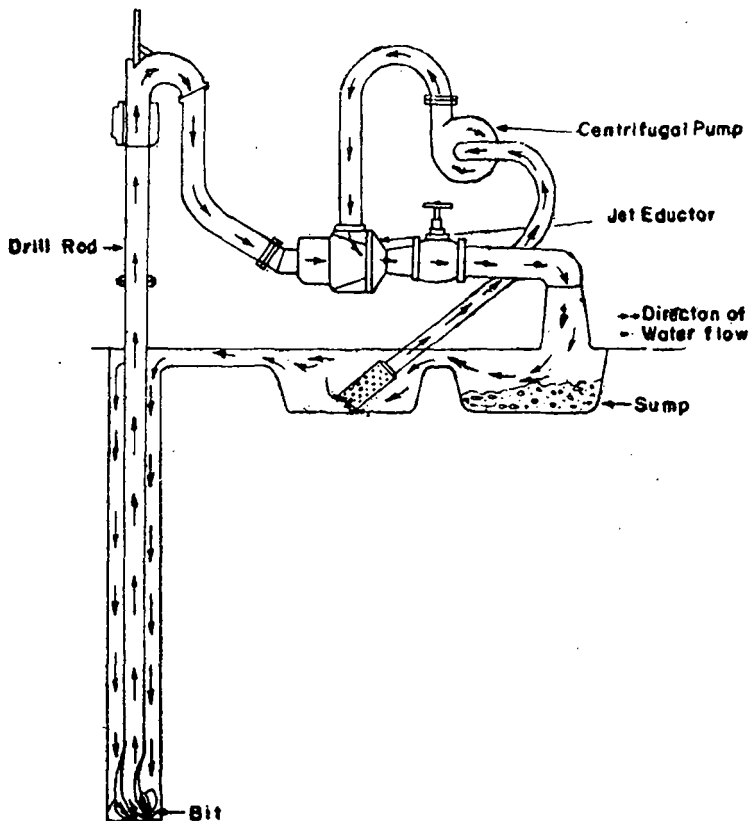

Fig. 4.16. Reverse Circulation

rotary method except that it includes a large capacity centrifugal pump, 6 in. (150 mm) diameter drill pipe and a bit, something like cutter head of a dredger (Fig. 4.16).

The walls of hole during drilling are supported by hydrostatic pressure, acting against a film of fine-grained materials deposited on the walls. The cuttings are removed or sucked by water and not by drilling mud, flowing up through the pipe. The mixture is circulated through a sump in which sand settles out but fine-grained particles are recirculated back into the hole, where they help in stabilising the wall. The water table should be several feet below to obtain an effective head differential between wall and aquifer.

Basic Rig Components

The reverse rotary drilling method is almost like Direct Rotary drilling except for the circulating system. The basic rig components are in following order.

- 1) Mast
- 2) Drawwork
- 3) Sand and Priming Pumps
- 4) Prime Movers
- 5) Drill String
- 6) Bits
- 7) Drilling Line and Miscellaneous Rig Equipment.

1) MAST

The function of mast are identical to the derrick of rotary drills, that is for lowering of drill string into and out of the hole, during drilling operations. This is made of tubular structure.

This is normally about 35 ft (11 m) from the ground. The mast should be sufficiently strong to take the load of drill string while lowering and pulling it out of the hole.

2) THE DRAWWORKS

This is the key piece of equipment on the rig. It is the control centre from which the driller controls the operations. It contains clutches, brakes and other controls. The controls are provided to work the drums for drilling line, sand line and casing line.

3) SAND AND PRIMING PUMPS

The function of the sand pump is to circulate water and to suck the cuttings from the hole. This pump is constructed to handle heavy abrasive materials. It is most simple piece of machinery and has only two moving parts, a shaft and an impeller attached to the end of shaft which revolves inside of a tight casing.

The impeller revolves at a speed sufficient to create pressure, high enough to force water and send through the discharge pipe line at a speed approximately 12 ft/sec (3.75 m/sec). As the water is discharged, partial vacuum is created in the central part of impeller and water is then forced into the impeller through suction pipe line by atmospheric pressure. As the atmospheric pressure is constant, the suction cannot be increased beyond a certain point.

A centrifugal sand pump operates on the principle of centrifugal water pump. Clean water should be pumped by small auxiliary pump, which will have capacity enough to develop some pressure near the working pressure of the main pump.

4) PRIME MOVERS

Prime movers of diesel type and adequate h.p. are provided.

5) DRILL STRING

Drill string is almost, identical to components used in direct rotary system but differently manufactured.

Kelly joint: Kelly joint is hollow square-bar with normal specification of 6 in. \times 6 in. \times 14 ft (150 mm \times 150 mm \times 4.4 m). This passes through snugly fittings and properly shaped bushings in the rotary table.

Drill pipes: These are hollow cylindrical pipes normally 6 in. (150 mm) in diameter with flanges provided at both ends to serve as conduit for taking out cuttings suspended in drilling water.

6) BITS

Bits are drag type ranging in diameter from 16 in. (400 mm) to 40 in. (1000 mm). They are very simple in construction. Wings of various sizes are welded in small pieces. A layer of hard metal is put on the cutting edges of these wings.

7) LINES

Lines are similar to the various types of lines used in Direct Rotary drilling.

Miscellaneous Rig Equipment

a) ROTARY TABLES

Rotary table has the same function as in Direct Rotary Drill, that is, it transmits the rotation to drill string by turning the kelly joint.

b) TRAVELLING BLOCK

Travelling block is the travelling pulley assembly which connects the drilling line, hose and swivel.

c) WATER SWIVEL

In case of reverse rotary, the water swivel is so designed that a leak in the packing, will not cause the sand pump to loose its prime. This is due to the fact that the wash pipe extends all the way down to the bottom of the kelly and therefore, the end is submerged whenever it is lowered down to drilling position.

Operation

After the rig is levelled, the derrick is raised and the sand pump is primed. The slush pit should be full of water. Kelly is then lowered till the end is fully submerged in water, discharge valve is then closed. A discharge hose or pipe is then attached and placed over the pit. All the gaskets and flanges are then checked and tightened, and the coupling on the 6 in. (150 mm) pipes properly installed. A 2 in. (50 mm) suction hose is then attached to the priming pump and placed on the pit. A 2 in. (50 mm) gate valve is opened in the priming pump and pipe plug on priming pump is removed. Priming pump is filled with water and plug is replaced. Pump is then started. Air bleeding valves are opened on top of pump bowl. Then water begins to flow from valve in the pump bowl. It is cleared when the system is completely filled, 2 in. (50 mm) gate valve is closed on priming line. The pump should operate when 6 in. (150 mm) valve is opened. A 6 in. (150 mm) gate valve should be closed before pump is stopped.

The drilling slush pits must be fairly large to hold all the cuttings which will come from the hole. The pits must be kept full of water so that the drilled hole will remain full of water and will not cave. If the water level is allowed to get down at any time, the well will cave in. To instal a bit, it will be essential to remove large drive plates in the rotary table. This gives an approximate opening of 30 in. (750 mm). If the larger opening is required, the entire rotary table must be removed from the rig which will provide 42 in. (1050 mm) clear opening. After the installation of bit, it must be lowered so that the flange of bit connection is under water. It must be properly checked that water is circulated properly before drilling is started. The 6 in. (150 mm) quick opening valve must be always closed before stopping pump, otherwise the system will loose its prime.

When drilling in formations like small modular boulders or kankar, it may be possible that these may get lodged in the suction line. Clean out holes are provided for removing these types of obstructions.

After drilling one length of kelly, the bit is removed from the end of kelly, by pulling it up to its retracted position.

The casing line is used to raise the length of pipe and bit is connected to this length of pipe and lowered in the hole. Pipe holder is inserted under the pipe flange, and is rested on rotary table. Kelly is then lowered and is connected to the drill pipe flange, pipe holder is then removed by pulling kelly up slightly. The whole thing is then lowered into the hole until the kelly foot valve has passed through the table. Hinged drive plates are closed round the kelly. Pump is then started and by rotation drilling is started. Drilling is continued till the desired depth is reached. All pipes are then pulled out and well assembly is then lowered in the hole. The hole is packed with gravel, developed and tested with compressor or pump.

Special Requisites

- 1) Considerable quantity of water, i.e., 2000 to 6000 gallons per hour is required from the time the drilling is started and till the gravel packing and well is completed.
- 2) Mud is added in water if there is caving.
- 3) The size of tank should be at least three times greater than the displacement of hole and the tank has to be kept full

of water during drilling, lowering of assembly and gravel packing.

4) Work is to be done around the clock.

5) For drilling deeper hole up to 1000 ft (300 m) compressed air is used for circulating the drilling fluid. The air eliminates priming of the circulating system.

6) The well can be developed much faster because higher velocity of drilling fluid can be maintained.

Advantages

1) Suitable for drilling large diameter hole 15 in. (380 mm) and above in soft and unconsolidated formation.

2) Suitable for gravel-packed well.

3) Well is preliminary developed during the process of drilling itself, with the flow of water into or out of aquifer.

4) As clear water is used, there is no mud invasion.

5) Well needs minimum development for maximum yield.

6) Hole is not caved at all.

7) Fastest and most practical means for drilling large diameter hole in unconsolidated formation..

Disadvantages

1) Use is restricted where ample water supply is available it needs five times more water than direct rotary.

2) Not suitable where caving is prominent.

3) Unsuitable for exploratory test drilling.

DOWN-THE-TOOL HAMMER DRILLING

Out of the recent modern development in drilling in hard rock consolidated formations, the use of down-the-hole technique has gained importance. The down-the-hole hammer method (Air actuated single piston hammer of drilling) is a combination of rotary action of rotary drill and percussion action of the percussion system. The rig consists of a down-the-tool hammer, drill string, rotary head mounting and high capacity (100-250 lb) [7 kg/cm²/sq in.-17.50 kg/cm²], (12.78 cubic metres-17 cubic metres) (450-600 cfm) air compressor. The technique uses compressed air only as drilling fluid. The hammer is down-the-hole and always at the face of rock (Fig. 4.17). The advantages of this arrangements are as follows.

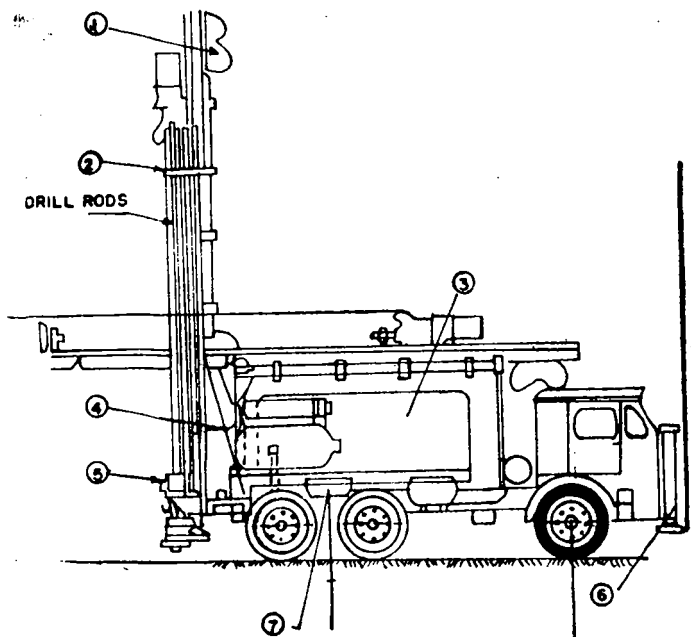

- | | |
|----------------------|-------------------------|
| 1. Top drive | 5. Hoist |
| 2. Road storage rack | 6. Levelling jacks |
| 3. Compressor | 7. Air line lubricator. |
| 4. Hydraulic wrench | |

Fig. 4.17. D.T.H. Drill

1) There is no energy loss between the striking piston and drill bit. The compressed air is used efficiently and what is more important still, that there is no loss of penetration as the hole gets drilled deeper.

2) The inter-connecting drill pipes are only required to pass the air to hammer, out through ports of drill bit and upward through the annular space, around the drill pipe.

3) The relatively large outside diameter of the hammer, helps in grinding and keeping the hole straight. This is especially valuable in weathered and inclined strata.

4) Since there is no need for large thrust on the hammer, there is no tendency of drill pipe to deviate under load, as is the case with the rotary drills. This again helps to keep the bit straight which makes the hole straight.

The air is discharged right at the bottom of hole through centre of bit. Cuttings are carried outside by air and by virtue

of return high velocity, which is termed as annular velocity. A good general rule is that minimum air velocity, for efficient flushing, should be 3000 ft/minute (909 metre/min). It is important to remember that air exhausts the hammer from high pressure to low pressure. This effectively increases in volume and velocity. If the cuttings are allowed to accumulate around the bit, the air will be prevented from expanding rapidly. Hence the carrying capacity will be lowered and there will be a restriction in the performance of bit.

This is rotary-cum-percussion method. The air media is being used for sending air through drill pipe ($4\frac{1}{2}$ in. \times 20 ft (114 mm \times 6 m) down the bits and the cutting are being carried out through annulus of the drill pipe and wall of the hole. Drilling in unconsolidated formation is being done by this method by centrifugal pump/mud pump to cover the top loose formation/over burden. The drill is fitted with water injection pump (clear water pump) is provided for sending water along with air blasts. The air supplied by compressor at 500 cfm (14 cubic metre) with 100—150 lb sq in. (7 kg/cm^2 — 10.50 kg/cm^2) or equivalent for medium sized drills and higher cfm compressor for deeper drills (700 cfm, 250 lb/sq in. or 9 cubic metre 17.50 kg/cm^2).

The air could be separately fed to the hole by additional air compressor usually truck mounted. Separate engine is provi-

Table 4.5. Details of Some Ingersoll Rand Hammers

<i>Type of Hammer and Size</i>	<i>Cylinder bore</i>	<i>Stroke</i>	<i>Blows/mt.</i>	<i>Air consumption</i>
DHD-24 $4\frac{1}{8}$ in- $4\frac{1}{2}$ in (105-114 mm)	2 $11/16$ in (68.3 mm)	6 in (150 mm)	945 at 100/psi (7 kg/cm ²) 1500 at 250 psi (17 kg/cm ²)	(i) 195 cfm at 100 psi (5.5 m ³ /min at 7-6 kg/cms ²) (ii) 500 at 250 psi (14.2 cm ³ /min at 17.6 kg/cm ²)
DHD-16A 6- $8\frac{1}{2}$ in (152-216 mm)	$3\frac{7}{8}$ in (98 mm)	$5\frac{1}{2}$ in (140 mm)	810 at 100 psi (7 kg/cm ²)	300 cfm at 100 psi (8.5 m ³ /cm ²) 7 kg/cm ²
DHD-360 6- $8\frac{1}{2}$ in (Valve less 152- 216 mm).	$4\frac{1}{4}$ in (108 mm)	$4\frac{1}{4}$ in (101 mm)	1575 at 250 psi (17 kg/cm ²) 1825 at 350 psi (24.6 kg/cm ²)	570 cm at 250 psi (16.1 cm ³ /min. at 17-6 kg/cm ²) 940 cfm at 350 psi (26.6 m ³ /min at 24.6 kg/cm ²)

des. for operating the draw works, pull-down system with hydraulic pump vane type big/small 1500 lb/sq in. (105 kg/cm²) and 30 gl/min (1.8 litres/sec). Down-the-hammer tool is H-T-150 (C-51—mission) at 100 lb/sq in. for normal operation. There are other hammers also such as Ingersoll Rand (details are given in Table 4.5). The bottom of the drill string is fitted with button/cross type of bit 6 in. size or 8 in. size (150 or 200 mm). The air is used for flushing of holes, which escapes through longitudinal ports of the hammer and through the ports, provided on the body of the bit. Minimum annulus velocity 3000 ft/mt and determined by the use of formula and also can be had from Air Velocity Chart (Fig. 4.19).

$$V = \frac{Q \times 144}{A - a} \quad A - a = \text{Annular area in sq inches}$$

V = annular velocity ft/mt

Q = free air used (cfm)

A = area of hole in sq inches.

a = area of drill pipe in sq inches.

Maximum velocity = 5000 ft/mt the ideal velocity for optimum performance is 4000 ft/mt.

The valveless hammer has single moving part, i.e., piston. The piston is hollow and slides over a fixed central control rod. The control rod has a part connecting the live air supply with the cylinder chambers via transfer annulus in the internal bore of the piston and the slot of the control rod. The position of the piston determines whether the live air supply is to be diverted to the upper chamber. If it is diverted above the piston, it moves down. If down, the piston moves above. If it is off-bottom, then air passes out without bringing in the action of the piston, without impact on hammer. This situation comes into play when the bit enters the cavity by the over-travelling of the piston and interrupting the cycle. Exhaust air travels from the exhaust parts in the control rod to improve the flushing action. The absence of valve, makes the hammer all the more simple and thus cuts short failures, which can mar and hamper its performance. The concentration of parts, into a central control rod, helps simplicity but reduces the effective area of the piston which would have provided, heavier impact with valve type hammer. The down-the-hammer must be strongly constructed with strong cylinder casing. With the down-the-

tool-hammer, the hole diameter must be necessarily larger than the hammer and the piston diameter will be smaller. It can drill hardest formation but its performance results are best obtained on rocks of medium hardness. For improving drilling speed, higher air pressures are coming into vogue. Usually down-the-hammer rig has 150 lb/sq in. (10.5 kg/cm²) 85-100 lb/sq in. (5.6 to 7 kg/cm²) are used depending on the air supply available with a choice to give 4 in. (100 mm) or 6 in. (150 mm) holes. Because of the limitation of piston size, imposed by the size of the wall of the hole, power improvement can be made by: (i) increasing air pressure; (ii) increasing stroke; and (iii) or decreasing piston weight.

Increasing the size of the stroke by (ii) leads to higher piston speed but fewer blows per minute, neither of which gives the result by (iii), it gives gain at the expense of higher piston speed and increased maintenance.

Using higher air pressure without modification to hammer, gives increased energy for blow and also increased piston speed and number of blows per minute. By reducing stroke and decreasing piston weight and adjusting pressure, can bring the desired penetration performance. One of the disadvantage of down-the-hole-drilling, is the inconsistent life expected of bits, due to short distance between piston and rock face due to poor transference of energy. As bits costs are major item, it has been found that button type bits have given encouraging results. To provide the cutting surfaces, these alloy steel bits have cylindrical inserts of tungston-carbide each with spherical end finish, replacing conventional chisel-shaped bits. Those who don't sharpen the bits or are not much conversant with correct fashion methods, button bits are much suited. These button bits, give smooth performance and less torque, higher rate of penetration, less wear on equipment, easier and less risk of jamming. The high pressure is capable of giving better performance with these type of bits because of small rotational wear per unit length of the hole drilled. Proper rotational speed is from 10 to 30 rpm; reduced speed is best, in harder and abrasive rocks. In down-the-hole drilling, the drill pipes are hollow and thus very much suited for flushing and also efficient. The drill stems (4½ in. × 20 ft) (114 mm × 6 m) are heavy and screwed, with API end connection and thus are in position to meet static

requirement of load, for deeper holes and gives positive thrust in shallow holes. The rotary head could be pneumatic or hydraulic, it is to be infinitely variable to suit to the rotation meant for particular rock condition being encountered.

Sketch of Down the Tool Hammer (Low Pressure Hammer Drill) (Fig. 4.18).

The costs per ft of drilling with D.T.H. drill is sensitive to the life and cost of the bits. It is only through experience the choice for proper type of bits could be made for penetration of the particular formation.

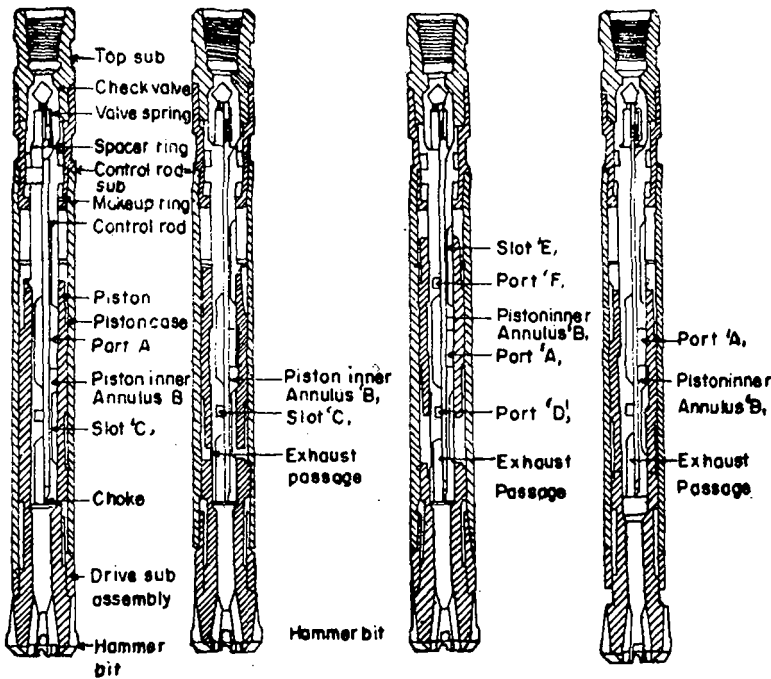

Fig. 4.18. Low Pressure Hammer Drill

A practical advantage of D.T.H. (air rotary) is that the driller can know as to how much water is blown out with air, with cuttings as the hole gets deepened. Thus he can visualise as to how much water could be expected by him as the depth is increased or whether hole is deep enough to have the required and desired yield.

From the field experience, it has been seen that penetration

rate is often faster (an average of 20-25 m/shift). Bit life is longer as compared to mud drilling. The better bottom hole clearing is responsible for better performance than any other type of drilling. However, it has been felt that while encountering water bearing formations, the rate of penetration gets slowed down as compared to the fact when the hole is dry. To achieve all this, cleaning/oiling the hammer after 10 to 40 m is must if we have to ensure better/efficient service from the hammer; 16 to 18 litres of rock oil AROX—Servonum 105 is needed for eight hours; water is injected along with the regular blasts of air being used as fluid media.

Average progress is 80 to 100 m in three shift and in compact formations. Best suited for consolidated and hard formations.

Foam drilling is also resorted to. It has the following advantages:

- 1) Wet cuttings could be removed from the hole with less pressure.
- 2) Sloughing is reduced because of stabilisation of pressure.
- 3) Penetration rate and bit life is improved.

Water is injected with foam to disburse the cutting if insufficient cuttings are entering the bore well. To the mixture of bentonite 20 to 25 lb, 1 to 3 lb of soda ash and .5 to 2 lb of organic polymore is added in 100 gl of water. To this slurry, .5% quantity volume foaming agent is added to avoid entrapment of air. A controllable low volume injection pump is necessary. By trial/and error method and by changing the variation of mixture, the mixture is so injected so that optimum return velocity is obtained. When using foam system only reduced air pressure is recommended.

Recommended pre-requisites for efficient performance of the hammer drill are as follows:

- 1) The pressure required to operate the hammer is 100-250 lb/sq in. and cfm 700.
- 2) Blows/mt come in the range of 600 to 1200.
- 3) Annular air velocity is to be maintained from 3000 to 5000 ft/mt.
- 4) Recommended pull down pressure 150 to 750 lb per inch diameter of the bit.
- 5) Optimum rotational speed is 15 to 50 rpm (Table 4.6).

FOAM DRILLING

When drilling is done through the formations that contain enough water to produce wet cuttings, a mud ring is formed. If the flow of water entering the hole is too high, foam drilling is resorted to. It has the following advantages:

- 1) Allows the wet cuttings to be removed with less pressure.
- 2) Reduction of sloughing with pressure stabilisation.
- 3) Rate of drilling and bit life is improved because of stabilisation of pressure.

Figure 4.20 gives three positions as described. It gives

- a) the flow when only air is used in dry formation.
- b) the flow when air is used in wet formation.
- c) the flow when air and foam is used in wet formation.

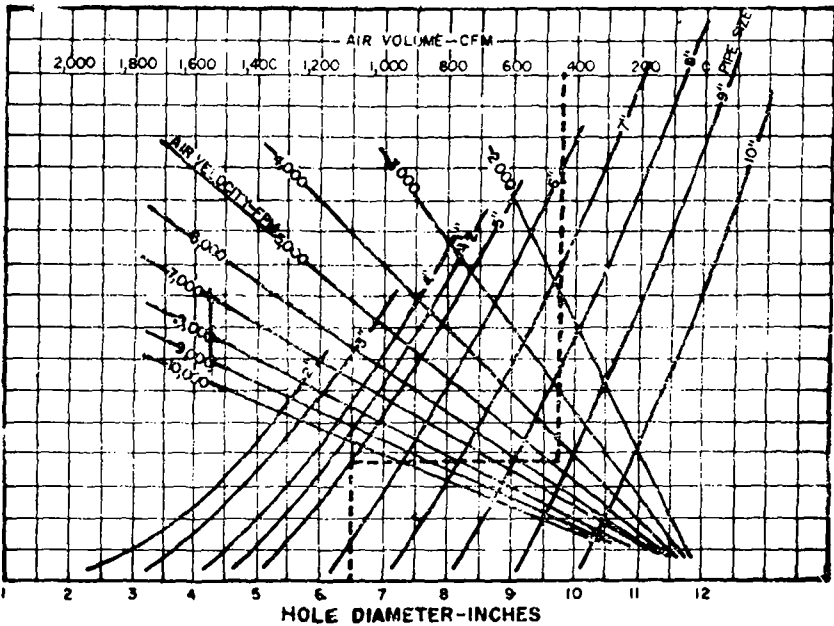

Fig. 4.19. Air Velocity Determination Chart

To determine air velocity in annulus when pipe size, hole diameter and air volume are known, follow vertical Hole Diameter line upward to its intersection with Pipe Size line. Move horizontally to intersect Air Volume line. Read Air Velocity on diagonal Air Velocity line.

Table 4.6. Rotary and Percussion Drill Performance (After NWWA)

Type of formation	Percussion drill	Rotary drill (with fluids)	Rotary drill (bottom-hole air tool)	
Dune sand	Difficult	Rapid	} Not Recommended	
Loose sand and gravel	Difficult	Rapid		
Quicksand	Difficult, except in thin streaks. Requires a string of drive pipe.	Rapid		
Loose boulders in alluvial fans or glacial drift	Difficult—slow but generally can be handled by driving pipe.	Difficult, frequently impossible		
Clay and silt	Slow	Rapid		
Firm shale	Rapid	Rapid		
Sticky shale	Slow	Rapid		
Brittle shale	Rapid	Rapid		
Sandstone—poorly cemented	Slow	Slow		
Sandstone—well cemented	Slow	Slow		
Chert nodules	Rapid	Slow		
Limestone	Rapid	Rapid		Very Rapid
Limestone with chert nodules	Rapid	Slow		Very Rapid
Limestone with small cracks or fractures	Rapid	Slow		Very Rapid
Limestone, cavernous	Rapid	Slow to impossible		Difficult
Dolomite	Rapid	Rapid	Very Rapid	
Basalts, thin layers in sedimentary rocks	Rapid	Slow	Very Rapid	
Basalts—thick layers	Slow	Slow	Rapid	
Metamorphic rocks	Slow	Slow	Rapid	
Granite	Slow	Slow	Rapid	

Foam drilling is a method of drilling unconsolidated rocks with low density fluids. With this the annular velocity is 100 to 200 feet per minute. The compressor requirements are reduced. 20 lb of bentonite, 1 to 2 lb of soda ash and 1-2 lb of polyphosphates are mixed in 100 gallons of water, then to this slurry 1 per cent of foaming agent is added. The mixture is injected into the hole by low injection pump used for foam drilling. By experiment and trial at site, the drilling in unconsolidated and water sensitive formation, have proved successful with foam drilling method as shown in Fig. 4.20.

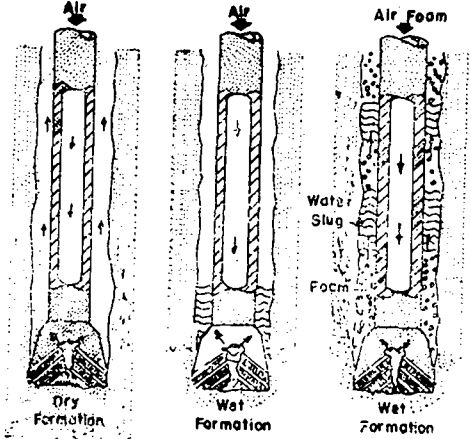

Fig. 4.20. Foam Drilling

Choice of Drilling Rigs

The purposes of drilling are:

- 1) to collect formation samples,
- 2) to collect water samples or allow assessment of water quality,
- 3) to permit geophysical logging,
- 4) to establish water level measuring points, and
- 5) to conduct pumping tests for collection of hydrological data.

For rapid, accurate and economic investigation through test drilling or subsequent production programme, it is important that correct choice of drills for a given job requirement be made, keeping in view the constraints of each type of rig so that operations may be run smoothly. A broad indication for suitable selection of drill vis-a-vis formation/discharge/depth are as follows.

Alluvial Formation

- 1) Drilling in dug wells.
 - i) Hand boring.
 - ii) Light percussion rig.

Hand boring is usually employed. For deeper drilling, light percussion rigs are more suited.

- 2) Drilling shallow wells where discharge is less than one cusec, the choice could be made from one of the listed methods of drilling.

- i) Hand boring.
- ii) Light percussion rig.
- iii) Light direct rotary rig.

iv) Light reverse circulation rig.

Hand boring and light percussion rigs are best suited, being economical for cavity and strainer wells. Light rotary and light percussion rig would be preferred for gravel packed wells, being faster and more economical. Reverse rotary drills move faster requiring less development time but are only suitable for non-caving formations and where there is plenty of water available for drilling.

3) Drilling medium capacity tubewells in which the discharge is 1-2 cusecs.

i) Medium percussion rig.

ii) Medium direct rotary rig.

iii) Medium reverse circulation rig.

Medium direct and reverse circulation rigs drill faster but percussion would be more effective if boulders or clay-sand mixed boulders are met. The position regarding the reverse drills remain unchanged as given under light reverse drills.

4) Heavy capacity tubewells where the discharge is 2-5 cusecs.

i) Heavy percussion rig.

ii) Heavy direct rotary rig.

iii) Heavy reverse rig.

Heavy percussion rig would be preferred for drilling in bouldery formation and direct rotary rig will have preference over reverse drills due to their inherent limitations as given above.

Semi-consolidated and Unconsolidated Formations

1) Drilling in dug wells.

There is difficulty in setting up direct or reverse drills over the dug wells and circulation of drilling fluid.

2) Light to medium capacity tubewells.

i) Medium percussion Rig.

ii) Medium direct rotary Rig.

iii) Rotary-cum-percussion Rig.

Medium percussion rigs are deployed where semi-consolidated formations are harder and predominant. These are also suitable for fissured cavernous and lost circulation zones as well as boulder formations.

Medium direct rotary rig is suitable where unconsolidated formations are encountered.

Consolidated Formation

- 1) Drilling in dug wells.
 - i) Medium percussion drill.
 - ii) Down the hole hammer drill (D.T.H.).
 - iii) Air-cum-rotary percussion drill.
 - iv) Calyx drill.
 - v) Diamond drill.

For drilling in dug wells medium percussion drills are suitable though slow. D.T.H. is suitable for hard formations for small diameter wells of 6 and 8 inch (150 and 200 mm). Air-cum-rotary percussion drills are employed where small and horizontal points are to be drilled which can be taken up inside the well. Calyx drill and diamond drills are suitable for taking cores and for placement over bore-cum-well. Diamond drills drill faster but are expensive.

- 2) Light and medium capacity wells.
 - i) Medium percussion drill.
 - ii) D.T.H. drill.
 - iii) Air-cum-rotary and percussion drill.
 - iv) Calyx drill.
 - v) Diamond drill.

Medium percussion drill would drill bigger holes for moderate depth but the progress would be very slow in hard formations. D.T.H. drill would be suitable for drilling 6 to 8 inch hole to moderate depth at faster rates. Air-cum-rotary percussion drill would be preferred for smaller holes in hard formations overlaid with overburden. Calyx and diamond drills would be uneconomical for drilling irrigation wells.

It is stated in nutshell that for softer formations, percussion drills are best suited and for compact rock, air rotary/D.T.H. are the ideal one. Percussion drills are much slower and can be expensive due to casing placement. However, rotary drill is commonly employed covering all contingencies of drilling that may occur giving the advantage of speed. Reverse circulation drills can be used for production programme but these can only be economical when large diameters are required. In water shortage are as and in water lost circulation zones, it is not feasible.

The entire sequence has been given in Table 5.1 and type of rock vis-a-vis bit is given in Table 5.2. To have an idea of bit performance, Table 5.3 gives the hardness classification, mini-

Table 5.1. Details of Type of Wells and Choice of Drills

Type of geological formation	Type of wells	Type of drilling rig
<i>Alluvial Deposits :</i> Comprising clay, kankar, silt, sands, gravels and boulders.	Dug well	i) Hand boring machine. ii) Low capacity percussion drill
	Tubewells (shallow and deep)	i) Percussion ii) Direct rotary iii) Reverse rotary iv) Combination rig
<i>Semi-consolidated Rocks :</i> Comprising dipping sandstone, <i>grits</i> , limestones, quartzites etc.	Dug wells and Tubewells	i) Percussion rig ii) Rotary rig iii) Combination rig
	Dug-cum-bore wells	i) Light duty percussion. ii) Down-the-hole-hammer (D.T.H.)
<i>Consolidated Rocks :</i> Comprising granites, gneisses, basalts and other crystalline hard rocks.	Borewells or tubewells	i) D.T.H.

imum/average rate of drilling, maximum bit life and average bit life so that we can ensure that the maximum life and progress is achieved with these bits in D.T.H. drilling.

Table 5.2. Type of Rock Formation and Bits

Type of rock formation	Type of bit
1. Earth	Auger
2. Granites, Gneisses, Basalt, Quartzites, Dolomite, Marble, Sandstone	Hammer bit
3. Slate, Limestone, Shale	Rotary tricone
4. Clay, Gypsum, Coal, Graphite	Drag bit

Table 5.3. Performance of Hammer Drilling

Formation	Hardness classification	Maximum drilling rate (ft/hour)	Average drilling rate (ft/hour)	Maximum bit life (ft)	Average bit life (ft)
Sandstone	Soft	20	16	1275	900
Iron ore	Soft	23	16	1275	900
Shale	Soft	25	19	1500	1100
Limestone	Medium	23	19	1500	1100
Dolomite	Medium	15	11	1000	700
Granite	Hard	14	9	525	375
Trap rock (Basalt)	Hard	11	8	625	450
Quarty	Hard	8	6	150	140

Choice of Rig Mounting

The choice of rig mounting is governed by the conditions encountered at site. The drills would be skid, truck, trailer or tractor mounted. Tractor mounted would be suitable when the rig is operated in hilly terrain. Truck mounting are prepared for quick and easy shifting, heavy drills are trailer mounted and can be handled with tractors/trucks. The weight limitations imposed due to bridges/paths are to be kept in view after deciding as to which mounting would be most suited.

Choice of H.P. Rating for Rig Engines

Generally high speed diesel engines are used with rotary and percussion rigs as they are found to be of dependable service and economical. In pilot drilling, a net H.P. of 100 is required for 1000 ft of pilot hole drilling. It is necessary to provide identical engines, one engine for drilling and the other for Mud Pump for greater efficiency and both can be coupled through compound case system. The rated H.P. of percussion rigs is governed by its rated capacity of handling tool weight and casing weight.

- | | | |
|---|---------|----------------|
| 1) Light percussion up to 500 feet | 1500 lb | |
| tool weight capacity. | | 20-40 H.P. |
| 2) Medium percussion rigs (2000 to 3000 | | |
| lb) tool weight capacity. | | 75-100 B.H.P. |
| 3) Heavy percussion rigs (3500 to 5000 | | |
| lb) tool weight capacity. | | 125-175 B.H.P. |

Engine of Higher capacity both for percussion and rotary drill can be installed under difficult drilling conditions.

Choice of Mud Pump

Duplex double acting pumps are used with direct Rotary rigs as they are capable of developing maximum pressure for deep drilling and handling viscous fluids. The volume capacity of mud pump has direct relation to the size of the hole and is worked out from the velocity of mud fluid for effective drill cutting removal. The ideal return velocity of mud is 36 m to 54 m/minute. The pressure capacity is related to pressure losses in circulating system. Generally the following sizes of mud pump are considered adequate.

- | | |
|----------------------------|--|
| 1) Light direct rotary rig | Bore 125 mm, stroke 150 mm,
capable of delivering 28,800— |
|----------------------------|--|

- 40,500 litres/hr at a pressure of 21 kg/cm².
- 2) Medium direct rotary rig Bore 125-150 mm, stroke 200 mm, capable of delivering 21,000-40,500 litres/hr at a pressure of 17.5-28 kg/cm².
- 3) Heavy duty rotary rig Bore 190 mm, stroke, 252 mm, capable of delivering 13,500-81,000 litres/hr at a pressure of 17.5 kg/cm².

Classification of Drills

<i>Type of drill</i>	<i>Hook load rated cap</i>	<i>Drilling depth</i>
1. Light direct rotary drill	9,100 kg	240 m
2. Mud rotary drill	13,650-18,200 kg	460-690 m
3. Heavy duty direct rotary drill	72,720-45,440 kg	750-1050 m
	<i>Tool weight handling cap</i>	<i>Depth</i>
4. Light percussion drill	500-1000 kg	100 m
5. Medium percussion drill	1000-1500 kg	200 m
6. Heavy percussion drill	1500-3000 kg	300 m

Well Logging

After the boreholes are drilled, they are logged by lowering in a hole, electrical sensing devices.

Purpose of well logging is to identify geological formations which are penetrated in a hole and the fluid material contained by such rock formations.

Well logging methods principally define two main properties of boreholes:

- 1) Definition of permeable bands; and
- 2) Ground water quality of a test well and or a production water well.

Logging techniques identify permeability zones in an alluvial formation borehole. It locates fractures and zones of secondary permeability in a hard rock well. Logging also helps in regional correlation of aquifers.

Various methods of well logging are listed as under:

- i) Self-potential (Sp)
- ii) Single point resistance
- iii) Resistivity
- iv) Natural gamma
- v) Neutron
- vi) Caliper
- vii) Flowmeter
- viii) Television Logging
- ix) Conventional Logging Methods.

i) Self-potential (Sp)

They are records of electrical potential in a borehole. The main cause of such a potential is because of difference in con-

centration of ions of borehole fluid and that of rocks in the immediate surrounding of a well. Such a log is used for aquifer correlation and determination of depth of occurrence and thickness of a water bearing aquifer. It has its best use in alluvial as well as sedimentary rock formations.

ii) Single Point Resistance

Single point method though expensive is a simple and most reliable logging device for locating precise position of a water bearing bed in a borehole and making correlation over an area. In such logs, the resistance always increases to the right hand side even when very thin beds are punctured in a hole. This method, however, does not provide quantitative measurements. It is a useful method of logging within alluvial and hard rock formations.

iii) Resistivity

Resistivity logs yield data on formation lithology and mud filtrate invasion and true formation-resistivity. These logs are normally taken in a hole located in crystalline hard rocks such as massive or fractured granites or basalts. A typical resistivity log of a borehole is shown in Fig. 6.1.

iv) Natural Gamma

Natural gamma logs record gamma-radiation emitted by rock formations. This method has the advantage of being carried out in open or a cased well, dry or fluid carrying borehole. It is run normally in a borehole located in relatively impervious formations which have mostly punctured clay and shale horizons. Hard rocks such as gneisses, limestone etc. register varying degree of gamma-radiation. Felspathic rocks would record high gamma-radiation because their weathering products are rich in clay and kaoline.

v) Neutron Log

Neutron logs are useful for measuring soil moisture above the zone of saturation. They are also obtained in open or cased wells in dry or fluid containing wells. Such logs determine the relative porosity. In such a log, a sharp deflection in the curve to the left indicates fracture zone of a hard rock borewell.

LOGGING DEPTH:- 78.0 m.b.g.l. LOGGING DATE 10.8.87
 DRILLING DEPTH:- 78.0 m.b.g.l.
 TYPE OF LOGGER:- NIMS 3200 (MULTICHANNEL)

SP
 2.5mV/DIA

POINT RESISTANCE
 2 Ohms/DIV

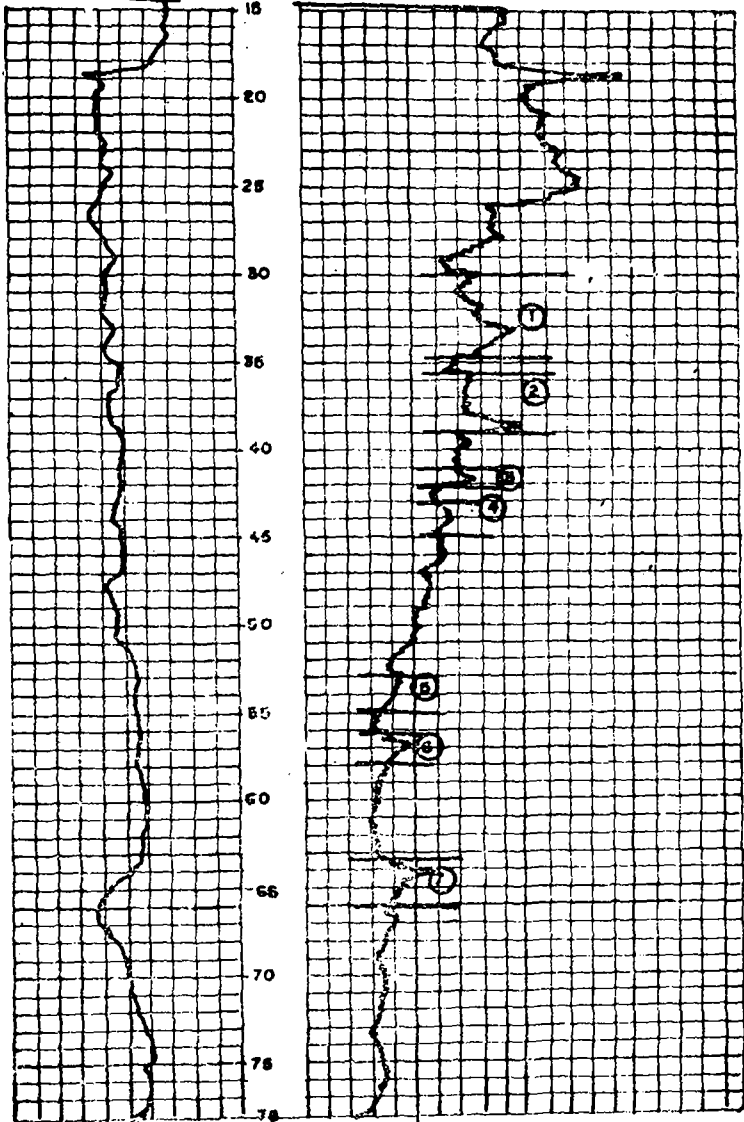

Fig. 6.1. Resistivity Log Chart

vi) Caliper Log

Logs taken by other methods are effected by change in the hole diameter. Caliper logs provide correct interpretations for such a changed situation. The change in the diameter of a hole is a function of the nature of formation, and fracturisation and cementation. The fractured zones and their width can be interpreted on caliper logs and these provide useful data for designing wells in a hard rock region.

vii) Flowmeter and Temperature Logs

It is a method borrowed from petroleum industry. Flowmeter and differential temperature should combine with logs taken by resistivity, natural gamma and caliper methods to study the pattern of water circulation through cracks. Temperature anomalies of the order of 0 to 2°C are recordable, the size of the anomaly reflects the size of the water velocities.

viii) Television Logging

It is a remote sensing method of borehole investigation. It yields direct visual observations of the rock outcrops exposed in well section which is not possible to be observed by any other method. The undisturbed well waters having low turbidity permit visual logging with a closed circuit television system. Television cameras are run at a logging speed of 2 metres/minute and recording is carried out on videotape. The interpretations are done at well site itself. It is useful in the evaluation of fracture system in hard rock wells. A combination of caliper and television logging would be ideal in estimating extent of fractures in relation to well yield.

Present techniques of well logging, especially for hard rock regions, need research and development efforts and perhaps there is a scope for development and application of acoustic amplitude logging and more sophisticated tracer methods.

ix) Conventional Well Logging Methods

Other valuable methods of analysing the sub-surface formation is by examination of various logging records which are available.

- 1) Driller Log.
- 2) Cutting Log.

i) WELL DEPTH

Normally a well is finished up to the bottom of the aquifer. This is essential to puncture full thickness which causes higher specific capacity and higher yield.

ii) WELL DIAMETER

The choice of well casing is related to well diameter for purposes of housing pump. The diameter of perforated portion of well section is so chosen as to increase well efficiency.

The diameter of the well casing should be two sizes larger than the usual diameter of the pump. In deeper well structures where static and pumping water levels are high, the well diameter should be reduced at a depth below the lowest anticipated pump setting. This is done by telescoping the well structure.

The lower or intake well section may not necessarily have the same diameter as the housing pipe. In case of deeper wells, reduction of well diameter below the well casing is recommended. Screen diameter is so provisioned as to open large area for ensuring entrance velocity of 0.1 ft/sec (3 cm/sec.).

iii) LENGTH OF HOUSING PIPE

The length should be sufficient to facilitate pump installation.

Due allowance is made of the following factors:

- Seasonal and periodic variation of static head,
- Drawdown,
- Interference effect, and
- Submergence needed for the pumps.

iv) WELL SCREEN LENGTH

Increase in the length of the well screen will yield much more water effectively compared to increased screen slot aperture and screen diameter. The thickness of the water bearing material effects the selection of a screen length. Thus its selection is dependent upon aquifer thickness, drawdown, and aquifer stratification.

The ideal situations for artesian and water table aquifers are described below.

Artesian aquifer: In homogeneous artesian aquifers about 75 per cent of the thickness of the saturated material is screened provided the pumping water level is not below the top of the

aquifer. If aquifer is less than 8 metre thick the screening of 65 to 70 per cent length is satisfactory. If it is 8 to 15 metre thick, 70 to 75 per cent of the thickness should be screened.

If it is greater than 15 metres, 75 to 80 per cent of thickness should be screened. For wells finished in an aquifer of greater than 15 metre thickness, it is always ideal to screen 80 per cent of the thickness as far as possible.

In non-homogeneous artesian aquifer it is appropriate to screen the most permeable portion of the aquifer.

Water table aquifer : Practically it has been experienced that screening the bottom 1/3rd of the water bearing zone provides optimum design. In some cases the lower half of the aquifer is screened for improved well efficiency. In non-homogeneous aquifer, the screened portion is restricted to the lower half of the aquifer section.

v) WELL SCREEN SLOT OPENING

The size of screen slot opening is limited by the size of fine materials to be removed from well during its development.

The limiting size is obtained by sieve analysis of aquifer samples using various sieve sizes as given in Table 7.1.

Various types of ideal sieves are listed below.

A sand analysis curve is achieved for each sample collected at the time of drilling operation.

i) For a uniform formation which consists of fine graded uniform sand, the size of screen opening is so selected as to retain 40 to 50 per cent of the sand.

ii) The 40 per cent of size is usually selected when ground water is not corrosive.

iii) The 50 per cent of size is chosen if the water is extremely corrosive.

To basic additional rules which can be applied in the selection of openings are as follows.

i) If coarser material is overlain by finer material, extend not less than 0.60 metres of the screen with the slot size designed for the fine material down into the coarse strata below.

ii) If coarser material is underlain by finer material the slot size for the screen section to be installed in the coarser layer should not be more than double the slot size for the overlying finer material.

Table 7.1. Sieve Sizes

<i>Mesh no.</i>	<i>BSS</i>	<i>ASTM</i>	<i>ISS</i>	<i>MICRONS/MM</i>
	4	5	480	4.75
	5	6	440	3.35
	6	7	280	2.80
	7	8	240	2.36
	8	10	200	2.00
	10	12	170	1.70
	12	14	140	1.40
	14	16	120	1.18
	16	18	100	1.00
	18	20	85	850
	22	25	70	710
	25	30	60	600
	30	35	50	500
	36	40	40	425
	44	45	35	355
	52	50	30	300
	60	60	25	250
	72	70	20	212
	85	80	18	180
	100	100	15	150
	120	120	12	125
	150	140	10	106
	170	170	9	90
	200	200	8	75
	240	230	7	63
	300	270	6	53
	325	300	5	44
	350	325	4	45
	400	380	3	40

vi) TYPE OF SCREEN

The following type of well screens are normally used.

- i) Continuous screen pipe.
- ii) Shutter type well screen.
- iii) Pipe base well screen.
- iv) Slotted pipes (Fig. 7.1).

It is desirable to describe here machine cut slotted pipes. In the machine cut slotted pipe, commonly used in this country, 15 to 20 per cent open area is commonly available. 1/16 inch slot matches with No. 60 screen of Johnson and 1/8 inch slot lies between 100 to 150 of Johnson screen. For machine cut

slots, which are used in artificially gravel packed wells an open area of more than 15 per cent is considered sufficient.

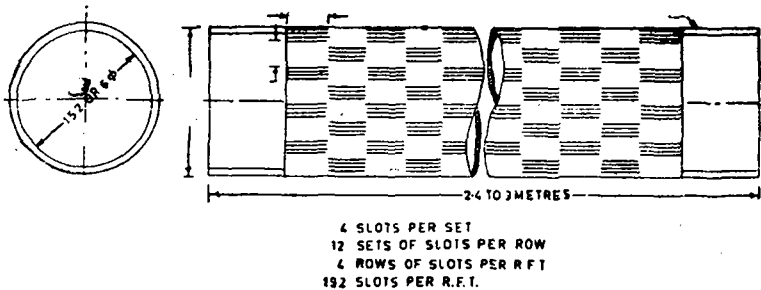

Fig. 7.1. Six Inch Slotted Pipe

Choice of Material for Well Structure

It is also an important aspect of well design. The main factors which control choice of material are:

- i) Water quality.
- ii) Material strength.
- iii) Cost.

i) WATER QUALITY

Water causes corrosion as well as incrustations. Corrosion of a well screen would cause well failure. It is imperative thus to use a well screen fabricated of a corrosion resistant material.

ii) STRENGTH REQUIREMENT

It is an important requirement in screen than in casing. Screen made of stainless steel has twice the strength than that of a copper alloy.

iii) COST

The use of costly materials should be very well weighed against the life of a well.

Packing and Formation Stabilisation

During the development of a well finer material from the vicinity of the well screen is removed, leaving the zone of coarser graded material around the well. This cannot be achieved in a formation consisting of a fine uniform sand due to the absence of any coarser material. The object of gravel packing in a well

is to artificially provide the graded gravel or coarser sand that is missing from the natural formation. A well treated in this manner is referred to as an artificially gravel packed well to distinguish it from the naturally developed well (Fig. 7.2).

Drilling by the rotary method through an unconsolidated water bearing formation results in a hole, somewhat larger than the outside diameter of the well screen. This provides the necessary clearance to permit the lowering of the screen to the bottom of the hole without interference.

The object of formation stabilisation is to fill the annular space around the screen (possibly 2 inch (50 mm) and more in width) at least partially, to prevent the silt and clay materials above the aquifer from caving or slumping when the development work is started. These differences in objectives of gravel packing and formation stabilisation form the basis for the differences in the design features of the two processes.

Gravel Packing

There are essentially four conditions which tend to favour artificial gravel pack construction.

i) OCCURRENCE OF FINE UNIFORM SAND IN THE AQUIFER

Such a sand would require a screen with very small slot openings and even so, the development process would not be satisfactory because of the uniformity of the sand particles. Also screens with very small slot opening have low percentages of open area because of the relative thickness of material that must be used to provide strength. The use of artificial gravel pack construction is recommended in formations where the screen opening selected on the basis of a naturally developed well, is smaller than 0.1 inch or No. 10 slot of Johnson.

ii) FORMATION STABILISATION

In naturally developed wells, drilled by the hydraulic rotary method, clean coarse sand, or a sand gravel mixture is introduced to fill the annular space around the screen and casing to a level of about 10 metres or as much as is practicable, above the top of the screen (Fig. 7.2). This process of formation stabilisation would allow for settlement and losses of material through the screen during development. If necessary more material should

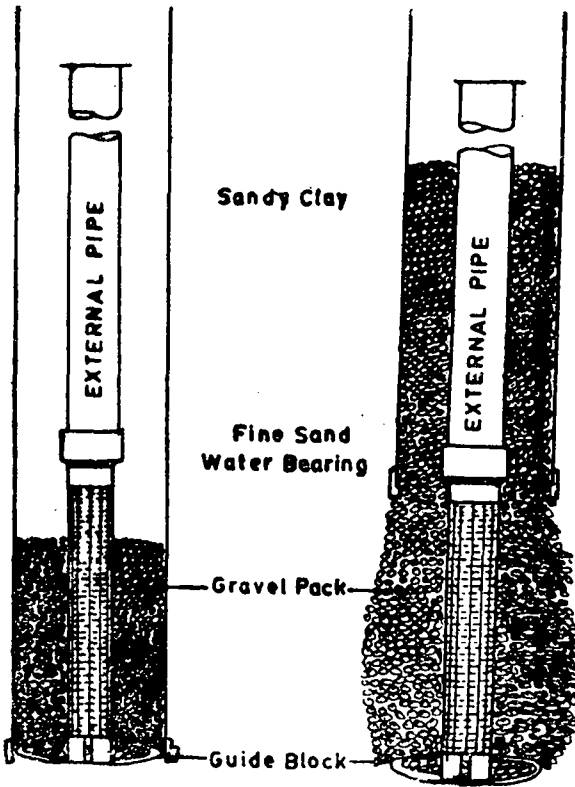

Fig. 7.2. Gravel Packed Well

be added, as development proceeds, to prevent its top level from falling below that of the screen. The formation stabiliser is less uniform and need not be of such special gradation as an artificial gravel pack. A sand mixture of a grading about the same as, or slightly coarser than the water bearing formation itself will work best.

Size of the well screen openings should be selected to permit proper natural development of the aquifer materials around the screen just as if no formation stabiliser, together with the fines from aquifer, will be brought through the screen openings during the development process. This contrasts with the procedure in artificial gravel packing where the screen openings are deliberately chosen of such size as to retain virtually all the particles

of an artificial gravel pack. No special precaution needs to be taken in placing the formation stabiliser such as are usually employed in placing specially graded gravel pack. The material can be allowed to settle in the drilling fluid around the well casing and around the well screen without using a special pipe.

The extraction of the finer particles from the formation stabilises while removing fines from the natural formation. At the same time it helps significantly to break the mud cake from the wall of the drilled hole in the screened section of the well. Development work shifts and agitates particles of the formation and stabilised material tends to erode the mud wall that was formed during the drilling operation.

iii) GRAVEL PACK PROPERTIES

The gravel pack material should have the following properties:

a) Its 70 per cent size should be four to six times the 50 per cent size of the material of the aquifer to ensure that the gravel pack material will not restrict the flow from the layers of coarsest material, the permeability of the pack being several times that of the coarsest stratum.

b) Its uniformity coefficient is less than 2.5 and the smaller the better. Uniformity coefficient is the number expressing the ratio of the 40 per cent size of the material to its 90 per cent size (sizes refer to the percentage retained on a given sieve during sieve analysis). This condition ensures that the losses of pack material during the development work will be minimal. To achieve this goal, the screen openings are chosen so as to retain 90 per cent or more of the gravel pack material.

c) Gravel pack material should be clean well rounded grains that are smooth and uniform. These characteristics increase the permeability and porosity of the pack material. Gravel pack material consisting mostly of siliceous, rather than calcareous particles is preferred. Up to 5 per cent calcareous material is a common allowable limit. If calcareous material is more during acid treatment most of the acid could be spent in dissolving calcareous particles of gravel rather than in removing incrustating deposits of calcium or iron from well screen. Particles of shale and anhydrite and gypsum in the gravel pack material are also undesirable.

iv) THICKNESS OF GRAVEL

Laboratory tests have shown that a gravel pack with a thickness of only a fraction of an inch can successfully retain the formation particles regardless of the velocity of water tending to carry the particles through the gravel pack. However, to ensure that an envelope of gravel well surrounds the entire screen, a thickness of 3 inches (75 mm) is the minimum required. The upper limit of gravel packing should be about 8 inches (200 mm). A thicker envelope does not materially increase the yield of the well and thickness in itself does nothing to reduce the possibility of sand pumping because the controlling factor is the ratio of the grain size of the pack material to the formation material. Too thick a gravel pack can make final development of the well more difficult.

A representative sample is obtained by quartering and coning. It is washed with clean water and then with dilute hydrochloric acid and dried. A known weight of sample is passed through standard sieves of various sizes. The fraction retained in each mesh are weighed. These weights are then converted in terms of percentage and then the cumulative retained on each sieve is plotted. From the plot the various sizes of sample are found out by calculation of slot size, gravel size and uniformity coefficient which are described below:

- a) Slot size, 40 per cent of the aquifer material to be retained on slot.
- b) Gravel pack, four or five times the 50 per cent size of formational material.
- c) Uniformity coefficient 40 per cent over 90 per cent size.
- d) If uniformity coefficient is less than 3 then well does not need gravel packing.
- e) Thickness of gravel is not more than 3 to 4 inches (75 to 100 mm).

Measurement of Eccentricity—Disc Instrument

A well should be tested by a small disc-cylinder (Fig. 7.3) made of two discs joined together 6 mm smaller in diameter than the inside bore of the well casing. A tripod with a pulley is placed over the tubewell. The disc is suspended by wire running over the pulley at least 3 metres above the top of the well so that the wire passes through the centre of cylinder or well.

For deep well turbine pump, casing less than 35 cm in diameter and the verticality should not deviate more than 10 cm per 30 metre depth. The deviation should be in one direction and plane only (IS 2800—1964).

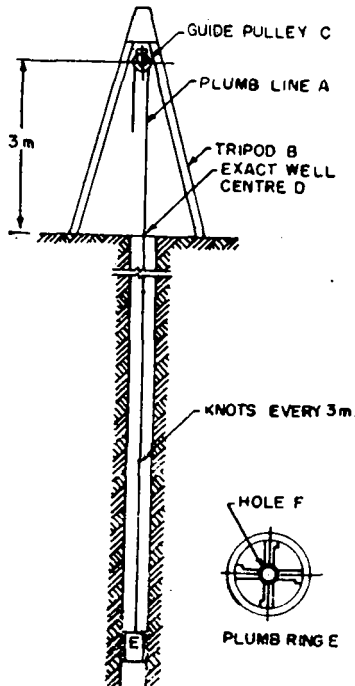

Fig. 7.3. Eccentricity Disc

The disc is lowered in steps of 3 metres and the deviation is measured from centre line of casing.

$$\text{drift at any depth} = \frac{\text{deviation} \times \text{length of line}}{\text{Height of pulley above top of well casing}}$$

If the eccentricity is not within permissible limits, it is to be corrected or a fresh well made.

Well Construction

A) CONSTRUCTION OF WELL IN ALLUVIAL FORMATION

After the well has been electrically logged and the design of assembly of 6 or 8 inches (150 mm or 200 mm) blank and slotted size of slot is decided, steps are taken to lower the same duly welded in the centre of the well. The procedure adopted for construction of well by rotary and percussion drills etc. are given below.

I) Rotary Drilled Wells

After well assembly is lowered in the hole water is pumped in the assembly through mud pump with top closed. Water which is neither muddy nor clear is used for the purpose. The gravel is kept shrouded so that the well is duly packed, and there is no bridging of any kind. This would allow water to go from assembly slot to the formation and wash the mud effect enabling the formation to come in contact with the slotted pipes having in between them the cover of gravel pack. This has been a very successful method for lowering of assembly and shrouding the well. Immediately the compressor is started so that the effects of mud cake if still left, could be washed and water is made sand-free with running of compressor for 40 to 60 hours. Gravel is kept fed in case it sinks during compressor development. Then the turbine pump is run for final test.

Cement Sealing

At times, it is required to construct test well which tap a single aquifer. In such a situation, a cement pack is to be provided in

the confining clay zone. A gravel is initially packed/shrouded up to the level where cement seal is to be provided. Once the gravel is set cement slurry is poured over it through the pipe and allowed to set over 24 hours over which clay and local material is filled up to ensure that gravel packing of aquifer Feed pipe for gravel is provided through cement seal in aquifer.

II) Percussion Drilled Wells (Fig. 8.1)

The well assembly comprising of housing, slotted pipe, blank pipe are lowered duly welded inside the drive pipe which have been sunk at the bore well site.

The slotted pipe is placed facing the aquifer and the blank pipe against clayish and other formation. The appropriately selected washed gravel is fed in the annular space around the screen in the driven casing in the batches of few feet filling at a time. The driven pipe is extracted or jacked out side by side. This procedure is repeated till the level of the gravel reaches above the screen and outside the housing near the top of well.

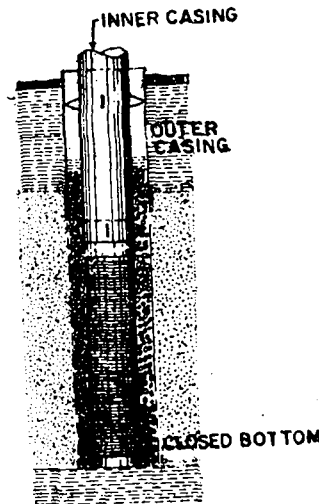

Fig. 8.1. Artificially Gravel Packing a Well with Extraction of Casing

Precaution is to be taken that sufficient gravel cover is available around the screen during the packing of the casing pipe. The well is further developed with compressed air to remove any fine sand around the screen in the vicinity of the gravel pack.

Care must be taken in placement of gravel so as to avoid separation of coarse and graded particles of mixture. Failure to do so would result in the well continuously producing fine sand, though, proper gravel has been used in development. Constant sounding of gravel may be taken and fed till no more settlement takes place.

The following points may be observed:

- i) Size of the slotted pipe chosen should depend upon the size of the boring tube and the quantity of water required.
- ii) The assembly should be centred in the well. Extraction of boring tube is to be done slowly and without jerks so that the tubewell assembly is not dragged out with the boring tube.
- iii) The bottom of the assembly is kept closed with the bail hook at the bottom.

III) Reverse Circulation

The well assembly is lowered and gravel packing is done in a manner cited above as in case of rotary drilled wells. All such wells require minimum development but they give maximum sand free yield.

B) CONSTRUCTION OF WELLS IN HARD ROCKS

After levelling the drill at site, and completing all other arrangements, drilling is started with $5\frac{1}{8}$ inches (145 mm) diameter R.R. bit to drill through the top over-burden and loose weathered rocks. In case the hard rock starts from top itself the drill is started with hammer tool with cross bit at the very top of the hole.

The pilot hole is drilled till the hard compact formation is reached and then the same is reamed with $7\frac{3}{8}$ inches (200 mm) R.R. bit or 8 inches (203 mm) hole opener bit. The hole is thoroughly cleaned by blowing of air and 152 mm surface casing is pressed into position to prevent air leakage and caving of loose material into the well. In case, it is found that the top strata is much washed off, during drilling, the top casing is duly cemented after filling the cavity conditions. Sufficient care is taken that the casing is centered.

Once the hard rock is met, hammer tool with 152 mm bit, is lowered and drilling is continued. Cross bits are used for drilling

through soft and medium hard rocks while button bits are used in very hard and homogeneous rocks. At times, the formation may contain cavernous and loose zones, then the surface casing is extracted after drilling through that zone. The hole is reamed with 203 mm reamer bit. The blank casing is lowered to cover the problematic zone before the drilling is continued. The same procedure is adopted when it becomes necessary to shut off shallower aquifer zones, causing difficulty in drilling.

The main techniques involved in hard rock drilling are to maintain the optimum rotational speed and pull-down-pressures suitable for the rock being drilled, type of hammer bit used and the operational air pressure.

Hard rocks require slower rotation compared to softer rocks. The rotational speed of bits depends upon the air pressures and hammer blow frequency. Cross bits require slower rotation as compared to button bits. Pull-down pressures are to be adjusted within the permissible limits for the type of the hammer, depending upon hardness of rock. Hard formation need more pull-down pressures compared to softer formation. With addition of a new rod, as the drilling progresses, hydraulic pull-down pressures are to be reduced to compensate for the additional weight added. The speed range for the cross bits is from 12 to 25 rpm and 12 to 30 rpm in case of button bits. The permissible load on the bit, for 152 mm bit is of the range 453 to 1812 kg (1000 to 4000 lb). The actual rotational speed and pressure are to be decided by the feel of the driller on the drilling operation and keeping all other factors in mind. The excessive pressures and rotational speed may damage the bit while slow speed and pressure will result in wearing off the bits and reduction in penetration rate. All bits are kept ready duly graded and gaugewise, within the same nominal size. Higher gauge bits can be used initially and then lower gauge bits can be used subsequently. If the difference between the diameter of the bit and the hammer is less than 8 mm and even when the condition of the bit is good, it will cause damage to the hammer.

Data Collection During Drilling (Fig. 8.2)

The data on undermentioned parameters is collected while drilling is in progress to understand the lithology and water

bearing characteristics of the formation being drilled and also the water quality in them.

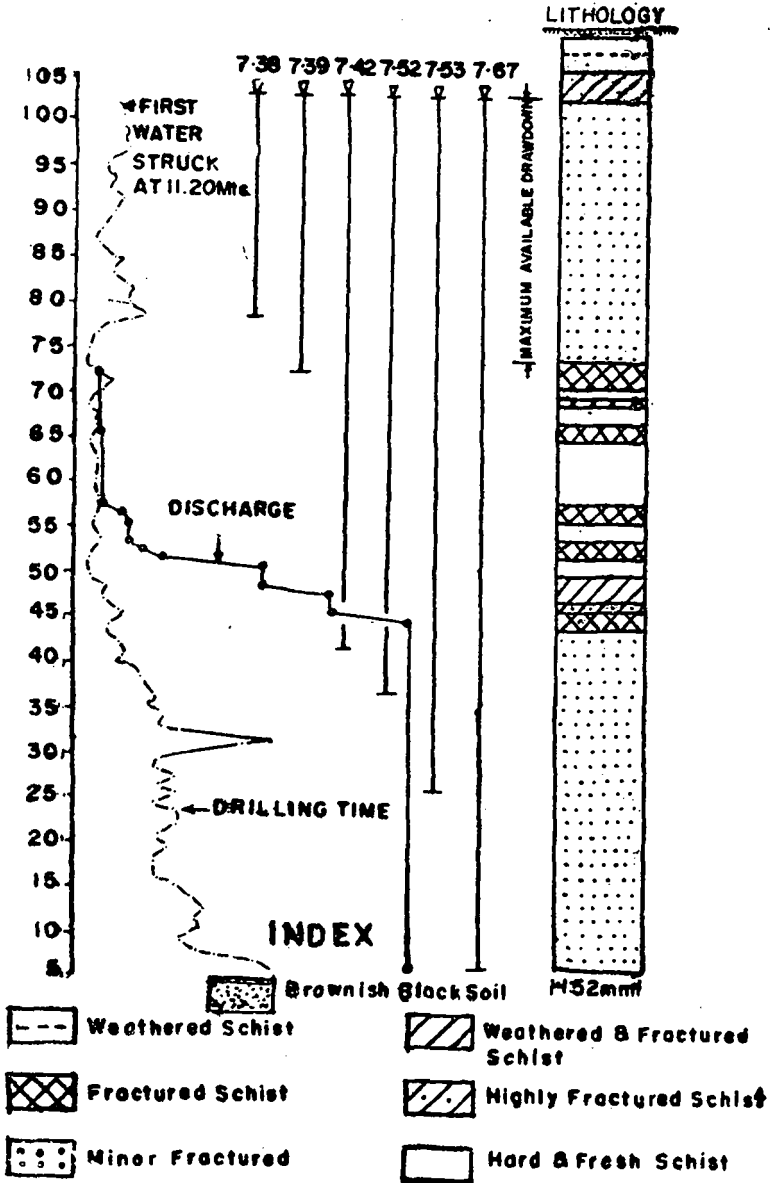

Fig. 8.2. Data Collection During Drilling

RATE OF DRILLING

Drill time log is maintained by noting the time taken for drilling each metre. This information is plotted graphically against depth which helps in delineating the changes in rock hardness and fractured patterns. A continuous watch is kept on the drill speed. Any unusual slow or fast movement, is recorded for subsequent interpretation. The mechanical and other factors contributing to the reduction in the rate of drilling may mislead in understanding the formational set-up. While noting the drilling time, care is taken to deduct the time spent in flushing of hole.

DISCHARGE MEASUREMENT

Return water from the well is measured frequently by using a precalibrated V-notch installed in the path of the return water or by container method. As no water other than the formation yield is contained in the return flow, this information helps not only in identifying the different water bearing zones but also knowing the incremental yield contributed by the respective zones. The measurements are taken after each metre of drilling or whenever there is any noticeable increase in discharge. For taking discharge measurements the drilling is stopped and air is blown continuously for a few minutes to allow the stored water to be pumped; thereafter discharge measurement is taken only when the flow is stabilised. This data is also plotted against depth on time log data sheet itself, so that information could be correlated with changes in drilling rate.

WATER QUALITY

Continuous watch on the quality of water is kept during drilling by taking frequent measurements of electrical conductivity with portable electrical bridge and pH values either with pH paper or pH meter.

Water samples are also collected for detailed analysis whenever any fresh zone is encountered.

LITHOLOGY

The rock cuttings come out in the form of angular chips and powder in this mode of drilling. Fresh samples coming from the hole are collected and preserved metrewise in polythene bags

after drying. A detailed study and examination of these samples, gives a clear-cut idea about lithological variation and nature of fractured zones. Before collecting the sample, the hammer is lifted off the bottom and full hole blowing is done to clear the well of any remains of previous cuttings. This is to get representative samples of the particular depth.

Tests Conducted During Drilling

To get quick appraisal of the various aquifer parameters, it is important and necessary to conduct some tests during drilling itself.

i) SLUG TEST

This is done to get some idea of the permeability characteristic of the upper zone. The drilling is stopped as soon as first water is struck and left for sometime for water level to stabilise. A measured quantity of water is introduced into the well and its dissipation is measured for 100 minutes. The data so collected is utilised to evaluate its permeability.

ii) INFLATABLE PACKER FOR INDIVIDUAL AQUIFER TEST IN SOFT SEDIMENTS AND HARD ROCKS (Fig. 8.3)

The Inflatable packer consists of the following:

1) Inflatable packer made of rubber in the shape of a double open neck jar with the neck inner diameter sufficient enough to fit on the pipe of required diameter (say 75 mm) and the middle about 125 mm diameter, when not inflated.

2) Two clamps just fit enough to hold the Packer at both ends to be tightened with nut and bolt.

3) A 3 mm diameter nozzle is fitted on the packer.

4) A long flexible plastic tube is fitted on the nozzle on the packer at one end, and other end fitted with a valve to let in and let out the pumped air.

5) A pump to inflate the packer from top and a pressure gauge to measure the pressure.

Procedure for Setting the Packer

1) The packer is fitted on the required diameter pipe and glued fast at both ends and tightened with clamp, nut and bolt.

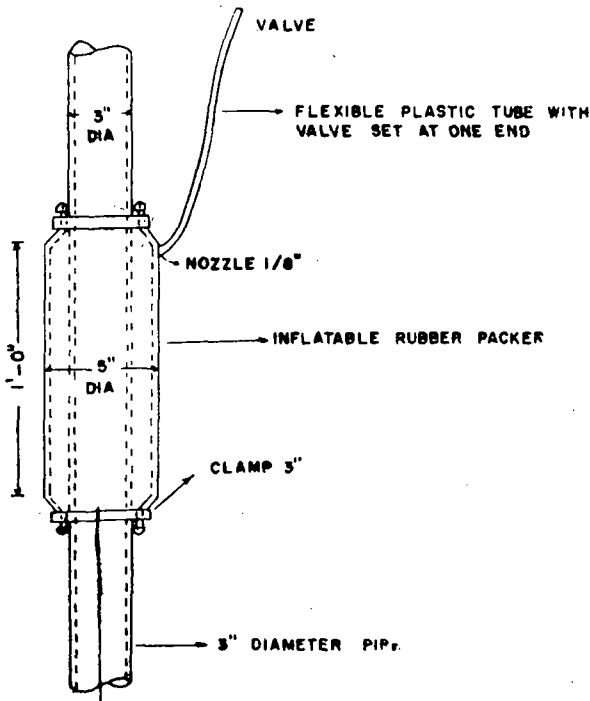

Fig. 8.3. Inflatable Packer for Well Test

2) It is tested at the surface itself to know the optimum pressure required for any leak before use. Then it is deflated.

3) It is lowered to the required depth along with the flexible plastic pipe which is attached to the nozzle.

4) Then it is inflated with a hand pump/compressor to the required pressure from the surface. When the packer is not required the air is let out at the top and the pipes pulled out.

h) Six Inch Packer for Conducting of Aquifer Test (Fig. 8.4)

Generally in a tubewell wherein three to four aquifer zones within the depth range of 50 to 100 metres are met, zonewise testing with a Packer test is required to be done by the compressor.

Improvised testing procedure was found out; two plates of 17.7×15.2 cm (7×6 inch) having in between pipe connections for 7.6 cm and 1.95 cm ($3/4$ inch) to be lowered side

by side duly welded. Suppose the first zone of 20 metres is to be tested, the hole would be reamed up to 20 metres with 20 cm (8 inch) bit size and then this arrangement of testing would be lowered inside the hole with 17.7 cm plate above and a packer resting at the collar of 20.3 cm and 15.2 cm. This would help to pump out the water, down from the aquifer and side by side the drawdown can be measured by 1.95 cm pipe (3/4 inch). This can be repeated for all three zones to be tested. This improvisation is necessitated for not having the pump of small discharge and so test was to be conducted with the compressor itself, for arriving at tentative discharge drawdown figures, which provide 90 per cent correct data. It could be further confirmed by testing with turbine pump.

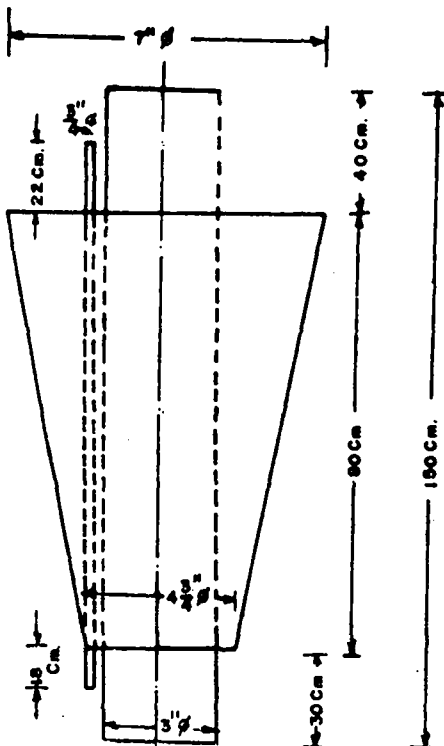

Fig. 8.4. Six Inch Packer for Conducting Aquifer Test

Air Test

A pump test with compressed air is conducted on completion of drilling. The drill string is withdrawn after drilling is completed and hammer tool taken out. The bare drill rods are kept one or two metres below the top of the main producing zone and air is blown out at constant pressure for a fixed time generally 100 minutes or 2 log cycles. During this period when the water is pumped out, the discharge is measured at frequent intervals. If there is any change, the average value is taken. It is not possible to take drawdown measurement but recuperation readings are taken for 100 minutes right from the first minute at varying intervals after shutting off air supply. The apparent transmissivity and optimum pumping rate are calculated. However the values and data so obtained are approximate as pumping conditions are rarely ideal.

Presence of Water

As the drilling is being done with air media the presence of water can be immediately felt and known as the hole gets drilled. The drilling in hard rocks is slow but with encountering of weathered portion of hard rocks the rate of drilling gets accelerated thus reconfirming the presence of water.

Size of Drill Cuttings

The size of drill cuttings would also be different while drilling in hard rocks or soft formations as compared to massive formations. The drill cuttings are also another pointer to the availability of water and could be confirmed by the grain size and variation of cuttings.

Comparing to Lithology

Actual drilling experience at site enables the driller to correlate the same with lithology of the drill hole with electrical logging when encountering water-bearing formation.

Design of Well—Positive and Negative Aquifer

For proper design of wells, Packer test for each aquifer zone is conducted separately. Yield is tested with compressor. The above tests would confirm whether zone is positive or negative, whether aquifer would charge the formations or would take

away the discharge from positive aquifer. In case of negative aquifer, the well is to be cased otherwise the discharge given by positive zone will be taken by the negative zone and the purpose of making the production well will be defeated.

Dropping of Drill Rods

The occurrence of cavities in limestone is initially deducted by sudden dropping of drill rods and later confirmed by separate type of electric log curve. This signals the importance of keeping a watch on the rate of drilling and depth. The drilling time is comparatively prolonged and warrants careful design and construction. Initially the clogging should be cleaned by adopting development with air compressor of high pressure so as to pull out the clay particles. A chemical treatment with sodium hexametaphosphate will quicken the process of removal of clogging. In this respect limestone depicts different pattern from the deccan trap formation where alternative sequence of weathered and compact horizon is noticed.

Highly Fractured and Fissured Zone

In case of Dadra Nagar Haveli wells, drilling has created certain problems in view of occurrence of highly fractured and fissured zones, the bore hole drilled at Naroli pierced such types of zones but recorded high yield of 617 lpm with the draw-down of 6.3 metres. The well could yield 22.5 kl/hr. During construction such zones have been identified by watching the rate of drilling with depth and providing the screen with gravel pack. This has prevented the entrance of clay and sediments in the well.

Identification of Zones

Identification of cavernous, solution channels in limestone and weathered vesicular zones in Deccan trap is a must for the construction of successful bore in the hard rocks.

Points to be Kept in View in Well Construction

- 1) The average depth of hole is 80 to 100 m. The average progress is 5 to 20 m/shift and the hole can be completed within three to four days after conducting air/pumping test.
- 2) The top hole is only cased due to over-burden and the

rest of the hole is naked with no assembly lowered.

3) At one of the sites Bhidi test well in district Wardha Maharashtra (Fig. 8.5) in Deccan trap when top loose formation was creating problems through caving and sloughing even making the drilling to proceed was a problem. The same portion was reamed with 8 inch (200 mm) bit. A 6 inch (150 mm) slotted pipe with iron plate at bottom was lowered. The annular space between 6 inch slotted pipe and a wall of hole above the collar of $7\frac{1}{2}$ inch steel plate was duly gravel packed. This served the dual purpose of making the hole drillable to the deeper depths and at the same time the discharge of the well which was meagre earlier, could be enhanced. This has been successful in Wardha

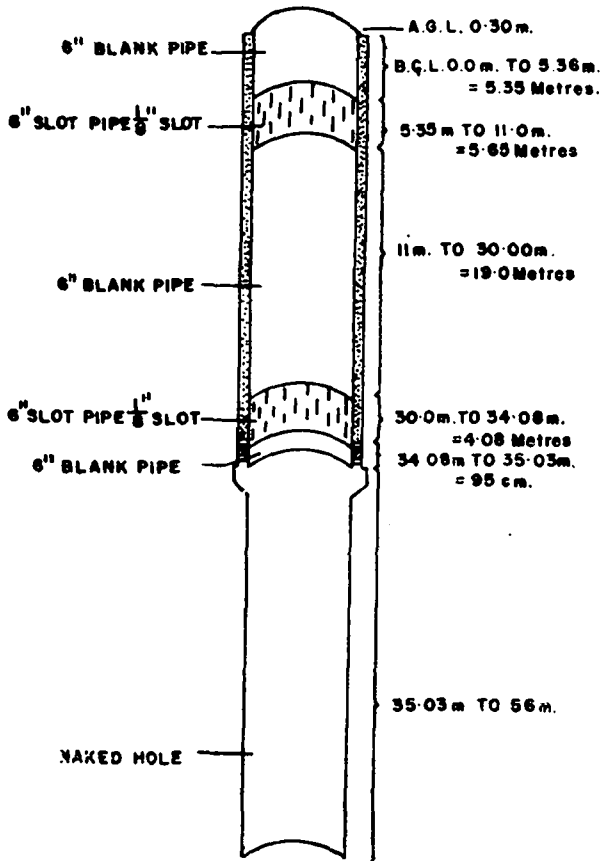

Fig. 8.5. Bhidi Test Well in District Wardha Maharashtra

area. This prevented the sloughing of well with red bowl clay and tremendous increase of discharge with moderate drawdown was noticed.

4) Different wells pose different problems. The rate of penetration is 30 minutes per metre in wheathered rocks and one to two hours in hard rocks. The depth of water level is given as 5 to 40 m. bgl. The potential aquifer zone was encountered at a depth of 10 to 70 m bgl, and encountering 3 to 4 m zones in cavernous fissured rocks. The yield from bore hole ranged from 30 lpm to 250 lpm with drawdown 2 to 28 m. In certain holes, the yield was less, the blasting was recommended and done. Five kilograms of gelatine was used in one of the sites. After blasting, the yield had increased to 80 lpm; while before the blasting it was almost negligible. This was done in Raipur area. Some times hydrochloric acid is added to open out the fissures and cavities. The same can be agitated with suitable means for one to two hours following which the well should be given blast of air until the water is relatively clear. It is seen that the discharge is enhanced. The yield of the well can be deducted while running the compressor to determine the extent of improvement in discharge. This method is repeated, if it is found that the expected results have not been achieved.

Fifteen to 30 lb of polyphosphate, i.e., sodium hexameta-phosphate is added in every 100 gallon of water. After pouring the same, surge plunger or jetting technique is used to agitate the well which helps to open out cavities/fissures. The recirculation of solution with high velocity jetting, can be instrumental in enhancing the discharge of well. Pump tests with air compressor were completed and no turbine or submersible pump was lowered when the discharge was meagre.

In limestone, only top formations are cased, rest of the hole is kept naked. It is seen that air being used for drilling is taken by the cavern and the drilling becomes problematic. In such cases, the lowering of casing is resorted to, so that the cavern portion is cased and drilling can progress. The hole drilled in limestone is given chemical treatment for increasing the discharge after removal of 6 inch casing. In case it is found that the discharge is meagre, due to clay formation, and other cementing material blasting of rocks is resorted to when all other alternative methods fail.

Gist in Construction of Wells in Hard Rocks

- 1) In hard rock well drilling no assembly is lowered except the top over-burden surface casing.
- 2) After completion of drilling and test a suitable well assembly is lowered in the portion where the formation is to be tapped.
- 3) Cement sealing can be done at the top of the bore well, if needed.
- 4) As the discharge from hard rock is through cavities, solution channels, the well is to be designed as per conditions at site.
- 5) If there is variation in water quality, selective tapping may be resorted to by eliminating unwanted saline zones. Saline zones at lower level present no problem as these can be back filled/set with cement. In case, when top zones are saline the blank pipe is lowered to that depth and annular space around the same is sealed.

INSTALLATION OF PIEZOMETER NEST

Piezometer or a cluster of tubes is a simple tube inserted into different zones in the same borehole for measuring the fluid potential levels of different flow systems (Fig. 8.6).

Welded G.I. pipe of 40 cm diameter is generally used for this purpose and up to four Piezometer tubes can be easily accommodated in a 150 cm well. The following procedure is adopted in the construction of Piezometer nest. In hard rock, this approach eliminates drilling individual observations wells; thus cutting down drilling costs.

Procedure for the Construction of a Piezometer Nest

- 1) Measure the water level.
- 2) Measure the total depth of the borehole before starting any installation work.
- 3) Decide on the depths of Piezometer.
- 4) Installation of Piezometer.

INSTALLATION AT THE BOTTOM OF THE HOLE

- 1) Add a small quantity of fine gravel or coarse sand to the bottom of the hole.

2) Measure the required lengths of piezometer pipes and a small margin of about 0.50 m so that the piezometer tubes will extend above ground level.

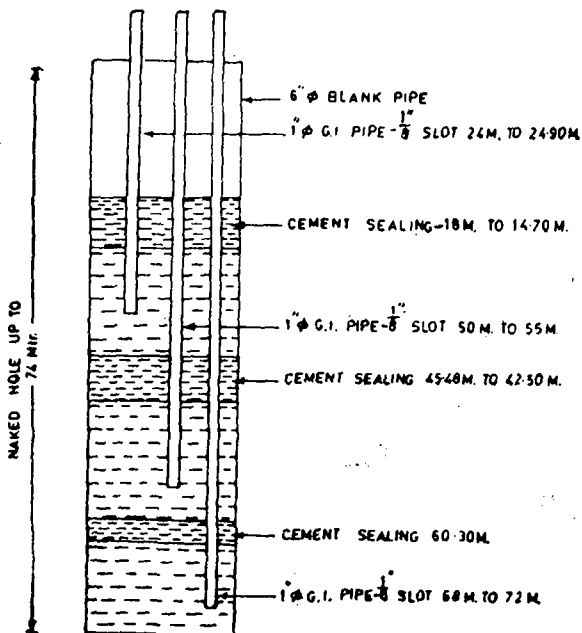

Fig. 8.6. Construction of Piezometer

3) Measure and note the lengths of the slotted portions of the pipes.

4) Construct the piezometer tube by welding the pipes "end-to-end" (the threads should be cut off). The slotted or open pipe is kept at the bottom of the piezometer tube. Care should be taken to see that the piezometer joints are welded water-tight. The pipe should stand on the bottom of the borehole and extend one half metre above the ground.

5) Add fine gravel until the borehole is filled to 0.5 metres approximately, above the slotted, lower end of the piezometer.

6) Sound and measure the hole, to make sure that the entire length of the slotted portion of the pipe is covered with gravel. Pack the gravel around the screen well by vibrating the pipe and by tamping the gravel filter with sounding rod. This

tamping is effected by dropping the sounding rod on the end of the sounding line several times.

7) After the gravel is well settled measure and note the depth at this point. This measurement is necessary for the calculation of the area of the hole which is open to the lower end of the piezometer tube; the calculated value is essential for analysing subsequent permeability tests in the piezometer.

8) Add little fine sand, to support the cement grout.

9) Fill up the piezometer tube with water and cap the pipe with plastic bag, to retain the water pressure. The water will slowly flow away into the aquifer. If the water is retained in the piezometer tube, the piezometer may be choked.

10) Instal the grout seal at this point and allow it to settle for some time.

INSTALLATION AT ANY DESIRED DEPTH (OTHER THAN THAT AT THE BOTTOM OF THE BORE HOLE) OR INSTALLATION OF OTHER PIEZOMETER

1) Sound and measure the depth of the borehole.

2) Backfill the borehole with coarse gravel to one metre below the proposed depth setting, i.e., if the proposed depth is 46 m, bring the gravel up to 47 metres. This margin of 1 m is required for the cement seal. While filling the hole, count the number of pails of gravel required as this indicates the presence of cavities in the hole at different depths.

3) Measure the required lengths (after cutting off threaded portion) of pipes keeping a margin of 0.50 m so as to keep the pipe above ground level. Measure and note the length of the slotted portion of the tube.

4) Install the pipes by welding face to face. Jointing should be perfect and there should not be any leakage. Keep the clamp at 0.50 m and allow the pipe to hang in the hole.

5) Add little fine sand to the bottom of the hole (as a seat for the grout).

6) Seal the bottom of the hole with cement grout. The grout can be added through the piezometer pipe so that it reaches the bottom of the hole directly, without mixing up with water in the borehole.

7) Backfill the hole with gravel to the depth at which the

piezometer is to be set. Sound and measure the hole and add more gravel, if necessary.

8) Connect the compressor to the piezometer pipe, lift the pipe to above 4 or 5 m and then develop the zone till the water is clear. While developing, the pipes can be gradually lowered.

9) Add a little sand to complete the settling of the grout.

10) Set in the piezometer at this point.

11) Add fine gravel to about one half metre above the slotted portion of the tube.

12) Pack the gravel well by vibrating the pipe and by tamping with the probe.

13) Add fine sand (seat for grout).

14) Fill up the piezometer tube with water and cap it with plastic bag and check up the working of the piezometer tube.

15) Sound the hole and measure the open area at this point and note.

16) Add grout and seal the zone at this point (this time the grout should not be added through this piezometer tube). It should be added from outside the tube. The whole process has to be repeated for installation of other such piezometers.

INSTALLATION OF WATERTABLE PIEZOMETER

The entire process of installation is the same as that of the other piezometers, except that in this case, no development is required and 3/4th of the entire length of watertable tubing has to be slotted.

1) The holes should be backfilled with gravel within one metre of the depth of the watertable well. Then, the bottom of the hole should be sealed as before. After the hole is cleared the watertable piezometer should be set.

2) Backfill the hole with gravel within 1 m of the ground surface.

3) Number all the piezometers, both on the individual caps as well as on the tubes leaving no scope for misplacements.

4) Enclose the entire nest (all the tubes) in 6 or 8 inch casing as a protective cover and fix it into the ground with a loose concrete mix.

5) Add the concrete mix inside to ensure that no water leaks into the borehole.

6) Give the depth of setting of different piezometers and

watertable on the casing pipe so that any visitor can observe the setting on the spot; cap up the casing. Scientific construction of piezometers by employing appropriate techniques is therefore, highly essential to ensure precise reflection of the behaviour of ground water system(s).

Well Development Methods

Introduction

Water well development has gained much significance and importance in Groundwater Exploration Programme in India for ensuring the availability of sand-free water and adequate discharge to meet all our water demands in the country.

In this context, it has become very important that development techniques may be applied judiciously with expertise and know-how available to achieve the optimum results.

This chapter deals with the methods and techniques of water-well development such as

- 1) Dispersal techniques
- 2) Concentration techniques
- 3) Stimulation techniques

The various recommendations with regard to methods suitable for well development under various geological conditions, have been made.

'Hydraulic fracturing' is proposed to be adopted as an ideal method for developing hard rock wells since it has the advantage of opening and enlarging the fracture system of rocks. This method has the additional advantage of revitalising the sick wells as well.

Adoption of appropriate well development methods would increase well efficiency. This would also make the well cost effective.

Water-well development has gained much significance and importance for ensuring sand-free and adequate discharge at optimum drawdown. A number of wells are to be drilled either through percussion, rotary and combination drills in alluvial/

semi-consolidated and by Down-the-Tool Hammer drills for drilling in hard rock areas. Development of such wells need different techniques depending on the field conditions at site so that sand-free water could be developed and extracted for the use. After a well is properly constructed and gravel packed its development is taken up immediately.

Methods and Techniques of Water Well Development

Correct methods are essential to well development. Well development techniques are divided into three types:

- a) Dispersal techniques
- b) Concentration techniques
- c) Stimulation techniques.

a) DISPERSAL TECHNIQUES

In this method, the development force is allowed to act on the entire length of screen at one time. Dispersion techniques are rather made difficult by the long screened deep wells. The methods such as surging, over pumping, back washing tend to distribute the force over the entire area of screen length. If the screen length is 30 m large or more, insufficient force is available over the screen to remove much of the mud cake. It has been experienced that well efficiency over 30 per cent is not achieved by the dispersion method of development.

Surging Tool

With the use of surging tool piston type movement is worked in top length of housing assembly at very slow speed. The diameter of the piston is less than the diameter of top housing diameter. The same is done through a surge block as above. The movement through the formation, gives surging effect to the formation being treated. This could be done with or without chemicals. These methods become instrumental in flushing out sand, clay and finer materials which reduce the permeability of formations. Surging should only be done at very low pace; thus developing of aquifer is done at greater and greater depths. The construction of surging tool can be done at site itself by placing synthetic rubber pads between two steel plates, duly bolted and then joined to drill pipe connection for working with the drill for its up and down movement.

Over Pumping

1) Over pumping is pumping at maximum drawdown. This method is not effective as it encourages bridging due to the flow in one direction.

2) The pump consists in starting and stopping the pump intermittently to produce rapid changes in the head.

3) The pump is run to produce maximum drawdown and then stopped at short intervals as it has the effect of back wash through water in the pump column.

4) The pump is run to the maximum capacity until it produces maximum drawdown.

Back Washing

Water under pressure is forced into the formations and carries with it the clogged sand particles. The operation of back washing may be followed by bailing and then re-pumping is done till the well is fully developed and water is clear.

Air Lift Development

i) The compressor of adequate cfm capacity and pressure (350 cfm and 100 pounds per sq inch for shallow wells and 500 to 600 cfm and 250 psi for the deeper wells) are utilised. Compressed air is injected through air line of 1 in. directly through perforated foot piece in drop pipe (education line of 4 in.) in 6 to 8 in. or 8 to 12 in. well assembly due to water getting lighter in weight than outside differential head. Such working of air line as at different depths is continued against the different aquifer zones from top to bottom and vice-versa for number of times till the discharge becomes sand-free and constant. Usually a compressor should run for 60/80 hours. Discharge is pulsating type and a rough estimate of discharge should be made out.

ii) Back washing should be done by stopping the discharge at random through 3-way valve intermittently and this back pushed water would move into the formations to clear it of any sand infiltration.

b) CONCENTRATION TECHNIQUES

The second family of development is concentration techniques. These are methods of choice in a deep long screen water levels. The types most commonly and successfully employed are:

- 1) Contained air lifting.
- 2) High velocity jetting.

1) *Contained Air Lifting* (Fig. 9:1)

Contained air lifting is done between packers. On the surface, the eductor is fitted with valve so that the pressure can be alternatively applied and released in a chosen way. The tool isolates 1 to 3 m of the screen and concentrates the full force of air lift to the desired depth.

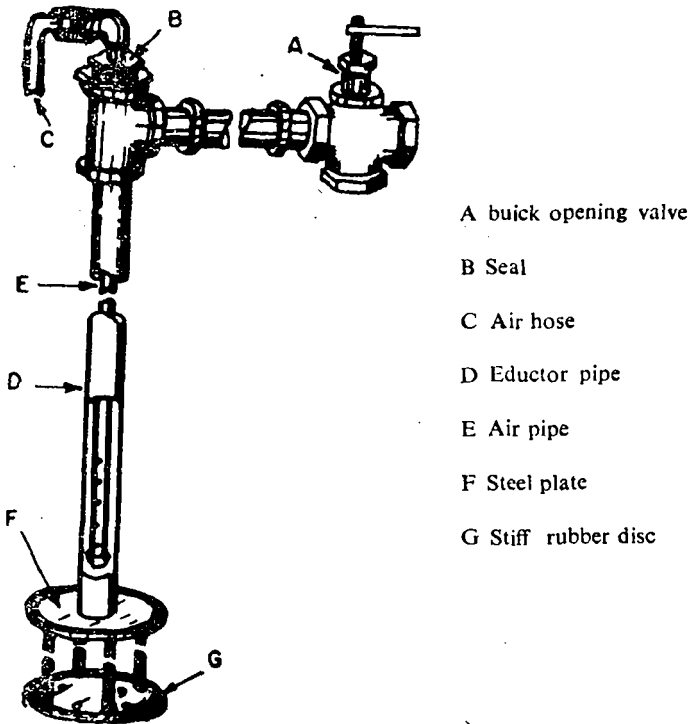

Fig. 9.1. Contained Air Lifting Apparatus

The following two procedures are recommended.

- i) The operation should begin at the bottom of the screened zone to move upward slowly.
- ii) Measure specific capacity of each well zone, being developed to monitor the degree of development. The zone is taken as developed when specific capacity is observed stabilised.

High Velocity Jetting Tool

Sometimes it is seen that well is not giving adequate discharge even when all precautions for its construction have been completed in conventional rotary drilled well. This situation might have arisen due to the mud cake wall deposit not having been properly removed. Such horizontal jetting at high velocity against the effective zones would wash the formation through flow screen opening increasing the well-yield and reducing draw-down. The jetting should be done with jetting tools with reciprocating type of pump fitted on the drill. This would agitate the sand and gravel particle around the screen bringing the finer ones inside the body of the well assembly itself. The same could be further alternatively cleaned with air lift as given under air lift. The jetting tools could be locally made. It is to be done with care and tact, so that at no stage screen/slotting pipe is damaged, nor it should work over the extent desired and needed. Thus fine sand, clay would be washed off the formation giving clear discharge from the well (Fig. 9.2).

Simultaneous jetting and airlifting: Sometimes in pumping water through formation, jetting and air lift development is done simultaneously. It is seen that these methods have been implemented in enhancing the discharge of 20000 litres to 70000 litres/hours. This method has been tried recently in one of the wells drilled for Government press at Faridabad.

c) STIMULATION TECHNIQUES

These techniques do the following:

- i) Open/enlarge fractures in igneous, metamorphic and basaltic rocks.
- ii) Increase well yield.

A dry well located in crystalline rock such as granites can be converted into production well by employing stimulation techniques (Fig. 9.3a).

Stimulation techniques include the following:

- 1) Brushing,
- 2) Acidising,
- 3) Chemical treatment,
- 4) Shooting, and
- 5) Hydraulic fracturing.

WORKING OF SURGE PLUNGER IN CASING

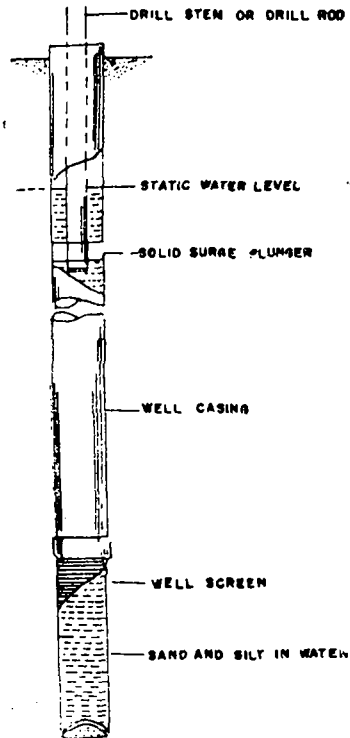

SURGING WITH AIR

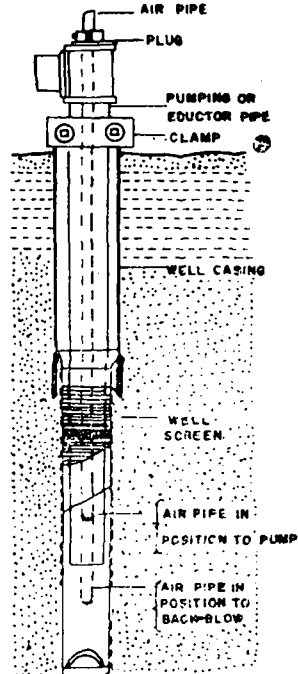

JETTING ACTION

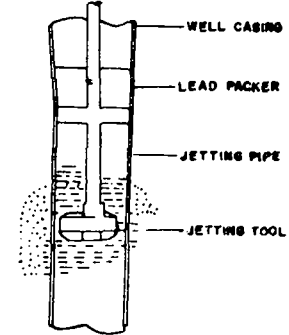

Fig. 9.2. Chart for Well Development Technique

1) *Brushing*

It involves mechanically washing with an oversize wire brush assembly and jetting the walls with high velocity water. Steel brushes are joined to the drill pipe so that it would work against the clogged portion of slotted pipe. It will result in stimulation of discharge. Use of chemical additive can also be done.

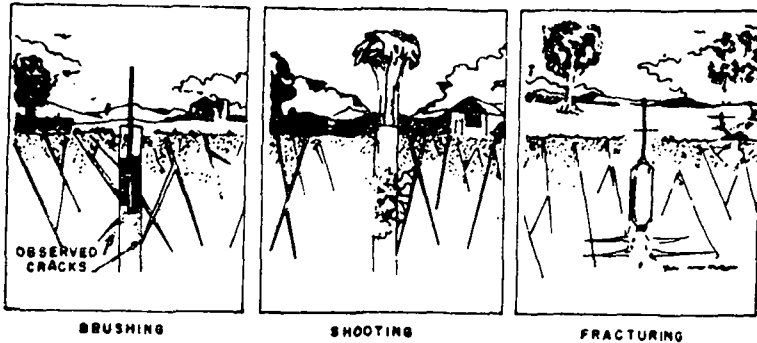

Fig. 9.3 a. Stimulation Technique

2) *Acidising*

Acidising is an accepted method of water-well stimulation. This increases the water-well production from a well. The soluble parts of formation are dissolved and these permit higher rate of water to these bore wells. Fifteen per cent of hydrochloric acid is used in about 500 to 20,000 litres of water. Acid is introduced through a temporary tubing extending to a position nearer the bottom of the well and the solution is allowed to rest for half an hour to four days. The pump is lowered again. The spent acid is pumped out of the hole in four to eight hours.

Acid introduced tends to flow into and widen the fractures leading into the bore wells and also acid reacts with the drill cutting. It would afford the following advantages.

- i) Immediate production is increased.
- ii) It becomes rapid and inexpensive method.
- iii) It minimises lifting cost. For maximum success in acidising, all relevant data should be studied and evaluated.

3) *Chemical Treatment*

Dispersing agents are added to the drilling fluid to backwash

or jetting water to counteract the tendency of mud to stick to sand grains. Sodium hexametaphosphate is the best. It is added at the rate of half pound of phosphate to 100 gal of water and allowed to stand one hour before starting development operations.

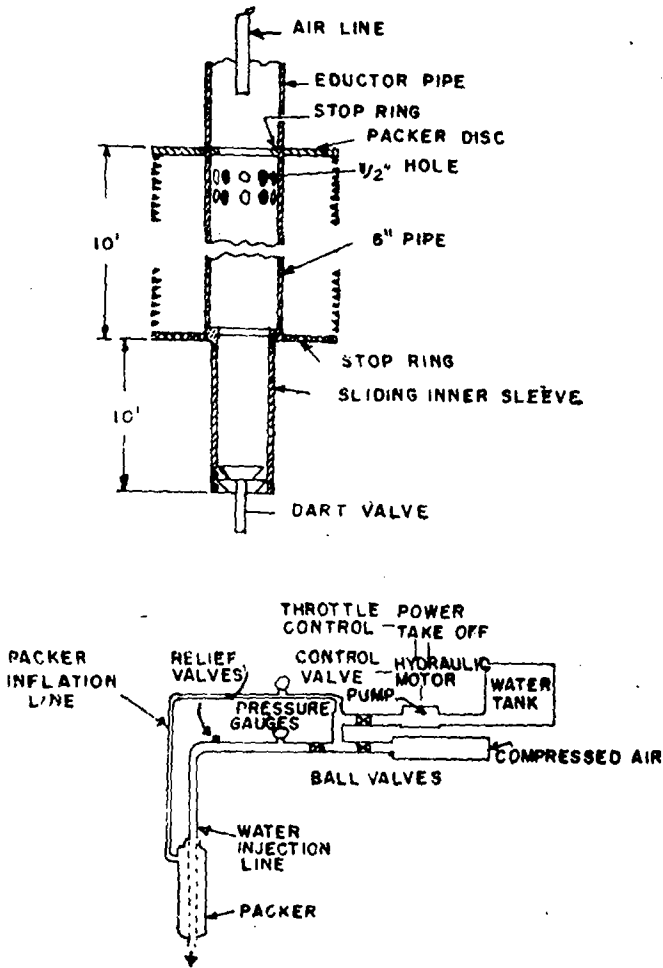

Fig. 9.3 b. Combination Tool and Hydro-fracture Equipment

4) Shooting

It involves shooting the well with explosive detonators. This action develops local fractures around a borehole it causes agit-

ing action which loosens the drill cutting. Shooting in rock areas and in open hole/naked hole where the discharge is meagre the resorting to shooting is done to enhance the well yield.

This involves blasting through massive detonating charges of explosive in the form of dynamite and nitroglycerine. This has been done successfully while trying to enhance the discharges in wells drilled in limestone formations of Raipur, Bilaspur areas of M.P.

HYDRAULIC FRACTURING (Fig. 9.3 b)

It opens up the rock fractures which improve well yield. It consists of injecting liquid water into well under high pressure so that formation is actually parted or fractured. In hard rock areas where the discharge is found inadequate due to lack of water bearing cracks and fissures the hydraulic fracture can be attempted. This method is very much superior to blasting. A rubber sleeve is usually placed in the drill hole below the casing at 15 m or desired depth level from the surface and water is pumped in hole with a pressure of 50 to 55 kp/cm². Pressure is connected and disconnected as and when needed. This pressure in the production zone causes small fractures to expand. These newly opened fractures provide effective inter-connection between nearby water bearing fracture and well bore. The very high pressure being pumped expands the small tight fracture. At the release of the pressure the formation takes the original shape and the water is passed out to the bore well. A hydraulic fracturing is not possible if there are no small cracks originally. This method has additional advantage of revitalising the sick well.

Whatever the drilling techniques the choice of the tools will appreciably optimise well development efficiency and costs. No development could be considered as complete unless discharge of well before the test and after development have been plotted in graphical form to know the extent of improvement. It is a must and the most desirable method.

The discussion of the well development methods and ideal techniques are tabulated in Table 9.1.

Recommendations

It would be seem that different formations need adoption of

different development techniques and methods. Application of appropriate development techniques would achieve cost effective optimum well efficiencies.

Table 9.1. Ideal Well Development Methods

<i>Formation</i>	<i>Type of drilling</i>	<i>Type of tool</i>	<i>Ideal techniques for well development</i>
Unconsolidated	Percussion combination drill	Air lift over pumping, back washing, brushing	Over pumping, air lifting, bailing
Semi-consolidated	Rotary	Surging, back washing, jetting, brushing, air lifting	Back washing, jetting, surging, air lifting
Hard rock	DTH	Acidising, shooting, chemical treatment, hydraulic fracturing	Hydraulic fracturing is most effective and ideal

Thus the recommendations are as follows:

- 1) Well development methods like air lifting, pumping are to be used in normal cases.
- 2) Surging, air lift and high velocity jetting is to be used where there is bridging of gravel or mud cake in the way of development.
- 3) Acidising, blasting and chemical treatment and hydraulic fracturing are to be used where the discharge are meagre and needs stimulation to boost well production.
- 4) Hydraulic fracturing should also be used for rejuvenating sick wells.

These methods if properly done at the right time would not only ensure sand-free and constant discharge from bore wells at optimum drawdown but would also prove to be economically feasible, technically sound and successful to usher improvement in the quality of groundwater exploration in India. So, always use the right method with right type of tool in appropriate formation.

Ground Water Hydraulics

A very cryptic style has been adopted in describing ground water hydraulics where emphasis is laid more on the practical aspects rather than on theoretical aspects. Among the frequent concepts used in hydraulics are specific storage, hydraulic head and fluid pressure. Only the physical significance of these concepts has been described here.

i) The porosity of pervious sand bed is defined as the ratio of volume of pores space in the rock to the total volume of rock material. At once a question comes to mind about what volume of non-saturated or solid substance is present in a rock of 1 cu.m if its porosity is 0.30?

ii) Similarly what amount of water is present in 1 cu.m of porous aquifer if the porosity is 0.30 and per cent saturation of pore spaces is 20 per cent?

iii) Fluid pressure is force per unit area. Dimensionally this is potential energy per unit area.

iv) Looking at the Fig. 10.1 it may be seen that the expression $h_p + z$ gives energy of a unit weight of water located in the surroundings of a point 'O'.

v) Darcy's law states the relation of specific discharge per unit area to the gradient of hydraulic head. It gives the steady state flow in porous well section.

Based on Darcy's Law, one has to identify the behaviour of ground water flow as follows:

a) Whether ground water flows from higher elevation to

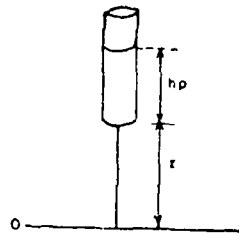

Fig. 10.1 Piezometer

lower elevation?

b) Whether ground water flows in the direction of decreasing pressure?

c) Whether ground water moves in the direction of decreasing head?

It may be noted that statement (c) gives ground water movement.

Darcy's Equation

Situation in aquifer is representable by Darcy's Law which has the form,

$$q_x = -k_x \frac{dh}{dx}$$

$$q_y = -k_y \frac{dh}{dy}$$

$$q_z = -k_z \frac{dh}{dz}$$

Where k_x , k_y , k_z are hydraulic conductivities in x , y and z directions.

Most commonly it is seen that stratified sedimentary formations in which hydraulic conductivity is normal to bedding is less than that parallel to the bedding. If bedding is horizontal, or subhorizontal, Darcy's law is applicable using $k_x = k_y$.

Example: Supposing an observation well is located in confined aquifer. By measurements in this well we find a linear increase in head with some distance from the stream which cuts the aquifer. In this case which of the following would be true:

- i) There is flow within the aquifer.
- ii) Steady flow through the aquifer into the stream takes place.
- iii) A flow which increases specific discharge as one approaches the stream occurs in the aquifer.

It may be concluded that statement (ii) is correct.

Many questions can be put based on Darcy's Law. Assume that outflow differs from inflow and the hydraulic conductivity (k) and aquifer thickness are constant. In this case which is considered applicable:

- i) The water level in the aquifer must rise.
- ii) Hydraulic gradient at outflow face of aquifer differs

from that at inflow face.

iii) The water withdrawal rate from ground water storage must be given by Darcy's Law.

The statement (ii) above is applicable. From this it emerges that at outflow face we apply Darcy's Law as under:

$$Q_2 = -kb \Delta y (dh/dx)_2$$

and at inflow face of the aquifer.

$$Q_1 = -kb \Delta y (dh/dx)_1$$

It emerges that hydraulic gradients $(dh/dx)_2$ and $(dh/dx)_1$ would also change.

Well Test and Drill Stem Test

WELL TEST

An ideal Well Test consists of three parts:

- a) A constant—discharge test.
- b) A recovery test.
- c) A step drawdown test.

The following points shall be kept in mind.

1) Prior to the commencement of a well test, water levels in the test well are measured for a long time.

2) Pump is then started and operated for three to five hours at a constant rate and water levels are measured at pre-defined intervals.

3) Pump is stopped at the end of constant rate portion of the test; recovery recordings are taken.

4) Step drawdown test is carried out at the end of recovery test.

5) Pump is turned on at constant fraction of pumping rate and water level are taken as earlier.

6) Pumpage is increased and water levels are measured for 15 minutes; the procedure is repeated.

Water level are taken according to the following frequency.

<i>Time in minutes</i>	<i>Periodicity of measurements (minutes)</i>
0-10	1
10-20	2
20-60	5

60-100	10
100-180	20
180-300	30
Over 300	60

Besides above the following is also a reasonable standard for measurement intervals.

- a) Every 1 hour until completion of 18 hours.
- b) Every 2 hours until completion of 100 hours.
- c) Every 4 hours until completion of test.

During a well test, always collect water samples and take water temperature measurements.

Aquifer Test

Aquifer test is always in three steps for three distinct objectives.

<i>Stage</i>	<i>Purpose</i>
<i>First stage:</i> It is a completion test.	To obtain yield drawdown relationship.
<i>Second stage:</i> Well is pumped in steps and at least three steps are taken.	To estimate well efficiency (by Rorabaugh Method, 1953).
<i>Third stage:</i> A constant rate test.	To obtain aquifer parameters such as transmissivity (T) and storativity (S).

TEST WELL LAYOUT

Transmissivity (T) is evaluated from test well data without aid of observation well, while coefficient of storage (S) is estimated with use of observation wells.

In a homogeneous formation only one observation well is sufficient. In aquifers where anisotropic conditions prevail many observation wells are required. Customary three observa-

tion wells are good enough for accurate estimates. Two observation wells should be on one side of the another well having alignment down the hydraulic gradient. In case of a hard rock aquifer, it should be along the prominent fractures or joint directions. The third observation well could be along a line of the test well drawn at a right angle from the first observation well.

For achieving accurate results, it is essential that an observation well should be drilled to the same aquifer level as main well.

Ideal distance for the observation wells are as follows.

<i>Type of aquifer with T value</i>	<i>Distance to observation well</i>
1) Water table aquifer with low transmissivity (<i>T</i>).	30-35 m
2) Water table aquifer with high transmissivity (<i>T</i>).	40-65 m
3) Semi-unconfined aquifer.	30-50 m
4) Semi-unconfined aquifer—high <i>T</i> .	50-65 m
5) Semi-confined aquifer—low <i>T</i> .	65-125 m
6) Semi-confined aquifer—high <i>T</i> .	65-125 m
7) Confined aquifer—low <i>T</i> .	65-125 m
8) Confined aquifer—high <i>T</i> .	125-200 m

The period of test pumping is as follows:

1) Completion test and step test.	Not less than 20 hours.
2) Confined aquifer without barrier boundary.	A constant rate test of few hours.
3) Unconfined aquifer for delayed yield.	Over 20 days.
4) For confined and semi-confined aquifers.	2 to 7 days.

Test data is recorded in a properly desired format as shown below.

Format for recording well test data.

Well No.....

Code No.....

PUMPING TEST DATA

1. NAME OF THE PROJECT
 2. LOCATION OF SITE : District.....Taluk/Tehsil.....
Village.....Survey No.....
Coordinates.....Toposheet No.....
 3. WELL DETAILS : Pumped well.....Observation wells....
.....Distance and bearing from pumped
well to observation wells.....
 4. DATA OF PUMPED WELL/OBSERVATION WELL.....
(a) Measuring point.....(m) Height a.g.l.....(m) Altitude
(b) Method of discharge measurement.....
(c) Water level measurement by tape/.....
- NOTE (i) Under remarks give temperature of water and indicate collection of water sample, turbidity, etc.
(ii) Recovery measurements should be continued till near pre-pumping level is reached.

Measured by	Date	Hour	Tape		Depth to water below measuring point (m)	Q (LPM)	Remarks
			Reading at Measuring point (m)	Water level (m)			
1	2	3	4	5	6	7	8

METHODS OF ANALYSING PUMPING TEST DATA

An analysis of a test data has the following assumptions.

- The aquifer should have infinite areal extension.
- The aquifer should be homogeneous, isotropic and uniform in thickness.
- Prior to pumping the water, surface should be nearly horizontal.
- Should have constant rate discharge.
- The well should penetrate the full thickness of the aquifer.

Confined aquifer—steady-state flow: For analysis of draw-down data of a confined aquifer. Theim's method is ideal.

Theim's methods: The test should satisfy the following conditions:

- That the aquifer is confined.
- That flow to the well is in steady-state situation.
- Theim (1906) observed that for an aquifer with the above conditions, the well discharge can be expressed by the aquifer.

$$Q = \frac{2 \pi T (S_1 - S_2)}{I_n (r_2/r_1)} \quad \dots(1)$$

where Q = discharge in M^3/day ; T = transmissivity of aquifer in M^2/day ; r_1 and r_2 = the respective distances to the piezometers from test well in metre; and S_1 and S_2 = the respective drawdowns in the piezometer in metres.

The above equation can be written as

$$T = \frac{Q}{2\pi(S_1 - S_2)} I_n \frac{r_2}{r_1} \quad \dots(2)$$

Unsteady state flow: C.V. Theis (1935) developed a non-steady-state formula which conceptualised the time factor and the storage coefficient. This equation was derived from the analogy between the flow of ground water and the conduction of head.

It is written in the form

$$S = \frac{Q}{4\pi T} \int_u^\infty \frac{e^{-u}}{u} du$$

$$= \frac{Q}{4\pi T} W(u) \quad \dots(3)$$

$$\text{where } u = \frac{r^2 S}{4 T t} \quad \dots(4)$$

s = the drawdown in metres in a piezometer; r = distance to piezometer (in metres); Q = the constant rate discharge in M^3/day ; S = storage coefficient; T = the transmissivity in M^2/day ; t = the time in days since pumping started; and $w(u)$ = is read as "well function" of u .

$$-0.5772 - I_n u + u - \frac{u^2}{2.2!} + \frac{u^3}{3.3!} - \frac{u^4}{4.4!}$$

The values of $W(u)$ as u are available in the form of a table, in any standard textbook on ground water hydrology.

The following conditions should normally be satisfied, besides those listed earlier.

- The aquifer should be confined.
- The flow to the well should be in unsteady state.
- The water removed from the storage is discharged instantaneously with decline of head.

Theis devised a convenient graphical method of superposition for solving Eqs. (3) and (4) which can be rearranged as:

$$\text{Log } s = \left(\log \frac{Q}{4\pi T} \right) + \log W(u) \quad \dots(5)$$

$$\text{Log } r^2 = \left(\log \frac{4T}{S} \right) + \log u \quad \dots(6)$$

Procedure: Prepare a Theis type curve on a double logarithm paper by plotting values of $W(u)$ against $1/u$. Plot the values s against t/r^2 or t on another sheet of the same scale as that used for the type curve. Place the field data plot over the type curve and keeping the coordinates of both data plot and type curve parallel, locate the position of best match between the data plot and the type curve. Select an arbitrary match point 'A' on the overlapping portion of the two sheets of graph paper and determine the coordinates $W(u)$, $1/u$, s and t/r^2 or t . Substituting Q and these values in equations (3) and (4) lead to the determination of aquifers parameters.

$$T = \frac{Q}{4\pi s} W(u) \quad \dots(7)$$

$$\text{and } S = \frac{4Ttu}{r^2} \quad \dots(8)$$

DISCHARGE RATE MEASUREMENTS

To avoid complicated calculations in analysis of an aquifer test data, it is necessary to keep the discharge rate constant throughout the test. Measurement of discharge is done in several ways, the circular orifice being the most common method used to measure the rate of discharge from a turbine or a centrifugal pump.

TESTING OF THE YIELD OF WELLS

- 1) The rough yield can be measured by rapid bailing.
- 2) The yield of well may be measured by allowing the water to pass over the right angle V-notch (16 gauge). Then reading of discharge corresponding to mark on V-notch gives the discharge measurements. V-notch provides constant method of discharge of 120 to 7200 litre/minute. The same consists of right angle notch with sharp edges cut from plate fitted at the outlet of a tank (Table 11.1).
- 3) The yield can be measured by circular orifice plate method. An orifice plate of 3 inch (75 mm) is fixed. Then connection inside the end of a 4 inch (100 mm) pipe is provided to measure the (manometer) head of water raised through manometer connection tube 1/8 inch (3 mm).

$$Q = Cd \frac{\pi d^2}{4} \sqrt{2gh}$$

where Q =discharge in m^3/sec ; d =diameter of the orifice in m; h =Piezometric head in m; Cd =coefficient of discharge.

This depends on the ratio of $\frac{\text{orifice diameter}}{\text{pipe diameter}}$

The orifice is a perfectly round hole in the centre of a circular steel plate that is fastened to the outer end of a discharge pipe. A piezometer tube is fitted in a 1/8 inch (3 mm) or 1/4 inch (6 mm) hole made in the discharge pipe exactly 61 cms from the orifice plate. The water level in the piezometer represents the pressure in the discharge pipe when water is pumped through the orifice. Standard tables (Johnson 1966) have been published which show the flow rate for various combinations of orifice and pipe diameter (Table 11.2).

- 1) Sketch of orifice meter (Fig. 11.1).
- 2) Sketch of 'V' notch (Fig. 11.2 Appended).
- 3) Tables 'V' notch (Table 11.1).
- 4) Tables orifice meter (Table 11.2).
- 5) Tables for water standards (Tables 11.3 and 11.4).

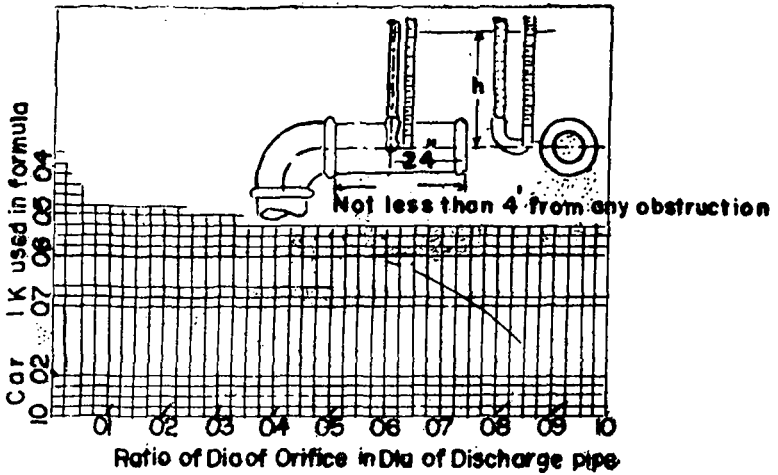

ORIFICE METHOD

$$R = \frac{\text{Dia of orifice in inches}}{\text{Dia of Discharge pipe}}$$

$$G = KAV^2gh = KA = 8.025 V\sqrt{h}$$

A = Area of Orifice in sq inches.

h = Height of water in glass above Centre of pipe in inches.

Fig. 11.1. Sketch of Orifice Method

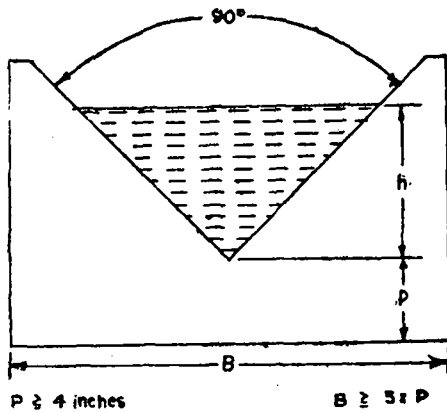

Fig. 11.2. Sketch of 'V' Notch

Table 11.1. Discharge of 'V' Notch Tables

<i>H</i> , <i>mm</i>	Litres/ minute	Cubic metres/hour	<i>H</i> , <i>mm</i>	Litres/ minute	Cubic metres/hour
1	2	3	1	2	3
75	134.12	8.05	230	2135.82	128.15
80	157.30	9.44	235	2252.34	135.14
85	182.71	10.96	240	2372.52	142.35
90	210.41	12.62	245	2496.54	149.79
95	240.47	14.43	250	2624.22	157.45
100	272.95	16.38	255	2755.74	165.34
105	307.91	18.48	260	2891.16	173.46
110	345.40	20.72	265	3030.54	181.83
115	385.50	23.13	270	3173.58	190.41
120	428.21	25.68	275	3320.76	199.25
125	473.65	28.42	280	3472.02	208.32
130	521.82	31.31	285	3626.94	217.61
135	572.81	34.37	290	3786.36	227.18
140	626.64	37.60	295	3949.62	236.97
145	683.40	41.00	300	4117.02	247.02
150	743.10	44.58	305	4288.62	257.31
155	805.74	48.35	310	4464.30	267.86
160	871.50	52.29	315	4644.30	278.66
165	940.32	56.42	320	4828.50	289.70
170	1012.56	60.74	325	5016.84	301.01
175	1087.44	65.25	330	5209.68	312.58
180	1165.80	69.94	335	5406.84	324.41
185	1247.40	74.84	340	5608.56	336.51
190	1332.30	79.94	345	5814.48	348.87
195	1420.56	85.23	350	6024.60	361.48
200	1512.30	90.74	355	6239.40	374.37
205	1607.40	96.44	360	6459.00	387.53
210	1705.98	102.30	365	6682.80	400.96
215	1808.10	108.48	370	6910.80	414.66
220	1913.70	114.82	375	7114.20	428.64
225	2022.90	121.37	380	7381.80	442.89

DRILL—STEM TEST

The procedure for Individual Aquifer Zone Testing is described below.

To have a quantitative and qualitative assessment of ground water, exploratory boreholes were drilled by Direct Rotary Frank rig and individual aquifer tests were conducted to establish the relative piezometric heads of independent horizon besides knowing the approximate discharge and drawdowns.

Table 11.2. Orifice Tables

Head in inches
Discharge in USGPM

1 inch = 25.4 mm
1 USGPM = 3.785 LPM
LPM = 5.43 M³/day

(Discharge in USGPM)

Head in inches	3" Orifice		4" Orifice		5" Orifice		6" Orifice		7" Orifice	8" Orifice	Head in inches
	4 in pipe	6 in pipe	6 in pipe	8 in pipe	6 in pipe	8 in pipe	8 in pipe	10 in pipe	10 in pipe	10 in pipe	
1	2	3	4	5	6	7	8	9	10	11	12
5	100	76	145	140	280	220	380	320	—	—	5
5.5	104	79	153	145	293	230	394	333	—	—	5.5
6	108	82	160	150	305	240	408	345	—	—	6
6.5	111	85	167	155	316	250	421	358	—	—	6.5
7	115	88	172	160	328	260	433	370	—	—	7
7.5	119	91	179	165	339	270	446	383	—	—	7.5
8	122	94	185	170	350	280	458	395	600	935	8
8.5	125	96	190	175	361	289	471	408	617	963	8.5
9	128	99	195	180	372	298	483	420	633	992	9
9.5	130	102	200	185	383	307	495	433	650	1016	9.5
10	133	104	205	190	393	316	508	445	666	1040	10
10.5	137	107	210	195	402	324	521	458	682	1060	10.5
11	140	109	215	200	412	330	533	470	698	1080	11
11.5	143	111	220	204	421	338	545	480	713	1100	11.5

Table 11.2 (Contd.)

1	2	3	4	5	6	7	8	9	10	11	12
12	146	114	225	208	430	346	556	490	728	1120	12
12.5	149	116	230	212	439	354	567	500	743	1139	12.5
13	151	118	234	216	448	362	578	510	757	1158	13
13.5	154	121	239	219	457	369	589	520	771	1176	13.5
14	157	123	243	224	465	376	599	530	785	1194	14
14.5	189	126	247	227	473	383	609	540	799	1212	14.5
15	162	128	250	231	480	390	618	550	812	1230	15
15.5	164	130	254	234	488	396	627	559	825	1248	15.5
16	167	132	257	238	495	402	636	568	838	1266	16
16.5	170	134	261	241	503	408	645	577	851	1284	16.5
17	172	136	264	245	510	414	654	586	863	1302	17
17.5	175	138	260	249	517	420	663	595	875	1309	17.5
18	178	140	271	252	524	426	672	604	887	1336	18
18.5	180	142	275	256	530	432	682	612	899	1353	18.5
19	183	144	278	259	536	438	690	620	910	1370	19
19.5	185	146	282	263	542	444	699	628	922	1387	19.5
20	187	148	285	266	548	449	708	636	933	1404	20
20.5	190	150	289	270	594	455	717	643	945	1420	20.5
21	192	152	292	273	560	460	726	650	956	1438	21
21.5	195	154	295	275	566	465	735	657	968	1455	21.5
22	197	156	299	279	572	470	744	664	979	1471	22
22.5	199	158	302	282	578	475	752	671	990	1486	22.5
23	201	160	305	285	584	479	760	678	1001	1500	23
23.5	203	162	307	288	590	484	768	685	1012	1515	23.5

24	205	164	310	291	596	488	776	692	1022	1529	24
24.5	207	165	314	294	602	492	784	699	1033	1543	24.5
25	210	167	317	297	608	496	791	706	1043	1557	25
25.5	212	169	320	300	614	500	798	713	1059	1571	25.5
26	214	171	323	303	620	504	805	720	1064	1585	26
26.5	216	173	326	305	626	508	812	727	1074	1599	26.5
27	219	174	329	308	632	512	818	734	1084	1613	27
27.5	221	176	332	311	638	516	825	741	1094	1627	27.5
28	222	177	335	314	644	520	831	747	1104	1641	28
28.5	224	179	337	317	650	524	838	754	1114	1655	28.5
29	226	180	340	320	656	528	844	760	1124	1669	29
29.5	228	182	343	323	662	532	851	767	1134	1683	29.5
30	230	183	346	325	668	536	857	773	1143	1697	30
30.5	232	185	348	328	674	540	863	780	1153	1711	30.5
31	235	186	351	330	680	544	869	786	1162	1725	31
31.5	236	188	354	333	686	548	876	793	1172	1739	31.5
32	239	189	357	335	692	552	882	799	1181	1753	32
32.5	240	191	360	338	697	556	889	806	1191	1767	32.5
33	242	192	363	340	703	560	895	812	1200	1791	33
33.5	244	194	366	342	709	564	901	818	1209	1795	33.5
34	246	195	369	345	715	568	907	824	1218	1809	34
34.5	248	196	372	347	720	572	913	830	1227	1823	34.5
35	250	197	375	349	726	576	919	836	1235	1837	35
35.5	252	198	377	351	732	580	925	842	1243	1851	35.5
36	254	200	380	354	737	584	931	847	1251	1865	36
36.5	256	201	383	356	743	588	937	852	1259	1879	36.5

Table 11.2 (Contd.)

1	2	3	4	5	6	7	8	9	10	11	12
37	257	203	385	358	748	592	943	857	1266	1893	37
37.5	259	204	388	360	754	596	949	862	1274		37.5
38	260	205	390	363	759	600	955	867	1281		38
38.5	262	206	393	365	765	604	961	872	1289		38.5
39	263	208	396	367	770	608	967	877	1295		39
39.5	265	209	398	369	776	612	974	882	1304		39.5
40	266	210	401	371	781	616	979	887	1311		40
40.5	267	211	403	373	786	620	985	891	1319		40.5
41	269	212	406	375	790	624	990	896	1326		41
41.5	271	213	408	378	795	628	996	901	1334		41.5
42	272	214	411	380	800	631	1001	906	1341		42
42.5	274	216	413	382	805	635	1007	910	1349		42.5
43	275	217	415	384	810	638	1012	915	1356		43
43.5	277	218	418	386	815	642	1018	920	1364		43.5
44	278	219	420	388	820	645	1023	925	1371		44
44.5	280	220	422	390	824	649	1029	929	1379		44.5
45	281	222	425	392	828	652	1034	934	1387		45
45.5	283	223	427	394	832	656	1040	939	1394		45.5
46	284	224	429	396	837	659	1045	944	1401		46
46.5	285	225	432	399	842	663	1051	948	1409		46.5
47	287	227	434	401	847	666	1056	953	1416		47
47.5	289	228	437	403	851	669	1062	958	1424		47.5
48	290	229	440	405	855	672	1067	963	1431		48
48.5	292	230	442	407	859	676	1073	967	1439		48.5

49	293	231	444	409	863	679	1078	972	1446	49
49.5	294	232	446	411	868	683	1084	977	1454	49.5
50	296	234	448	413	872	686	1089	982	1461	50
50.5	298	235	450	415	876	690	1095	986	1469	50.5
51	300	236	453	417	880	693	1100	991	1476	51
51.5	301	237	455	419	884	697	1105	996	1484	51.5
52	302	238	457	421	888	700	1110	1000	1491	52
52.5	303	239	459	423	892	704	1115	1005	1499	52.5
53	304	240	461	425	896	707	1120	1009	1506	53
53.5	305	241	463	427	900	711	1125	1014	1513	53.5
54	307	243	465	429	904	714	1130	1018	1520	54
54.5	309	244	467	431	908	718	1135	1023	1527	54.5
55	310	246	469	433	912	721	1140	1027	1534	55
55.5	311	247	471	435	915	725	1145	1032	1541	55.5
56	313	248	472	437	919	727	1150	1036	1548	56
56.5	314	249	474	439	923	730	1155	1040	1554	56.5
57	315	250	476	441	927	733	1160	1044	1560	57
57.5	316	251	478	443	930	736	1165	1046	1567	57.5
58	317	252	480	445	934	739	1170	1052	1574	58
58.5	319	253	482	447	938	742	1175	1056	1580	58.5
59	320	254	485	449	942	745	1180	1060	1586	59
59.5	321	256	487	451	945	748	1185	1064	1592	59.5
60	323	257	489	453	948	751	1190	1068	1598	60
60.5	324	258	491	455	951	754	1195	1072		60.5
61	325	259	492	457	955	757	1200	1076		61
61.5	326	261	494	459	958	760	1205	1080		61.5

Table 11.2 (Contd.)

1	2	3	4	5	6	7	8	9	10	11	12
62	328	262	496	461	961	763	1209	1084			62
62.5	329	263	498	463	964	766	1214	1088			62.5
63	330	264	500	465	968	769	1218	1092			63
63.5	331	265	502	467	971	772	1223	1096			63.5
64	333	266	504	469	974	775	1227	1099			64
64.5	334	267	507	471	977	778	1232	1103			64.5
65	335	268	509	472	981	781	1236	1106			65
65.5	336	269	511	474	984	784	1241	1110			65.5
66	338	271	513	475	988	787	1245	1113			66
66.5	339	272	515	477	991	790	1250	1117			66.5
67	340	273	517	479	995	793	1254	1120			67
67.5	341	274	518	481	998	796	1259	1124			67.5
68	343	275	520	483	1002	799	1263	1127			68
68.5	344	276	521	485	1005	802	1268	1131			68.5
69	346	277	523	487	1009	805	1272	1134			69
69.5	347	278	524	489	1012	808	1276	1137			69.5
70	349	280	525	491	1016	811	1280	1140			70

Table 11.3. Drinking Water Quality Standard Adopted from WHO and Government of India, Dissolved Chemicals in ppm

Parameters	Permissible	Excessive
pH	7.0 to 8.5	Less than 6.5 or more than 9.2
TDS	500	1500
Total Hardness (CaCO ₃)	300	600
Ca	75	200
Mg	25	150
Fe	0.3	1.0
Cl	250	1000
SO ₄	250	400

Table 11.4. Suitability of Ground Water for Irrigation Purpose Adopted from U.S. Salinity Laboratory Criteria1) *Salinity hazard:*

Low	: TDS = 75 to 150 mg/l
Medium	: TDS = 150 to 500 mg/l
High	: TDS = 500 to 1500 mg/l
Very high	: TDS = 1500 to 3000 mg/l

2) *Alkali hazard:*

	At TDS = 75 mg/l
Low	: SAR = 0 to 10
Medium	: SAR = 10 to 18
High	: SAR = 18 to 26
Very high	: SAR = 26 to 32
	At TDS = 3000 mg/l
Low	: SAR = 0 to 10
Medium	: SAR = 2 to 7
High	: SAR = 7 to 11
Very high	: SAR = 11 to 32

Note: TDS = Total dissolved solids in mg/l
= 2/3 (specific conductivity approximately)

SAR = Sodium absorption ratio

$$= \text{Na} / \left(\frac{\text{Ca} + \text{Mg}}{2} \right)^{1/2} \text{ in epm.}$$

Case Study for Silewara Colliery, Maharashtra (Fig. 11.3)

The exploratory boreholes were drilled using a rock roller bit of size 7-7/8 in. (800 mm) up to 300 m and the boreholes electrically logged and parameters viz., spontaneous potential and point resistance measured. Subsequent to the careful study

of the log and its comparison with the lithology of the hole, the granular zones were demarcated for aquifer zone tests. The strata usually met with comprised of alluvium, sandstone, shale and coal. The top aquifer zone in respect of first bore-hole (BHE-1) extended from 68 to 90 m. The packer was set from 64 to 66 m with 100 mm blank 66 to 70 m, slotted 70 to 74, blank 74 to 80 and the last slotted from 80 to 85 m. Once the test assembly was lowered and the hole was reamed to a depth of 64 m and for the packer 13 $\frac{3}{4}$ in., i.e., (345 mm)

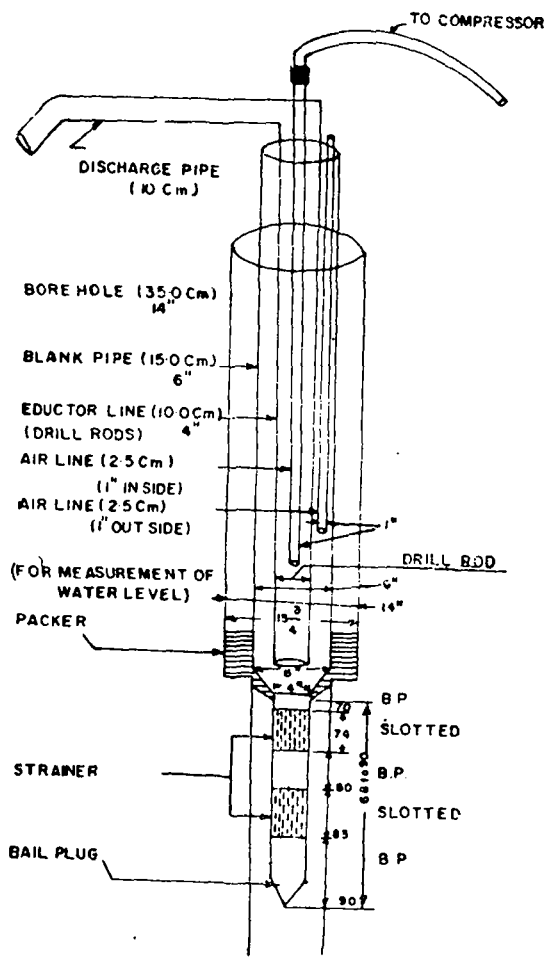

Fig. 11.3. Drill Stem Test Conducted at Sitewara Colliery

or up to 64 m. The packer was generally set in impervious strata to avoid leakage and hydraulic connection of two granular zones.

After reaming, the drill pipes were pulled out and 7½ in. bit was lowered. The hole was then washed up to 90 m. The drill rods and bits were pulled out; 6 in. pipe was placed above the packer and 4 in. fabricated assembly, i.e., blank pipe, slotted and bail plug were lowered and the packer set. Mud balls were put above and around the packer for about 20 ft (6 m) and some drill cutting were also added to add extra weight and then the borehole filled up with thick bentonite mud up to ground level. The drill pipes were lowered into the 6 inch (150 mm) pipe with the air line of 1 in. (25 mm) and after the first compressor started running, mud was discharged out of the drill pipe; and then zone-water gradually started coming after the mud was washed off.

The discharge was measured with a barrel (220 litres) and tape was lowered inside 6 in. (150 mm) pipe to know the level of water for computing drawdown. The water level was measured up to 20 m bgl after compressor was stopped while water level was 30 m when running and hence drawdown was 10 m. The compressor was run from 1½ to 2 hours till the water was cleared. The water level was allowed to recoup to know as to how much water would be recharged to the strata. This took two-three hours. This is done in shortest possible time. The entire operations were done with competence, swiftness and technical know-how, failing which the very method of testing would make the test assembly to be jammed and lost. Later the same procedure was adopted for testing the rest of the five individual aquifer zones up to 300. The procedure which was applicable to the first well was repeated in the other wells. The result of the tests carried zonewise in BHE-I are tabulated in Table 11.3-11.5.

From this, it could be seen that aquifer zone tests were very helpful in arriving at the figure of yield available from the individual strata and the drawdown that one would get. It ultimately helps us to fix the location of the pumping well 12/8 in. (300/200 mm) in the well field as well as the observation well locations around the well field. This procedure was adopted in the Silewara Colliery. Three exploratory wells of 300 m, followed by one pumping well and six observation wells were made in

Table 11.5. Results of Drill Stem Tests

<i>S. No.</i>	<i>Zones (m)</i>	<i>Yield (lpm)</i>	<i>Water level (m.bgl)</i>	<i>Drawdown</i>
1)	20—50	192	15.88	10.00
2)	68—90	135	17.30	11.28
3)	98—158	150	17.52	10.59
4)	170—200	35	25.30	22.00
5)	210—248	28	47.46	37.00
6)	288—305	Negligible	—	—

Silewara Colliery. The testing by Turbine pump was done to calculate storage coefficient transmissivity, etc. This helped to plan out their depillering operations in Silewara Mines.

Selection of Pumps

Pumping is done to draw water. The use of pumping equipment is dependent on water level conditions of tubewells and its capacity.

However, generally the following types of pumps are commonly used.

- 1) Deep Well Turbine Pump.
- 2) Submersible Pump.
- 3) Centrifugal Pump.
- 4) Air Lift Pump.

In tubewell drilling, force pumps, deploying deep well multi-stage turbine pumps, multistage submersible pumps, centrifugal pumps are invariably used for well development and for final installation.

1. DEEP WELL TURBINE PUMPS

These are modified form of centrifugal pumps. Centrifugal force is used to move the water through the pump but the design and construction is so, that higher pressures for suction heads could be obtained than with the straight centrifugal pumps. The length of impeller and its housing make up for one stage and next stage is added in sequence one above the other, with drive shaft extending to the surface. The discharge of the one impeller becomes the suction of the next impeller and so on, till the higher pressures so built up are obtainable. These are known as multistage pumps. Usually one stage can give a lift head of 20 to 25 ft (6-7.5 m) or so depending upon the design. Such type of pumps are subjected to wear due to sand

content found in water which shortens its life. The discharge pressure depends on the diameter of impeller and increases with the number of stages in pump. The deep well turbine pump is used primarily for pumping large quantities of water for irrigation, industrial and drinking purposes.

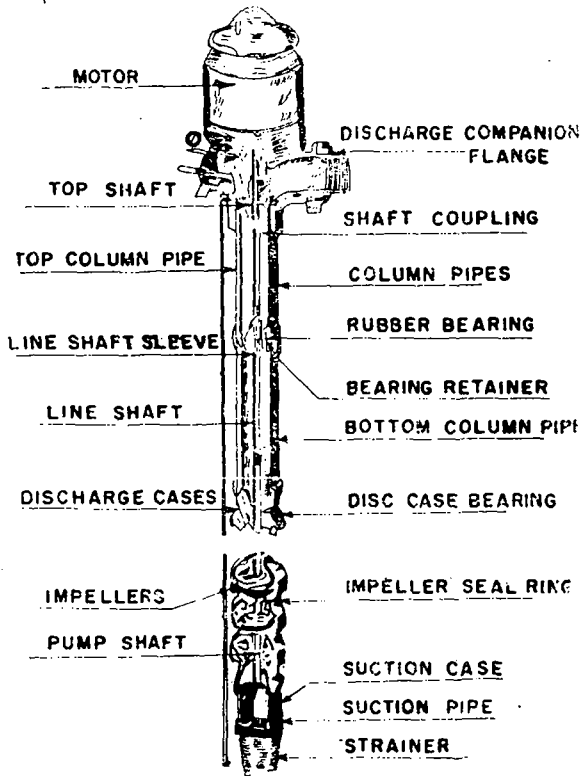

Fig. 12.1. Deep Well/Turbine Pumps Water Lubricated

These could be oil-lubricated and water-lubricated. These days the water lubricated pumps are being used more. Both are practically the same. The oil-lubricated pump has outer oil pipes tubing but at the top of the bowl, the oil is dispersed away. As some oil gets mixed with water, this is not preferred. The oil-lubricated pump is used when pump is operated on frequent stop and start basis (Fig. 12.1, Table 12.1).

The Salient Features of Turbine Pump

- 1) Positive displacement pump.
- 2) Size range 4 to 10 inch (100 mm to 250 mm), 2 to 150 hp for lifting water capacity 15 to 2800 gpm (67.5-12600 litres/min).
- 3) It has stainless steel shaft.
- 4) Dynamically balanced impellers, semi-closed and open.
- 5) Simplicity with less flow area for proper selection of pump.
- 6) Well should be vertical in which pump is to be lowered.
- 7) Well should be fully developed with compressor. It should be sand-free.

Main Components

- a) Suction Strainer.
- b) Pump Bowl Assembly (127 mm, 177 mm, 215 mm)
- c) Column Assembly of size (100 mm, 152 mm, 203 mm)
- d) Stainless Steel shaft (25 mm, 30 mm and of 3 metres length).
- e) Discharge head (100 mm, 150 mm, 203 mm) (which could be fitted with three types of drive heads:
 - i) Vertical electric motor, (ii) V-belt drive, and (iii) Right angled drive, head with diesel prime mover.

COLUMN ASSEMBLY (WATER-LUBRICATED)

Lubrication of the line shaft is being done by the same water which is being pumped through column pipes. The assembly consists of steel column pipes, high tensile steel shaft with stainless steel couplings and the required number of cast iron spiders fitted with synthetic rubber bearings. Stainless steel couplings are positioned at bearing points which revolve inside the rubber bearing and serve the purpose of shaft sleeves. Special care is taken in threading the pipes and line shaft ends to secure accurate alignment.

COLUMN ASSEMBLY (OIL-LUBRICATED)

In the oil-lubricated column, the line shaft is enclosed in steel tubing extending the full length of the column. Tubes are connected by closely spaced line shaft bronze bearings threaded to serve also as tube couplings. The shaft enclosing

tube is threaded and machined to very close limits, to ensure perfect alignment, and water tight joints. It keeps water away from shaft and ensures positive oil lubrication to the shaft bearings. A shaft tube tensioning device and a spider fitted in the column at interval, keeps the shaft assembly straight within the column pipe, thus preventing the deflection and misalignment.

PUMP BOWL

This comprises cast iron suction case, pump bowl, top bowl and stainless steel pump shaft. All parts are precision machined and water passages are hand-finished to obtain hydraulic efficiency. Impellers are dynamically balanced to ensure smooth running. Impellers are closed or of semi-open type with smooth vanes giving maximum efficiency.

DISCHARGE HEAD

It is located above the foundation level which supports the driver and provides the base for column and bowl assembly to be suspended. It is of cast iron, robust construction provided with smooth discharge elbow which minimises losses. The discharge head could be fitted with any type of drive, electric motor, flat/V-belt or gear head.

Table 12.1. Technical Details of Turbine Pump

<i>Minimum diameter of tubewell required (mm)</i>	<i>Recommended diameter of tubewell (mm)</i>	<i>Range of discharge capacity (lpm)</i>	<i>Bowl assembly head per stage (mtrs)</i>	<i>Speed (rpm)</i>
50-500	200-600	300-26000	22.9-30	1440

Maintenance

It should be checked and cleaned when giving sand. Impellers need replacement when less discharge is given.

Advantages

- 1) Access to repair to the primemovers is easier as installed on the surface.
- 2) They are cheaper on long run due to better efficiency and consequent smaller power consumption.

- 3) Suitable for high yield and high head.

Disadvantages

- 1) It is costly as pump house has to be made which increases the cost.
- 2) Lubrication and alignment of shaft critical.
- 3) Subject to sand abrasion.

Metric horse power in kg-m/sec of Turbine pump is calculated by the formula:

$$\text{Metric h.p.} = \frac{Qwh}{75 \times \text{efficiency}}$$

where Q = Discharge in cubic metres/hour; h = Head in metres;
 w = Weight of water in kg.

Example: $Q = 150 \text{ m}^3/\text{hrs}$; $h = 30 \text{ m}$; Efficiency = 0.76

$$\text{Metric h.p.} = \frac{150 \times 1000 \times 30}{60 \times 60 \times 75 \times 0.76} = 21.93 \text{ kg-m/sec}$$

$$\text{Wattage} = 21.93 \times 0.73 = 16.0 \text{ KW}$$

2. SUBMERSIBLE PUMP

They are of recent development and have considerable promise for future application. It is multistage centrifugal pump which forms a compact unit in conjunction with submersible motor at lower end. It has dynamically balanced impellers of mixed/radial flow design. The complete unit consisting of submersible pump and submersible motor fitted below is suspended from discharge rising pipe, which is firmly screwed to the servicing edge of the well by means of supporting clamp, with only the rising pipe and cables coming out of the well. All bearings are water-lubricated and protected from ingress of sand and other particles (Fig. 12.2, Table 12.2).

Pumps with radial flow are used for low capacity and high total head. Pumps with mixed flow are used for medium capacities and medium heads. The non-return valve located at the top of the pump in discharge outlet connection is streamlined for smooth flow. It normally has screwed or flanged connections.

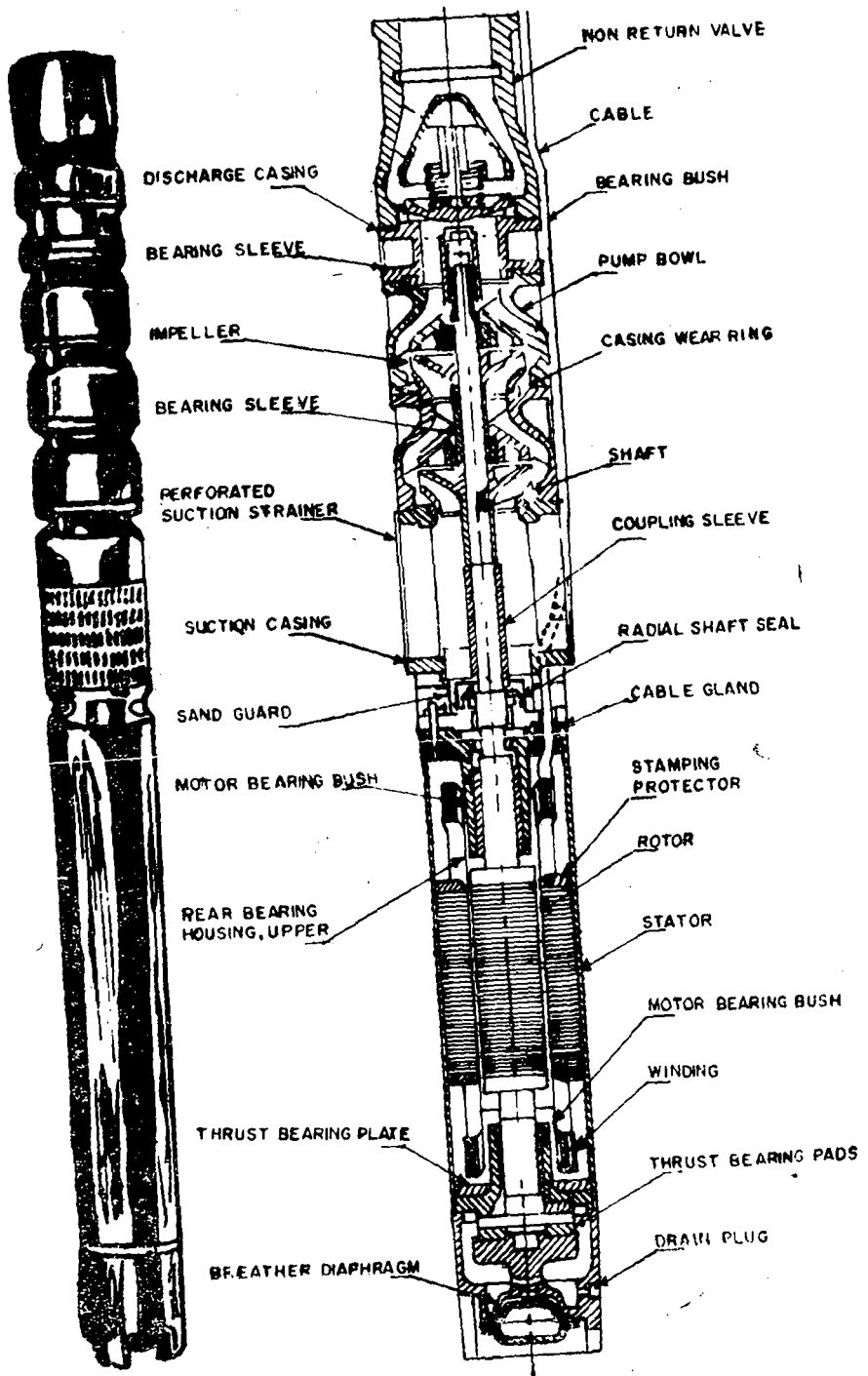

Fig. 12.2. Submersible Pumps and Motors

Submersible motors are wet squirrel cage induction motors filled with clean water. The water filling serves to lubricate the bearings and cool the waterproof insulated windings. Motor is sealed effectively from top to bottom against contamination. The axial thrust generated by the pump is absorbed by thrust bearings arranged at the bottom of the motor. Motors are normally wound for 400/440 volts 3 phase AC supply or through generating set. These motors can be supplied for direct on-line starting or start delta starter.

Motor could be wet or dry, but wet one is preferred. Wet stator are designed either for water-filled operation or oil filled operation. In case of wet stator pump filled with water, no attempt is made to prevent the water to contact the motor winding. The motor parts are made of non-corrosive material. The lamination is made of silicon steel, since they must have magnetic properties and are coated with corrosion resistance material.

In dry motors the stator windings are hermetically sealed against pump liquid by means of stainless steel tube along with stator bore sealed at each end. These are called semi-wet motors as only stator is dry and the rest of the motor is filled with water.

In American design, the submersible motors exclude the water from motor housing by filling it with non-hygroscopic water repellent and high dielectric strength mineral oil which prevents insulation against breakdown. Both type of wet motors are provided with mechanical shaft shield. In case of water-filled motor, this seal prevents the tubewell water coming in contact with clear water filled in the motor. Similarly in case of oil-filled motors the seals prevent the oil from leaking out into the tubewell and prevents water entering into motor windings.

Table 12.2. Technical details of Submersible Pumps

<i>Max. OD of pump (mm)</i>	<i>pump bore size (mm)</i>	<i>Discharge range (lpm)</i>	<i>Total head rating (mtrs)</i>	<i>Speed (rpm)</i>
142-187	142-187	100-2400	16-93	2900

Advantages/Disadvantages

- i) Easy to instal.
- ii) Requires small space.
- iii) No need for elaborate foundation.
- iv) Economy and quickness of operation.
- v) Cost of superstructure is eliminated.
- vi) No suction problem as all the water is forced up the pipe.
- vii) Low maintenance cost.
- viii) Noise free.
- ix) Cannot be installed when there is sand problem.
- x) Can be lowered in crooked holes.
- xi) Wide application for irrigation, industrial and drinking supplies.

Metric horse power in kg-m/sec of submersible pump is calculated by the formula:

$$\text{Metric h.p. (kg-m/sec)} = \frac{QW \times h}{75 \times \text{Efficiency}}$$

Example:

$$\begin{aligned} Q &= 150\text{m}^3/\text{sec} \\ h &= 30\text{m} \\ \text{Eff.} &= 0.58 \end{aligned}$$

$$\text{Metric h.p.} = \frac{150 \times 1000 \times 30}{60 \times 60 \times 75 \times .58} = 28.75$$

$$\text{Wattage } 28.75 \times 0.73 = 21\text{KW}$$

Factors Governing Selection of Pump

The following factors need to be considered in selection of pump.

- 1) Yield of well. Maximum yield is to be decided by test pumping.
- 2) The specific capacity of the well may be determined.
- 3) The pumping rate of well should be so selected that lower pumping could be done for extended hours of pumping for ensuring longer life of pump.

4) The expected drawdown for pumping rate

$$= \frac{\text{pumping rate}}{\text{specific capacity of well}}$$

Suppose pumping rate is 100 gls/mt (454 liter/mt)

Specific capacity is 5 gpm/ft (22.7 liter/mt)

$$\text{Expected drawdown} = \frac{100}{5} = 20 \text{ ft (6m)}$$

5) Sum of depth of static water level plus drawdown plus other factors would decide as to which type of pump is to be installed—turbine pump or submersible pump.

6) Allowance of seasonal fluctuation drawdown and other unforeseen circumstances may be totalled to decide the pump setting.

7) Use of the turbine pump may be indicated if the water level depth is more than 25 feet and the top housing is large enough to accommodate the pump bowl.

8) The total pumping head with pumping rate decides the capacity of the pump to be installed.

9) Purchase price of the pump is to be considered.

10) Cost of operating pump and maintenance are to be studied.

11) Availability of spare parts is also to be kept in view.

12) Selection of prime-movers is to be decided depending upon availability and condition of site for installation.

13) If all these factors are properly looked into, it would enable the best selection of the pump.

3. CENTRIFUGAL PUMP

In its action, it is reversed water turbine. It is capable of delivering large volume of water against low head, and suction is within 6 metres. It is fitted at the surface, if the water table is near the surface or fitted on scaffolding, after sinking well curbs. Practical suction lift is 6 metres. Its applicability is limited. It is cheap but efficient in working. The well has to be shallow and suction within workable limits. It is light. Since it runs at high speed, it is damaged by grit; it becomes inefficient when worn out or operating under unstable condition (Fig. 12.3).

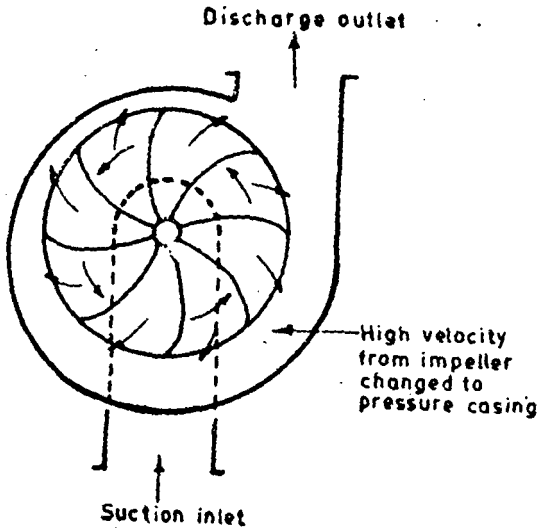

Fig. 12.3. Section of Centrifugal Pump

4. AIR LIFT PUMP

Compressed air is used to raise from the drilled well. The air lift pump consists of two pipes, large delivery pipe (eduction pipe) and small air pipe connected to the compressor receiver. The delivery pipe open at both ends is submerged into water, proportionate to the depth and greater than the height to which the water is to be lifted. The air pipe can be either inside type or outside type in the eduction pipe. Outside type is for permanent installations while inside pipe is used during general development sequences with the aid of compressor.

A perforated tool piece for injecting air blast is attached to the lower-most end of pipe. Air lift is effected by aeration or buoyancy of air and consequently making it lighter in the confined space to come up on the surface. The mixture of air and liquid formed inside the drop pipe, being lighter than outside the pipe makes the mixture to rise. The energy operating the air lift is the amount of the compressed air fed into the well and the driving force causing the pump to operate is unbalanced difference of the head column outside/inside the drop pipe (Fig. 12.4).

The starting percentage submergence and working submergence are of importance and are calculated as below:

$$\text{Starting submergence \%} = \frac{h_1}{H} \times 100$$

$$\text{Working submergence \%} = \frac{h_2}{H} \times 100$$

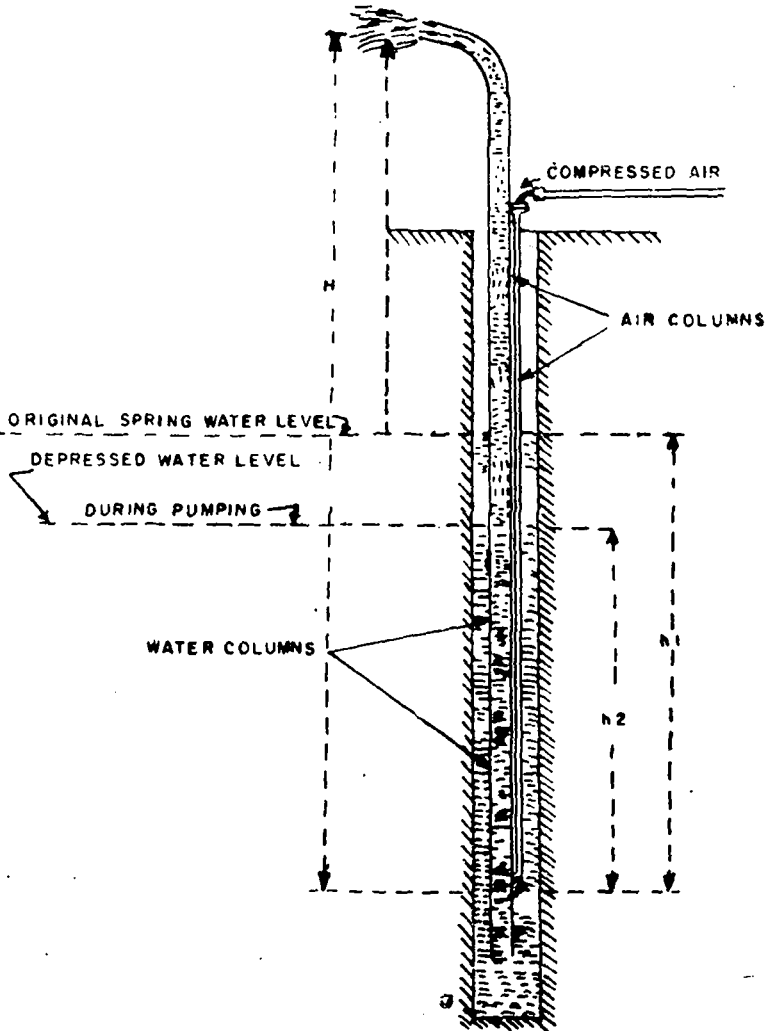

Fig. 12.4. Air Lift Pump

Where H = the total lift; h_1 = the distance where air enters the eduction pipe when there is no pumping, i.e., from

the static water level; $h_2 =$ is the distance where air enters when there is pumping;

$$L = \text{Net lift} = H - h_2.$$

In practice, it is found that the submergence varies with the lift; smaller lift requiring greater submergence percentage.

Messrs Ingersoll Rand Ltd., an American air compressor manufacturing concern recommends the following submergence percentage against lifts (Table 12.3):

Table 12.3 Recommended Submergence Percentage Against Given Lifts

<i>Lift</i>	<i>Percentage submergence</i>
50	70 to 66
50 to 100	65 to 55
100 to 200	55 to 50
200 to 300	50 to 43
300 to 400	43 to 40
400 to 500	40 to 33

Where drop pipe and air line are used, Table 12.4 shows the sizes which may be used to best advantage.

Air development produces best results if submergence percentage ratio is 60 per cent. This is the proportion of air length below water when pumping is in progress. It is important that the optimum quantity of air is used. If too much air is supplied it would result in excessive receiver pressure friction in pipe and waste of air. If scanty air is used it will give less water discharge of pulsating type. The compressor should be capable of developing maximum pressure not less than 100 psi and preferably 150 to 200 psi. The air pressure is equivalent to frictional loss in air pipe and water pressure caused by submergence.

A thumb rule is to provide $3/4$ cubic foot of free air for each gallon of water at the anticipated rate. The following empirical formula for determining the correct quantity of air to be required is

$$\text{ed is } V = \frac{h}{c \log \frac{H + 34}{34}}$$

where $V =$ cubic ft of free air required per gallon of water lifted; $h =$ total lift in ft; and $c =$ constant depending upon working percentage submergence H .

Working percentage (%)

H	75	70	65	60	55	50	45	40	30
'c'	366	358	348	335	318	296	272	246	216

Total lift $h=60$, Submergence 65%

$$V = \frac{60}{348 \log \frac{65 + 34}{34}} \text{ cubic feet per gallon of water pumped.}$$

$$= \frac{60}{348 \times .441} \quad \text{---do---}$$

$$= .39$$

Discharge 500 gl/minute

$$\text{Hence quantity of air required} = 500 \times .39$$

$$= 195 \text{ cubic feet of air/mt}$$

As the size of compressor is indicated in cubic feet of air, this would give us the size of compressor.

Regarding relative size of air pipe to the delivery pipe it is in the ratio 1 : 3

If the eduction pipe is 4"

$$\text{then inlet pipe} = 1/3 \times 4 = 1\frac{1}{3} \text{ say } 1\frac{1}{2}''.$$

Table 12.4. Sizes of Well Casing, Drop Pipes and Air Lines for Various Discharge Capacities

<i>Pumping rate</i> <i>L/mt</i>	<i>Diameter of</i> <i>well casing</i> <i>(m)</i>	<i>Diameter of</i> <i>drop pipe</i> <i>(mm)</i>	<i>Diameter of</i> <i>air-line</i> <i>(mm)</i>
136—272	87 larger	62	19
272—340	112 "	75	25.40
340—454	125 "	87	31.75
454—681	150 "	100	37
681—1435	200 "	125	37
1435—1816	200 "	150	50.80

Column of 0.7 metres of water would require pressure of 0.07 kg per sq cm for lifting.

After ascertaining the size of air pipe, eduction pipe/starting and working submergence the air lift is put into operation. The air pipe should be 1.5 metres within drop pipe. This will prevent wastage of air which then could be effectively used. A portable compressor is best suited. It has been seen that inside air-line

Table 12.5. Pump Selection Chart

<i>Type of pump</i>	<i>Practical suction lift</i>	<i>Usual pumping depth</i>	<i>Advantages</i>	<i>Disadvantages</i>	<i>Remarks</i>
1) Volute centrifugal pump	3 metres	1.5-3 mts	<ol style="list-style-type: none"> 1. Smooth even flow. 2. Pumps water containing sand and silt. 3. Low initial torque. 4. Reliable and assured service. 5. Shock-free service. 6. Used for medium heads 	<ol style="list-style-type: none"> 1. Looses prime easily. 2. In spite of good efficiency requires operation under designed head and speed. 3. Suction limitation maximum 7.5 metres. 	Efficient up to 250 lmp discharge and head up to 50 metres. Suitable for revitalising dug-cum-bore well.
2) Centrifugal pump-turbine single stage-multi-stage	3.5 metres	3.5 mts	<ol style="list-style-type: none"> 1. Self priming. 2. Suitable for high heads. 3. It maintains prime. 	<ol style="list-style-type: none"> 1. Same as above. 2. Not suitable for sandy water. 	—

3) Deep well turbine pump	Impellers submerged	3.4 mts	<ol style="list-style-type: none"> 1. Same as volute type centrifugal pump. 2. Suitable for high yield and high heads. 3. Suitable for vertical wells. 4. Repairing can be done with ease. 	<ol style="list-style-type: none"> 1. It needs straight well for installation and operation. 2. Lubrication and alignment of shaft critical. 3. Subject to sandy abrasion. 4. Good efficiency but requires operation under design head and speed. 	<p>Only when there is trouble in column pipe or bowl assembly the pump has to be removed.</p> <p>Except for initial cost its performance is dependable.</p>
4) Submersible pump	Pump and motor submerged	7.15 mts	<ol style="list-style-type: none"> 1. Alignment of shaft is less critical than Turbine Pump. 2. Less maintenance problem. 3. Economic in installation. 4. Noise-free operation. 5. Short pump shaft 6. More efficient 	<ol style="list-style-type: none"> 1. Repairs to motor and pump requires removal from well and sending to workshop. 2. Subject to abrasion from sand. 3. Only suitable for silt free water 4. Only operated with electricity. 	<p>Sealing of electrical equipment ensures long and trouble free service. Protection of motor against power failure to be done.</p>

Table 12.5 (Contd.)

<i>Type of pump</i>	<i>Practical suction lift</i>	<i>Usual pumping depth</i>	<i>Advantages</i>	<i>Disadvantages</i>	<i>Remarks</i>
5) Airlift pump	Eduction pipe should be submerged deep enough so that pressure at the bottom is greater than the weight of mixture of air and water.	—	<ol style="list-style-type: none"> 1. Very simple. 2. No moving parts. 3. Easy to operate and maintain. 4. Efficiency 40 to 70 per cent. 5. Suitable for handling certain amount of silty water. 6. Fool proof. 	<ol style="list-style-type: none"> 1. Not suitable for permanent installation. 2. Discharge pulsating. 3. Efficiency low. 4. Not suitable for yield which are either too small or too large and overheads involved are high. 5. Operational cost very high. 	

is more convenient to use. Both drop pipe and air line could be used simultaneously.

The testing with air lift could be conducted till the conditions have stabilised with the discharge becoming sand free. The air line may be used at different depths. Starting from bottom to top at various levels and for number of times, the air lift is operated to ensure complete development of the well.

Air lift is simple and easily maintained. It will produce a small volume of water from small well. It offers least trouble as there are no moving parts. It can be used in all the wells and even installed in crooked wells, where water is muddy and overhead installation is difficult to put. The principle disadvantage is that the wells are to be made deeper than to be used with any other type of pumps, to secure adequate submergence of air outlet. The efficiency is low between 45 to 20 per cent for depth of 15 to 180 metres.

A submergence of 2.25 times the lift, gives the maximum efficiency of the system.

Role of PVC in Well Construction

Introduction

Tubewell failure is a major problem in all parts of the country. Most of the tubewells fail due to corrosion of mild steel screens and it is estimated that the life of a tubewell ranges from two years in highly corrosive areas to 15 years in areas with good quality water. The use of PVC casings and ribbed screens can successfully prevent such failures.

Advantages of PVC Screens

The PVC screens offer the following advantages:

- i) *Resistant to corrosion:* PVC ribbed screens and casings are of superior materials as compared to steel, since they do not corrode.
- ii) *PVC pipes have less weight:* Being lighter than steel, they can be shifted to even distant places with great ease.
- iii) *Easy to install:* Installation is extremely easy. Casing pipes can be lowered in a well in the shortest time.
- iv) *Better flow characteristics:* PVC ribbed screens have superior flow characteristics and the horizontal slotting thereon maintains the strength of the pipe.
- v) *Cost:* The total installation with PVC casings and screens will be less costlier as compared to that of mild steel; and depending upon the depth, there can be substantial savings.

Characteristics of Ribbed Screens

PVC screens have ribbed sections on the outside surface. The zones with ribs keep granular material away from the slots and increase the permeability to more than double in compari-

son with screens with smooth surfaces. The high rounded ribs on screens prevent direct contact of gravel with the screens in the area of slots and it is this which provides particularly good hydraulic properties to these screens.

The slotted design is shown in (Fig. 13.1; 13.2).

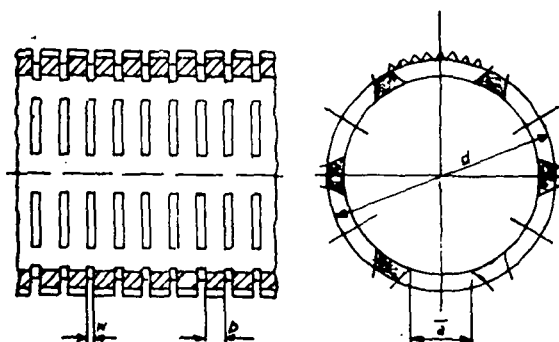

Fig. 13.1. Slotting in the Circumference of a PVC Pipe

Table 13.1. Ribbed Screen Pipes

Dia	Outer dia of pipe <i>D</i>		Max. dia over joints <i>D</i>	Wall thickness <i>S</i>	
	Min.	Max.		Min.	Max.
mm	mm	mm	mm	mm	mm
40	48	48.2	56	3.5	4.0
50	60	60.2	68	4.0	4.6
100	113	113.3	125	5.0	5.7
150	165	165.4	183	7.5	8.5
200	225	225.5	247	10.0	11.0

Table 13.2. Plain Casing Pipe

Size	OD in mm		Wall thickness			
			Shallow wells (Depths up to 80 m)		Medium wells (Depths > 80 m but < 250 m)	
mm	Min.	Max.	Min.	Max.	Min.	Max.
40	48.1	48.4	3.1	3.7	3.1	3.7
50	60.2	60.5	3.9	4.5	3.9	4.5
100	114.1	114.5	4.5	5.2	6.0	6.9
150	165.0	165.5	6.6	7.6	8.8	10.2
200	225.0	225.7	7.6	8.8	11.0	12.7
250	250.0	250.8	8.5	9.8	13.8	15.9
300	315.0	316.0	10.7	12.4	17.3	19.9

Table 13.1; 13.2 give the specifications of ribbed screen pipes and casing pipes.

Method of Jointing

They have threaded joints. These joints have good strength and can take up the suspended weight of the assembly for great depths. Table 13.3 gives tensile strength of the joints (in kg).

Table 13.3. Strength of Joints for Screen Pipes

Diameter (mm)	Permissible tensile strength of joints (in kg)	
	Shallow wells	Medium wells
40	1,400	1,400
50	1,800	1,800
100	4,000	4,000
150	2,300	6,600
200	2,300	8,000

Characteristics Collapse Resistance

Collapse resistance is important to avoid failure of casings and screens. Collapse resistance is calculated as below:

$$P_c = \frac{2E}{(1-u)^2} \times \frac{(S)^3}{(D)^3}$$

Where P_c = Collapse pressure; E = Modulus of elasticity; S = Thickness of wall; D = Diameter; and u = Poisson's ratio.

By selecting the right ratio of Diameter to Wall Thickness, it is possible to obtain the suitable casing for the required condition. The Standard Dimension Ratio varies between 16 to 28 for PVC casings and screens. For example, the collapse resistance for different Standard Dimension Ratio for casings and screens is given below:

SDR	P_c (bar)
16	15
20	8 to 9
28	3 to 5

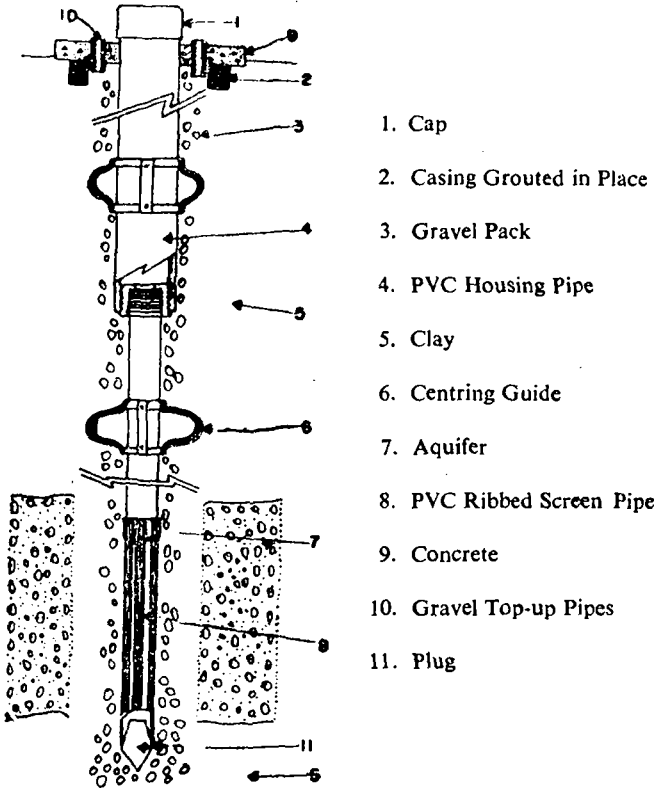

1. Cap
2. Casing Grouted in Place
3. Gravel Pack
4. PVC Housing Pipe
5. Clay
6. Centring Guide
7. Aquifer
8. PVC Ribbed Screen Pipe
9. Concrete
10. Gravel Top-up Pipes
11. Plug

Fig. 13.2. Cross-section of Tubewell with PVC Casing and Ribbed Screen

Fishing Tools and Practices

Whenever the tools are lowered in a hole, they are subjected to larger stresses resulting in mechanical failure. Sooner or later, another common source of trouble encountered in drilling operations is the sticking of equipment inside the hole, due to caving formations, excessive mud filter cake, accumulation of drill cuttings or wedging, prevent easy withdrawal of tools and create excessive stresses on the drill rig. The technique of removal of equipment, which is caught/stuck up or fallen in a hole accidentally, is called fishing. The development of fishing industry has paralleled the growth of drilling industry, as both have close basic relationship between them.

Fishing

Fishing for equipment in hole is an art as each fishing operation needs different treatment, depending on the type of fish, the way it is lying and other features connected with it. It may be suited to a particular job and different jobs need different tools/techniques. However on account of similarity of equipment used, in most drilling operations, some more or less standard fishing tools have been manufactured.

When the equipment is lost in the hole, it must be removed as early as possible to resume drilling. The longer it stays, more are the chances of its recovery to recede and recovery becomes difficult. The actual cost of fishing tool is smaller in comparison to rig time lost and idling charges of the rig. If the equipment cannot be recovered this could be side-tracked so that drilling can be resumed. If it is small, we may drill over it or drill another hole if fishing is uneconomical and time consuming.

A broad classification of fishing technique is done under two heads.

- A. Those used to recover the tubular products.
- B. Those used to recover the miscellaneous equipment.

There are three types of fishing tools.

- I. Inside fishing tool and outside fishing tool.
- II. a) Tools which position the fish for engagement by other tools.
- b) Miscellaneous equipments.
- III. Hydraulic impact tool.

The Causes of Trouble for Fishing Jobs

1) Fatigue failures caused by excessive stresses. When the rotary tables continue to turn, with the lower portion of the pipe stuck up.

2) Failure of down-the-hole equipment, due to corrosion/erosion by drilling fluids.

3) The drill line parting by applying excessive pulling weights.

4) Mechanical failures of the parts of the drilling bit or thread failure.

5) Accidental dropping of pipe wrench, plate, bolt or giving away of welding in the hole.

If a fishing job is present, the entire position is to be carefully analysed in respect of the following.

- Depth of hole.
- Depth of fish.
- Position of the top of fish, its size and shape.
- Angle at which it is lying, the length of fish whether threaded/unthreaded.
- The formations in which it is held up.
- Condition of drill and equipment.
- Strength of derrick and drill line.

So as not to complicate the fishing operation, with the failure of the surface equipment, sound condition of drill and equipment is very important. After proper consideration, the suitable fishing tool should be run inside the hole. It would be ideal, if the fish is recovered in the first attempt. With the elapse of time, drill cutting are like to settle, thus lessening the chances of recovery. No amount of measurement at the surface

can determine the position of fish in the hole whether the fish is free or otherwise. Impression block is lowered to take the impression of the fish. A short block of wood having a diameter slightly less than the hole is fitted with the soap, wax or nails and is lowered from the surface. The impression thus obtained would enable us to find out its position and tools which would be needed to release the fish (Fig. 14.1).

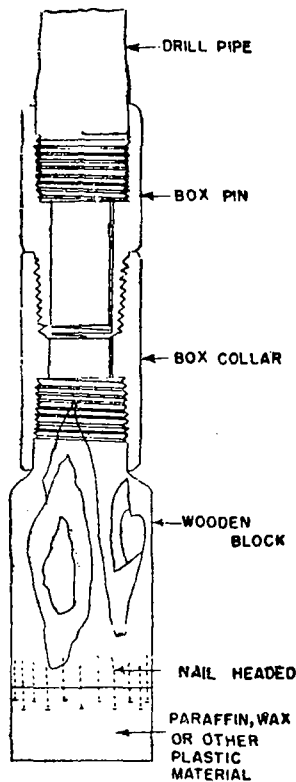

Fig. 14.1. Impression Block

There are releasing and non-releasing fishing taps (Fig. 14.2 a, b). The disadvantage of non-reversible fishing taps is that if once the fish is caught but in case it cannot be retrieved due to excessive loads, there is danger of damage to the rig and derrick. In that case, reversible fishing tools are more helpful. Non-reversible type has limited use. Its principal advantage is

low cost. It is of not much advantage with rotary drilled wells where quick and efficient method is required.

Non-reversible type of fishing tool can be improved with reversible releasing mechanism.

If the top of fish is unobstructive, tapered fishing tap or die overshoot can be effective for fishing.

The circulating slip overshoot permits the circulation of drilling fluid and is used while rotating with circulating mud to catch the fish and pull it out.

Inside and Outside Fishing Tools

Brief description of fishing tools used in rotary drilling is as follows.

a) TAPERED TAP

It is tapered about 2.54 cm per 30.4 cm length from a diameter somewhat smaller than the inside of the fish and ranging to the diameter equal to the outside diameter of the coupling to be recovered. It is made of heat treated steel. The tapered portion of which is threaded and fluted so that the steel material which is cut by the threads can escape through these flutes. The upper end of the tool has box connection to allow it to be lowered with drill pipes. Its action is that of machine tap as it cuts its own threads when rotated and grips the fish for pulling it out.

b) DIE OVERSHOT

The die overshoot is long tapered heat treated steel having taper of 2.54 cm in 30.4 cm length. It has box connection at the top. The taper thread is fluted to permit escape of metal cut out by the threads. The tool is hollow but circulation cannot be completed to the bottom of the hole because the flutes allow the fluid to escape.

c) CIRCULATING SLIP OVERSHOT

It is a tubular tool about 91.44 cm long with inside diameter

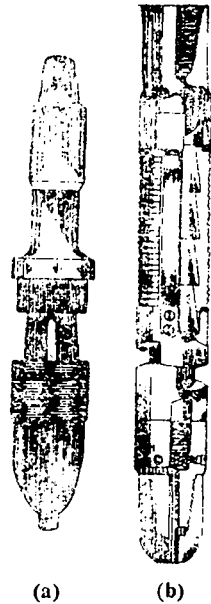

(a) (b)
 Fig. 14.2 a, b. Spear Releasing and Non-releasing Type

slightly bigger than outside diameter of the fish. The bottom is belled out and a notch is cut so that the tool can enter and encircle the fish, i.e., last drill pipe. The outside body of the circulating slip overshot is made of two pieces screwed together. The top of lower section of the body is recessed to receive the rubber packing ring and a sleeve. The sleeve bore is tapered. On the inside of the sleeve is a ring type slip, which has left hand threaded bore. This slip has a slot cut on one of its side to help it to expand as the rod passes through it and tightens against them as it is pulled down into the tapered sleeve (Fig. 14.3).

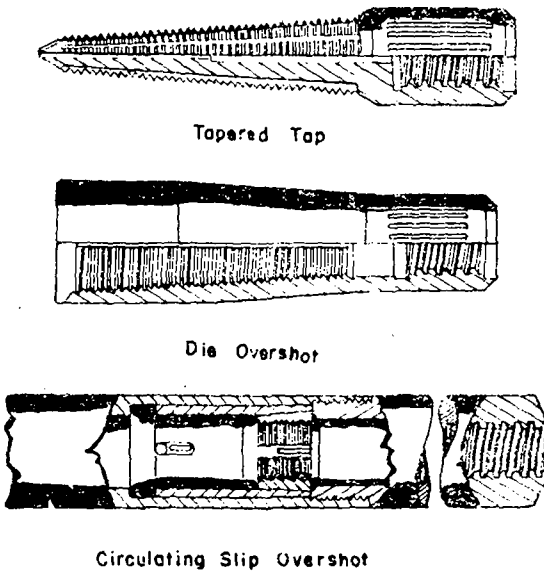

Fig. 14.3. Fishing Tools for Rotary Drill

The body, sleeve and slips are fastened together with lugs so that they operate as one unit, yet having a small vertical movement also.

As the circulating slip overshot goes over the stuck rods the slip grips the pipe and sleeve is pulled down against the rubber packing which makes a seal between the fishing tool and drill rod. This ensures that if the circulation is made, it is through lost drill pipe.

The fishing tools for percussion drill are listed below (Fig. 14.4).

- 1) Babcock socket.
- 2) Fishing jars.
- 3) Casing spear.
- 4) Friction socket.

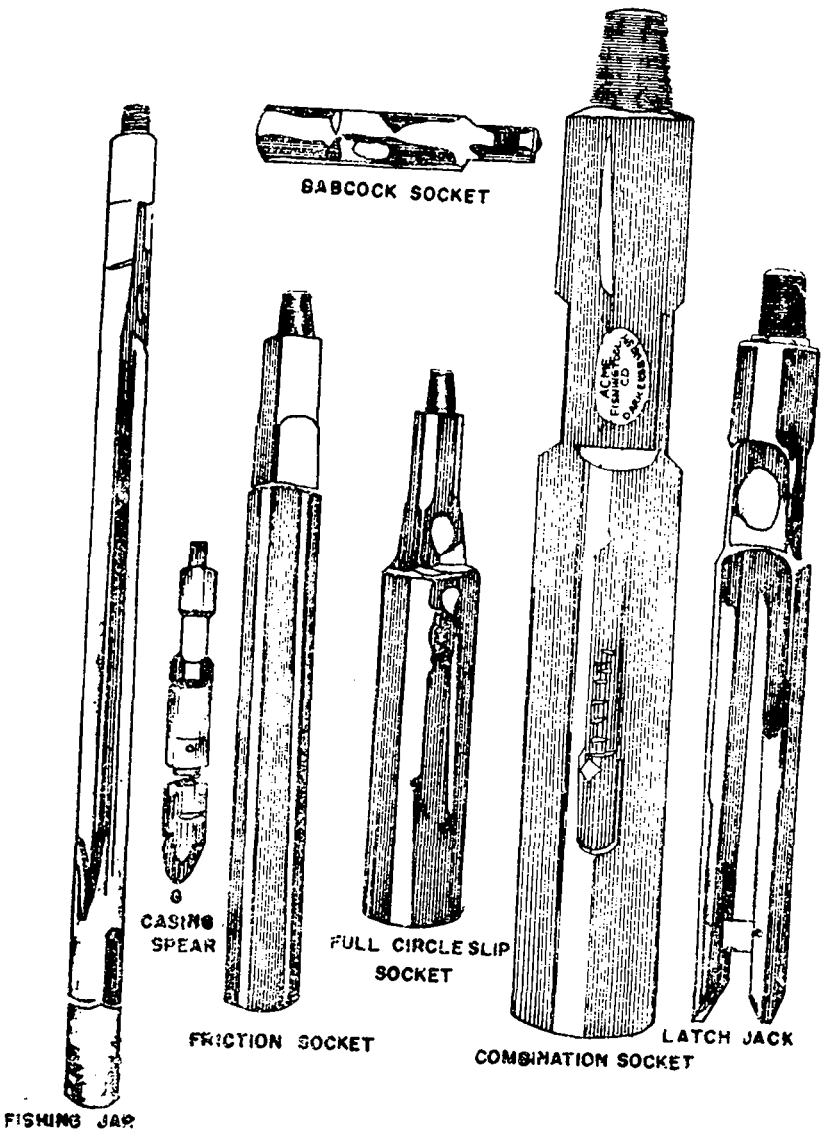

Fig. 14.4. Fishing Tools for Percussion

- 5) Full circle slip socket.
- 6) Combination socket.
- 7) Latch jack.

1) BABCOCK SOCKET

It is used against regular swivel socket in fishing operations. It can be attached to the drilling line. It is to restrict the rotation of the fish to the minimum.

2) FISHING JAR

Fishing jar is same as regular jar but its strokes are much longer. It is attached above the fishing tool and below the fishing stem. Without this, upward jarring is not possible. It is not wise to do fishing without fishing jars. The fishing stem has maximum length of 3 metres. It is shorter than drilling stem.

3) CASING SPEAR

The loss of casing is complicated fishing job. It results from caving, freezing, parting and splitting of casing. This can be fished out by casing spear.

4) FRICTION SOCKET

When a bit is unscrewed or broken off a friction socket is used. It is to be examined properly whether socket has actually positioned on to the top of bit and it has taken a strong grip enough to pull up the tool.

5) FULL CIRCLE SLIP SOCKET

It has hardened steel slips on the inside which will take firm grip on the tool than the friction socket. The slips are in various sizes for catching a broken drill stem box collar, pin or other round material. It is best suited when the tool is frozen in the hole due to cave-in or drill cuttings. Avoid jarring up and down unless the lost tools cannot be loosened otherwise.

6) COMBINATION SOCKET

Combination socket is to catch the neck of rope socket or pin of bit or tool which becomes unscrewed in the hole. It can be used to catch any cylindrical tubing provided the bore is (32 cm) longer than the diameter of the piece to be caught.

7) LATCH JACK

It is to fish out bailer/sand pump. A latch consists of two heavy prongs with a latch at the bottom which works inside the prong body. It is a pin connection at the top for lowering. The latch is lowered till the contact is made and the fish is caught. If the tool has been hooked additional power would be needed to pull it from the hole.

Other Fishing Tools

1) WASH OVER PIPE

The purpose of wash over pipe is to rotate over the fish, freeing it from the well of the hole and dislodging any solid material that may be sticking. Outside diameter of wash pipe must be small enough to run inside the drilled hole. Inside diameter must be larger enough to rotate over the fish. If the fish is short, it could be recovered in one piece otherwise it has to be washed in stages, divided into shorter pieces and recovered one piece at a time.

2) ROTARY SHOE

Lower end of wash over pipe carries a rotary shoe or tungsten carbide bit so that drilling can be done with the same, to cover the fish. Outside diameter of the rotary shoe should be larger than the diameter of the wash over pipe.

3) WASH OVER BACK OFF TOOL

By itself, the wash over pipe cannot catch the fish. Catch tools have been developed which can run at the top of the section of wash pipe. One such tool is the wash over back off tool which ordinarily engages the top of the fish by screwing into box connection on the top. With the fish thus engaged, the washed over section can be freed from the remainder of the fish by back off short pull.

4) LEFT HAND RODS AND LEFT HAND TAP

If all methods fail, and the rods are still stuck up the only alternative is to lower left hand tap and left hand rod and continue to unscrew the same in pieces before the hole is abandoned.

5) INSIDE CUTTERS

Sometimes inside cutters are worked by running cutting knives on the small diameter pipe inside the fish bore.

6) OUTSIDE CUTTER

There are jobs when no inside tool can be worked. For such fishing job the outside cutters are used.

Miscellaneous Equipment

1) THE MILLING TOOL

This is used to grind the fish into small pieces which can be brought to the surface with drilling fluid or junk basket. It can be ordinary drilling bit or a special type of bit or a solid head with a grinding surface. The use of carbide as a cutting surface is commonly used. This results in self-sharpening tool with long life.

2) JUNK BASKET

It is the tool run separately or in conjunction with milling tool. It is used to recover the broken pieces which may be too large to be removed with the circulating fluid.

3) MAGNETIC FISHING TOOL

Use of magnetic fishing tool has been successful for recovery of small objects. It may be either permanent type of electro-magnet type. In permanent type a powerful permanent magnet tool is located inside a non-magnetic material, the lower end is the engaging force and magnetic force is concentrated at lower surface. The tool is usually run on a drill pipe or tubing. A circulating hole is provided on most magnetic fishing tool to permit normal drilling operation. The electro-magnet type of fishing tool is run on electrical cable. Once the tool is in the hole over the fish, electric current is passed through the tool to energise the magnet.

4) SAFETY JOINT

Necessary item in safety joint is a device which permits release from the fish, in case it cannot be pulled out and the releasing mechanism becomes inoperative. This is located above

the fish and released through left hand torque. The upper part of the tool is released with tubing and the lower part remains in the hole with the tool.

Hydraulic Impact Tools

When the additional pull is desired which exceeds the capacity of derrick or drill line, hydraulic pulling can be used. The hydraulic pulling tool is essentially a hydraulic jack, with means of attaching to the fish and slips to engage the casing. The hydraulic pressure is generated in the tool by alternate raising and lowering of the fishing string. The pressure acts in several cylinders which are forced upward and tend to retain the fish which is engaged below by an overshot.

It places straight pulling force without placing corresponding strain on the fishing string because it is anchored by slips to the inside of casing and transfers much of pull to casing. Thus the pulling tool can release its upward force and gets disengaged.

But practically fishing operations cannot be avoided because they are part and parcel of the drilling operations. Mechanical failures are the cause of the frequent fishing which gives undue strains to the drill and equipment. If maintenance to the equipment is done, the number of fishing operations can be reduced.

Drilling Specifications

1. SPECIFICATION OF SLOTTED PIPE

200 mm and 150 mm size 3 mm

200 mm and 150 mm size 1.5 mm

For 200 mm \times 3 mm

- a) 14 rows with 3 slots in each row on the circumference, i.e., 42 slots with size of the slot 76.2 \times 3.16 mm distance between two slots being 4.7 mm. There will be four such sets, i.e., 168 slots in one Rft or .3 metre.

For 150 mm \times 3 mm

- b) 10 rows with 3 slots in each row on the circumference, i.e., 30 slots with slot size and distance between two slots being 4.7 mm. There will be four such sets, i.e., 120 slots in Rft (running feet on the pipe) or .3 metres.

For 200 mm \times 1.5 mm

- c) No. of slots = 240

20 rows with 3 slots in each row of the circumference, i.e., 60 slots with size of the slot 76.2 \times 3.16 mm. Distance between 2 slots being 3 mm. There will be four such sets, i.e., 240 slots/Rft or .3 metres.

For 150 mm \times 1.5 mm

- d) No. of slots = 192

16 rows with 3 slots in each row on the circumference, i.e., 48 slots with size of slot 76.2 \times 3.16 mm. Distance between 2 slots is 3 mm. There will be four such sets, i.e., 192 slots/Rft or .3 metres.

2. SPECIFICATIONS FOR A TRAILER MOUNTED HEAVY DUTY COMBINATION DIRECT ROTARY-CUM-PERCUSSION DRILLING RIG

The rig should generally conform to the following specifications.

Section I

CAPACITY

The rig should be capable of drilling

- 1) *By Percussion Method in Boulder and Hard Formations*
 - i) 50 to 60 cm diameter holes up to 305 metres using a tool weight 2000 kg (approx.)
 - ii) 40 to 50 cm diameter holes up to 457 metres using a tool weight of 1875 kg (approx.)
- 2) *By Direct Circulation Rotary Method*
 - i) 50 to 60 cm diameter holes up to 244 metres using 114.3 mm ($4\frac{1}{2}$ in.) drill rods.
 - ii) 30 to 40 cm diameter holes up to 457 metres using 114.3 mm ($4\frac{1}{2}$ in.) drill rods.
 - iii) 25 cm diameter holes up to 762 metres using 89 mm ($3\frac{1}{2}$ in.) drill rods.

MAIN FRAME AND TRAILER

Heavy structural steel frame, electric welded and fully twisted for maximum strength. The whole unit should be mounted on heavy duty trailer having tandem rear axles and detachable front dolly with single axle; all dual wheels of 9×20 size nylon tyres may be provided. The trailer should be complete with two bar, spare wheel, four levelling jacks, vacuum or air brakes for connection to truck, with indicator standard lights and other essential accessories. The trailer be so designed to withstand the load of various components fitted with the rig and should be so constructed as to have good mobility in negotiating hilly terrains and cross-country roads. The tenderers should stand guarantee for passing their trailer by Transport Authority.

MAST

Three legged telescopic type, heavy duty mast, 16 to 18 m high, capable of handling casing loads up to 45 tonnes on six lines using triple sheave block. The mast should be raised or lowered and telescoped by engine power through a separate worm gear driven mast raising drum having an independent clutch control. The capacity of the mast should be 46,000 kg and hook load should be 33,000 kg. Optional equipment of the third leg may be provided with the mast. Stand pipe mounting may be made on the mast. Arrangement for the drill pipe beam and trolley to lay drill pipes down may be provided.

The crown block should be of steel construction provided with minimum four casing line sheaves for triple sheave block operation and dead and anchor, drilling line sheave and sand line sheave. All the sheaves should be mounted on antifric-tion roller bearings. A cat-line sheave should also be provided.

The mast should be provided with telescoping ladder from ground to mast head and mounted with crow's mast at mast head.

DRUMS

The rig should be equipped with three drums, viz. Bull Reel, Sand Reel and Casing Reel. The drums should be of adequate size and capacity as under.

BULL REEL

The bull reel should be chain or gear driven and mounted on self-aligning spherical roller pillow block bearings. It should be provided with an adjustable divider and should have a spooling capacity of not less than 1000 m of 25 mm wire line, a single line pull of 12,000 to 15,000 kg on bare core. The Bull Reel should have double brakes of adequate size and should be driven through an independent clutch. Necessary drilling line should be included.

The wire rope having left hand regular lay construction group 6 × 19 non-spinning not less than 1000 m should be provided with the Bull Reel.

SAND REEL

It should be chain or gear driven and mounted on antifric-

tion roller bearings. It should be equipped with an adjustable divider, should have spooling capacity of about 1000m of 14.3 mm (9/16 in) wire rope and a single line pull of approximately 4,500 kg on bare drum. The Sand Reel should be provided with double brakes and should be driven through independent clutch. Necessary sand line should be provided.

The wire line not less than 1000m having right hand regular lay non-spinning construction group 6 × 37 should be provided with sand reel.

CASING REEL

It should be chain or gear driven and mounted on self-aligning spherical antifriction roller pillow block bearings. It should be equipped with an adjustable divider and double brakes of adequate size and have a single line pull of not less than 5000 kg on bare drum. The Casing Reel should be controlled by an independent clutch and be provided with necessary casing line.

Wire rope 170m of right hand regular lay construction group 6/37 of adequate diameter should be provided with casing line.

CAT-HEADS

The conveniently located cat-heads should be provided. One of the cat-heads should be suitable for making and breaking out joints of drill pipes. Necessary catline roller should be provided. The cat-heads should preferably be independently controlled.

SPUDDING BEAM

The double arm spudding beam should be of all steel electric welded construction driven by double pitmans and cranks. The pitmans should be provided with adjustable bushings and cranks should have three or four positions for pitmans connection to provide spudding strokes from 50 to 110 cm; suitable heel and spudding sheaves mounted on antifriction roller bearing should be provided. Line brake and spooling device should be furnished on drill line heel sheave. The spudding drive should be by V-belts through an independent clutch. The spudding beam should be provided with friction brakes to hold the spudding beam in an up and down position when not in use.

SHOCK ABSORBERS

The rig should be provided with suitable shock absorbers either in the mast head or in spudding beam to cushion the shocks during percussion drilling.

CLUTCH SHAFT, COUNTER SHAFT AND CLUTCHES

The shafts should be of heat treated alloy steel and should be mounted on self-aligning spherical roller pillow block bearings.

The Bull Reel, Sand Reel, Casing Reel and spudding beam should have independent clutches. The clutches should be of adequate size and preferably be air actuated. A suitable air compressor for actuating the air clutches should be provided with necessary auxiliaries such as air storage tank, air line filter and lubricator, control valves, pressure gauge etc.

BRAKES

All the three drums should have double brakes of adequate size. The brakes should be self-equalising type capable of easy adjustment.

POWER UNIT

The rig should be powered by 2 Nos. vertical high speed diesel engine four stroke, water cooled engine with radiator for tropical climate of 180 bhp at 2200 rpm with a continuous rating of 146 bhp at 1950 rpm for long duration operation. The engine should be complete with governor with positive locking control, automatic shut off, panel with control instruments, fuel tank, electric starter etc. (one engine for drilling line and another for mud pump). We shall, however, prefer the prime mover of Leyland make of indigenous origin.

DRIVE

Power from the engine to the clutch shaft should be transmitted through a multiple V-belt drive. All sprockets/gears should be machine cut, hardened and the chains should be precision high speed roller type.

TRANSMISSION

Heavy duty transmission giving at least four forward and one reverse speed should be provided,

SAFETY GUARDS

All moving parts, clutches, brakes, chains, V-Belts should be covered with cast-steel guards for safety and weather protection.

DRILL STEM GUIDE

Split type controller from ground level should be included!

ROTARY DRIVE

Complete rotary drive arrangement with independent air clutch should be provided.

ROTARY TABLE

Rotary table should be heavy duty having minimum 457.2 mm (18 inch) opening with master bushing and guides of strong and rugged construction.

Other attachments for direct rotary drilling such as stand pipe, rat holes digger etc. should be included.

WORKING PLATFORM

Suitable working platform with sufficient working space and steel steps etc. should be provided. Sub-structure for drilling rat-hole and rat-hole casing with proper drilling arrangements may be provided.

CONTROLS

All controls should be grouped at driller's position for easy operation.

MAINTENANCE EQUIPMENT

The rig should have at least one large tool box made of heavy gauge steel sheet, complete set of hand tools for the maintenance of the rig and engine, puller sets, special tools, general purpose tools, for operation.

Spare parts book and maintenance manual etc. should be furnished.

Section II

MUD PUMP

It should be trailer mounted heavy duty duplex reciprocating mud pump of size 184 mm × 254 mm (7¼ in. × 10 in.) fully equipped for slush services with 165 mm (6½ in.) liners capable of delivering approximately 1200 lpm (316 USGPM) at about 31.5 kg/cm² (450 psi). The mud pump should be complete with air chamber, shear relief valve, pressure gauge, valve seat, puller, liner puller etc. It should be driven by a 4-stroke vertical high speed diesel engine of 180 bhp at 2200 rpm and a continuous rating of 146 bhp at 1950 rpm for long duration operation. The diesel engine should be water cooled with radiator, battery boxes, generator, governor with positive locking control, automatic shut-off, panel with control instruments, fuel tank etc. The whole unit should be utilised and mounted on a heavy duty full trailer, all wheels of proper size and rating. Suction and high pressure delivery hoses should be provided with necessary fittings.

LIGHTING PLANT

The rig should be provided with a generator having 3.5 KVA single phase AC supply 50 cycles per second having 230/250 volts at 1500 rpm for lighting purpose for operating the rig at nights. The prime mover of the generator should be an air cooled diesel engine of adequate bhp rating.

Section III

Percussion drilling equipment and tools, each set comprising of the following (all tool joints to API specifications and other authentic standards which ensure an equal or higher quality) should be provided.

<i>S.No.</i>	<i>Description</i>	<i>Qty.</i>
1.	139.7 mm (5½ in.) swivel socket	2 Nos.
2.	139.7 mm (5½ in.) Drilling Jar (Alloy Steel) Weldless type	2 Nos.
3.	127 mm (5 in.) drilling stem 7.31 metres (24 feet) long	2 Nos.
4.	Regular pattern drilling bits for 304.8 mm,	

<i>S.No.</i>	<i>Description</i>	<i>Qty.</i>
	381.00 mm, 457.2 mm and 533.4 mm (12 in., 15 in., 18 in., and 21 in.) holes.	2 Nos. each
5.	Star drilling bits (four wing pattern) for 304.8 mm, 381.00 mm, 457.2 mm and 533.4 mm (12 in., 15 in., 18 in., and 21 in.) holes	1 No. each
6.	Eccentric bits for 304.8 mm, 381.00 mm, 457.2 mm and 533.4 mm (12 in., 15 in., 18 in., and 21 in.) holes	1 No.
7.	Wire line saver	2 No.
8.	Swivel extra wireline socket	4 Nos.
9.	Bit gauge	1 No. (for each size bit)
10.	Tool wrenches	1 set
11.	Liners tool wrenches	1 set
12.	Circle and jack with handle and post	1 set
13.	Bar and chain tightener	1 set
14.	Flat valve bailers (273.0 mm × 4.267 m, 355.6 mm × 3.65 m, 406.4 mm × 3.65 m and 457.2 mm × 3.048 m (10 $\frac{3}{4}$ in. × 14 ft., 14 in. × 12 ft.), 16 in. × 12 ft., and 18 in. × 10 ft.)	1 No. each
15.	Sand pump rod type 273 mm × 4.267 m, 355.6 mm × 3.65 m, 406.4 mm × 3.65 m, 457.2 mm × 3.048 m (10 $\frac{3}{4}$ in. × 14 ft., 14 in. × 12 ft., 16 in. × 12 ft. and 18 in. × 10 ft)	2 Nos. each

FISHING TOOLS

16.	139.7 mm (5 $\frac{1}{2}$ in.) Babcock socket	1 No.
17.	Long stroke fishing jar 139.7 mm × 609.6 mm (5 $\frac{1}{2}$ in. × 24 in.) stroke	1 No.
18.	Fishing stem 127 mm × 3.048 m (5 in. × 10 ft.)	1 No.
19.	254 mm (10 in.) combination socket with neck slips and pin slips	1 No.
20.	Extension Bowl for combination socket	1 No.
21.	254 mm (10 in.) two-prong grab with latch jack bottom	1 No.

<i>S.No.</i>	<i>Description</i>	<i>Qty.</i>
22.	254 mm (10 in.) full circle slips socket with pin collar and box collar slips	1 No.
23.	Extension Bowl for full circle socket	1 No.
24.	Corrugated friction socket	1 No.
25.	Wire line knife cutting outfit	1 No.
26.	Solid jar Bumper 154.4 mm × 1.828 m (16¼ in. × 6 ft.)	1 No.
27.	Internal casing cutters for the above sizes of pipes	1 No. each
28.	Wire rope spear 2-prong	2 Nos.

PIPE DRIVING TOOLS

29.	Heavy duty p-type inside drop drive heads	1 No. (for each size of casing)
30.	Drive clamps, heavy pattern with wrenches	1 set
31.	Heavy duty drive shoes (4 sq threads per inch, parallel screwing to British standard 879, 1965) for 304.8 mm, 331 mm, 457.2 mm × 533.4 mm (12 in., 15 in., 18 in. and 21 in.) inside diameter casing, square threads flush butt joint)	6 Nos. (for each size)

PIPE HANDLING TOOLS, PIPE EXTRACTION EQUIPMENT AND TOOL

32.	Three sheave travelling block with swivel hook capacity 45 tonnes	1 No.
33.	Heavy duty chain tongs for pipe sizes of 50.8 mm to 304.8 mm (2 in. to 12 in.) with 8 spare sets of jaws and chains	8 Nos.
34.	Heavy duty chain tong for pipe size of 101.6 mm to 558.8 mm (4 in. to 22 in.) with 8 spare sets of jaws and chains	8 Nos.
35.	Heavy pattern casing elevators with links for 168.275 mm (6⅝ in.) O.D. casings	2 Nos.
36.	Heavy pattern casing elevator with links for 219 mm (8⅝ in.) O.D. casings	2 Nos.
37.	Heavy pattern casing elevator with links for 273 mm (10¾ in.) OD casing pipe	2 Nos.

<i>S.No.</i>	<i>Description</i>	<i>Qty.</i>
38.	Heavy pattern casing elevator with links for 323.85 mm (12 $\frac{3}{4}$ in.) O.D. casing pipes	2 Nos.
39.	Heavy patterns casing elevator with links for 355.6 mm (14 in.) O.D. pipe	2 Nos.
40.	Heavy pattern casing elevator with links for 406.4 mm (16 in.) O.D. pipes	2 Nos.
41.	—do— 482.6 mm(19 in.) O.D. pipes	2 Nos.
42.	—do— 558.8 mm(22 in.) O.D. pipes	2 Nos.
43.	Complete sets of heavy pattern casing rings, bushings and slips to handle 168.27 mm, 219 mm, 273 mm, 323.85 mm, 355.6 mm, 406.4 mm, 482.6 mm and 558.8 mm (6 $\frac{5}{8}$ in.), 8 $\frac{7}{8}$ in., 10 $\frac{3}{4}$ in., 12 $\frac{1}{4}$ in., 14 in., 16 in. and 22 in.) O.D. casing pipe for jacking of pipes	1 set
44.	Heavy duty hydraulic jacks assembly including another base, extension rods, jacks, pulldown head with adaptors for different sizes of casing and pump with diesel engine	1 set
45.	Maintenance tools in steel box (full set of tools proposed to be indicated)	

PIPE PERFORATION TOOLS

46.	Hydraulic pipe perforator for perforating 15 cm to 30 cm ID or larger sizes casing in the hole	1 set
-----	--	-------

Section IV

Direct Rotary Drilling equipment and tools, each set comprising the following (all tool joints to API specifications; other authentic standards which ensure an equal or higher quality

- 152.4 mm diameter (6 in.) \times 7.6 m (25 ft.) suction hose complete with fittings and strainer 2 Nos.
- 63.5 mm (2 $\frac{1}{2}$ in.) \times 12 m (40 ft.) High pressure wire braided swivel base suitable for a working pressure up to 1125 psi (78.37

<i>S.No.</i>	<i>Description</i>	<i>Qty.</i>
	kg/cm ²) testing pressure 2225 psi and (156.76 kg/cm ²) and bursting pressure 4500 psi (313.52 kg/cm ²) complete with fittings	6 Nos.
3.	Travelling block 381 mm (15 in.) triple sheave, double roller bearing, 40 tonnes safe working load with single latching hook for drilling line	1 No.
4.	Travelling block 381 mm (15 in. triple sheave, double roller bearing, 40 tonnes safe working load, with duplex hook for casing line.	1 No.
5.	Heavy duty stem type water swivel capacity about 40 tonnes 63.5 mm (2½ in.) diameter water course with heavy duty connections for swivel line	2 Nos.
6.	Sub-water swivel to kelly	2 Nos.
7.	117.5 mm (4½ in.) × 8.6 m (28 ft.) round three fluted kelly or 112.5 mm sq (4½ in. sq) × 8.6 m. (28 ft.) kelly	1 No.
8.	Sub-kelly to drill pipe	2 sets
9.	Kelly drive bushing with pins	2 sets
10.	88.9 mm (3¼ in.) external upset API grade 'D' range drill pipe manufactured from cold drawn seamless mechanical tubing complete with API internal flush screwed on type counter bore welded 120.6 mm (4¾ in.) tool joints complete with thread protractors. The drill pipe should weigh approximately 21.9 kg per metre and have well thickness of 9.55 mm	2 sets
11.	Drill pipe slips with lifting handles	2 sets
12.	Spare inserts for above (Item No. II)	2 sets
13.	Heavy duty central latch elevator for drill pipe, capacity approximately 40 tonnes complete with links	2 Nos.
14.	Rotary tongs complete with lug jaws, size range 73 mm (2¾ in.) to 324 mm (12¾ in.)	2 Nos.

<i>S.No.</i>	<i>Description</i>	<i>Qty.</i>
15.	Spare lug jaws for the above (Item No. 14)	4 sets
16.	203 mm × 3.05 m (8 in. × 10 ft.) drill collars with 168.2 mm (6.5/8 in.) API reg. box and pin connections	4 Nos.
17.	Slips for 203 mm drill collars with replaceable inserts complete with handle	1 set
18.	Spare inserts for the above item No. (17)	3 sets
19.	Safety clamp for 203 mm drill collar ("C" type)	2 Nos.
20.	Double tube core barrel size 155.57 mm to 190.5 mm, 6.096 m (6 $\frac{1}{8}$ in. × 7 $\frac{1}{2}$ in. × 20 ft.) log drop ball circulation type bottom discharge elevator type upper connection, box top connection including one sub to connect 88.9 mm (3 $\frac{1}{2}$ in.) internal flush drill pipe	6 Nos.
21.	171.45 mm (6 $\frac{3}{4}$ in.) hard formation core bit	24 Nos.
22.	Core catcher assembly	6 Nos.
23.	Taper fishing tap for 88.9 mm drill pipe	1 No.
24.	Rotary dia overshot for 88.9 mm drill pipe	1 No.
25.	Circulating and releasing slip type overshot to catch 88.9 mm drill pipe	1 No.

SUBSTITUTES FORGED HEAT TREATED ALLOY STEEL

26.	Complete set of substitutes to cover entire range of connections for Kelly, drill pipes, drill collars, stabiliser core barrel, different sizes bits, lifting and handling subs etc.	2 sets
27.	Suitable Hydraulic Rotary jar	1 No.
28.	200.025 (7 $\frac{7}{8}$ in.) tricone rock roller bits with 114.3 mm (4 $\frac{1}{2}$ in.) API reg. pin for medium hard formation (15 Nos.) and Hard formation (10 Nos.)	25 Nos.
29.	250.825 mm (9 $\frac{7}{8}$ in.) tricone rock roller bits with 168.275 mm (6 $\frac{5}{8}$ in.) API Reg. pin	
	<i>Med. Hard Hard</i>	
30.	311.18 mm (12 $\frac{1}{4}$ in.) " " 15 + 10	25 Nos.

<i>S.No.</i>	<i>Description</i>	<i>Qty.</i>
31.	381.00 mm (15 in) " " 15 + 10	25 Nos.
32.	444.5 mm (17½ in.) " " 15 + 10	25 Nos.

HOLE OPENERS

33.	508 mm (22 in.) three cutter hole opening bit with box end threaded to connect pilot bit, replaceable cutters type with 3 sets of spare cutters	2 Nos.
34.	609.6 mm (26 in.) three cutter hole opening bit with box end threaded to connect pilot bit replaceable cutters type with 3 sets of spare cutters	2 Nos.

WRENCHES

35.	Heavy duty pipe wrenches 90 cm (36 in.) (Rigid type)	20 Nos.
36.	Heavy duty pipe wrenches 120 cm (48 in.) (Rigid type)	20 Nos.

Section V

List of spare parts for rig engine and Mud Pump indicating their cost for three years operation should be submitted.

3. SPECIFICATIONS OF DIRECT CIRCULATION ROTARY DRILLING RIG CAPACITY 500 METRES

Direct Circulation Rotary Drilling Rig suitable for drill in all parts of hard abressive alluvium soils, thick layers of hard clays mixed with *kankar*, sand stone and small size of gravel etc. The rig should broadly conform to the following specifications.

CAPACITY

The rig should be capable of drilling the following size holes with drill rods size 88.9 mm (3½ in.).

<i>Holes size</i>	<i>Depth</i>
a) 470 mm to 510 mm	100 m
b) 310 mm to 400 mm	400 m
c) 170 mm to 200 mm	500 m

MOUNTING

The rig should be mounted on a heavy duty trailer, all steel welded sturdy frame, so as to withstand the load of various components of the drilling rig, such as mast, draw works, mud pump, etc. The trailer should be fitted with tyre size 900×20 of adequate numbers.

MAST

The mast of the rig should be heavy duty strong and sturdy structural steel construction, electric welded with sufficient number of cross members for maximum strength, so as to withstand a safe working load of not less than 40 tonnes. The height of the mast should be about 15 metres. It should be provided with swivel guide track, crown block having suitable number of sheaves to carry out hoisting and lowering operations when drilling and casing the wells and for other operations. The crown block sheaves should be mounted on roller bearings. The mast should be provided with 90° tilt arrangements, operated by two hydraulic jacks (cylinder). The mast should be horizontal when the rig is in transit and vertical when drilling.

DRAW WORKS

The draw works of the rig should be enclosed type and built in strong steel frame having two separate hoisting drums, for drilling line, and other for casing line of adequate spooling capacity and single line pull. The draw works should have independent clutches driven through double/triple link chains and should be provided with heavy duty type double hand brakes to handle the design load. Both the drums should be provided with suitable length and diameter of wire ropes. Two cat-heads on ends of drums shaft. One clutch operated should be provided with draw works. Sand line reel with 500 m of wire rope size 12 mm diameter with friction clutches and brakes should also be provided.

ROTARY TABLE

The rotary table of the rig should be completed enclosed oil bath type with an opening not less than 18 in. (457 mm), with master bushing in two pieces.

TRANSMISSION

The rig should be provided with heavy duty transmission oil bath type, having four forward and on reverse speeds with master, clutch to draw works and rotary table.

POWER UNIT

The rig should be powered by two number diesel engine four stroke water cooled of adequate BHP rating, for powering, the mud pump, rotary table, draw works and hydraulic pump etc. The engine should be complete with fuel tank, radiator, batteries, self starter, dynamo, etc.

COMPOUND DRIVE CASE

The rig should be equipped with compounding arrangements for permitting one engine to power the mud pump and the other to power the draw works, rotary table or both engine, be compounded to power the mud pump, draw works and rotary table or either or both engine may be used on draw works.

MUD PUMP

The rig should be provided with a reciprocating type pump having discharge capacity of about 1000 lpm at 300 psi (20 kg/cm²).

CONTROL

All the control buttons/switches should be located at one place, at the driller's position for easy operation.

LIGHTING PLANT

Size numbers heavy duty mechanical levelling jacks should be provided with the rig.

OPERATING EQUIPMENT

1. Kelly's 4½ in. (114 mm) square × 28 ft. (8.5 metres) long with API box connection on

- the top water level swivel and API pin connection at the bottom. 1 No.
2. Drive bushing for $4\frac{1}{2}$ in. (114 mm) square kelly and rotary table 1 No.
 3. Suitable substitute for connecting water swivel to kelly 2 Nos.
 4. Suitable substitute for connecting kelly to drill pipe 2 Nos.
 5. Tong hanger and counter balance weight assembly 2 per set 1 set
 6. Travelling block with hook suitable for safe working load of 30 tonnes for drilling line 1 No.
 7. -do- for casing line 1 No.
 8. Heavy duty water swivel capacity about 40 tonnes oil bath type, $2\frac{1}{2}$ in (63 mm) diameter course with $2\frac{1}{2}$ in. (63 mm) heavy duty connections for swivel hose, bail with kelly guide and standard accessories. 1 No.
 9. Drill rods $3\frac{1}{2}$ in. (88.9 mm) O.D. external upset API guide-D manufactured from cold drawn seamless steel tubing with $3\frac{1}{2}$ in. (88.9 mm) API internal flush two joints fitted with drill rods, in about 6 metres length 100 Nos.
 10. Slips (2 pieces) with handles and jaws for drill rods size $3\frac{1}{2}$ in. O.D. 2 sets
 11. Heavy duty centre latch elevator with links for (114 mm) $3\frac{1}{2}$ in. drill rods. 2 Nos.
 12. Casing elevators with links for 14 in. (354 mm) O.D. casing, (310 mm) $12\frac{1}{4}$ in. O.D. casing, $10\frac{1}{4}$ in. (260 mm) O.D. casing, $8\frac{5}{8}$ in. (219 mm) O.D. casing, and $6\frac{5}{8}$ in. (168 mm) O.D. casing. 1 No.
 13. Slips with bushing complete for 14 in. (354 mm) O.D. casing, $12\frac{1}{4}$ in. (310 mm) O. D. casing $10\frac{3}{4}$ in. O. D. casing, $8\frac{5}{8}$ in. (244 mm) O.D. casing, and $6\frac{5}{8}$ in. (168 mm) O.D. casing. 1 No.
 14. Subs for connection of bits sizes $6\frac{3}{4}$ in (171 mm), $7\frac{5}{8}$ in. (219 mm), $8\frac{1}{2}$ in. (215 mm),

- | | | |
|-----|--|--------|
| 46. | Box end wrenches | 1 set |
| 47. | 100 ton mechanical jacks | 2 Nos. |
| 48. | 20 ton hydraulic jacks | 2 Nos. |
| 49. | 50 ton mechanical jacks | 2 Nos. |
| 50. | Recommended spares for five years for smooth operation and maintenance of drilling rig and its various components. | |

Note: The above specifications are for general guidance. The rig should be complete with all accessories and components so as to function to its rated capacity.

4. SPECIFICATION FOR SLOT PERFORATOR MACHINE

<i>Specifications</i>	<i>Standard accessories</i>
1. No. of spindles (Horizontal) 12	1. Heavy duty steel structure base and extended columns
2. Distance of slots centre to centre: 6 in. (152 mm)	2. Heavy gear transmission
3. Mesh Range (Slot width) 0.062 to 0.250: in. (1.58 mm to 6.35 mm)	3. 'V' Block with two sets of hardened wear plates
4. Slot length: 3 in. (76 mm)	4. Outboard spindle supports with leave centres
5. Maximum Saw diameter: 4½ in. (114 mm)	5. Pipe roller lifts built on to base
6. i) Casing size: 4 to 14 in. (102 mm to 356 mm) ii) Thickness of pipe 4.5 mm to 7 mm	6. Indexing device for equal spacing of slots
7. Pipe length: (4 to 8 metres)	7. Coolant Tank (integral with base)
8. Maximum length per cycle: 6 ft. (1.80 metres)	8. Automatic feed mechanism
9. i) Spindle rpm 150 to 190 ii) Number of speeds 4	9. Pneumatic system for roller uplifts and pipe gripping.
10. Vertical feed (infeed): 1 min. 30 sec. for full traverse	10. Unified remote control panel

<i>Specifications</i>	<i>Standard accessories</i>
11. -do- (return): 45 second for full traverse	11. One set of saw collar bushings for three saws per spindle.
12. Average cycle time: less than 3 minutes	12. Air compressor 10 cfm of 150 psi.
13. Line power: 220/440 V	
14. Spindle drive motor: 15 H.P.	
15. Feed drive motor (in-feed): 3 H.P.	
16. Feed drive motor (return): 3 H.P.	
17. Coolant pump motor: 1 H.P.	
18. Electric control system: 220 V.	

5. SPECIFICATIONS FOR TURBINE PUMP

1. Normal size:	4 in. × 3 in. (101.6 mm × 76 mm)
2. Capacity:	5000 G.P.H.
3. Total head:	150 ft (45 metres)
4. Bowl/Assy/Max. O.D.	5 $\frac{5}{8}$ in. (142 mm)
5. Impeller:	Bronze
6. No. of stages:	18 (Eighteen)
7. Type of lubrication:	Water lubricated
8. Column assy. Size:	4 in. × $\frac{7}{8}$ in. (100 mm × 22 mm)
9. Length of column pipes 10 ft. long	15 numbers
10. Discharge head:	Surface discharge
11. Input duty point:	5.26 h.p.
12. Max. input	5.87 h.p.
13. Bowl efficiency:	72%
14. Recommended h.p. of engine:	7/10
15. Type of drive:	Right angled gear head drive
16. R.P.M.:	1440
17. Suitability:	Suitable for min. 6 in. (150 mm) tubewell (perfectly in plumb)

- 18) The complete unit: Bowl assy. prime mover, gear head, universal joint shaft, line, shaft etc.

6. SPECIFICATION FOR SUBMERSIBLE PUMP

<i>Sl. No.</i>	<i>Description</i>	<i>Quantity required</i>
1.	Submersible pump having the following size and specifications.	1 set
i)	Outside diameter of pump:	90 mm/92 mm.
ii)	Tubewell bore size:	150 mm (naked bore in hard rock areas).
iii)	Discharge outlet:	50 mm
iv)	Total water head:	60 metres.
v)	Discharge:	1/2 cu. sec. (approx.)
	Pump should be supplied with 3 phase generator coupled with suitable prime mover and all other switch gear etc.	

7. SPECIFICATIONS AND REQUIREMENT OF STEEL WIRE ROPE

- 3/4 in. diameter ungalvanised round steel wire rope; basic grade confirming to I.S. 2266/77 for lifts and hoists purposes.

Diameter	:	3/4 in. (19 mm)
Construction	:	6×19 filler with wires laid (12/6 to 6F/1 with IWRC).
Lay	:	Right regular lay
Core	:	Fibre main core
Fabrication	:	Non-preformed
Strength	:	110/120 tons per sq inch
Length	:	786 metre in (131 metres) length in wooden reel
- 5/8 in. (16 mm) diameter ungalvanised round steel wire rope; basic grade confirming IS 2365/1963 for lifts and hoists purposes.

Diameter	:	3/8 in. (9.5 mm)
----------	---	------------------

- | | | |
|--------------|---|--|
| Construction | : | 6×19 filler with wires laid [12/6 to 6 F/1]. |
| Lay | : | Right regular lay |
| Fabrication | : | Non-preformed |
| Strength | : | 110/120 tons per sq inch. |
| Length | : | 244 metre in 122 metre piece length in wooden reel |
- 3) 7/16 in. (11 mm) diameter round steel wire rope; basic grade conforming to IS No. 1856/1961 for haulage purpose.
- | | | |
|--------------|---|--|
| Diameter | : | 7/16 in. (11 mm) |
| Construction | : | 6×7 filler with wire laid 6 × 6. |
| Core | : | Fibre core |
| Fabrication | : | Preformed |
| Strength | : | 110/120 tons per sq inch |
| Length | : | 1218 metre in (761 and 457 metre) piece length on wooden reel. |

8. SPECIFICATIONS OF DRILLING MUD

Drilling mud consisting of finely powered bentonite/gel forming clay suitable for water well drilling and should conform to the following specifications:

1) DENSITY

Density of the liquid mixing 30 grams of dry drilling mud in 500 cc of water should be 1030 kg to 1080 kg per cubic metre.

2) SETTING PROPERTY

30 grams of the drilling mud will be thoroughly mixed with 500 cc of water and will be allowed to settle. After 24 hours, the suspended solids shall occupy not less than 90 per cent of the total liquid volume.

3) SAND CONTENTS

Zero to five per cent.

4) GEL STRENGTH

After mixing at 14,000 rpm, difference in time taken for the

fluid through a marsh funnel before and after resting 10 minutes should not less than 0.25 sec.

5) COLLOIDAL PROPERTIES

Thickness of the mud cake formed with fluid or concentration @ 30 grams of drilling mud in 500 cc, of water is 5 to 8 mm.

9. SPECIFICATIONS OF BARYTES POWDER

- 1) Barytes powder conforming to API specifications should have the following physical and chemical properties.
 - i) Specific gravity: 4.20 minimum
 - ii) Soluble alkaline earth metals as calcium: 200 ppm maximum.
- 2) Wet Screen Analysis
 - a) Residue on U.S. sieve : 200 mesh, 3% maximum
 - b) Residue on U.S. sieve : 325 mesh, 5% minimum

10. SPECIFICATIONS FOR MEDIUM PEA GRAVEL

Pea gravel conforming to the following specifications. Pea gravel in size of 4.762 mm \times 7938 mm (3/16 in. \times 5/16 in.) free from impurities such as shale, clay, sand, dirt, organic material having hardness not less than 5 Moh's scale. The gravel should be passed through completely from 8.00 mm standard sieve and must be completely retained on 4.762 mm standard sieve.

11. SPECIFICATIONS FOR AIR COMPRESSOR

Portable Air Compressor, capacity 156 m³/min (550 cfm) free air discharge at a working pressure of 17.6 kg/cm² (250 psi) coupled with diesel engine of adequate horse power through clutches, complete with compressor, oil cooler, engine radiator, air receiver-cum-oil separator tank, fuel tank, electric starter and dynamo, batteries, gauges, control panel and set of standard tools. The compressor and engine together with various components, complete unit should be mounted on a suitable trailer all steel welded sturdy frame. The trailer should be fitted with adequate number of pneumatic wheels and should be complete

with draw-bar, hand brakes and remote control brakes. The plant should be provided with a metal sheet canopy with folding doors and locking arrangements.

12. SPECIFICATIONS OF LIGHTENING SETS

3.5 KVA single phase hand start diesel generating set comprising of:

1) ENGINE

The diesel engine should be an air-cooled, single cylinder vertical four stroke cycle, hand start developing 6 bhp at 1500 rpm conforming to BS 5649/IS-1601/1960. It should be fitted with fly wheel and complete with standard accessories, tools etc., engine should be capable of providing an output of 10 per cent in excess of the rated bhp at the speed for one hour in any period of 12 hours consecutive running.

2) ALTERNATOR

3.5 KVA alternator, a.c. supply, single phase unity power factor, having 50 cycles per second suitable for operation on 230/240 volts at 1500 rpm. The alternator should have screen protected/drip proof enclosure and conform to BS: 2613-1970-IS-4722: 1963 with specifically effective ventilation system, safe drip proof enclosure dynamically balanced.

3) GENERATOR ARRANGEMENTS

The engine and alternator will be directly coupled to each other by means of robust flexible coupling and mounted on a common M.D. Channel fabricated base plate.

4) CONTROL PANEL

Control panel box should be mounted on a frame consisting of the following:

- 1) 1 No. voltmeter —Voltmeter selector switch
- 2) 1 No. Ammeter —Ammeter seictor switch
- 3) 1 No. Main Switch —
- 4) 1 No. HRC Fuse
- 5) 1 No. Pilot Lamp

All the above components should be properly mounted to

make them stable against vibration. Suitable terminals should be provided for incoming and outgoing connection with selector switches.

13. SPECIFICATIONS, TERMS AND CONDITIONS FOR MUD PUMP STEEL LINER 6" FOR HEAVY DUTY ROTARY RIG

1) Mud pump liners 152.40 mm (6 in.) inner diameter have to be fabricated out of alloy steel with high carbon contents made equivalent to EN-9 steel as per drawing enclosed.

2) The liners have to be case hardened up to 55-60 hardness Rock-well C Scale. The depth of hardness should be 2 to 3 mm minimum. Liners will have internally honed and externally ground finished to size.

3) Tolerance on ID will be allowed only in plus side up to 0.05 mm. Tolerance will be allowed ± 1 mm in O.D.

4) These liners are to be manufactured from steel. Supplier has to produce composition certificates of the manufacturer when demanded. Right for rejection of material used is reserved in case original certificate as stated above is not produced.

5) The liners should be painted on inside and outside surfaces with anti-rust compound of best trade quality.

SPECIFICATIONS FOR 4½" DRILL COLLARS

- | | | |
|-------------------------------|---|---|
| 1) Outside diameter | : | 4½ in. (112 mm) |
| 2) Length | : | 20 ft. (6 metres) |
| 3) Bore | : | 2¼ in. (56 mm) |
| 4) Top end | : | (82.5 mm) 3¼ in. API—Internal Flush Box |
| 5) Bottom end | : | (89 mm) 3½ in. API—Internal Flush Box |
| 6) Weight per feet (.3 metre) | : | 50 lb per ft (22.6 kg per .3 metre) |

Specifications for Rotary-cum-Down the hole hammer (DTH) drilling rig equipped with air compressor, hydraulic system and mud pump etc. suitable for drilling in hard rock formations like granite, gneisses, decan trap (basalt) schists etc. and also in overburden soils and loose alluvial formations.

The rig should generally conform to the following specifications:

Section I

1) CAPACITY

The rig should be capable of drilling $6/6\frac{1}{2}$ in. (152.4 mm/165 mm) diameter hole to a depth of 305 m (1000 ft) with $4\frac{1}{2}$ in. O.D. (114 mm) drill rods in hard rock by DTH attachment.

The rig should also be able to drill through overburden soils and in loose, alluvial formations by direct rotary mud circulation to a depth of 1500 ft (457 metre) with $4\frac{1}{2}$ in. O.D. (114 mm) drill rods and hole size $8\frac{1}{2}$ in. (216 mm).

2) MOUNTING

The rig should be mounted on a suitable self-propelled truck chassis with adequate capacity and built-up cabin so as to withstand the load of various components of rig such as mast, air compressor, mud pump, hydraulic system motor and other accessories and should be so constructed as to have mobility in negotiating hilly terrains and cross-country roads. The tenderers should stand guarantee for passing the rig from transport authority.

3) MAST

The mast of the rig should be heavy, strong and sturdy structural steel construction, electric welded with sufficient number of cross members for maximum strength so as to withstand safe working load of not less than 3000 kg (30 tonnes). The length of the mast should be about 10.7 m (35 ft) and should be capable of handling 20 ft long (6 metre) drill pipe and casing pipe in a most efficient way. It should be provided with 90° tilt arrangements, operated by two hydraulic jacks (cylinders). The mast should be in horizontal position when the rig is in transit and vertical when drilling.

The mast should be raised and lowered by means of 2 Nos. double acting hydraulic cylinders and should be provided with safety check on hydraulic line fittings to protect against the failure of the hydraulic system.

The mast should be provided with suitable ladder for climbing over top of the mast and indicating needle for purpose of correct levelling of the mast.

4) HYDRAULIC SYSTEM

The hydraulic power devices provided with the rig should be of adequate capacity for efficient operation of various functions of rig such as top head drive, pull-down/down-feed arrangements, hoisting arrangements, raising and lowering of mast etc. It should be controlled with microfeed arrangements to give longer life to the hammer and hammer bit used in drilling. For smooth and safe operation, necessary control valves and pressure valves should be provided.

5) PULL-DOWN

The pull-down system should be equipped with slow/rapid feed valves which provide the driller with a positive control at all times and also in varying strata conditions. Also it should be ensured that the required weight is maintained on the bit while drilling. The pull-down load should be around 16,500 kg (36,000 lb) with selective slow and fast speeds and feed length of approximately 22 ft (6.7 metres).

6) HOISTING ARRANGEMENT

The rig should be provided with hoisting arrangements powered by air/hydraulic motor, having adequate capacity for handling casings, drill pipes during the drilling operation. The hoisting arrangements should have selective slow/rapid speeds.

7) ROTARY HEAD

Hydraulically operated top drive rotary head manufactured from best quality steel, equipped with train of gears running in totally enclosed oil bath, driven through hydraulic motor should be provided. To connect the delivery of the compressor to the spindle for drilling operation, necessary swivel accessories should also be provided. The rotary head should have variable speed, i.e., 0 to 100 rpm with a torque of 50,000 inch lb with a thrust load of 35,000 lb (15855 kg).

8) ROD STORAGE

A circular rod storage rack should be fitted with rig for storage of 5 to 6 numbers of $4\frac{1}{2}$ in. (114 mm \times 6 metre) O.D. 20 ft long drill rod on the machine. The rack should pivot

on its centre axis and can be rotated manually at 360° in either direction. Necessary arrangements for holding the drill rods safely during transportation may be provided.

9) DUST COLLECTOR

A centrifugal type dust collecting system driven through an adequate size and capacity of motor mounted on the rig for dust separation should be provided. Necessary water/foam injection system of suitable capacity and pressure may also be provided.

10) MUD PUMP

The rig should be provided with a reciprocating type mud pump having discharge capacity of about 1000 litres per minute at 250 psi (17.6 kg/cm²). The mud pump should have independent clutch control and should be coupled with a diesel engine of adequate capacity mounted on truck/trailer.

11) AIR COMPRESSOR

The air compressor provided with a rig should be two stage screw rotary type capable to deliver free air discharge of 750 cfm (21m³/mm) at 250 psi (17.6 kg/cm²) at sea level.

The compressor unit should be coupled and powered by water cooled diesel engine of adequate capacity with an ample reserve power when operating under normal temperature and pressure conditions. The unit should be preferably mounted on the same truck chassis and should be equipped with receiver, fuel tank, diesel, transferring hand pump, automatic pressure control, pressure and temperature gauges etc.

12) LEVELLING JACKS

To give maximum stability to the rig during drilling operation, the rig should be provided with 3 nos. of levelling and supporting heavy duty hydraulic jacks.

13) BREAK OUT WRENCHES

For quick and easier coupling or uncoupling of the tool joints, the hydraulic break out wrench at the convenient location on the rig frame may be provided. The rig should be provided with a lighting facilities for night work operation, i.e., electric wiring on the mast, control, frame with lighting lamps.

14) CONTROLS

All the controlling levers, brakes and clutches may be provided at the convenient place for easy and quick accessible approach for the driller.

15) MAINTENANCE EQUIPMENT

The rig should have at least one large tool box made of heavy gauge steel sheet, complete set of hand tools for the maintenance of rig and engine, puller sets, special tools, general purpose tools for operation.

Section II

DTH drilling equipment tools, rotary drilling equipment comprising of the following (all tool joints to API specifications and other authentic standards which ensure an equal or higher quality) should be provided.

1) MAINTENANCE TOOLS

a)	Mechanic tools kit (major)	1 Kit
b)	14 in. (355 mm) pipe wrench (with 4 sets of spare jaws)	1 No.
c)	24 in. (609 mm) pipe wrench (with 4 sets of spare jaws)	2 Nos.
d)	36 in. (914 mm) —do—	2 Nos.
e)	48 in. (1218 mm) —do—	2 Nos.
f)	Chain tongs 24 in. size (609 mm)	2 Nos.
g)	Chain tongs 36 in. size (914 mm)	2 Nos.
h)	Chain tongs 48 in. size (1218 mm)	2 Nos.

2) OPERATING EQUIPMENT FOR DTH DRILLING RIG

a)	DTH Hammer suitable for 250 psi and size 6 in./8½ in. (152/165 mm)	4 Nos.
b)	—do— 8 in./8½ in. (203/216 mm)	2 Nos.
c)	Button bits 6 in. size (152 mm)	50 Nos.
d)	—do— 6½ in. size (165 mm)	25 Nos.
e)	—do— 8/8½ in. (203/216 mm)	10 Nos.
f)	Rock roller for hard formation 7½ in. size with API pin connection	20 Nos.
g)	—do— 8½ in. size (216 mm)	20 Nos.
h)	—do— 12¼ in. size (411 mm)	10 Nos.

- | | | | |
|--------------------------------|--|------------------------------------|---------------------|
| i) | —do— | 13 $\frac{1}{4}$ in. size (336 mm) | 10 Nos. |
| j) | —do— | 17 $\frac{1}{2}$ in. size (444 mm) | 5 Nos. |
| k) | Drill rods 4 $\frac{1}{2}$ in. (114 mm) O.D. API thread connection (both) | | |
| l) | Subs for connection of bit size 7 $\frac{5}{8}$ in., 8 $\frac{1}{2}$ in., 12 $\frac{1}{4}$ in., 13 $\frac{1}{4}$ in., 17 $\frac{1}{2}$ in., 18 $\frac{1}{2}$ in. (193.6, 216, 265, 336, 444, 470 mm) with drill rods and drill collars | | 2 Nos.
each size |
| m) | Bit breakers for 6 in., 6 $\frac{1}{2}$ in. and 8 $\frac{1}{2}$ in. (152, 165, 216 mm) DTH bits | | 2 Nos. each |
| 3) CASING ELEVATORS LINKS | | | |
| a) | 35.36 cm (14 in.) OD casing | | } 1 set each |
| b) | 32.38 cm (12 $\frac{1}{4}$ in.) OD casing | | |
| c) | 27.30 cm (10 $\frac{1}{4}$ in.) OD casing | | |
| d) | 21.91 cm (8 $\frac{5}{8}$ in.) OD casing | | |
| e) | 11.43 cm (4 $\frac{1}{2}$ in.) OD drill pipes | | |
| 4) SLIPS COMPLETE WITH BUSHING | | | |
| a) | 35.26 cm (14 in.) OD casing | | } 1 set each |
| b) | 32.38 cm (12 $\frac{1}{4}$ in.) OD casing | | |
| c) | 27.30 cm (10 $\frac{1}{4}$ in.) OD casing | | |
| d) | 21.92 cm (8 $\frac{5}{8}$ in.) OD casing | | |
| e) | 16.83 cm (6 $\frac{5}{8}$ in.) OD casing | | |
| f) | 11.43 cm (4 $\frac{1}{2}$ in.) OD drill pipes | | |
| 5) | Drill collar 6 $\frac{5}{8}$ in. \times 10 ft. (168 mm \times 3 metre) long. | | 2 Nos. |
| 6) | —do— 8 in. \times 10 ft. (203 mm \times 3 metre) long | | 2 Nos. |
| 7) | Fishing die overshot for 4 $\frac{1}{2}$ in. (114 mm) OD drill pipes | | 1 No. |
| 8) | Fishing tap for 4 $\frac{1}{2}$ in. (114 mm) OD drill pipes | | 1 No. |
| 9) | Fishing magnet | | 1 No. |
| 10) | Pneumatic grinder for button bits | | 2 Nos. |
| 11) | Swivel type lifting bail for drill pipe size 4 $\frac{1}{2}$ in. (114 mm) OD | | 2 Nos. |
| 12) | Suction hole for mud pump [25 ft (7.6 metre) long] | | 2 Nos. |

- 13) Mud mixer 1 in. (25 mm) size 25 ft long
(7.6 metre) 2 Nos.
- 14) Complete mud testing kit 1 No.
- 15) Mud pump delivery hose 2 Nos.
- 16) Double tube core barrels size $4\frac{1}{4}$ in. \times
20 ft (108 mm \times 6 metre) long with cutters
and core catcher assy and core bit. 1 No.

	<i>Amount</i>	
	<i>Rs.</i>	<i>P.</i>
vi) Running of welding set for 60 hrs. @ 7 litres of H.S.D. consumption per hour = 420 litres	1200.00	
vii) Running of air compressor for 100 hrs @18 litres per hour = 1800 litres	5400.00	
viii) Development and testing with V/T Pump for 500 hrs with consumption of 6 litre per hour = 3000 litres	9000.00	
ix) Running of generating set and water pump for 300 hrs and 1 litre per hr = 300 litre	900.00	
x) Movement of jeep/station wagon for selection of site, inspection of work and distribution of pay etc. LS	880.00	
xi) Lubricant for item (i) to (x) 15%	6702.00	
xii) Stock and storage charges 4% (say)	1540.00	
Total	<u>52922.00</u>	
 II. Repairs and Replacement of Parts		
i) Repairs and maintenance of vehicles	4000.00	
ii) Repair and servicing of rig air compressor, water pump and lightening Set L.S.:	2000.00	
iii) Replacement of fast moving parts liners, pistons, rubber cups L.S. :	<u>8000.00</u>	
iv) Stock and storage charges 4% (say)	320.00	
Total	<u>8320.00</u>	
 III. Well Assembly		
i) 14 in. housing pipe 50 mtrs @ Rs. 460	23000.00	
ii) 8 in. slotted pipe 3/64 in. (1.19 mm) 60 m @ Rs. 260	15600.00	
iii) 8 in. blank pipe 140 mtrs @ Rs. 190	<u>26600.00</u>	
	65200.00	
iv) Stock and storage 4% say :	2608.00	
Total	<u>67808.00</u>	
 IV. Miscellaneous Stores		
i) Bentonite power 12 M/T @ Rs. 500	6000.00	

	<i>Amount</i>	
	<i>Rs.</i>	<i>P.</i>
ii) Pea gravel 2000 cft @ Rs. 300 per 100 cft.	6000.00	
iii) Cost of electrodes and gases L.S.	2000.00	
	<u>14000.00</u>	
iv) Stock and storage 4%	560.00	
	<u>14560.00</u>	
Total		<u>14560.00</u>

V. Bits and Tentages

i) Cost of drilling bits	5000.00	
ii) Cost of tents tarpaulins	3000.00	
	<u>8000.00</u>	
iii) Stock and storage 4%	320.00	
	<u>8320.00</u>	
Total		<u>8320.00</u>

VI. Labours

i) Pay of 15 Nos. Work Charged Helpers for 1½ @ Rs. 500 P.M. per W/C Helper	11250.00	
ii) T.A. for 15 Nos. W/C Helpers for 1½ @ Rs. 210 P.M.	3150.00	
iii) Pay and T.A. for 5 Nos. W/C Helpers for development and testing of tubewell @ Rs. 1000 per W/C Helper LS.	5000.00	
	<u>19400.00</u>	

Abstract

	<i>Amount</i>
I) P.O.L.	52922.00
II) Repairs and replacement of parts	8320.00
III) Well assembly	67808.00
IV) Miscellaneous stores	14560.00
V) Bits and tentages	8320.00
VI) Labour	19400.00
	<u>171330.00</u>
VII) Contingency charges 3% (Say) Rs.	5139.00
	<u>176469.00</u>
(Say) Total : Rs.	<u>176470.00</u>

(Rs. One lakh, seventy-six thousand, four hundred and seventy only)

ESTIMATE

Estimate No. : Deposit work no.....1982-83
 Province : _____
 Name of work : Construction.....
 Estimated cost : Rs.....
 Estimate framed by :
 Head of account :

REPORT

The tentative estimate has been framed as per letter No.....
dated... .. of the

The following assumptions were made for preparing the estimate in view of the drilling and hydrogeological conditions in the area.

- 1) The drilling rig unit will be transported from.....and back to.....for further deployment.
- 2) All drilling materials (mud, well assembly etc.) will be transported from to the actual drilling site.
- 3) 10 in. diameter pilot hole of 200 metres deep will be drilled below ground level. Pilot hole will be reamed to 24 in. diameter, 60 metres deep and remaining depth will be reamed to 16 in. diameter.
- 4) The following well assembly will be lowered.
 - 1) 356 mm diameter housing pipe ... 60 mts.
 - 2) 203 mm diameter blank pipe ... 80 mts.
 - 3) 203 mm diameter 3 mm slotted pipe ... 60 mts.
- 5) The well will be gravel packed.
- 6) Cement seals will be provided to seal saline zone.
- 7) The well will be developed both by air compressor and vertical turbine pumps and test for discharge will be done, in case the static water level is within 40 metres. And if water level is beyond 40 metres then the development and testing of the well will be undertaken by the staff of this office provided vertical turbine pump with accessories is supplied by the-----
- 8) The Govt. agency does not give any assurance with regard to the yield and quality of water of the tubewell. It will

make efforts to minimise the eccentricity of the well to the extent possible depending upon the hydrogeological conditions. No guarantee about the quality of the water can be given. However, the State Govt. may indicate in general the quality standards acceptable to them depending upon the area and their consideration.

- 9) The cost derived is temporary and liable to change if there is unavoidable increase in the cost of materials, labour or statutory regulations of the Govt. of India. The actual cost of the well will be found only after the completion of the well and costing will be done as per actual expenditure. The party will pay the actual cost of difference of the actual expenditure of the construction of the well if it exceeds the estimated cost.
- 10) Drilling and reaming hire charges Rs. 16.40 per metre has been charged as per Govt. rules.
- 11) Departmental charge @ 13.75% has been charged on the total cost as per Govt. rules.
- 12) The well will be abandoned in case hard formations are encountered where drilling by rotary rig is not possible and all the cost incurred to shift the rig and drill up to the formation until the well is abandoned has to be borne by the party.

Sd/-
incharge
Govt. Agency

TERMS AND CONDITIONS REGARDING CONSTRUCTION OF DEPOSIT TUBEWELLS BY (Govt. Agency)

Party indicates: 'A'

1) The party will pin point the sites for the tubewells in advance and furnish a map showing the location of tubewells sites to enable Govt. Agency to plan its operation.

2) The party will be responsible for the provision of the approach road to the tubewell sites, for taking the drilling equipment to the site. If the tubewell site is on private land, the party should arrange for no objection certificate for carrying out the drilling work. No claim on account of damage to crops

compensation for damage or land etc. will be entertained by a Govt. Agency.

3) The Govt. Agency will require suitable building accommodation for storage of P.O.L. spare parts etc. and open space for stocking pipes, gravel etc. and suitable place in the area of operations. The party should either provide the so facilities or assist the Govt. Agency in arranging for them.

4) The Govt. Agency does not give any assurance regarding to the yield and quality of water from a tubewell. The party should however, indicate well in advance the minimum and maximum yield in I.G.P.H. required by it corresponding for the guidance of Govt. Agency the different chemical constituent in water will be acceptable to it.

5) The tubewell will be developed by Govt. Agency until the stabilisation and gravel pack is completely assured. The tolerable unit of sand content in the final discharge is 10 parts of sand in one million parts of water by volume collected after 20 minutes of starting the tubewell.

6) The design of the tubewell as determined by the Govt. Agency will be final. The party should post a responsible technical officer to work in close liaison with the Govt. Agency and in particular to give a decision on the spot about additional drilling that may be advisable beyond the depth for which the estimate is prepared, as it will not be possible to wait for the approval of the party when drilling is in progress. He should also be present at the final testing of the wells which may last up to 6 hrs. The tubewell should be taken over by the party as soon as the tests are complete.

7) The tolerable limit of eccentricity so far as the housing pipe is concerned will be 2 in. in 100 ft in case of 12 in. housing and 4 in. in 100 ft in case 14 in. housing pipe is used.

8) The Govt. Agency is working on the C.P.W.D. system of accounting. No guarantee to complete the work within the estimated amount can be given. The actual expenditure incurred plus departmental and hire charges at the rate prescribed from time to time will be debited to the party as per standing rules.

9) The strata as well as strata chart showing pipe assembly lowered will be furnished to the party.

10) The pumping set will be procured and installed by the party.

Sd/-
Govt. Agency

The above terms and conditions are acceptable to the party.

Signature

GOVERNMENT AGENCY

2. ESTIMATE FOR THE CONSTRUCTION OF ONE EXPLORATORY TUBEWELL IN HARD ROCK AREA BY D.T.H. RIG

Drilling Depth: 100 metres H.S.D. Rate Rs. 3 per litre (old rate)
Petrol Rate Rs. 6 per litre

- | | | |
|------------------------|---|-----------|
| i) Rotary Drilling | : | 60 metres |
| ii) Hard Rock Drilling | : | 40 metres |

Amount
Rs.

I. P.O.L.

- | | |
|--|---------|
| i) Shifting of rig and ancillary equipment from previous site to proposed site H.D. truck 4 trips of 400 km to and fro 1600 km. Average consumption of H.S.D. @ 4 km per litre=400 litres | 1200.00 |
| ii) Shifting of camp equipment and staff from previous site by medium duty truck to and fro 4 trips of 400 km : 1600 km. Average consumption of H.S.D. @ 5 km per litre=320 litres | 960.00 |
| iii) Movement of vehicles for shifting of pipes, mud and miscellaneous store from base camp to site by medium duty truck to and fro 4 trips of 800 km=3200 km. Average consumption of H.S.D. @ 5 km per litre=640 litres | 1920.00 |
| iv) Movement of vehicles for shifting of gravel P.O.L., gases etc. from Base camp to site by medium duty truck to and fro 3 | |

	<i>Amount</i> Rs.
trips of 800 km=2400 km. Average consumption of H.S.D. @ 5 km per litre = 480 litres.	1440.00
Water hauling from near by source by medium duty truck at an average distance of 10 km to and fro for 100 trips per well with an average consumption of H.S.D. 4.5 km per litre	600.00
v) Fuel for rig and mud pump engines, assuming rig to work for 20 hrs per day for 7 days with a consumption of H.S.D. 12 litres per hr both engines = $20 \times 7 \times 12 = 1680$ litres	5040.00
vi) Running of welding set for 20 hrs @ 7 litres of H.S.D. consumption per hour = 140 litres	420.00
vii) Running of heavy duty 250 psi air compressor for 60 hrs @ 60 litres per hour = 3600 litres	10800.00
viii) Development and testing with V/T Pump for 100 hrs with consumption of 6 litres per hour = 600 litres	1800.00
ix) Running of generating set and water pump for 100 hrs @ 1 litre per hr = 100 litres	300.00
x) Movement of jeep/station wagon for selection of site, inspection of work and disbursement of pay etc. 3 trips of 800 km each to and fro @ 6 km per litre consumption = 400 litres	2400.00
xi) Lubricant for item (i) to (x) @ 15%	4032.00
xii) Consumption of detergent (Foam) oil in Hard Rock Drilling = 10 litre @ Rs. 200/ litre	2000.00
Total	<u>32912.00</u>
 II. Repairs and Replacement of Parts	
i) Repairs and maintenance of vehicles LS	2000.00
ii) Repair and servicing of rig, air com-	

pressor, water pump and lightening set (L.S.)	2000.00
iii) Replacement of fast moving parts, liners, pistons, rubber cups (L.S.)	1000.00
	<u>5000.00</u>
Stock and storage charges @ 5%	250.00
Total	<u>5250.00</u>
 III. Well Assembly	
i) 8 in. housing pipe 40 mtrs. @ Rs. 190	7600.00
ii) 8 in. slotted (1/16 in.) pipe 20 m @ 260	5200.00
	<u>12800.00</u>
Stock and storage charges @ 5%	640.00
Total	<u>13440.00</u>
 IV. Miscellaneous Stores	
i) Bentonite powder 2 M/T @ Rs. 500	1000.00
ii) Pea gravel 200 cft @ Rs. 300 per 100 cft	600.00
iii) Cost of electrodes and gases LS	1500.00
	<u>3100.00</u>
Stock and storage charges @ 5%	155.00
Total	<u>3255.00</u>
 V. Bits and Tentages	
i) Cost of drilling bits	6000.00
ii) Cost of tents tarpaulines	2000.00
	<u>8000.00</u>
Stock and storage charges @ 5%	400.00
Total	<u>8400.00</u>
 VI. Labour	
i) Pay of 15 Nos. Work Charged Helpers for 15 days @ Rs. 500 p.m. per W/C Helper	3750.00
ii) T.A. for 15 Nos. W/C Helpers for 15 days @ Rs. 140 p.m.	1050.00
iii) Pay and T.A. for 5 Nos. W/C Helpers for 15 days for development and testing of tubewell @ Rs. 640 per W/C Helper	1600.00
Total	<u>6400.00</u>

Abstracts

I) P.O.L.		32912.00
II) Repairs and replacement of parts		5250.00
III) Well assembly		3440.00
VI) Miscellaneous stores		3255.00
V) Bits and tencages		8400.00
VI) Labour		6400.00
	Total	<u>69657.00</u>
Contingency charges @ 3%		2089.00
	Total Rs.	<u>71746.71</u>

**3. ESTIMATE FOR CONSTRUCTION OF DEPOSIT
TUBEWELLS BY DIRECT ROTARY**

Drilling Depth: 250 metres H.S.D. Rate Rs. 3.00 per litre
(old rate)

Petrol Rate Rs. 6.00 per litre

Amount

Rs. P.

I. P.O.L.

- | | |
|---|----------|
| i) Shifting of rig and ancillary equipment from previous site to proposed site by H.D. truck, 5 trips of 800 km to and fro 4000 km. Average consumption of H.S.D. @ 4 km per litre = 1,000 litres | 3000.00 |
| ii) Shifting of camp equipment and staff from previous site, 4 trips of 800 km = 3200 km. Average consumption of H.S.D. @ 5 km per litre = 640 litres. | 1920.00 |
| iii) Movement of vehicles for shifting of pipes, mud and miscellaneous store from Base Camp to site. | |
| iv) Movement of vehicles for shifting of gravel P.O.L., gases etc. from Base Camp to site. L.S. (iii) & (iv) | 1000.00 |
| v) Fuel for rig and mud pump engines, assuming rig to work for 20 hrs per day for 20 days with a consumption of H.S.D. 12 litres per hr both engines = $20 \times 12 \times 20 = 4800$ litres | 14400.00 |

	<i>Amount</i>	
	<i>Rs.</i>	<i>P.</i>
vi) Running of welding set for 60 hrs @ 7 litres of H.S.D. consumption per hr. = 420 litres		1260.00
vii) Running of air compressor for 60½ hrs. @ 18 litres per hour = 1080 litres		3240.00
viii) Development and testing with V/T pump for 300 hrs with consumption of 6 litre per hour = 1800 litres		5400.00
ix) Running of generating set and water pump for 250 hrs @ 1 litre per hrs = 250 litres.		750.00
x) Movement of jeep/station wagon for selection of site, inspection of work and disbursement of pay etc. L.S.		500.00
xi) Lubricant for item 1 to 10 @ 15%		4720.00
xii) Stock and storage charges @ 4%		1448.00
Total		<u>37638.00</u>

II. Repairs and Replacement of Parts

i) Repairs and maintenance of vehicles :	2000.00
ii) Repair and servicing of rig, air compressor, water pump and lightening set. L.S.	1500.00
iii) Replacement of fast moving parts, liners, pistons, rubber cups L.S.	2000.00
Total :	<u>5500.00</u>
Stock and storage charges @ 4%	220.00
	<u>5720.00</u>

III. Well Assembly

i) 14 in. housing pipe 50 mtrs @ Rs. 460	23000.00
ii) 8 in. slotted 3/64 in. pipe 60 mtrs @ Rs. 260	15600.00
iii) 8 in. blank pipe 140 mtrs @ Rs. 190	26600.00
Total Rs.	<u>65200.00</u>
Stock and storage charges @ 4%	2608.00
Total	<u>67808.00</u>

		<i>Amount</i>	
		<i>Rs.</i>	<i>P.</i>
IV. Miscellaneous Stores			
i)	Bentonite powder 10 M/T @ Rs. 500	5000.00	
ii)	Pea gravel 1500 cft. @ Rs. 300 per 100 cft.	4500.00	
iii)	Cost of electrodes and gases	L.S. 2000.00	
	Total	<u>11500.00</u>	
	Stock and storage charges 4%	460.00	
		<u>11960.00</u>	
V. Bits and Tentages			
i)	Cost of drilling bits	2000.00	
ii)	Cost of tents and tarpaulines	3000.00	
	Total	<u>5000.00</u>	
	Stock and storage charges 4%	200.00	
		<u>5200.00</u>	
VI. Labours			
i)	Pay of 15 Nos. Work Charged Helpers for 1½ months @ Rs. 500 per month per W/C Helper	11250.00	
ii)	T.A. for 15 Nos. W/C Helpers for 1½ months @ Rs. 210 p.m.	3150.00	
iii)	Pay and T.A. for 5 Nos. W/C Helpers for development and testing of tubewell @ Rs. 1000 per W/C Helper LS.	5000.00	
		<u>19400.00</u>	
 <i>Abstract</i>			
		<i>Amount</i>	
		<i>Rs.</i>	<i>P.</i>
I)	P.O.L.	37638.00	
II)	Repairs and replacement of parts	5720.00	
III)	Well assembly	67808.00	
IV)	Miscellaneous stores	11960.00	
V)	Bits and tentages	5200.00	
VI)	Labour	19400.00	
	Total	<u>147726.00</u>	

	<i>Amount</i>	
	<i>Rs.</i>	<i>P.</i>
VII) Contingency charges @ 3%	4432.00	
VIII) Departmental charges 13 $\frac{3}{4}$ %	20920.00	
IX) Hire charges @ 16.40 per metre of drilling/reaming :		
250 + 750 = 1000 × 16.40	=	<u>16400.00</u>
Total		<u>189478.00</u>
Say		<u>189500.00</u>

4. ESTIMATE FOR CONSTRUCTION OF EXPLORATORY TUBEWELL BY D.T.H.

Drilling Depth 100 metres H.S.D. Rate Rs. 3 per litre
 Petrol Rate Rs. 6 per litre

	<i>Amount</i>	
	<i>Rs.</i>	<i>P.</i>
I. P.O.L.		
i) Shifting of rig and ancillary equipment from previous site to proposed site by H.D. truck 5 trips of 800 kms to and fro 4000 km Average consumption of H.S.D. @ 4 km per litre = 1000 litres	3000.00	
ii) Shifting of camp equipment and staff from previous site 4 trips of 800 km = 3200 km Average consumption of H.S.D. @ 5 km per litre = 640 litres.	1920.00	
iii) Movement of vehicles for shifting of pipes mud and miscellaneous store from Base Camp to site.		
iv) Movement of vehicles for shifting of gravel.P.O.L. gases etc. from Base Camp to site (iii & iv) L.S.	1000.00	
v) Fuel for rig and mud pump engines. Assuming rig to work for 20 hrs per day for 15 days with a consumption of H.S.D. 12 litres per hr both engines = 20 × 15 × 12 = 3600 litres	10800.00	
vi) Running of welding set for 40 hrs @ 7		

	<i>Amount</i>
	Rs. P.
litre of H.S.D. consumption per hour = 280 litres	840.00
vii) Running of air compressor for 50 hrs @ 18 litres per hour = 900 litres	2700.00
viii) Development and testing with V/T pump for 300 hrs with consumption of 6 litre per hour = 1800 litres	5400.00
ix) Running of generating set and water pump for 250 hrs @ 1 litre per hr = 250 litres	750.00
x) Movement of jeep/station wagon for selection of site, inspection of work and disbursement of pay etc. L.S.	1000.00
xi) Lubricant for item (i) to (x) @ 15%	4110.00
xii) Stock and storage charges @ 4%	1260.00
Total	<u>32780.00</u>
 II. Repairs and Replacement of Parts	
i) Repairs and maintenance of vehicles	2000.00
ii) Repair and servicing of rig, air com- pressor, water pump and lightening set L.S.	2000.00
iii) Replacement of fast moving parts liners, pistons, rubber cups L.S.	2000.00
	<u>6000.00</u>
Stock and storage charges @ 4%	240.00
	<u>6240.00</u>
 III. Well Assembly	
i) 14 in. housing pipe 50 mtrs @ Rs. 460	23000.00
ii) 8 in. slotted (3/64 in. slot) pipe 20 m @ Rs. 260	5200.00
iii) 8 in. blank pipe 30 mtrs. @ Rs. 190	5700.00
	<u>33900.00</u>
Stock and storage charges @ 4%	1356.00
Total	<u>35256.00</u>
 IV. Miscellaneous Stores	
i) Bentonite powder 8 M/T @ Rs. 500	4000.00

	<i>Amount</i>
	<i>Rs. P.</i>
ii) Pea gravel 1000 cft @ Rs. 300 per 100 cft	3000.00
iii) Cost of electrodes and gases L.S. :	1500.00
	<u>8500.00</u>
Stock and storage charges @ 4%	340.00
Total	<u>8840.00</u>
 V. Bits and Tentages	
i) Cost of drilling bits	2000.00
ii) Cost of Tents and tarpaulines	2000.00
	<u>4000.00</u>
Stock and storage charges @ 4%	160.00
Total	<u>4160.00</u>
 VI. Labour	
i) Pay of 15 Nos. Work Charged Helpers for one month @ Rs. 500 p.m. per W/C Helper	7500.00
ii) T.A. for 15 Nos. W/C Helpers for one month @ Rs. 140 p.m.	2100.00
iii) Pay and T.A. for 5 Nos. W/C Helpers for development and testing of tubewell @ Rs. 700 per W/C Helper	3500.00
Total	<u>13100.00</u>
 <i>Abstract</i>	
I) P.O.L.	32780.00
II) Repairs and Replacement of Parts	6240.00
III) Well Assembly	35256.00
IV) Miscellaneous Stores	8840.00
V) Bits and Tentages	4160.00
VI) Labour	13100.00
Total	<u>100376.00</u>
VII) Contingency Charges 3% Say Rs.	3010.00
Total	<u>103386.00</u>
Say Rs. 1,03400.00	

**5. ESTIMATE FOR CONSTRUCTION OF DEPOSIT
TUBEWELL BY PERCUSSION RIG**

Drilling Depth = 110 Metres

HSD Rate Rs. 2.60
Per Litre (old rate)

I. P.O.L.

- | | |
|---|----------|
| i) Shifting of rig and ancillary equipment from previous site to proposed site | |
| ii) Transportation of camp equipment of staff miscellaneous stores to site LS 1+ii | 1000.00 |
| iii) Movement of vehicles for shifting of pipes and misc. stores from Base Camp to place of work 6 trips of 400 km to and fro = 2400 km. Average consumption of HSD @ 5 km per litre = 480 litres | 1248.00 |
| iv) Shifting of gravel, P.O.L. gases etc. from Base Camp to place of work 12 round trips of 400 km per trip = 4800 km. Average consumption of fuel @ 5 km per litre = 960 litres | 2496.00 |
| v) Shifting of drive pipes from Base Camp to place of work 10 round trips of 400 km each = 4000 km. Consumption of HSD @ 5 km per trip = 800 litres | 2080.00 |
| vi) Running of welding set for 150 hours for bit dressing and lowering of well assembly, making shoe cutters etc. Average consumption of HSD @ 7 litres per hour = 1050 litres. | 2730.00 |
| vii) HSD for running of rig engine for 200 shifts of 8 hours each. Average consumption of HSD @ 10 litres per hour. Total consumption of HSD = $200 \times 8 \times 10 = 16000$ litres. | 41600.00 |
| viii) Consumption of HSD for running of water pump for 200 hrs @ 1 litre per hour = 200 hrs | 520.00 |
| ix) Running of air compressor for 50 hours | |

consumption of HSD @ 16 litres per hour=800 litres			2080.00
x) Movement of jeep/station wagon for inspection disbursement of payment, pin-pointing of site etc. 12 trips of 400 km each=4800 km. Average consumption of petrol @ 5 km per litre=960 litres Rate of petrol Rs. 5.50 per litre			5280.00
xi) Running of vertical test pump for 300 hrs @ 6 litres per hour=1800 litres			4680.00
xii) Lubricants, cotton waste, grease, etc. 15% of above.			9557.00
	Total		<u>73271.00</u>
 II. Repairs and Replacement of Parts			
i) Repairs and maintenance of vehicles LS			3000.00
ii) Repairs and servicing of rigs, air compressor welding set etc. LS			4000.00
	Total		<u>7000.00</u>
 III. Bits and Tentage			
i) Cost of drilling regular bits LS:			5000.00
ii) Cost of tents/tarpaulines LS			5000.00
	Total		<u>10000.00</u>
 IV. Well Assembly			
<u>S. No.</u> <u>Description</u>	<u>Quantity</u> <u>in metre</u>	<u>Rate</u> <u>Rs.</u>	<u>Amount</u> <u>Rs.</u>
1) 12 in. housing	60.00	212/-	12720.00
2) 12 in. slotted size 1/16 in.	25.00	240/-	6000.00
3) 8 in. blank	15.00	150/-	2250.00
4) 8 in. slotted	10.00	175/-	1750.00
	Total		<u>22720.00</u>
 V. Miscellaneous			
i) Cost of electrodes, gases for dressing of bits, well assembly fabrication, shoe-cutters making etc. LS			5000.00

ii) Pea-gravel 1000 cft @ Rs. 210 per 100 cft	<u>2100.00</u>
Total	<u>7100.00</u>

VI. Labour

i) Pay for 10 Nos. Work Charged Helpers @ Rs. 450 per helper p.m. for six months	27000.00
ii) TA/DA for 5 Nos. Work Charged Helpers @ 1000 per helper for development of testing	5000.00
iii) TA/DA for 10 Nos. Work Charged Helpers for six months @ Rs. 150 per month	9000.00
iv) Wages for 10 Nos. Casual labourers for 3 months for extraction of casing pipes @ Rs. 250 per month per casual labourer	<u>7500.00</u>
Total	<u>48500.00</u>

Abstract

<u>S.No.</u>	<u>Sub-Head</u>	<u>Amount</u> <u>Rs.</u>
I)	POL	73270.00
II)	Repairs and Replacement of Parts	7000.00
III)	Bits and Tentage	10000.00
IV)	Well Assembly	22720.00
V)	Miscellaneous	7100.00
VI)	Labour	<u>48500.00</u>
	Total	168590.00
VII)	Contingency Charges @ 3%	5057.73
VIII)	Departmental Charges 13 $\frac{3}{4}$ %	23876.00
IX)	Hire Charges @ 16.40 per metre of drilling 110 × 16.40 = Rs. 1804.00	<u>1804.00</u>
	Total	<u>199328.00</u>

Say: Rs. 1,99,330

(Rupees one lac ninety nine thousand three hundred and thirty only)

Table A: Conversion for Volume

Unit	Equivalents							
	Cu in.	Gal	Imperial gal	Cu ft	Cu yd	Cu m	Acre-ft	Sfd
Cubic inch	1	0.00433	0.00361	5.79×10^{-4}	2.14×10^{-5}	1.64×10^{-5}	1.33×10^{-8}	6.70×10^{-9}
US gallon	231	1	0.833	0.134	0.00495	0.00379	3.07×10^{-6}	1.55×10^{-6}
Imperial gallon	277	1.20	1	0.161	0.00595	0.00455	83.68×10^{-6}	1.86×10^{-6}
Cubic foot	1,728	7.48	6.23	1	0.0370	0.0283	2.30×10^{-6}	1.16×10^{-6}
Cubic yard	46,656	202	168	27	1	0.765	6.20×10^{-4}	3.12×10^{-4}
Cubic metre	61,000	264	220	35.3	1.31	1	8.11×10^{-4}	4.09×10^{-4}
Acre-foot	7.53×10^{-7}	3.26×10^{-5}	2.71×10^5	43,560	1610	1230	1	0.504
Second, foot-day	1.49×10^9	6.46×10^5	5.38×10^5	86,400	3200	2450	1.98	1

Table B: Conversion for Discharge

Unit	Equivalents						
	Gpd	Cu ft/day	Gpm	Imperial gpm	Acre-ft/day	Cfs	Cu m/sec
U.S. gallon per day	1	0.134	6.94×10^{-4}	5.78×10^{-4}	3.07×10^{-6}	1.55×10^{-6}	4.38×10^{-8}
Cubic foot per day	7.48	1	5.19×10^{-3}	4.33×10^{-3}	2.30×10^{-5}	1.16×10^{-5}	3.28×10^{-7}
U.S. gallon per minute	1,440	193	1	0.833	4.42×10^{-3}	2.23×10^{-3}	6.31×10^{-5}
Imperial gallon per minute	1,728	231	1.20	1	5.31×10^{-3}	2.67×10^{-3}	7.57×10^{-5}
Acre foot per day	3.26×10^6	43,560	226	188	1	0.504	0.0143
Cubic foot per second	6.46×10^6	86,400	449	374	1.98	1	0.0283
Cubic metre per second	2.28×10^7	3.05×10^6	15,800	13,200	70.0	35.3	1

Table C
MISCELLANEOUS PHYSICAL CONSTANTS
CONVENIENT HYDRAULIC EQUIVALENTS

1 hp=0.746 kw=550 ft-lb/sec

1 millibar=0.0143 psi

1 sec-ft-day/sq mi=0.03719 in.

1 in. of runoff per sq mi=26.9 sec-ft-days=53.3 acre-ft

1 cfs=0.9917 acre-in/hr

1 United States gallon of water weighs 8.34 pounds.

1 cubic foot of water weighs 62.5 pounds.

1 second-foot=7.48 United States gallons per second=
 448.8 United States gallons per minute=26,929.9 United States
 gallons per hour=646,317 United States gallons per day.

1 second-foot=60 cubic feet per minute=3,600 cubic feet per
 hour 31,536,000 cubic feet per year=0.000214 cubic mile per year.

1 second foot=0.9917 acre-inch per hour=1,983471 acre-
 feet per day=723.966942 acre-feet per year.

1 second foot=50 miner's inches in Idaho, Kansas, Neb-
 raska, New Mexico, North Dakota, and South Dakota=40
 miner's inches in Arizona, California, Montana, and Oregon=
 38.4 miner's inches in Colorado.

1 second-foot=0.028317 cubic metre per second=1.699
 cubic metre per minute=101.941 cubic metre per hour=2,446.58
 cubic metre per day.

1 cubic metre per minute=0.5886 second-foot=4.403 United
 State gallons per second=1.1674 acre-feet per day.

1 million gallons per day=1.55 second-feet=3.07 acre-feet
 per day=2.629 cubic meters per minute.

1 second-foot falling 8.81 feet=1 horsepower.

1 second foot falling 10 feet=1.135 horsepower.

1 second-foot falling 11 feet=1 horsepower, 80 per cent efficiency.

1 second-foot for 1 year (365 days) will cover 1 square mile 1.13 feet or 13.5744 inches deep.

1 inch deep on 1 square mile=2,323,200 cubic feet=0.0737 second foot for 1 year.

1,000,000,000 (1 United States billion) cubic feet=11,570 second feet for one day=386 second-feet for one 30 day month =372 second-feet for one 31 day month.

100 California miner's inches=18.7 United States gallons per second=4.96 acre-feet in one day.

100 Colorado miner's inches=2.60 second feet=19.5 United States gallons per second=5.17 acre-feet in one day.

100 United States gallons per minute=0.223 second foot=0.442 acre-feet in one day.

1 foot head of water=0.434 pound pressure on 1 square inch.

Bibliography

1. Agriculture Deptt. *Brochure on drilling equipment*, Ministry of Food and Agriculture, Government of India, New Delhi, 1968.
2. Agriculture Deptt., USA *The Year Book of Agriculture 1955*. Oxford & IBH Publishing Co., New Delhi, 1969.
3. Anderson, K.E. *Water Well Hand Book*. The Missouri Water Well Driller Association, Rolla Missouri, U.S.A., 1964.
4. Brantley, J.E. *Rotary Drilling Hand Book*. Palmer Publication, 25 West, 45th Street, New York, 1961.
5. Baroid, N.L. "*Fluid Testing of Drilling Muds*". N.L. Baroid, N.L. Industries Inc., P.O. Box 1675, Houston, Texas 77001.
6. Campbell, Michael D. *Water Well Technology*. McGraw-Hill Book Co., New York, 1973.
7. Central Water Power Commission, Ministry of Irrigation "*Tapping underground water by different types of drilling rigs*". New Delhi, 1969.
8. Garg, Satya Parkash *Groundwater and Tubewells*. Oxford and IBH Publishing Co., New Delhi, 1978.
9. Gatlin, C. *Petroleum Engineering Drilling and Well Completion*. Prentice-Hall Inc., Englewood Cliffs, NJ, 1960.

10. Geological Survey of India *Economic Geology Vol. 54, 1959 Ground Water Provinces of India*, pp. 697-883.
11. Gibson, P. *Small Wells Manual*. Department of State Agency for International Development, Washington D.C., U.S.A., 1969.
12. Gogelkar, D.V. Dr. *Irrigation Research in India*. Publication, 78 Central Board of Irrigation & Power, New Delhi.
13. Heiland *Geophysical Exploration*. Prentice-Hall Inc., New York, 1980.
14. Ingersoll-Rand Co. *New T-4 Drill Water Catalogue*. Ingersoll-Rand, Rock Drill Division, New York.
15. International Development Research Centre *Rural Water Supply in China*. International Development Research Centre, 60 Queen Street, Ottawa, Canada, 1981.
16. Jain, J.K. *Hand Book of Boring and Deepening of Wells*. Ministry of Food & Agriculture, New Delhi, 1962.
17. Johnson, E.E. *Ground Water and Wells*. Edward E. Johnson Inc., Saint Paul, Minnesota, USA, 1966.
18. Melray & Cole *Oil Well Drilling Technology*. University of Oklahoma, Norman Oklahoma, USA, 1973.
19. National Water Well Association *Well Drilling Manual*. Koehring, Speedstar Division Enid Oklahoma, USA, 1980.
20. Rogers, F. Water *Computation on Properties of Oil Well Drilling Fluids*—Gulf Publishing Co., Houston, Texas USA, Third edition, 1963.
21. Sanwal, K.D. *Hand Book on Tubewells*. Superintendent, Printing and Stationery, UP (India), Allahabad, 1951.
22. Todd, D.K. *Ground Water Hydrology*. John Wiley & Sons, 1959.

23. University of Roorkee *Proc. International Seminar on Development and Management of Ground Water Resources.* University of Roorkee (India), 1979.
24. Volney C. Finch *Pump Hand Book.* The National Press, Palo Alto, California, USA, 1967.

- R.R. 93
 - Blasting 103, 117
 - Bore hole 13, 76, 105
 - Break-out tongs 43
 - Bridging 91, 111
 - Brushing 113, 115
 - Bullreel 34
- C
- Cable tool/percussion drilling 12, 20, 35
 - Caliper log 76, 79
 - Calyx Drill 72
 - Capstan 13
 - Casing 117
 - Cavernous limestone 101
 - Caving 102, 162
 - Cavities 101, 103, 104
 - Cement grout 106
 - Cement material 103
 - Cement sealing 104
 - seal 106
 - Cementation 2
 - Chemical treatment 101, 103, 115
 - Choice of equipment 17
 - H.P. rating rig engine 74
 - rig mounting 74
 - Circular orifice plate method 128
 - Cleavage 5
 - Clogged 111, 115
 - Clogging 101
 - Combination rig 14
 - Comparison rotary/percussion 16
 - Compressed air 13, 60, 100, 111, 150
 - Compression of aquifer 3
 - Compressor 13, 60, 98, 99, 100, 101, 103, 107, 111, 139, 143, 150, 152, 153
 - Conductivity (hydraulic) 3
 - Construction of well 13
 - Conventional camera 10
 - map 10
 - studies 10
 - Corrosion 85, 158, 163
 - resistance material 147
 - Corrosive 83, 85
 - Cost 85, 158
 - Cost of equipment 17
 - Current electrode 11
- D
- Darcy law 119, 121
 - Density 20, 26
 - Deposit Lacustrine 5
 - Derrick 164, 165
 - Detonating 12, 117
 - Deviate 61
 - Discharge head 144
 - pressure 142
 - rate measurements 127
 - test 122
 - V-notch tables 130
 - Drainage courses 10
 - density 10
 - pattern 9
 - system 10
 - Drawdown 8, 13, 99, 100, 101, 111, 113, 123, 130, 139, 148
 - Test 122
 - Draw works (Rotary) 45
 - (Reverse) 56
 - Drill collar (rotary) 41, 47
 - cutting 20, 42, 47, 100, 162, 163
 - Drill pipe 61, 110, 115, 139
 - stem 37, 47
 - test 130, 140
 - Drill string D.T.H. 60
 - percussion 35
 - reverse 56, 57
 - rotary 41, 43, 45
 - Drilling fluid 20, 33, 58, 60, 71, 163
 - jar collar 36
 - performance 19
 - Drills air-cum-percussion 72
 - combination 14, 16, 17, 109
 - diamond 72
 - D.T.H. 14, 15, 17, 72
 - percussion 13, 15, 16, 17, 109
 - reverse 14, 72
 - rotary 14, 15, 16, 17, 72, 109
 - Drop pipe 150, 152, 153, 157
 - Dyke 10
 - Dynamite charge 12, 117

E

- Eccentricity 89, 90
- Eduction pipe 150, 151, 153
- Electrically logged/logging 13, 63, 91, 100, 137
- Elevator 50
- Entrance velocity 82
- Equipment/accessories 50
 - (miscellaneous) rig 56
- Erosion 163
- Erosional features 9
- Evaporation 1
- Exploration 54
 - ground water 8
- Exploratory drilling 12

F

- Factors governing selection pump 148
- Fatigue 27, 47, 163
- Faults 9
- Field tests 3
- Filtration properties (wall building test) 30
- Fish tail bit 48
- Fishing 162
 - taps releasing, non-releasing 164
 - tools 40, 162, 163
 - tools (cable) 54, 166, 167, 168
 - tools (rotary) 54, 163, 164, 165, 166
- Fissures 9, 10, 103, 117
- Flow charts (a-e) 21, 22, 23
- Fluid loss 27
 - pressure 119
- Fluvial features 10
- Foam drilling 67, 68, 69
- Foliation 5
- Formation clay and shale 48
 - clayey 5
 - fissured 54
 - geological 4, 12
 - impermeable 2
 - massive 100
 - non-caving alluvial 14
 - permeable 2

- porous 1, 54
- rock 1, 13
- sandy 13
- water bearing 42, 100
- Fractures 2, 10, 113, 115, 117

G

- Gel strength (shear) 27, 30, 33
 - 10 minutes (funnel viscosity) 30, 33
- Geological mapping 9
- Geomorphological features 9
- Geomorphology 5
- Geophysical logging 70
 - methods 8, 11
 - survey 11
 - technique 11
- Generating set 147
- Granite terrain 9
- Gravel envelope 19, 89
 - pack 9, 89, 91, 92, 101
 - packed artificially 85, 86
 - packed properties 88
 - packed well 110
 - packing 13, 86, 92
- Gravitation 1
- Gravity 3
- Ground water chemical quality 1
 - development 9
 - exploration 11, 13
 - hydraulic 119
 - investigation 12
 - level 6
 - resources evaluation 9
 - studies 10
 - system 108

H

- Hammer 60, 61, 63
 - bit 94
 - tool 93
- Hard rock 100, 103, 104, 117
 - aquifer 124
- Head column 150
- High head 145
- Hoist lines 33

- of the strata 13
- Sand analysis curve 83
 - content 27, 30
 - free 13, 93, 109, 110, 118, 157
 - line 33
 - pump 37
- Sand stones horizon 6
- Saturation 3
- Scaffolding 149
- Screen 101, 105, 110, 113
- Screen opening 86
- Sediments 6
- Seepage 5
- Seismic vibration 12
- Self-potential (SP) 76, 77
- Sensors 10
- Settling pit 26
- Shaft 43
- Sheaves 44, 50
- Shock absorber 35
- Shooting 113, 116
- Shovelling action 48
- Shrouded 91, 92
- Sieve analysis 83
 - sizes 84
- Sieves 89
- Single point resistance 76, 77
- Sink hole 10
- Sinker jar 36
- Slips 53
- Slot size 89
- Slotted pipes 13, 84, 91, 92, 93, 102, 113
- Sloughing 26, 31, 67, 102, 103
- Solution cavities 2
 - channel 104
- Slug test 97
- Slush pit 59
- Sodium hexametaphosphate 33, 103
- Soil 1
- Soil thick 10
- Soil water 1
- Sounding 93, 105
 - line (rod) 106
- Specific capacity 82, 112, 148, 149
 - gravity, 28, 37
 - retention 3
- yield 3
- Specifications 26
 - air compressor 194
 - barytes powder 194
 - combination drill 173
 - direct rotary 184
 - drill collar 196
 - drilling mud 193
 - lightening set 195
 - mud pump liner 195
 - Pea-gravel 194
 - rotary-cum-DTH 196
 - slot perforator 190
 - slotted pipe 172
 - steel wire rope 192
 - submersible pump 192
 - turbine pump 191
- Spring 6, 9
- Sprockets 43
- Spudder machine 20, 33
- Spudding 33
- Stand pipe hose 52
- Static water level 149
- Step drawdown test 122
- Sticking up of rod 31
- Sticking up of string 33
- Storage 3
- Storage coefficient 3, 126
- Storavity 13
- Strainer well 71
- Strata 13, 49, 80, 93, 139
- Stratigraphic boundary 12
- Stratigraphic control 8
- Strength requirement 85
- Structural control 8
 - situation 6
- Submergence 152
 - starting 150, 153
- Submersible motor 145, 146, 147
- Sub-soil 1
- Substitute joint 48
- Suction hose 52
- Surge block 10
 - plunger 103
- Surging 110, 118
- Surging tool 110
- Swabbing tendency 30
- Swivel 50, 56

Swivel hose 52

T

Technique depth sounding 11

drilling 15

Telescopic well structure 82

Terrain 19

Terrain limestone 10

Test assembly 138, 139

drilling 11, 12, 13, 69

site 12, 14

Textures 9

Theim method 125

Thixotrophy 29

Tonal changes 9

contrast 10

Tool cable 20

joint 46, 52

Topographical 6

Topography 1

Torque 47, 52

Transmissivity 3, 13, 100, 123,

126, 140

Transpiration 1

Travelling block 50, 58

Tungston carbide 48

U

Uniformity coefficient 89

V

Viscosity 28, 29

Viscous fluid 74

Viscous mixture 26

V-notch 128, 129

Volume conversion 222

W

Wash back of tool 169

Wash over pipe 169

Water bearing properties 9

Water level 9, 13, 103, 104, 121

contour map 9

deeper 6

shallow 6, 9

table 1, 3, 6, 108, 149

Wedging 162

Well assembly 13, 92

Well casing 82

depth 81, 82

design 81, 100

development efficiency 117

diameter 81, 82

efficiency 83

failure 85

intake 81

life 81

logging 12, 76

Well observation 104, 120, 123,

139

production 101, 113, 115

pumping 139

screen length 81, 82

screen slot opening 81, 83

sick 109, 117

stimulation 115

structure 12, 81

test 17, 91, 121

tube 98, 158

Wells 5, 12, 13

alluvial 9

bore 115

construction 101

development 83, 85, 86, 89, 91,

93, 101

dug 5, 7, 69, 71, 72

dug-cum-bore 7

hard rock 93

logging 12

reverse 93

rotary 91, 113

Weighting material 26, 31

Winch 43

Winch loading system 40

Wire line 17

Wire rope socket 36

Working Submergence 150, 152,

153

Y

Yield 2, 5, 7, 8, 81, 93, 97, 100,

101, 103, 113, 117, 120, 139, 148
Yield potential 5, 6, 7
Yield prospects 7

Z

Zones of areation 1
aquifer 12
brackish water 19

capillary 1
confining clay 92
fissured cavernous 71
intermediate 1
phreatic 1
saturation 1
water bearing 11
weathered 1, 10, 11

