

Water from Roads

A handbook for technicians and farmers
on
harvesting rainwater from roads



During rainy days, the road from Kitui to Kibwezi functions both as a river and a road.

The result of the dual function is that gullies damage both the road and adjacent farmland.



Rainwater run-off from the Nairobi-Mombasa highway is diverted into an earth dam at Salama, which provides water for livestock, brick-making and forestry without any erosion.

Erik Nissen-Petersen
for
Danish International Development Assistance (Danida)
2006

213.1.06WA-109074

Water from Roads

**A handbook for technicians and farmers
on
harvesting rainwater from roads**

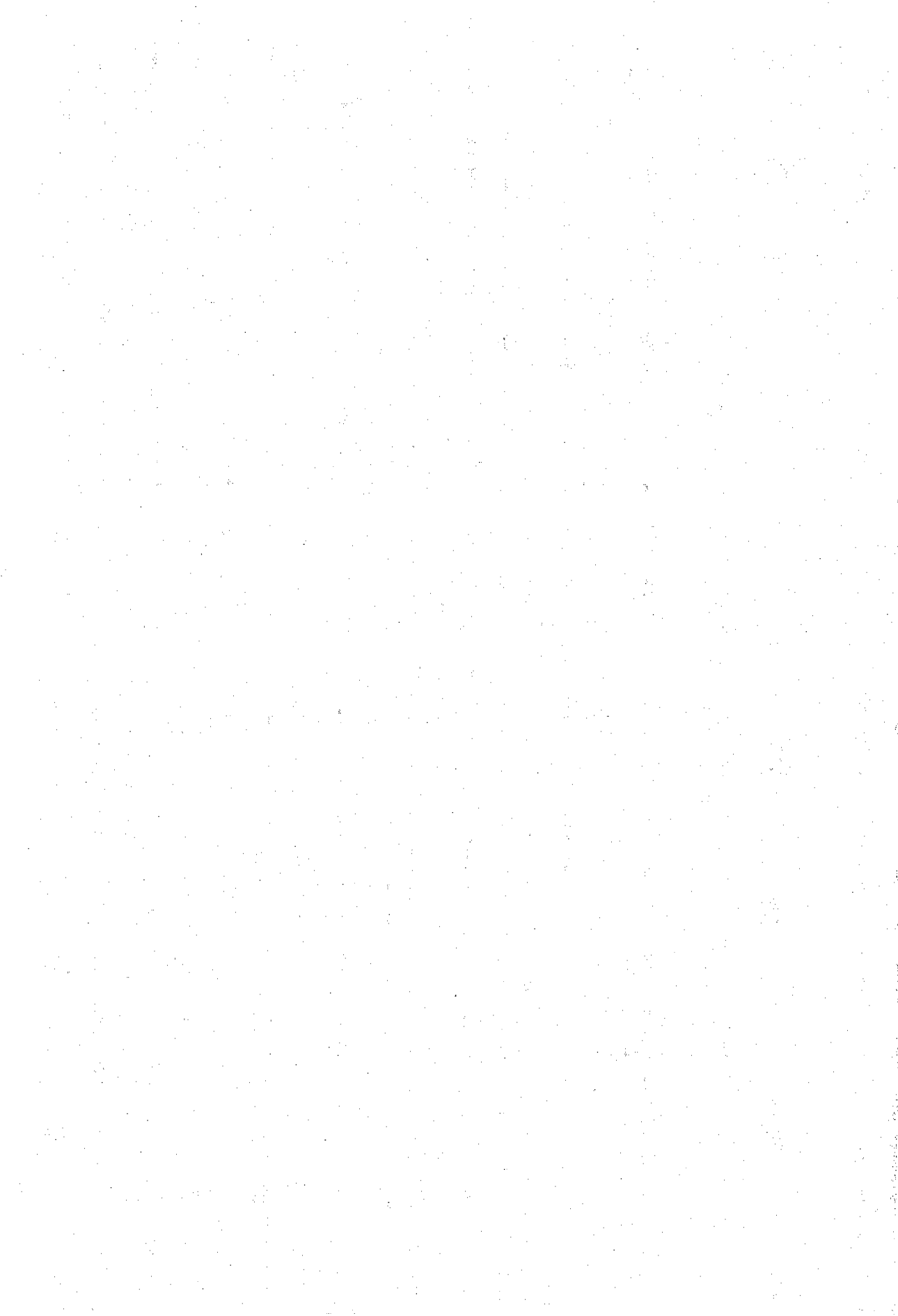

Water from Roads

**A handbook for technicians and farmers
on
harvesting rainwater from roads**



During rainy days, the road from Kitui to Kibwezi functions both as a river and a road.



The result of the dual function is that gullies damage both the road and adjacent farmland.



Rainwater run-off from the Nairobi-Mombasa highway is diverted into an earth dam at Salama, which provides water for livestock, brick-making and forestry without any erosion.

Erik Nissen-Petersen
for
Danish International Development Assistance (Danida)
2006



Technical handbooks in this series :

Titles

Water for rural communities
Water supply by rural builders
Water surveys and designs
Water from rock outcrops
Water from dry riverbeds
Water from roads
Water from small dams
Water from roofs

Contents

Lessons learnt from Kitui pilot projects
Procedures for being rural contractors
Survey, design and cost of water projects
Rock catchment tanks, masonry and earth dams
Wells, subsurface dams, weirs and sand dams
Rainwater harvesting from roads
Ponds and small earth dams built manually
Various types of roof catchments for domestic use

These handbooks can be obtained free of charge by either collecting them from the office of ASAL Consultants Ltd., or by paying through bank transfer the cost of sending the manuals by courier. For further details, please contact: asal@wananchi.com with copy to asalconsultants@yahoo.com

Published by

ASAL Consultants Ltd. for
the Danish International Development Assistance (Danida) in Kenya

Text, sketches and photos by
Erik Nissen-Petersen

Computer drawings by
Catherine W. Wanjihia

Editing and proofs by
Prof. Elijah K. Biamah, Amin Verjee and Steen S. Larsen

Printer
Printwell Ind. Ltd., P.O. Box 5216-0506, Nairobi, Kenya

Website by
Edwin Ondako

Distribution by
ASAL Consultants Ltd. P.O. Box 739, Sarit 00606, Nairobi, Kenya
asal@wananchi.com asalconsultants@yahoo.com
Fax/Tel : 254 020 2710296 and 4766144 Mobiles: 0733 619 066 and 0722 599 165
Website : www.waterforaridland.com

Copyright.

The copyright of this handbook is the property of the Royal Danish Embassy in Kenya. Downloading from the internet and photocopying of the handbooks is permitted provided the source is acknowledged.

Contents

Page

Acknowledgement	vii
Foreword	viii
Technical vocabulary	ix
Measurements and conversions	x
Chapter 1. Damage by road run-off water	1
1.1 Road damage by run-off	1
1.2 Loss of people and livestock	2
1.3 Gullies made by culverts	3
1.4 Volume of rainwater running off roads	4
1.5 Benefits from rainwater running off roads	5
Chapter 2. Earth dams	6
2.1 Murram pits	6
2.2 Small pans	8
2.3 Large pans	8
2.4 Ponds	9
2.5 Charco dams	9
2.6 Hillside dams	10
2.7 Valley dams	11
2.8 Tools and equipment for soil works	12
2.9 Analysis of soil samples	13
2.10 Construction costs of earth dams	14
2.11 References on earth dams	14
Chapter 3. Water tanks	15
3.1 Advantages of water tanks	15
3.2 Excavation of hemispherical tanks	15
3.3 Hemispherical tank built of burnt bricks	16
3.4 Hemispherical tank built of ant-hill soil, lime, sand and cement	19
3.5 Hemispherical tank built of ferro-cement	23
3.6 Cylindrical underground water tanks	26
3.7 Berkads	28
3.8 Rectangular water tanks	33
3.9 References on water tanks	33
Chapter 4. Subsurface dams	34
4.1 Water in sand reservoirs	34
4.2 Floodwater passing roads	34
4.3 Hand-dug wells	35
4.4 Subsurface dams, weirs and sand dams	36
4.5 Subsurface dams built of soil	37
4.6 Weirs	39
4.7 Sand dams	40
4.8 Sand harvesting	44
4.9 Gold and gem stones from sand dams	45
4.10 References on subsurface dams, weirs and sand dams	45
Chapter 5. Run-off farming	46
5.1 Drainage from roads by engineers	46
5.2 Drainage from roads by farmers	47
5.3 Soil bunds	50
5.4 Gullies	51
5.5 Macro-irrigation	55
5.6 References on run-off farming	57

Acknowledgments

Much gratitude is due to Birgit Madsen of the Royal Danish Embassy in Nairobi for having taken a leading role in documenting the experiences of various techniques of creating low-cost water supply structures in the semi-desert, arid and semi-arid regions of the world.

Many thanks are also due to Prof. Elijah Biamah, Steen Larsen and Amin Verjee, who assisted with proof-reading the text and editing, to Edwin Ondako who created the website and loaded this handbook and others onto it, and to Oliver D'Cunha, who managed the printing at Printwell Ind.Ltd..

Thanks are also due to the many engineers, technicians, artisans and self help groups who participated in several training courses and other assignments on small earth dams implemented by ASAL Consultants Ltd. for Danida, SIDA, UNDP, the EU and other organisations in a dozen countries over the last three decades.

This handbook, *Water from Roads*, is one of a series of 8 publications on *Water in Arid Lands*, financed by the Danish International Development Assistance (Danida).

To promote the simple technologies described in the handbooks, these can be read or downloaded free of charge from our website www.waterforaridland.com.

Erik Nissen-Petersen
Managing Director
ASAL Consultants Ltd.
P.O. Box 739, 00606, Nairobi, Kenya
Tel/fax: +254 (0)20 2710296
Mobile: +254 (0)733 619066 / +254 (0)722 599144

Disclaimer

The designs and construction procedures described in this handbook are based on the author's experiences and observations over 30 years. The tanks and earth dams described herein, when properly constructed and maintained, have performed exceptionally well. However, local climatic, geological, seismic and soil conditions vary widely, as does the quality of materials and workmanship, and while the author and Danida are keen to encourage the replication of the ponds and dams described in this handbook, they cannot accept liability for the failure of a water harvesting system based on the designs and construction procedures described herein.

Foreword

This handbook on water from roads produced by Danida in Kenya is targeted at all organizations involved in road construction works and especially the Ministry of Roads and Public Works.

Currently, all road construction works have no provision for the storage of run-off water generated from road drainage. This handbook then comes when road engineers have been trained and sensitized on the importance of safe disposal of run-off water from roads.

Water from Roads as a handbook is expected to serve as a guide for road engineers and contractors who are involved in the design and construction of road drainage works. The handbook provides valuable technological advice for harnessing road run-off water.

This handbook provides all the technical information required for the design and construction of all the types of earth dams, water tanks and subsurface dams. Also the handbook contains information on run-off farming.

It is this understanding of the technical information contained herein that our roads could be designed better by providing viable alternative technologies options for harnessing road drainage. This handbook also provides alternative technologies for run-off water utilization.

Mrs Elizabeth Mibey
Principal Environmental Impact Assessment (EIA) Officer
Ministry of Roads and Public Works

TECHNICAL TERMS AND ABBREVIATIONS

ASAL	=	Arid and Semi-Arid Lands
ASALCON	=	ASAL Consultants Ltd.
Batter	=	Gradient of a dam wall
Bench mark (BM)	=	A fixed point for measurements
Berm	=	Area between a reservoir borrow pit and dam wall
Base	=	Foundation for a dam wall
Borrow pit	=	An excavation from where soil is taken
Bill of Quantities (BQ)	=	List of materials and labour, with costing
Catchment	=	Area draining run-off water to a common point
Centre line	=	An imaginary line through the centre of a crest at the upper level of the freeboard
Contour line	=	Horizontal line connecting points of equal altitude
Crawler	=	Bulldozer
Crest	=	Top of dam wall
Danida	=	Danish International Development Assistance
Diaphragm	=	Blanket of soil on upstream side of embankment
Downstream batter	=	Downstream slope of a dam wall
Downstream toe	=	Downstream edge of a dam wall
Draw-off pipe	=	Pipe draining water by gravity
Embankment	=	Dam wall
Evaporation	=	Water lost as vapour from a water surface
EU	=	European Union
Freeboard	=	Safety height of dam wall from maximum water level
Gradient	=	Slope
Hafir (Arabic term)	=	A type of earth dam for livestock and people
Inselberg	=	A massive bare rock outcrop common in the tropics
Impervious	=	Not letting water through
Key (Cut-off trench)	=	Trench of clayey soil to prevent seepage
Live fencing	=	Fence of vegetation, preferably thorny
Murram	=	A clayey soil packed with stones found in laterite soil
NIL	=	Cement slurry
Seepage	=	Water seeping through soil
Sediment	=	Soil deposited in reservoir
Settlement	=	Soil compacting and shrinking due to weight
SIDA	=	Swedish International Development Assistance
Sill	=	Low concrete wall across spillway
Siltation	=	Dam reservoirs being filled with silt
Siphon	=	Pipe lifting water over a high point to a lower level
SODIS	=	SOLar DISinfection (of water)
Spillway	=	Overflow channel discharging excess floodwater
Storage ratio	=	Volume of water in relation to volume of soil
Turbid	=	Muddy, unclear water carrying sediment
Throw-back	=	Length of a reservoir full of water
Topographical	=	Relating to the shape and height of the land
UNDP	=	United Nations Development Programme
Upstream batter	=	Upstream slope of a dam wall
Upstream toe	=	Upstream edge of a dam wall
Valley dam	=	Dam constructed in a valley with a straight embankment
Washout	=	Section of a dam wall washed away by water

ILLUSTRATION OF TECHNICAL TERMS

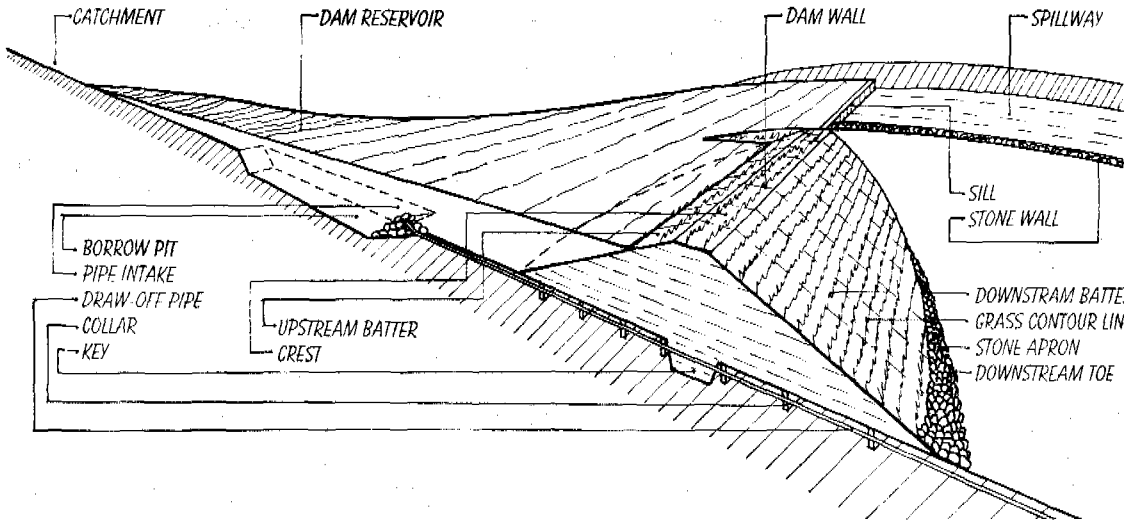

Cut-through section of a three-dimensional sketch of a dam wall.

MEASUREMENTS AND CONVERSIONS

Length	1 metre = 3.28 feet	
	1 km = 0.62 miles	
Area	1 acre = 4,047 m ²	= 0.4047 hectares (ha)
	1 ha = 10,000 m ²	= 2.471 acres
	1 km ² = 100 ha	= 247.1 acres
Volume	1 litre = 1.75 pints	= 0.22 Imp gallons (or 0.26 US galls)
	1 m ³ = 1,000 litres (l)	= 220 Imp gallons (or 260 US gallons)
	1 Imperial gallon	= 4.550 l
	1 US gallon	= 3.785 l
Weight	1 tonne	= 1,000 kg
	1 British ton	= 1,016 kg
	1 US ton	= 907 kg
Volumes and weight of materials	1 m ³ water	= 1,000 kg
	1 m ³ dry soil	= 1,230 to 2,000 kg
	1 m ³ compacted soil	= 2,180 kg, approximately
	1 m ³ loose gravel	= 1,745 kg, approximately
	1 m ³ stones	= 2,400 kg to 2,900 kg

Exchange Rate Used in the Manual

Ksh	= Kenya Shillings
Ksh 72/	= USD 1.00 (October 2006)

Chapter 1. Damage by road run-off water

1.1 Road damage by run-off

Rainy seasons are blessings for farmers but hard times for motorists. Streets get flooded and impassable in towns due to blocked or under-dimensioned sewage systems. In the countryside, villagers may be cut off from the rest of the world due to deep holes filled with water and mud, which vehicles cannot drive through. The photo shows the depth of such a hole in a road after the water has evaporated.



Here the rainwater has cut a small gully on one side of the road. Since usually no repairs take place during rainy seasons, every additional rain shower will make the gully deeper.



The following rain showers have now deepened and widened the small gully into a deep cut that runs halfway across the road and through the farmland until the flood reaches a riverbed.



The rainwater continues to remove considerable amounts of murrum from the road and soil from the farmland, which is eventually transported to the sea via riverbeds, where it chokes fish, coral reefs and damages the marine ecology.

A few more rain showers have now extended the gully right across the road and made it impassable.



The only way of by-passing the gully is to drive over the farmer's land on the higher side of the road, where vehicles have cut a deep track. No crops will ever grow there again.

A road-grader has made a cut-off channel to divert run-off water from a road to a field.

While this preserves the road, it damages the field, because the run-off water will create a gully stretching all the way from the road to the nearest riverbed.

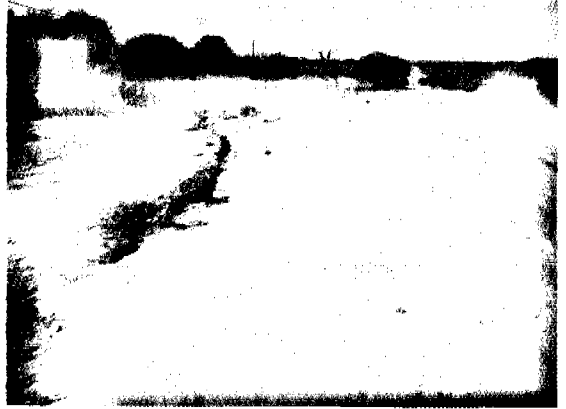

After a few years, the run-off water from the road will have deepened and widened a small gully in a fertile farmland to a bare valley where all the top soil has been eroded. Only hardy thorny scrubs can grow there.

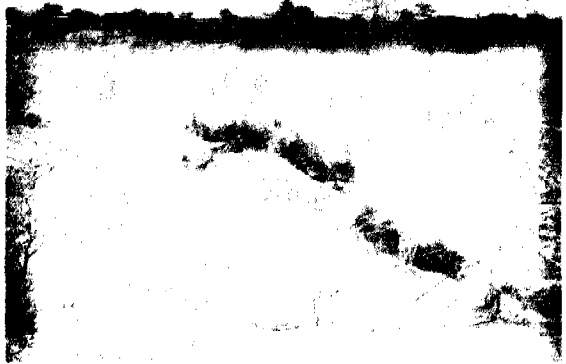

Where no preventive action is taken, a small gully may turn into a desolate moon landscape as seen in the photo.

In this way, thousands of acres of fertile farmland are being washed away every year by uncontrolled rainwater running off roads.



Another hazard created by rainwater running off roads is that some people and animals lose their lives, while trying to cross a road over a riverbed flooded by rainwater.

1.2 Loss of people and livestock

Often rainwater comes as a flash flood several metres high, which carries uprooted trees and drowned animals -- and sometimes drowned people - into the brown maelstrom of flooded riverbeds. The photo shows the damage by erosion to a low bridge after a flood has passed over it.

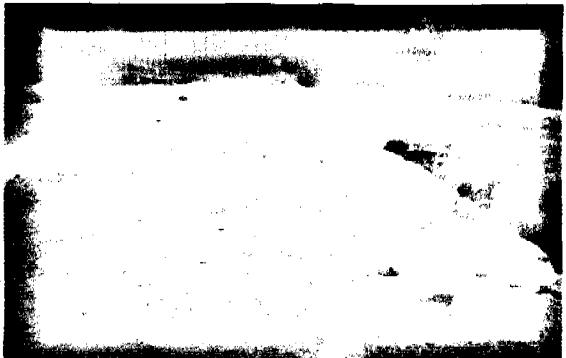

This handbook explains in simple terms, how other people have stopped the erosion process and improved their living standards. 2

1.3 Gullies made by culverts

Culverts are concrete rings laid as drainage pipes under roads at their lowest points. The culverts drain run-off water from the upper side of a road to a riverbed on the lower side of the road.

The photo shows a series of concrete check dams along the newly built Nairobi-Mombasa highway. The check dams reduce the velocity of water before it enters the culvert seen in the left lower corner.



On the other side of the road, the culvert discharges the water into a small ditch which spills the water onto grazing land without any soil protection. This ditch will turn into a deep gully after some rainy seasons and the topsoil and grass will be washed away. In the near future, the Maasai will have to graze their livestock elsewhere.



This photo, of the same road near Sultan Hamud, gives a good impression of the huge volumes of run-off water from roads after a small rain shower.

Luckily, this water is discharged into a riverbed without any erosion.

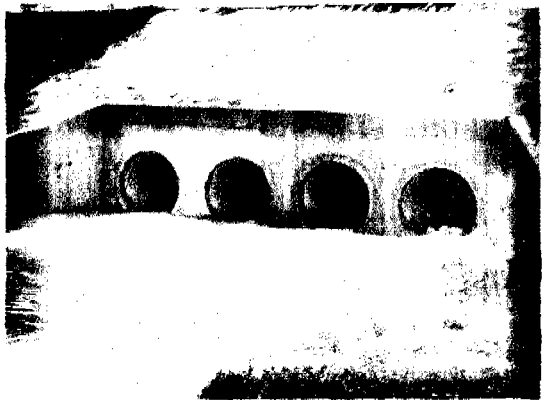

This photo shows a culvert near Arusha that discharges run-off water into a ditch that will either turn into a gully or a riverbed after a few more rainy seasons.



1.4 Volume of rainwater running off roads

The volume of rainwater running off from a 1 km long murram or tarmac road from a rain shower of 30 mm, can be estimated as follows:

Road area: 1,000 m long and 4 m wide
Road surface: Murram or soil
Run-off efficiency: 80%
Rainfall: 30 millimetres

$$\frac{1,000 \text{ m} \times 4 \text{ m} \times 80 \times 30 \text{ mm}}{100} = 96,000 \text{ litres} = \mathbf{96 \text{ cubic metres from 1 km road}}$$

Bearing in mind that the average annual rainfall in a season is about 600 mm in most ASAL regions, the total annual volume of run-off water from a 1 km long murram road is:

$$\frac{1,000 \text{ m} \times 4 \text{ m} \times 80 \times 600 \text{ mm}}{100} = 1,920,000 \text{ litres} = \mathbf{1,920 \text{ cubic metres}}$$

Considering that one local Zebu cow consumes about 20 litres of water in a day, then 185 local cows can be watered every day in a year (1,920,000 litres minus 30% loss (576, 000 litres) = 1,344,000 litres / 20 litres / 364 days = 185) from only 1 km of murram road.

This example shows clearly that roads can supply huge volumes of water for livestock, irrigation, forestry, construction works, etc., provided the harvested water can be stored until it can be used in the following dry season.

If the stored water is intended for domestic use, it can be treated using grounded seed from *Moringa stenopetala* to settle the dirt in the bottom of a container. Thereafter the water should be sterilised either by boiling or by the Sun's ultraviolet rays that can destroy all bacteria in water filled in transparent bottles and exposed to 6 hours sunshine.



Run-off water from the Kanziku road in Kericho has been harvested into this pond, which was made by scooping out a depression and placing the soil as a dam wall on the lower side of the excavation. Hopefully, the woman will treat the water she is drawing, before it will be used for domestic purposes.

1.5 Benefits from rainwater running off roads

As shown on the previous page, the 1,344 cu.m. run-off water from 1 km of road can water 185 local cows every day in a year, while taking into account that 30% of the water may be lost due to evaporation or seepage. Besides watering livestock, the water could also be used for other purposes, such as:

1. Tree nurseries, woodlots, orchards and vegetative fencing of fields and homesteads, which provide income from sale of tree seedlings, timber, firewood, fruits, etc.
2. Manufacturing of burnt bricks, concrete blocks, culverts and other building materials that can be sold.
3. Sale of water to neighbours for watering their livestock, construction works, etc.
4. Raising ducks, geese, fish and bees in or near open water reservoirs.
5. Sale of sand harvested from weirs and sand dams in gullies and riverbeds.
6. Recharge of hand-dug wells near subsurface dams, weirs and sand dams in riverbeds from where domestic water can be drawn.
7. Using run-off water from tarmac roads for domestic use is not advisable due to the risk of contamination by tar, oil, rubber, etc.
8. Increased agricultural production from fields irrigated by road run-off water.

Two examples of school boys earning cash for their schooling:



Harvesting sand for sale from a sand dam built in a gully near Lake Victoria. The construction cost of 10 sand dams was recovered from sale of sand in 1 ½ years.



Assisting water vendors in bringing empty jerrycans to a water point near Voi.

The next chapters will describe four types of rainwater harvesting from roads, namely earth dams, tanks, subsurface dams and run-off farming, which farmers can construct themselves for a minimum of investment.

Chapter 2. Earth dams

The most common technique for harvesting run-off water from roads is to store the harvested water in reservoirs built of soil. The construction cost consists only of labour to excavate and transport soil. There is no need to purchase cement or reinforcement iron from hardware shops.

Several types of soil structures that can be constructed successfully by farmers are described in the following chapters.

2.1 Murram pits

Murram pits, also called **borrow pits**, are always situated along roads and are easy to convert into water reservoirs, because only excavation of one or two trenches is required. However, before digging the trenches, it is advisable to discuss the issue with the local authorities.

Murram pits are found along most roads, because the material (murram) excavated from them is used for building the roads. Whenever a road is re-carpeted with murram, the existing pits are either widened, or new murram pits are excavated.

In any case, the floor of murram pits is usually either impermeable laterite or rock, through which there is hardly any seepage. If the walls or the floor of a murram pit are stony they may allow some seepage but that can be sealed by plastering a mixture of clayey soil and lime onto the leaking parts.



A murram pit along a road in Kitui

The run-off water from a road is diverted into a murram pit by excavating a trench reaching upwards from the murram pit to the ditch running along the road. To prevent sedimentation of the water reservoir in the murram pit, the trench should have a gradient of about 3 cm for every 100 cm.

A gradient of 3:100 can be measured by levelling a spirit level on a 300 cm long timber having a leg being 9 cm long.

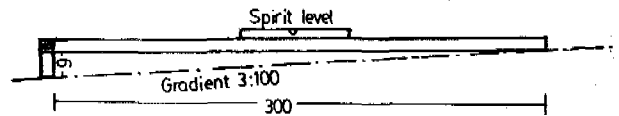

This photo shows a cut-off trench that has been cut by a road grader for the purpose of diverting run-off water from the road into an adjacent field. Similar trenches can be excavated by hand, or ox-scoops, to divert rainwater into murram pits.



When a murrum pit has been filled with rainwater running off a road, the surplus water must be discharged over a spillway to avoid damage to the water reservoir. The height of spillways is important. If a spillway is too low, the maximum storage capacity of the water reservoir is wasted. If a spillway is too high, the lowest part of the wall will not be able to withstand the water pressure and it will be washed away thereby destroying the water reservoir.

Preferably, the surplus water from a filled up murrum pit should pass over a spillway that diverts the water back to its original course of discharge.

In practice, the optimal height of spillways and the discharge of surplus water from murrum pits can be found by heighten the spillway in stages.

Spillways should always be protected by large stones packed with smaller stones into the floor and sides of the spillway to prevent erosion and ensure that the final height of a spillway is maintained.

Water can be drawn from murrum pits in many ways depending on the usage of the water.



The side of a spillway protected by stones



A girl filling jerrycans with water from a murrum pit for domestic use.

Two boys pumping water from a murrum pit for irrigation of vegetables using a Money-maker foot pump costing about Ksh 5,000.



2.2 Small pans

Pans are natural depressions without any dam walls around their water reservoirs. Pans were scooped out by elephants long time ago whereas murrum pits are man made. Local people call these pans *silanga ya ndovu*, meaning elephant dams.

Rainwater running off roads can be diverted into pans by excavated trenches, or along stone bunds, having a gradient of about 3:100 as described above.

A small depression next to a road at Mbuinzau at Kibwezi has been converted into a pan by building a "speed bump" across the road, which diverts run-off water into the pan.

Please note that the downstream side of the pan has been eroded by surplus water due to lack of a spillway covered with stones.



A small pan next to a road at Kibwezi.

2.3 Large pans

Large pans for storage of run-off water from roads and the annual floods from Angola, are common water sources in the extremely flat land of Ovamboland in Northern Namibia. The pans are used for raising fish, watering livestock and domestic uses as well.

Deep pans in the Sudan are called *hafirs*.



An excavated pan in northern Namibia that harvests run-off water from roads.

An old pan being desilted manually in Taveta, for Food-for-Work, apparently without a proper workplan.

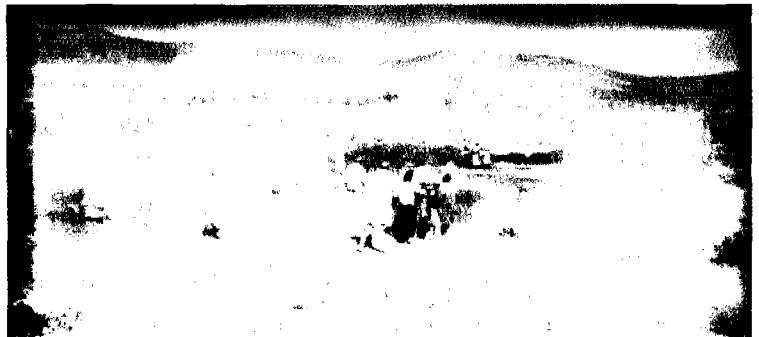

A pan built recently by crawlers in the flat land of Taveta financed by TTAP/Danida.



2.4 Ponds

Ponds are small earth dams that are made by scooping out soil and using the soil to construct a dam wall on the lower side of the water reservoir. There are three main types of small earth dams namely: Charco dams, hillside dams and valley dams. These dams are described in detail in another handbook of this series, namely *Water from Small Dams*, and will therefore only be described briefly in this handbook.

2.5 Charco dams

Charco dams are suitable where run-off from roads spill over onto flat land, preferably with silty or clayey soils. The best design for charco dams resembles a calabash cut in half for scooping and pouring water as shown in the photo below.

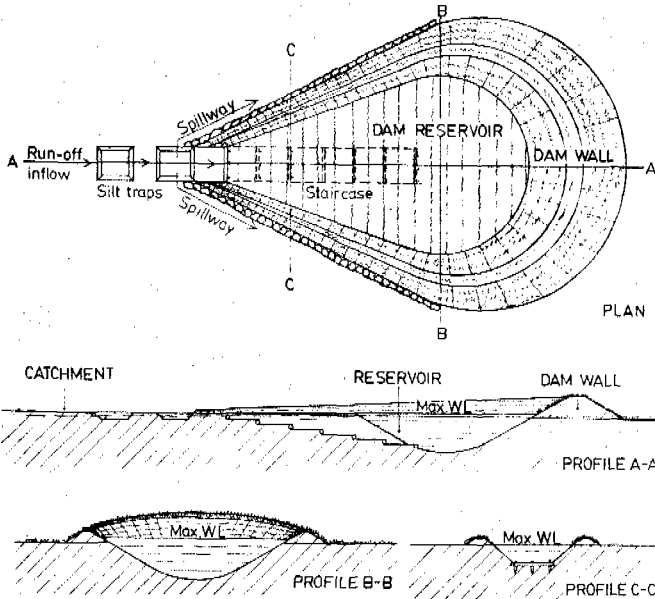

Plan and profiles of a charco dam

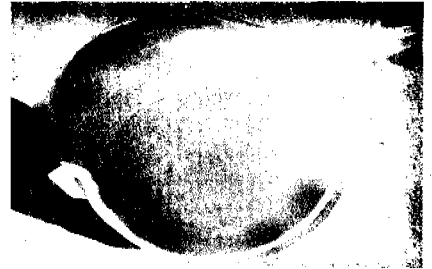

A calabash cut in half.



A charco dam in Tanzania.

Charco dams and other small dams can be constructed in stages during dry seasons, when manual labour is available. Alternatively, neighbours who want to draw water from somebody else's dam can be requested to scoop out and transport one wheelbarrow of soil for every jerrycan of water they want to carry home, or the water can be sold for cash and used to hire contract labourers for deepening a dam.

At every stage, the water reservoir can be made deeper and the dam wall higher from soil excavated from the reservoir. This process can be continued until the dam can hold enough water throughout the year.

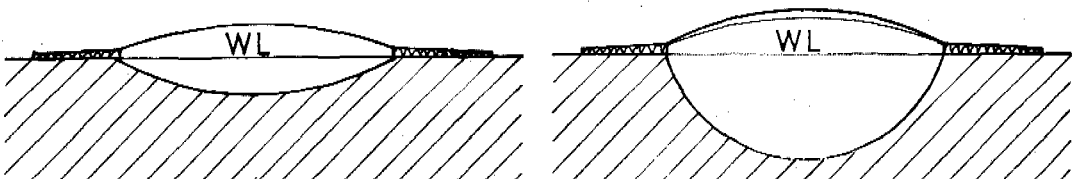

Cross sections of a charco dam showing the first and last stage of excavation works.

2.6 Hillside dams

Hillside dams are suitable where run-off water from roads can be diverted onto sloping land or hillsides. These dams have an oval-shaped water reservoir with a semi-circular dam wall on the lower side of the reservoir.

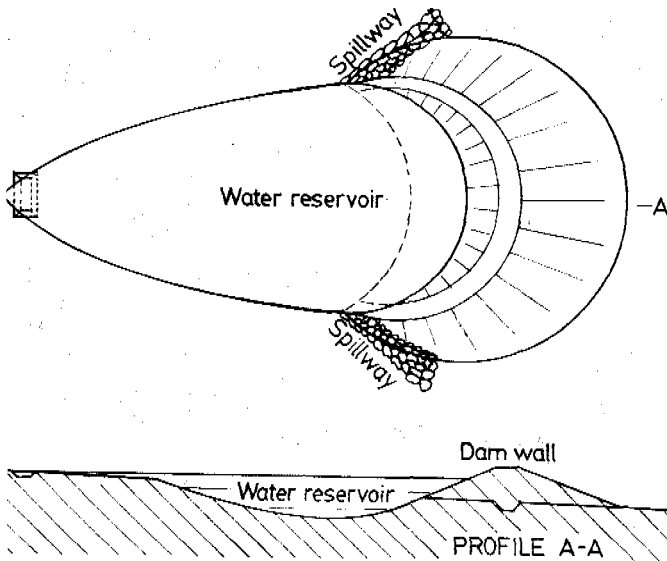

Plan and profiles of a hillside dam.

Hillside dams must have a spillway at each end of the curved dam wall in order to discharge surplus water when the reservoir is full.

The two spillways should be at the same horizontal level in order to discharge surplus water safely. A horizontal line can be sighted along the two water levels in a circular transparent hosepipe filled halfway with water.

Spillways must be reinforced with large stones interplanted with grass at the dam wall to prevent erosion by over-flowing water.

Also the floors of spillways should be covered with stones and grass and interplanted with types of grass having many runners and long roots.



A hillside dam at Lukenya along the Nairobi - Mombasa highway.



Another hillside dam at Salama on the same highway.



Sighting along the two water levels in a circular transparent hosepipe filled halfway with water, gives an exact horizontal line.

2.7 Valley dams

Valley dams are suitable where run-off water from roads is discharged into valleys. Valley dams have straight embankments (dam walls) with a wide spillway at each end of the embankment. Although valley dams require less excavation work than charco and hillside dams, they are vulnerable and could be washed away by unexpectedly large volumes of run-off water. Considering the unpredictable weather pattern created by global warming, many valley dams have been destroyed by extremely high rainfall.

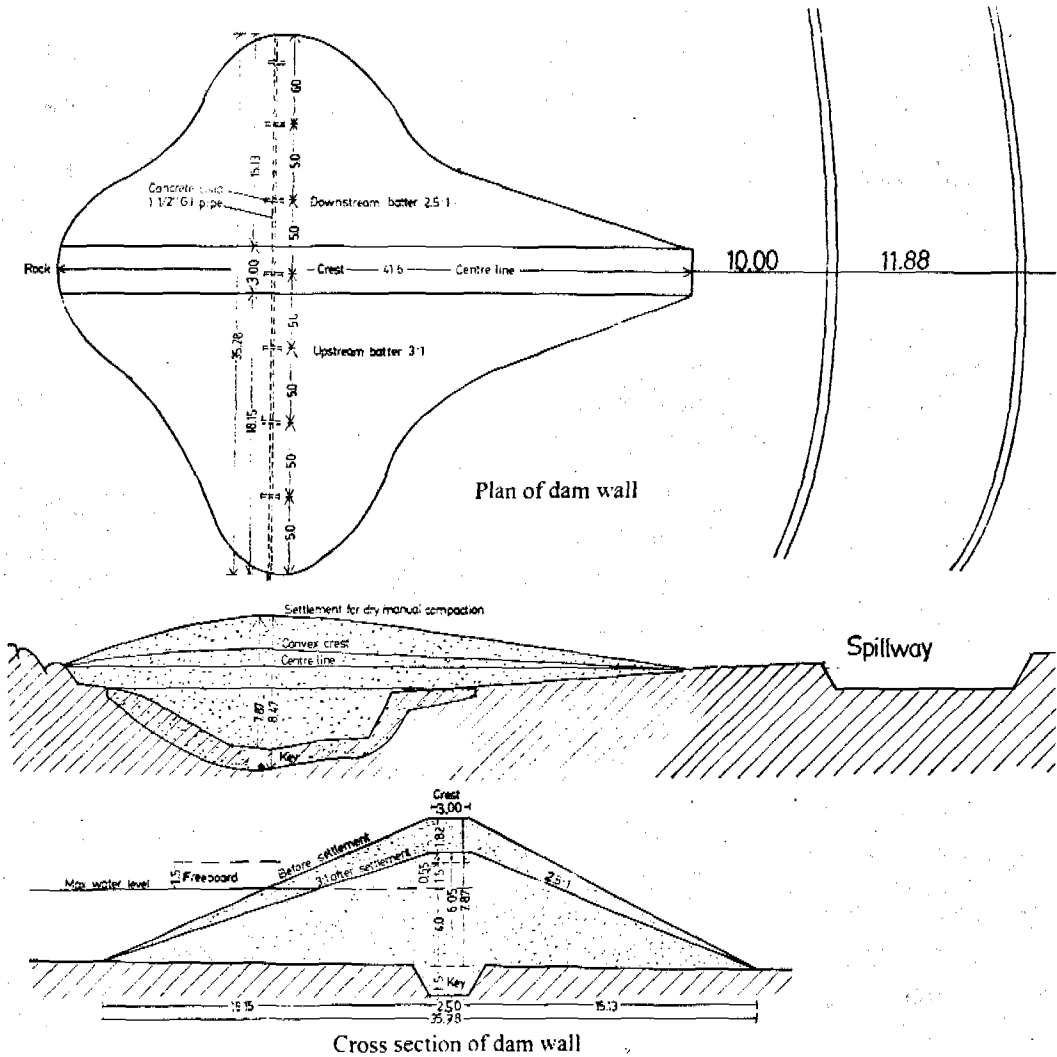

Plan and profiles of a valley dam. Source: *Water from ponds, pans and dams* by the author for RELMA/Sida in Kenya, 2005.



Construction of the designed dam by manual labour.

2.8 Tools and equipment for soil works



Plots having a volume of 1 cubic metre of soil are pegged out and distributed.

The "owners" of the plots excavate the soil and load it onto wheelbarrows. Women transport the soil to the dam wall, off-load it and compact it manually.

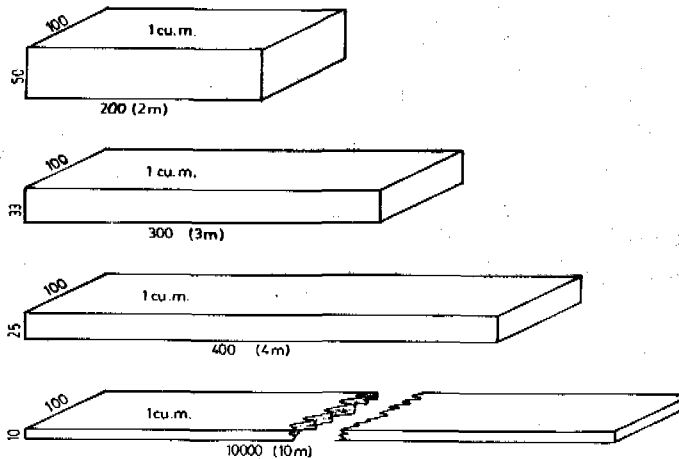

Various sizes of plots all with the same volume of 1 cubic metre of soil.

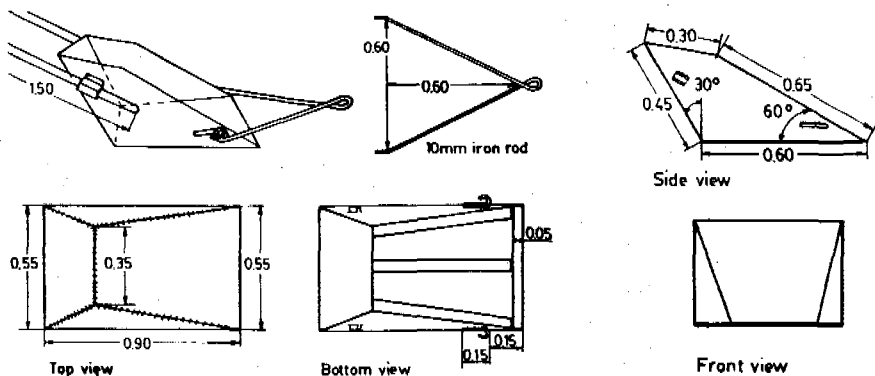

An ox-scoop made of 4 mm steel plate; with a plough and ox-scoop, two men and two oxen can excavate and transport more soil than 10 able-bodied men.

2.9 Analysis of soil samples

It is important to analyse samples of soil that shall be used for construction of dams in order to minimise seepage losses. Naturally, the most clayey soil found on a dam site should be used for those parts of a dam wall that should be as impermeable as possible. Sandy soils should be used on the downstream side of a dam wall where weight, and not impermeability, is required.

A soil test that gives the percentage of clay, silt, sand and gravel can be carried out

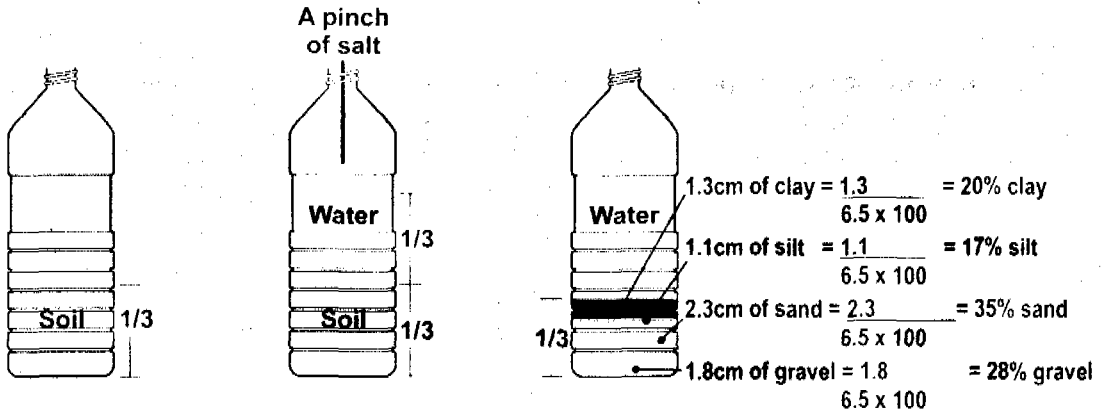

using a transparent bottle as follows:

Fill a transparent bottle 1/3 with a soil sample and 1/3 with water. Add a pinch of salt. Shake the bottle vigorously for 1 minute. Leave it for 1 hour, then shake again. After 4 hours, measure the thickness of each layer in the bottle. The upper layer is clay followed by silt, sand and gravel at the bottom. Find the percentage of each layer by measuring its thickness against the total thickness of the soil sample and multiply by 100.

Another simpler but less accurate method is to remove the caps and bottoms of some transparent plastic bottles. Fill the bottles halfway with soil and top up with water. Keep on adding water while watching the speed with which the water infiltrates the soil.

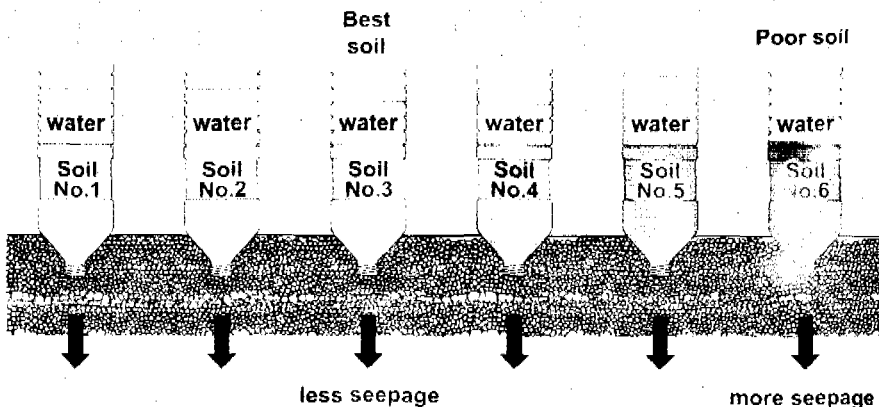

Soil with the least infiltration has the highest clay content and is therefore the most suitable soil to use for the impermeable parts of a dam wall and its reservoir.

Source: *Water from ponds, pans and dams* by the author, for RELMA/Sida in Kenya, 2005.

2.10 Construction costs of earth dams

The four types of earth dams listed below have different construction costs depending on the *construction method* and the *water-to-soil ratio*.

- a) **The construction method** relates to whether the excavation is done:
- 1) Manually with shovels and wheelbarrows costing about Ksh 100/cu.m. soil.
 - 2) With draught animals, scoops, ploughs and carts, costing about Ksh 60/cu.m.
 - 3) Hiring a farm tractor with a plough and scoop costing about Ksh 80/cu.m.
 - 4) Hiring a crawler (bulldozer) costing about Ksh 300/cu.m. soil.
- b) **The water-to-soil ratio** depends on the type of dam, because the volume of water:
- 1) A pond is equal to the volume of excavated soil, therefore the ratio is 1:1.
 - 2) A charco dam is equal to the volume of soil, therefore also 1:1.
 - 3) A hillside dam is 1.5 times more than the excavated soil, therefore 1.5:1.
 - 4) A valley dam is 3 times more than the excavated soil, therefore 3:1.

Although valley dams have the lowest construction cost per m³ soil, because they can store about 3 times more water than the excavated soil, they have a much higher rate of failure than other types of earth dams.

Type of dam	Construction method	Reservoir volume cu.m.	Water to soil ratio	Excavated soil cu.m.	Cost per cu.m.	Total cost Ksh.	Cost per cu.m. of water storage Ksh.
Excavated pond	Manual	100	1:1	100 x	100 =	10,000	100
Charco dams	Manual	500	1:1	500 x	100 =	50,000	100
	Tractor	500	1:1	500 x	80 =	40,000	80
	Oxen	500	1:1	500 x	60 =	30,000	60
Hillside dams	Manual	500	1.5:1	333 x	100 =	33,300	66
	Tractor	500	1.5:1	333 x	80 =	26,640	53
	Oxen	500	1.5:1	333 x	60 =	19,980	40
Valley dams	Crawler	5,000	3:1	1,670 x	300 =	501,000	100
	Manual	5,000	3:1	1,670 x	100 =	167,000	33
	Tractor	5,000	3:1	1,670 x	80 =	133,600	27
	Oxen	5,000	3:1	1,670 x	60 =	100,200	20

Source: *Water from ponds, pans and dams* by the author, for RELMA/Sida in Kenya, 2005.

2.11 References on earth dams

- Design and Construction of Small Earth Dams*. Nelson, K.D. Australia 1985.
Field Engineering for Agricultural Development. Hudson, Oxford, UK.
Small Earth Dam built by Animal Traction. Nissen-Petersen, E., Danida Kenya 1990.
Small earth dams. Brown, L.N. University of California, USA 1965.
Water from ponds, pans and dams. Nissen-Petersen, E. RELMA/Sida Kenya 2005.
Water from Small Dams. Nissen-Petersen, E. Danida Kenya 2006.

Chapter 3. Water tanks

3.1 Advantages of water tanks.

In regions with sandy soils, much water is usually lost from seepage in earth dams, and additional water is also lost by evaporation due to the large surface area of the water reservoirs. Furthermore, earth dams have other disadvantages such as siltation of reservoirs due to lack of proper soil conservation, erosion by livestock watered in the reservoirs, water-borne diseases and vector carried diseases.

Since it is difficult and expensive to reduce these disadvantages of earth dams, it may be more applicable to build water tanks. Although the capacity of water tanks is smaller than earth dams, they have several advantages, such as:

- 1) Seepage can be eliminated by lining water tanks with clay, anthill soil, burnt bricks, concrete blocks, ferro-cement or butyl rubber sheets.
- 2) Evaporation can be greatly reduced by roofing water tanks with live vegetation on wires, iron sheets, concrete covers or ferro-cement domes.
- 3) Siltation can be eliminated by excavating and regularly emptying silt traps.
- 4) Contamination by livestock and vectors can be avoided if the tanks are covered.

A number of well-functioning water tanks for harvesting rainwater run-off from roads are described in the following pages. A common feature for all the tanks is that none of them have a square or rectangular shape because these shapes always tend to crack.

Water tanks should always have a hemispherical or a cylindrical shape, because these shapes distribute equally the external and internal pressures on the wall, thereby eliminating the risk of cracks due to uneven tension.

3.2 Excavation of hemispherical tanks. Another common feature is that the tanks are built against the wall of solid soil exposed by the excavation works thereby ensuring a solid support of the entire tank wall.

Excavation of hemispherical tanks is made accurately by using a wire with the desired radius, tied to a peg in the centre column.

The centre column is removed as the last part of the excavation.



3.3 Hemispherical tank built of burnt bricks.

Lay the first brick on its side in the centre of the tank. Thereafter lay the following bricks on their sides as a spiral winding their way up towards the ground level.

For every metre or so, moisten the bricks and compact mortar into the spaces between the bricks, with a mixture of 1 part cement to 4 parts of coarse sand (1:4).

When the laying of bricks has reached ground level, a centre pipe is erected and a radius wire is tied onto it for building the circular foundation wall, which prevents children and animals falling into the tank.

A silt trap built in front of the inlet. Two gaps are made opposite each other to cater for the inlet of rainwater and outlet for water overflowing the tank.

Barbed wire is then wrapped tightly in a spiral around the outside of the tank wall above ground level, with a spacing of 10 cm.

Chicken mesh is thereafter nailed onto the inner wall of the tank for additional reinforcement.

The internal and external walls are then plastered with 1:4 mortar and made water-proof with NIL (cement slurry) the same day.



A centre post made of a PVC pipe filled with concrete is erected in the centre onto which barbed wire is tied to form a roof. A lockable manhole is fitted on the roof. The tank is coated with a weather-proof mixture of 1 part of cement to 10 parts of lime mixed with water.

Water can be drawn from the tank by a bucket in a rope or another simple lift.

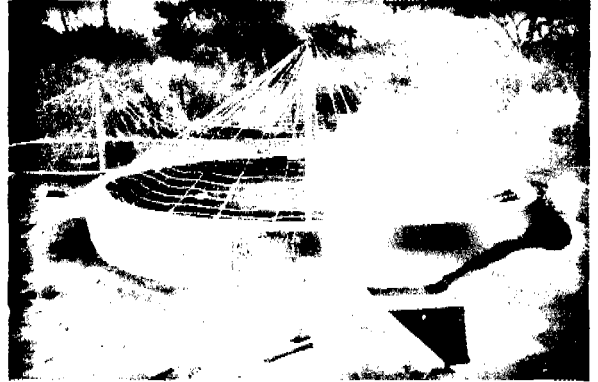

Formula for calculating the volume and surface area of a hemispherical tank

The volume of a hemispherical water tank can be calculated using the following formula: $\frac{2}{3} \times \pi \times r^3$, or simplified to: $\frac{2}{3} \times \frac{22}{7} \times \text{radius} \times \text{radius} \times \text{radius} = \text{Volume}$.

The volume of this tank: $\frac{2}{3} \times (\frac{22}{7} \times \text{radius } 2.17 \text{ m} \times \text{radius } 2.17 \text{ m} \times \text{radius } 2.17 \text{ m}) = \frac{2}{3} \times (\frac{22}{7} \times 10.218) = \frac{2}{3} \times 32.11 = \mathbf{21.41 \text{ cu.m volume}}$

The surface area of this tank can be calculated using the formula of: $2 \times \pi \times r^2$, that can be simplified to: $2 \times \frac{22}{7} \times \text{radius } 2.17 \times \text{radius } 2.17 = 29.60 \text{ sq.m.}$

+ superstructure: $d \times \pi \times h$: diameter 4.34 $\times \frac{22}{7} \times \text{height } 0.8 = 10.91 \text{ sq.m}$

Total inner surface area = 40.51 sq.m.

Bill of quantities and cost of a 21 cu.m. hemispherical tank built of burnt bricks

Description	Unit	Quantities	Unit cost Ksh	Total cost Ksh
Labour cost				
Artisan	Artisans	1 x 10 days	400/day	4,000
Labourers	Labourers	3 x 15 days	200/day	9,000
Cost of labour				13,000
Materials				
Bags of cement	50 kg bags	25	600	15,000
River sand	Tonnes	6	200	1,200
Crushed stones	Tonnes	1	600	600
Burnt bricks 4"x 6"x 10"	Units	1,170	5	5,850
Water	Oil-drums	5	100	500
Y 12 twisted iron bars	Lengths	½	600	300
Barbed wire	20 kg rolls, g 12.5	1	3,000	3,000
Chicken mesh	3' x 90' x 1", rolls	2	3,000	6,000
Nails, 2"	Kg	5	100	500
Lime	25kg	3	400	1,200
uPVC, 4" sewage pipe	Lengths	1	400	400
Cost of materials				34,550
Transport of materials				
Hardware lorries	3 tonnes	1 loads	3,000	3,000
Tractor trailer loads	3 tonnes	7 loads	900	6,300
Cost of transport				9,300
Total cost of a 21 cu.m. tank				56,850

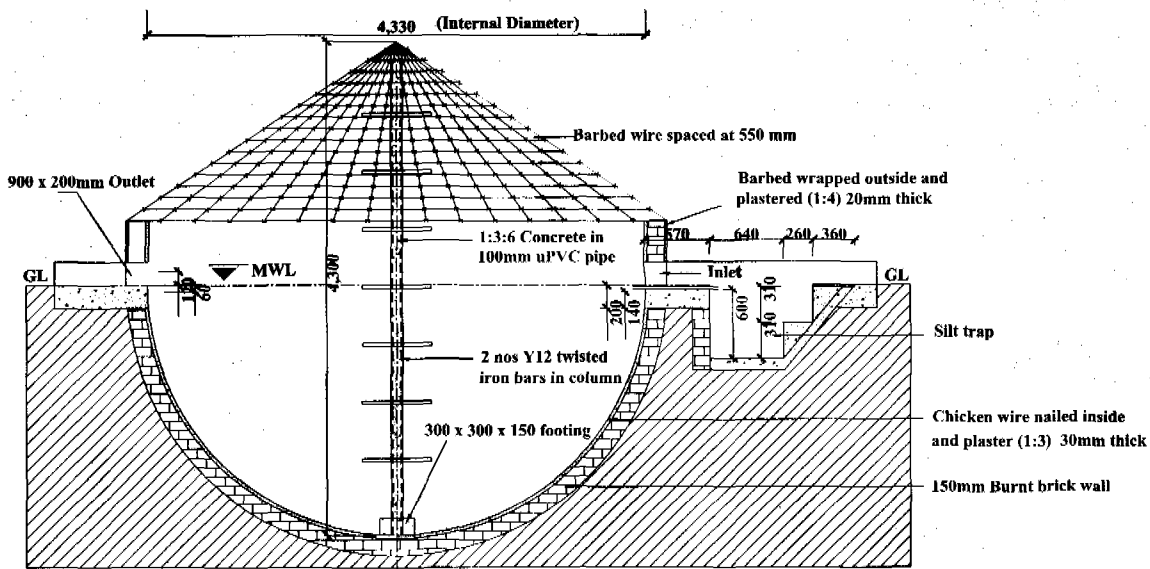

SECTION A-A (mm)

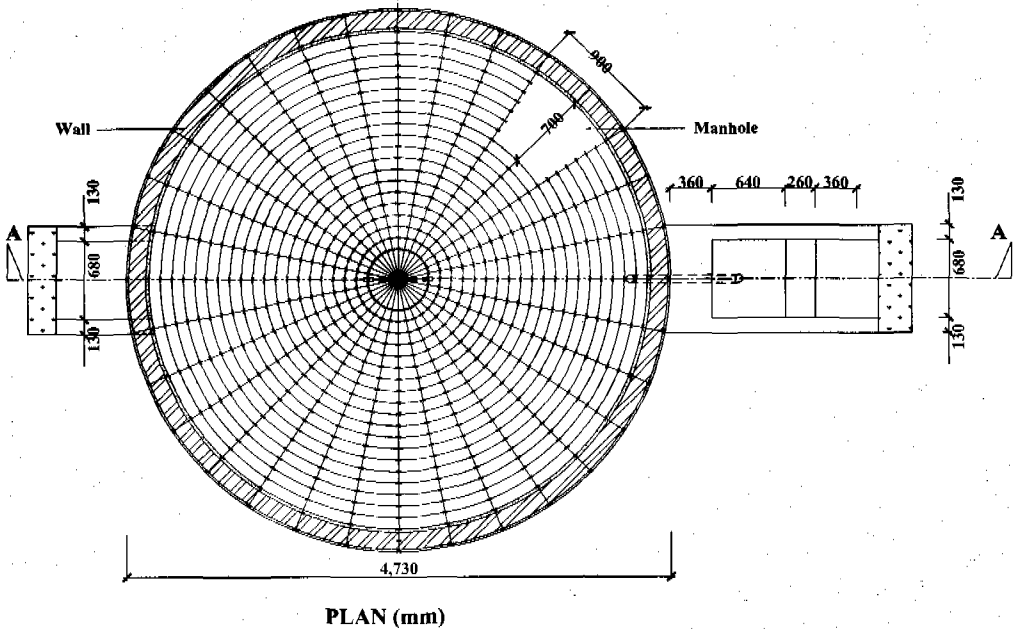

Cross section and plan of a 21 cubic metre tank built of burnt bricks.

3.4 Hemispherical tanks built of anthill soil, lime and cement

As seen above, the cost of building a water tank of burnt bricks with a storage volume of 21.4 cu.m. is Ksh 56,850, equivalent to Ksh 2,656 per cubic metre storage volume.

The construction cost can be reduced by using powdered anthill soil as a part substitute for cement and burnt bricks. The best of the two tanks described below has a storage volume of 48 cu.m. and was constructed for Ksh 34,360, equivalent to Ksh 716 per cubic metre storage volume. However, this saving of Ksh 1,940 per cu.m. as compared against the above brick tank, comes with a higher cost of maintenance and repair.

Nevertheless, it is an affordable tank to construct for most rural people. The cost of maintenance and repair can be recovered using the water for cash generating activities, such as growing and selling vegetables and tree seedlings, making and selling burnt bricks, selling water, watering livestock, etc.

A dozen tanks were built of various mixtures of powdered anthill soil, lime, murrum and cement 20 years ago by the author in Mutomo in Kitui District. A recent follow-up on these tanks showed that some of the tanks are still performing well after two decades even despite lack of maintenance. Unfortunately, the records for the mixture ratios are lost and forgotten.

This tank was built of the cheap materials mentioned above. 20 years of neglect have not weakened the tank.

A representative of RELMA/Sida is admiring the inflow channel which has not been eroded by inflowing water.



This picture shows another one of those old tanks built of cheap materials for harvesting run-off water from a road.

Only the surface of the plaster along the water level has eroded slightly.

There is no sign of the cone of sisal poles that prevented people and animals from falling into the tank.



Two water tanks were built of anthill soil, lime, sand and cement during a training course at Makaani Primary School at Kibwezi in 1998.

- 1) The tanks were excavated using a radius wire that was 290 cm long and their volume was calculated as follows:
- 2) The radius of each tank: 290 cm minus 6 cm of plaster = 284 cm radius
- 3) The volume of each water tank was calculated using the formula of:
 $\frac{2}{3} \times \pi \times r^3$ simplified to: $\frac{2}{3} \times (22/7 \times \text{radius} \times \text{radius} \times \text{radius}) = \text{Volume}$.
- 4) The volume of this tank: $\frac{2}{3} \times (22/7 \times \text{radius } 2.84 \text{ m} \times \text{radius } 2.84 \text{ m} \times \text{radius } 2.84 \text{ m}) = \frac{2}{3} \times (22/7 \times 22.91) = \frac{2}{3} \times 72.00 = 48.00 \text{ cu.m volume}$
- 5) The surface area of this tank can be calculated using the formula of: $2 \times \pi \times r^2$ that can be simplified to: $2 \times 22/7 \times \text{radius } 2.84 \times \text{radius } 2.84 = 50.70 \text{ sq.m}$.
plus superstructure: $d \times \pi \times h = 5.68 \times 22/7 \times \text{height } 0.8 = 14.28 \text{ sq.m}$
Total inner surface area 64.98 sq.m.

Two types of plaster

Anthills were broken into particles that could pass through a sieve made of coffee mesh.



A woman sieving anthill soil.

a) The 6 cm plaster for one tank was made of:
4 parts anthill soil
1 part cement
2 parts lime
6 parts river sand

b) The 6 cm plaster for the other tank was made of:
20 parts anthill soil
2 parts cement
1 part lime
18 parts river sand

The 6 cm thick plaster was reinforced with chicken mesh nailed to the first coat of 3 cm plaster. After 14 days of curing the plaster was coated with bitumen paint.

A visit to the tanks three years later showed that the plaster mixture (a) above was the most superior, although the inflow of water had eroded part of the plaster due to a complete lack of maintenance by the school, its pupils and parents.

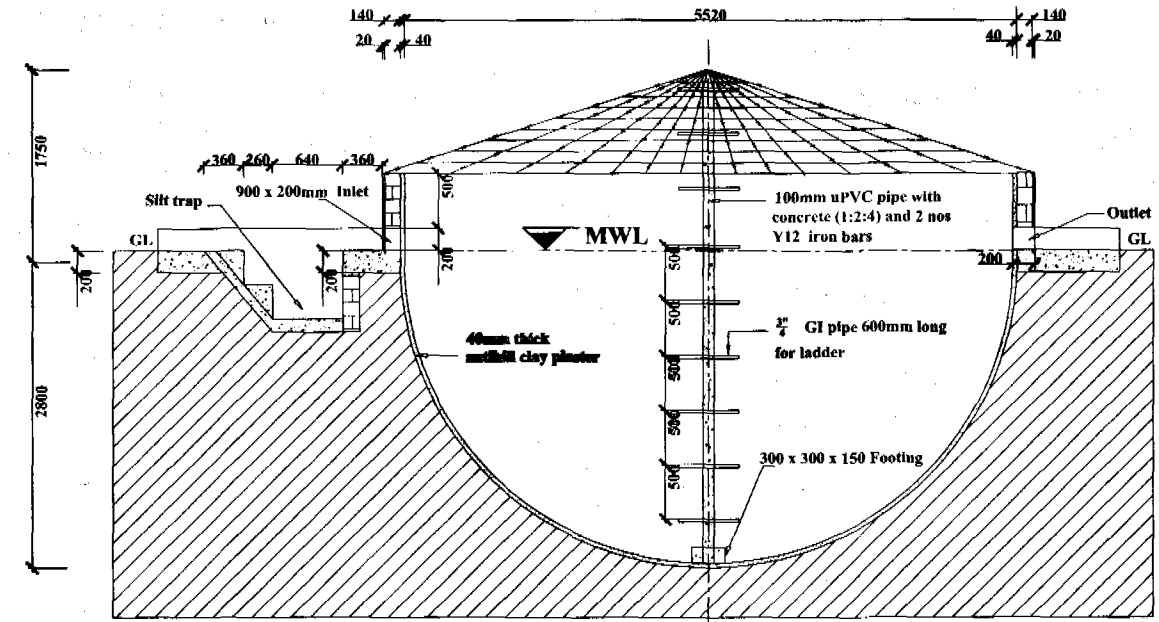

SECTION A-A (mm)

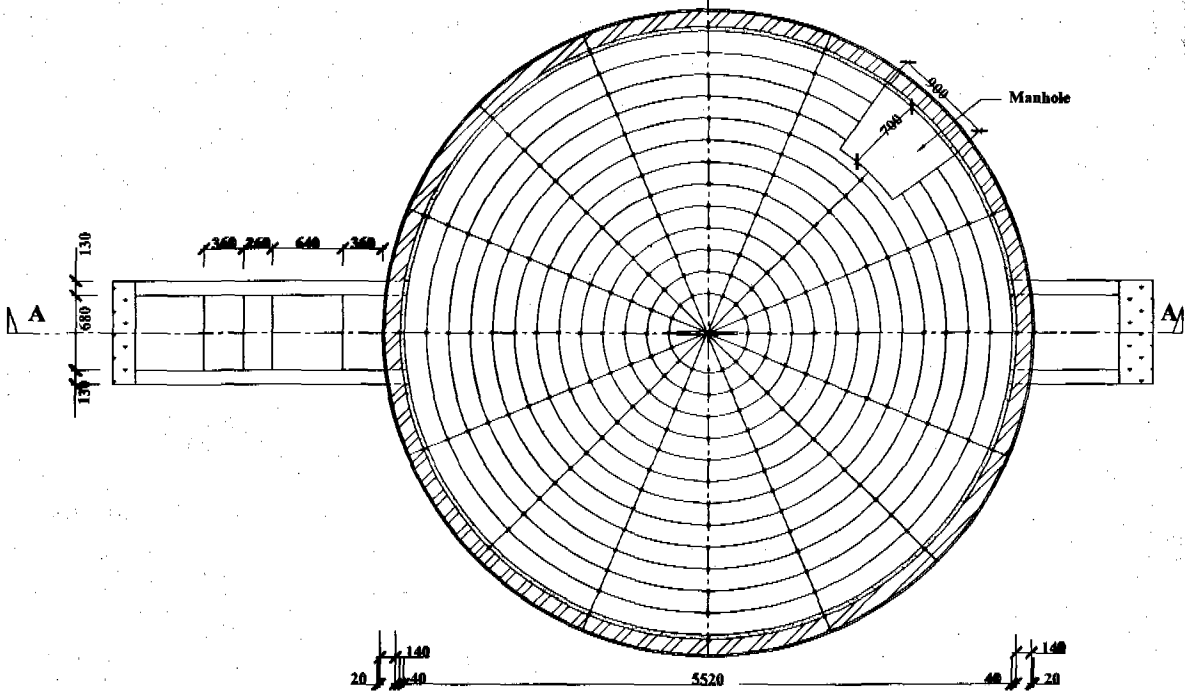

PLAN (mm)

Cross section and plan of 48 cu.m. water tank built of anthill soil, lime, sand and cement

Bill of quantities and cost of the best 48 cu.m. tank built of anthill soil, lime, etc.

Description	Unit	Quantity	Unit cost Ksh	Total cost Ksh
Anthill soil	Tonnes	7	300	2,100
Cement	50 kg bags	5	600	3,000
Lime	25 kg bags	3	300	900
Crushed stones	Tonnes	1	600	600
River sand	Tonnes	7	200	1,400
Burnt bricks	Numbers	300	5	1,500
Chicken mesh	3 ft. x 90 ft. x 1"	3 rolls	3,000	9,000
Barbed wire	20 kg rolls, g 12.5	1 roll	3,000	3,000
PVC pipe	3 metres of 4"	1 length	400	400
Iron bars	3 metres of Y12	1/2 length	600	300
Nails	5 kg of 2"		100	500
Water	7 oil drums		100	700
Artisan	1 artisan	10 days	400	4,000
Labourers	3 labourers	15 days	200	9,000
Total				36,400



The first ground tanks for harvesting rainwater from roads and compounds were roofed with corrugated iron sheets tied onto galvanized iron pipes in 1983. Since goats and cattle could smell the water, they walked on the roofs and damaged them.

The iron sheet roofs were therefore replaced by sisal poles arranged in a pyre and held together with an old tyre at the top. Passion fruit and lupher plants were grown on barbed wire wrapped around the sisal poles.

3.5 Hemispherical tanks built of ferro-cement

Some 100 hemispherical water tanks with a storage volume of 60 cu.m. and 90 cu.m. were built of ferro-cement for roof and ground catchments by the Danida funded *Mutomo Soil & Water Conservation Project* in Kitui in the 1980s.

The ferro-cement tanks are still in good shape but the roofs, made of corrugated iron sheets nailed onto timber, collapsed after some years. The collapsed roofs could easily and cost-effectively be replaced with domes made of ferro-cement, but no-one has taken on this responsibility.

A USAID Peace Corps Volunteer replicated and enlarged the volume these hemispherical tanks in many places in Kenya. Many of these larger than normal tanks have cracked because the usual the reinforcement of barbed wire and chicken mesh is insufficient when the storage volume exceeds 100 cu.m. Some of these large tanks have been rehabilitated by building a new tank inside the damaged ones.

The 60 cu.m tanks were constructed as follows:

A peg was hammered into the centre of the tank, and a wire having a length of 312 cm was tied to the peg.

This radius wire was used to guide the builders in getting the correct hemispherical shape. The centre column was removed after the hemispherical shape was completed.

The excavated wall of soil was plastered with a 3 cm thick coat of mortar, with a mortar mixture of 1:3. It had to be completed in one day.

The next day, the barbed wire and chicken mesh were nailed to the coat of mortar applied the day before. The following day, a second 3 cm coat of mortar was applied onto the reinforcement and made water-proof with NIL. Then the mortar was cured with water and kept under shade for 3 weeks.



During the curing, a reinforced concrete beam was built onto the rim of the tank. Sisal poles were set in a groove of the beam to form a cone-shaped roof onto which barbed wire was wrapped around. A silt trap was made at the inflow to the tank and an overflow at the opposite side of the tank.

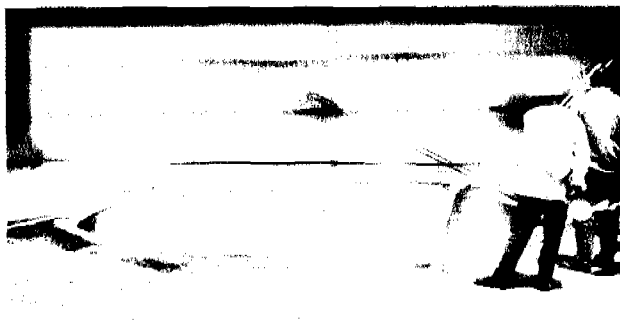

Bill of quantities for a 60 cu.m. hemispherical tank built of ferro-cement

Description	Unit	Quantity	Unit cost Ksh	Total cost Ksh
Labour cost				
Artisan	Artisans	3 x 14 days	400/day	16,800
Labourers	Labourers	4 x 20 days	200/day	<u>16,000</u>
Cost of labour				32,800
Materials				
Bags of cement	50 kg bags	50	600	30,000
River sand	Tonnes	14	200	2,800
Crushed stones	Tonnes	1	600	600
Burnt bricks, 4"x 6"x10"	Units	800	5	4,000
Water	Oil-drums	45	100	4,500
Y 12 twisted iron bars	Lengths	1	600	600
Barbed wire	20 kg rolls, g 12.5	5	3,000	15,000
Chicken mesh	3' x 90' x 1", rolls	3	3,000	9,000
Galvanized ceiling nails	Kg	5	130	650
Lime	25 kg	2	400	800
uPVC, 4" sewage pipe	Lengths	1	400	400
G.I pipe	1½"	1	2,500	2,500
G.I fitting	1½" elbow, nipple	2	500	1,000
Mosquito mesh	Plastic	1	100	100
Lockable door	Steel, 3' x 7' (feet)	1	5,000	5,000
Galvanized coffee mesh	Cu.m.	1	200	200
Cost of materials		1	200	<u>200</u>
				77,350
Transport of materials				
Hardware lorries	7 tonnes	1 loads	5,000	5,000
Tractor trailer loads	3 tonnes	20 loads	900	<u>18,000</u>
Cost of transport				23,000
Total cost a 60 cu.m tank				133,150

The construction cost per cu.m. storage volume is: Ksh 133,150/ 60 cu.m. =
Ksh 2,219/cu.m.

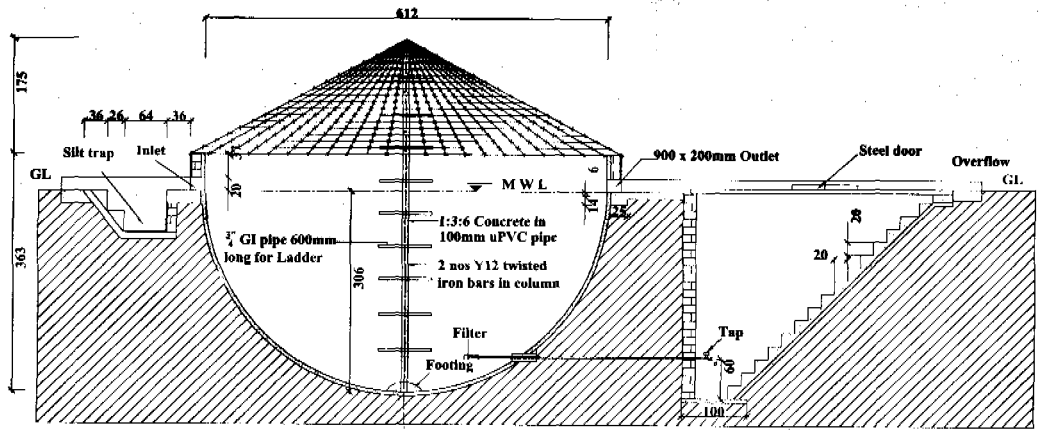

SECTION A - A (cm)

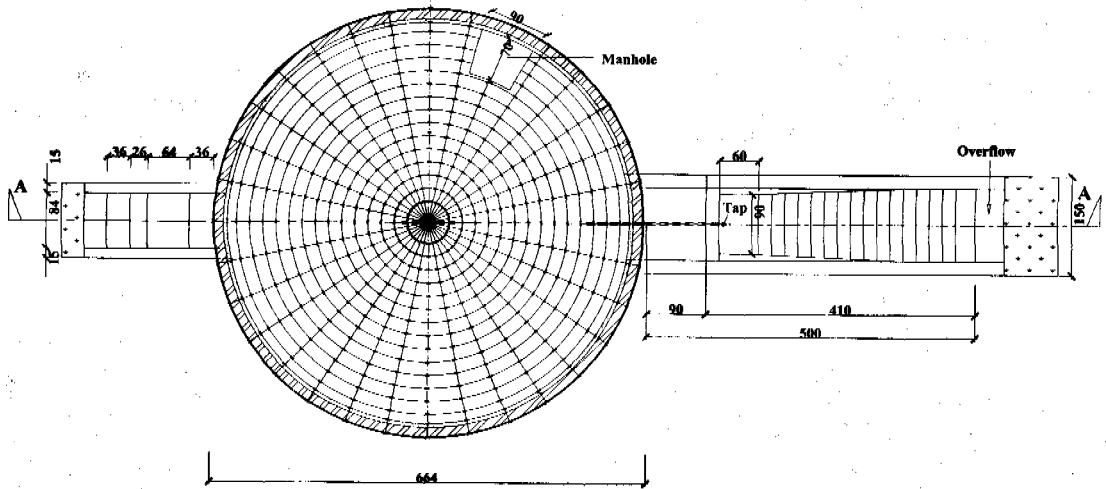

PLAN

Standard design of a 60 cu.m. hemispherical water tank built of ferro-cement.

In order to avoid hand pumps which require maintenance and spare parts occasionally, this design features a staircase leading down to a watertap from which water can be drawn by gravity from the tank.

An additional advantage is that the staircase is also functions as a water reservoir. When surplus water is overflowing, it spills over onto the staircase. Water is drawn from the staircase by opening the steel door covering it and lifting a bucket of water out of the staircase.

3.6 Cylindrical underground water tanks

Cylindrical tanks have been used for many years to harvest and store rainwater running off threshing floors from the sparse rains in the semi-desert areas of Botswana.

Water is drawn with a bucket from the manhole on the cover of the tank as illustrated in this photo.



A sketch showing the catchment area, which could have been a road as well, and the underground cylindrical tank built of burnt bricks.

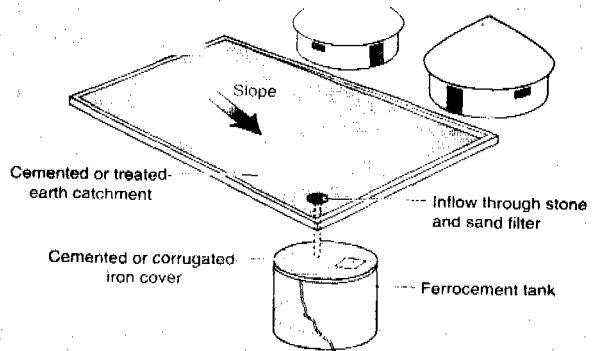

This type of cylindrical ground tank is used in the hot and arid Northern Namibia to store water for construction of schools.

These tanks are also very suitable for collecting rainwater run-off from roads.



These two cylindrical ground tanks were built of soil compressed blocks for fish farming at Machakos in Kenya in 1980s. The tanks could also have been used for harvesting rainwater from roads.

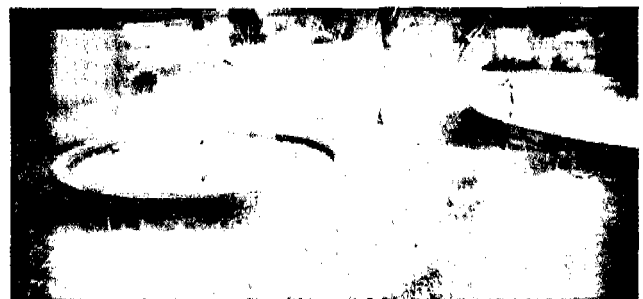



This tank was initially built for storage of water for construction during a training course at Kibwezi in Kenya in 1997. Upon completion of the training, the tank was equipped with a silt trap and used for harvesting water from a road.

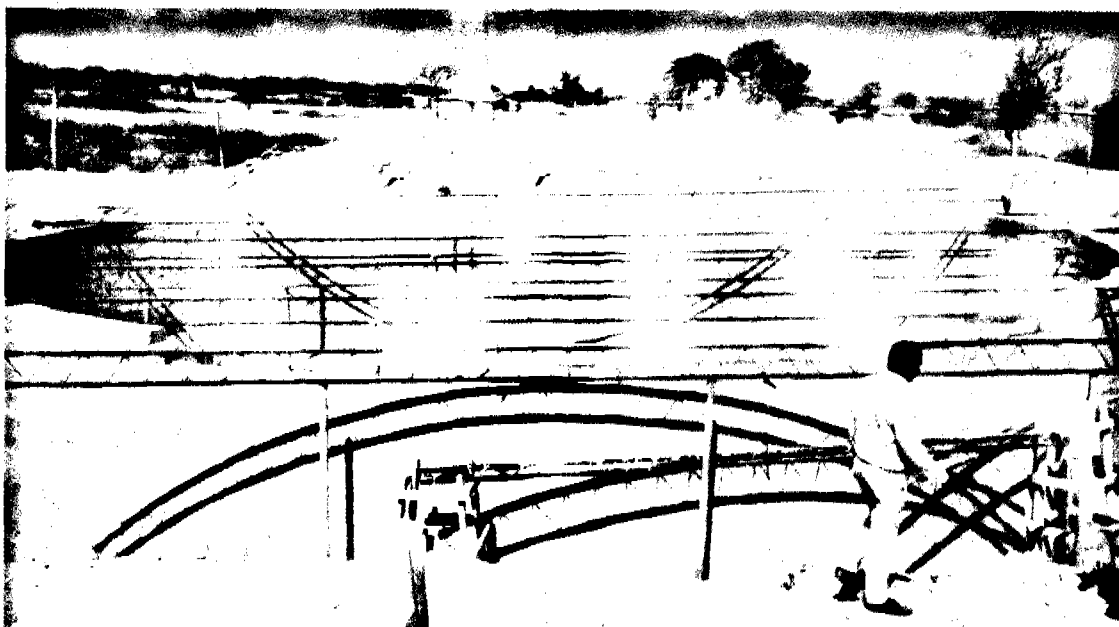

This gigantic cylindrical ground tank was constructed for harvesting rainwater from a large concrete apron near Dodoma in Tanzania in 1992. The tank could also have been used as road catchment of rainwater.

3.7 Berkads

Berkads are tanks that are excavated and lined with concrete blocks or ferro-cement in the semi-desert regions of Somaliland. Rainwater running off roads and hillsides is diverted into the berkads by soil bunds sloping upwards on hillsides until they reach a road.

Most berkads have rectangular shapes with vertical walls that crack due to uneven external pressure of the soil when the berkads dry up.

Water is drawn from berkads by either using the steps or the hand-dug well seen in the upper photo.

This handbook promotes the much stronger oval-shaped berkads that has a shape as the silt trap in this photo.

A newly made soil bund winds its way downwards though the bush from an unpaved road on a hillside.

Walking down hill in the bund, a newly built berkad is reached at the end of the bund.

The bund guides the run-off water into the silt trap before it enters the berkad.

The excavated soil has been back-filled against the berkad. This could facilitate siphoning of water downhill for watering livestock or small-scale irrigation.

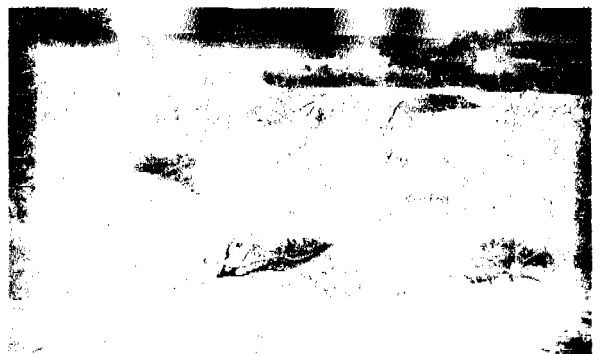
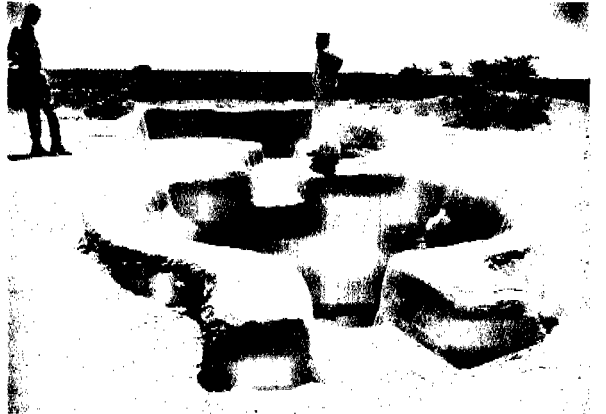

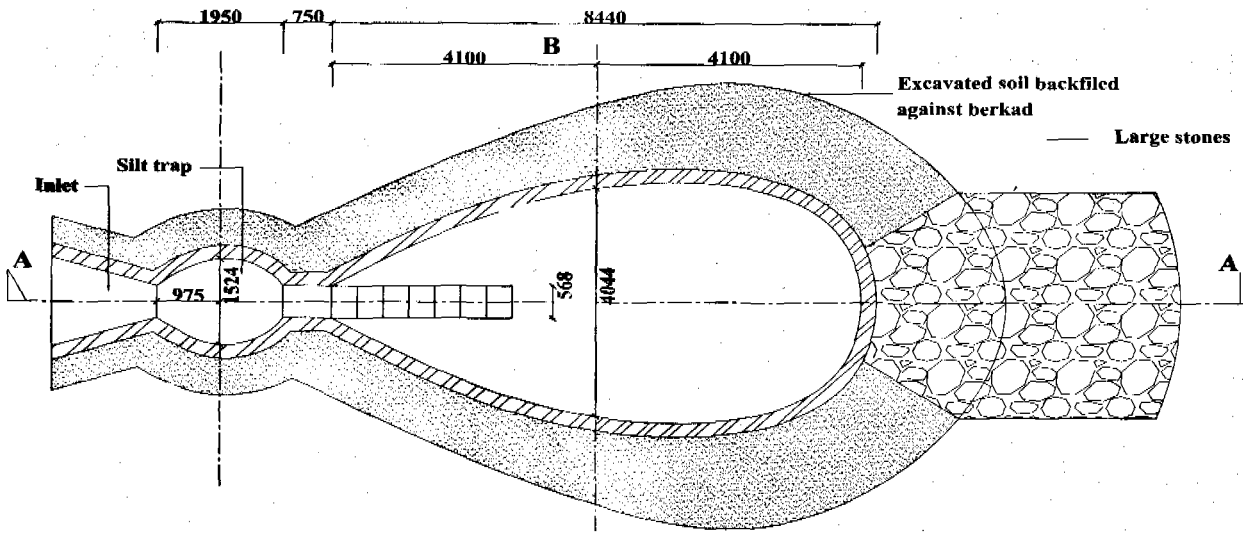
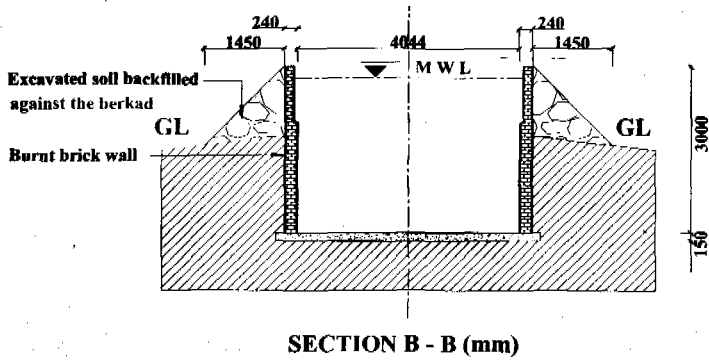
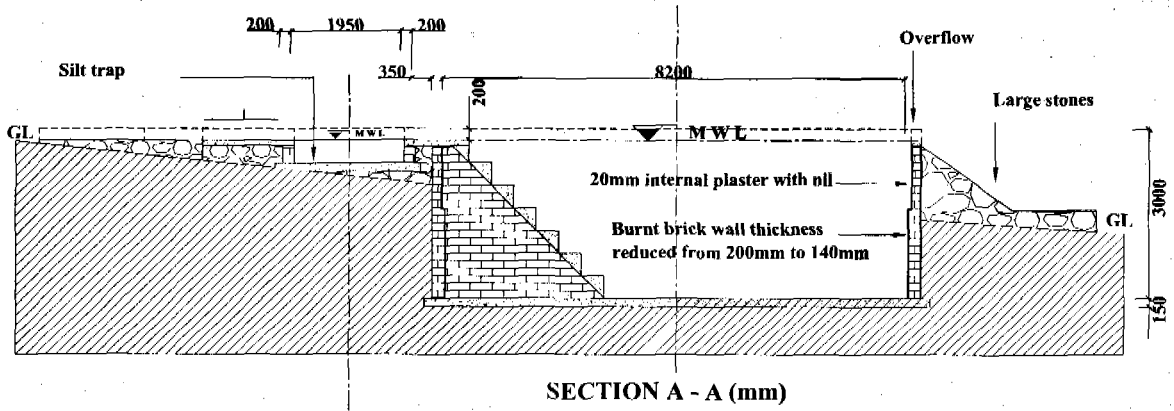

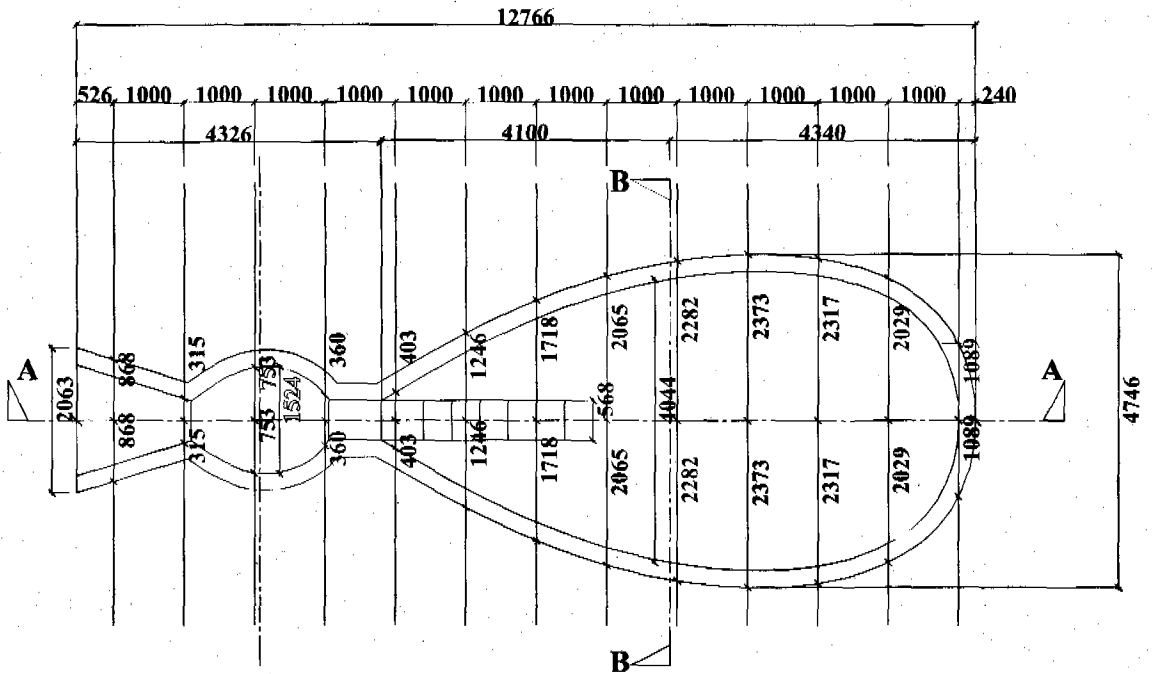

PLAN OF EXCAVATION

Marking a berkad on the ground can be made as follows:

- 1) Mark the highest place of the site for the inlet with a wooden peg.
- 2) Mark the lowest place of the site for the overflow with a peg situated 13 m from the inlet.
- 3) Draw a 13 m long nylon string between the two pegs. The string represents the centre line, called A-A, on the plan seen above.
- 4) Then place 14 pegs along the centre line with the intervals shown in centimetres below. The length of the berkad is 12766 mm = 1276.6 cm = 12.766 m = 12.77 m.
- 5) Starting from peg No. 1 at the inlet and measuring towards peg No. 14 (listed in the upper row) the measurements between the pegs are listed as cm in the middle row.
- 6) The figures in the lowest row are the distances from the centre line to the edge of the excavation. Use a long mason's square to mark these measurements at an angle of 90 degrees to the centre line.

1	2	3	4	5	6	7	8	9	10	11	12	13	14	Total
53	100	100	100	100	100	100	100	100	100	100	100	100	24	1277
103	87	32	75	36	40	125	172	207	228	237	232	203	109	

Excavation of a berkad is done as follows:

- 1) First excavate the walls of the water reservoir by cutting along the line marked on the ground.
- 2) Thereafter excavate the wall vertically downwards using either a spirit level or a plumber's rod, while also removing the soil within the wall. The excavated soil is dumped outside and around the lower end of the berkad from where it is back-filled after the wall is built.
- 3) The depth of the excavation should be 313 cm at the silt trap and the floor should be horizontal when measured from there.
- 4) When the reservoir has reached its final depth, the silt trap is excavated as shown in the design on the previous page.

Concreting the floor of a berkad is done before building the wall.

- 1) First 7 cm thick layer of concrete 1:3:4 is compacted onto the excavated floor. Then a layer of weld mesh is laid onto the concrete. Thereafter a 7 cm thick layer of concrete 1:3:4 is compacted onto the weld mesh and smoothed. The work of concreting the floor must be completed in 1 day.
- 2) The concrete floor must be kept moist and covered with polythene, empty cement bags or grass for 3 weeks of curing.

The wall of a berkad can be built of several types of materials depending on the soil structure of the excavation.

- 1) The options are: burnt bricks, concrete blocks, rubble stones or ferro-cement. A disadvantage of ferro-cement is that the wall must be kept moist and under shade for 3 weeks, otherwise the wall will be porous and might leak.
- 2) The technique of building a wall of ferro-cement is described on page 23.

The inlet and silt trap can be made of the same material as the wall of a water reservoir.

A soil or stone bund starts from the inlet and winds its way upwards with a gradient of about 3 degrees until it reaches a road or a rock outcrop capable of supplying sufficient run-off to fill the berkad with water.

Bill of quantities and cost of a berkad

Description	Unit	Quantity	Unit cost Ksh	Total cost Ksh
Labour cost				
Artisan	Artisans	1 x 14 days	400/day	5,600
Labourers	Labourers	3 x 14 days	200/day	<u>8,400</u>
Cost of labour				14,000
Materials				
Bags of cement	50 kg bags	30	600	18,000
River sand	Tonnes	9	200	1,800
Crushed stones	Tonnes	3	600	1,800
Hardcore 2" to 6"	Tonnes	7	200	1,400
Burnt bricks 4" x 6" x 10"	Units	1,500	5	7,500
Water	Oil-drums	20	100	2,000
Y 12 twisted iron bars	Lengths	2	600	1,200
Barbed wire	20 kg rolls, g 12.5	1	3,000	3,000
Chicken mesh	3' x 90' x 1", rolls	2	3,000	6,000
Galvanized ceiling nails	Kg	4	130	<u>520</u>
Cost of materials				43,220
Transport of materials				
Hardware lorries	3 tonnes	1 loads	5,000	5,000
Tractor trailer loads	3 tonnes	13 loads	900	<u>11,700</u>
Cost of transport				16,700
Total Cost of a Berkad				73,920

3.8 Rectangular water tanks

The only type of water tanks with square and rectangular shapes that can be recommended is seen in these two photos.

The main features of the tanks are:

- a) the sides of the excavation must have a low gradient and be covered by butyl rubber or PVC sheets;
- b) the surface of the excavation must be smooth without any sharp objects that can puncture the sheets;
- c) the sheets covering the excavation must be glued together by experts, to ensure water-tightness.



The disadvantages are:

- a) the sheets are expensive,
- b) the sheets can be punctured by livestock walking into the reservoirs,
- c) high evaporation losses, unless the tanks are covered with galvanized mesh attached to the center pole and onto which creepers can grow as shown in the upper photo.



3.9 References on water tanks

- Ferrocement Water Tanks and their construction.* Watt, S. IT Publications. UK.
- How to build cylindrical water tanks with domes.* Nissen-Petersen, E. 1990.
- How to build an underground tank with dome.* Nissen-Petersen, E. 1900.
- How to repair various types of water tanks.* Nissen-Petersen, E. 1990.
- How to build and install gutters with splash-guard.* Nissen-Petersen, E. 1990.
- How to build smaller water tanks and jars.* Nissen-Petersen, K. 1990.
- Make your own plastic lined underground tank.* Cherogony, KRA/RELMA 1999.
- Rain Catchment and Rural Water Supply.* Nissen-Petersen, E. H&S, UK, 1982
- Rainwater Catchment Systems.* John Gould and Nissen-Petersen, E. ITDG, 1999.
- Water from Roofs.* Nissen-Petersen, E. Danida Kenya, 2006.
- Water tanks with guttering and handpump* by Nissen-Petersen, E. Danida, 1990.

Chapter 4. Subsurface dams

Most rainwater running off roads passes through gullies and riverbeds on its way to the sea. Some of that water can be trapped in one, or several, of the types of subsurface dams that are described briefly in this chapter and in detail in another handbook of this series: *Water from Dry Riverbeds*.

4.1 Water in sand reservoirs

The main feature of subsurface dams is that their water reservoir is full of sand, where water is stored in the voids between the sand particles. 350 litres of water (35%) can be extracted from 1 cu.m. (1,000 litres) of coarse sand, due to its large voids. Fine-textured sand provides less than 190 litres (19%) of water from 1 cu.m. of sand, while only 50 litres (5%) of water may be extracted from silt due to its tiny voids. Subsurface reservoirs should therefore always contain as much coarse sand as possible. Storing of water in sand reservoirs has the following advantages:

- 1) Evaporation loss is minimal: Evaporation decreases proportionally with the water's distance to the sand surface, and it is reduced to zero at a depth of 60 cm below the surface of the sand.
- 2) The water is not contaminated by large numbers of animals, because the water is 'hidden' below the surface of the sand. Some contamination does occur by passing animals etc, but it is limited to the area close to the sand surface, and no contamination occurs at the depth where the water is extracted.
- 3) Mosquitoes and other disease-spreading insects, as well as frogs and snakes, cannot live in water stored in sand reservoirs.

Many gullies and riverbeds contain only fine-textured sand particles or no sand at all. In such cases, coarse sand can be trapped from floodwater by means of constructing a sand dam as explained in the next pages.

4.2 Floodwater passing roads

Floodwater can pass roads in two ways; either under bridges, or over the roads. The latter are called *drifts*. *Irish Bridges* are concrete drifts that may function as weirs by blocking the underground flow of water in the sand, thereby creating a water reservoir upstream of the bridge, as seen in the photo.



If Irish Bridges do not create water reservoirs, the upstream side of the bridges could be plastered with mortar or clayey soil, if the authorities allow. This photo shows water being piped from such a reservoir into a tank from where it is pumped up to a community.



4.2 Hand-dug wells

Hand-dug wells are the easiest and cheapest structures for the extraction of water from riverbeds containing sand. Wells can either be placed directly in a riverbed with a well-head protected against flood damage, or in a riverbank. The latter may require a perforated pipe to drain water from the riverbed into the well.

It is always important to sink a hand-dug well in, or at, the deepest part of a riverbed, because that gives access to the most water. Such deep places can be identified by either:

- 1) Trees, such as wild figs and other trees that can only grow where water is available all year round.
- 2) Water holes excavated by people or animals that yield water for some time or throughout dry seasons.
- 3) Dowsing by gifted persons walking along riverbeds in dry seasons.
- 4) Probing by hammering long and retrievable iron rods into the sand of riverbeds. This technique can produce hydraulic profiles that show the correct places to sink wells and boreholes, and to construct weirs and subsurface dams as shown below.

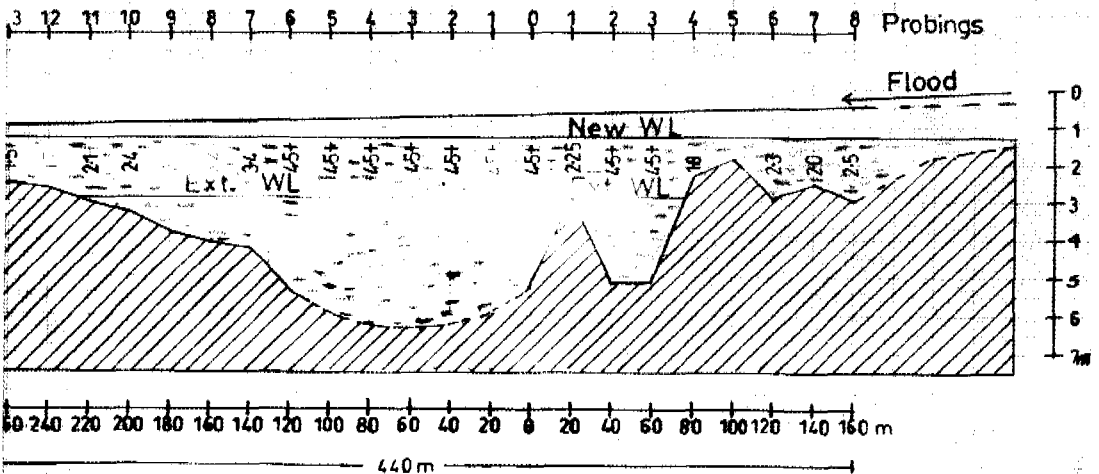

This longitudinal profile of a riverbed was drawn from measurements taken from probing with an iron rod at 20 metres intervals. The most suitable place for sinking a well is between probing number 2 and 4 on the left side of the profile because here the riverbed is deepest and will therefore provide most water.



Hand-dug wells can be built in two ways depending on their depths. Shallow wells can be excavated to their final depth and then built from the bottom and upwards with burned bricks as shown in this photo.

If hand-dug wells have to be sunk in deep sand, the "sinking" method should be used, because it is safe and economical.

The well-shaft is made of curved concrete blocks that are reinforced together, atop a concrete foundation ring which is made in a circular groove cut into the sand of the well site. The concrete blocks are then mortared and tied with GI wires onto the foundation ring with steps built in the wall for easy entry and exit. When sand is scooped out of the shaft, it sinks into the sand. More blocks are then added and scooping repeated, and so on until the shaft has sunk to its final depth.



Concrete culverts can also be used for sinking shafts but they are difficult to handle.

Water can be drawn from hand-dug wells using a windlass, which requires only a new rope once in a while as seen in this photo from Namibia. Note the cattle troughs made of tree trunks.



Wells can also be fitted with hand or motor pumps but that requires much more cash input, maintenance and repairs.

4.3 Subsurface dams, weirs and sand dams

When a hand-dug well in a riverbed cannot supply the required volume of water, the yield of water can be increased by raising the water table in the riverbed by means of building a subsurface dam, a weir or a sand dam. These types of dams are built downstream of the well and onto a natural dyke that is located somewhere downstream of the well.

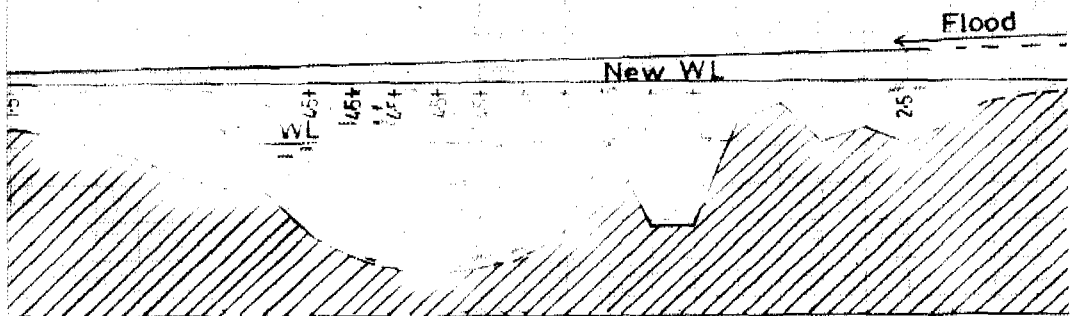

The most potential natural dyke of the four dykes seen in this profile, is situated at the far left side of the profile. A subsurface dam, which was built of soil on that dyke, raised the water level 1.5 metres from the existing water level (Ext. WL) to the new water level (New WL) along a 500 metres long stretch of the riverbed. The subsurface dam increased the volume of extractable water from the riverbed by about 2,000 cubic metres. The construction cost was free community labour for 350 days only.

4.4 Subsurface dams, whose walls are built of soil

Subsurface dam walls built of soil consist of replacing the sand laying on an underground dyke with soil taken from the riverbanks. The dam wall made of soil prevents floodwater from infiltrating in the sand and seeping downstream in the riverbed. The trapped water can be extracted from a hand-dug well sunk into the deepest part of the riverbed.

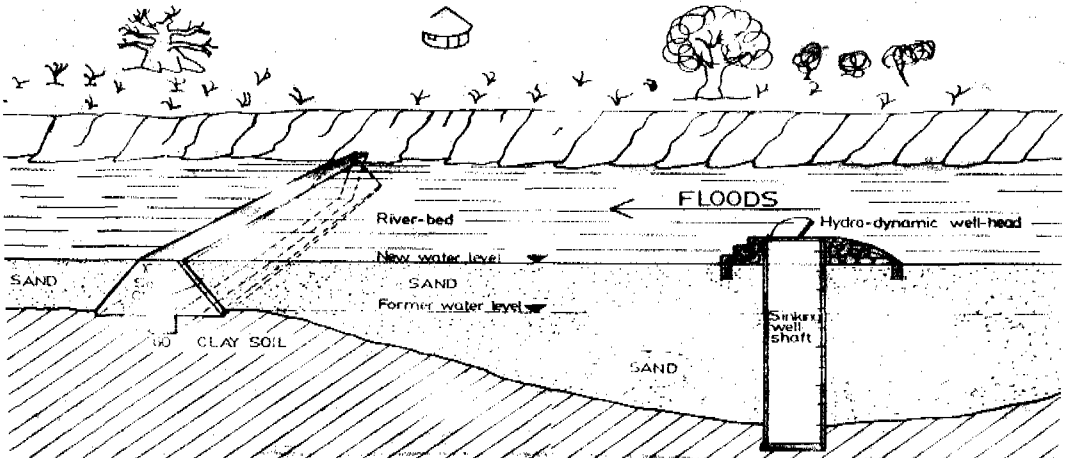

A longitudinal profile of a riverbed combined with a three dimensional view of a subsurface dam, whose wall of soil is built onto a natural dyke, and a hand-dug well sunk into the deepest part of the riverbed.

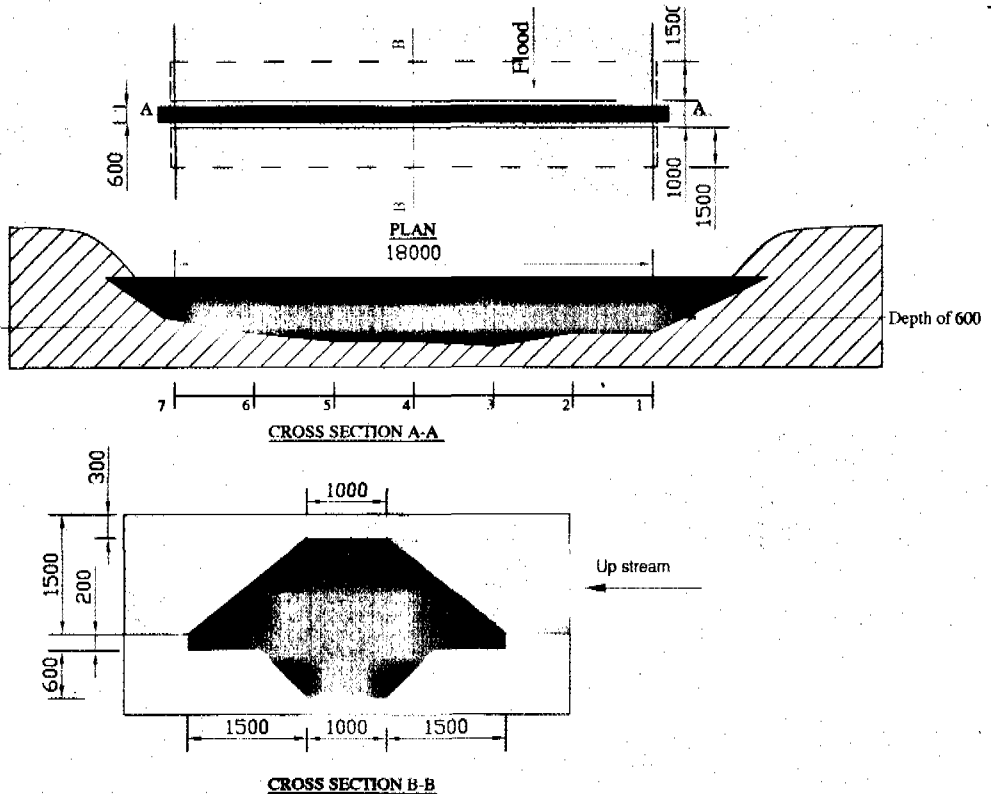

Standard design and profiles of a subsurface dam built of soil.

Construction of subsurface dams whose walls are built of soil:

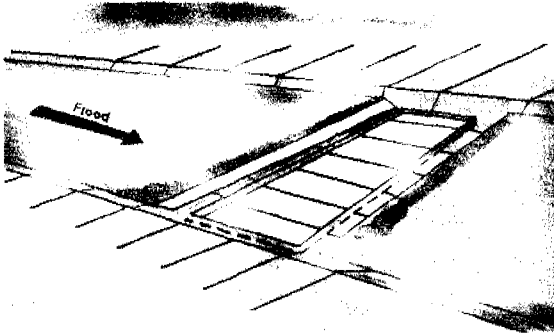

The base for the wall is cleared by removing all sand from the site in a stretch of about 2 metres wider than the base of the wall.

The width of the base is marked onto the riverbed and excavated to a depth of 20 cm into the floor of clayey soil or laterite.

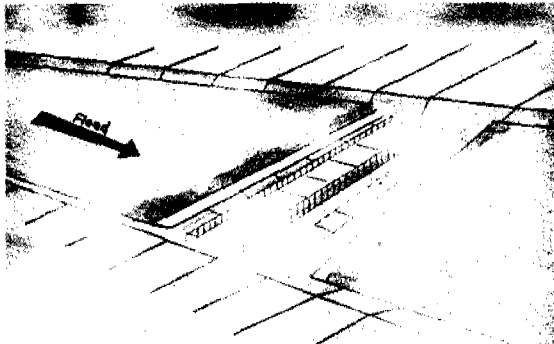

The profile of the dam wall is marked onto the riverbanks.

A key, 60 cm wide, is then excavated along the centre of the base and into the banks to a depth of at least 60 cm. Should layers of sand be found in the key, it must be deepened to 60 cm below any layer of sand.

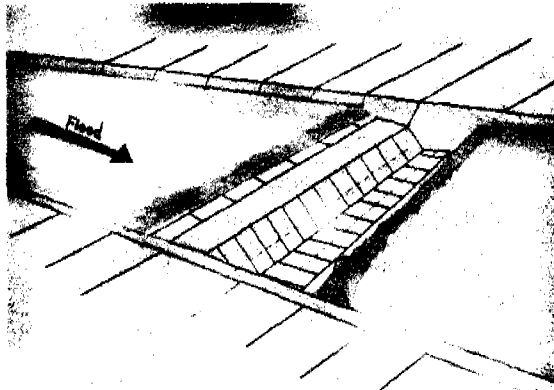

The dam wall is constructed of the most clayey soil found near the site. First the soil is compacted into the key, preferably with water. Then the wall is constructed, layer-by-layer, each 20 cm thick, of soil that is well compacted.

The upstream and downstream sides are cut to 45 degrees slope and smoothed. If the soil found for building the key and dam wall is lacking in clay content, the upstream side of the dam wall should be plastered with a layer of clay or soil mixed with dung for the purpose of making it more water proof. When the dam wall is completed, the excavated sand is back-filled.

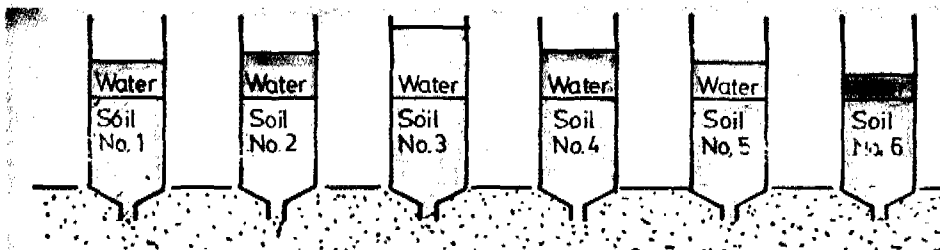

Soil can be analysed in transparent plastic bottles without bottoms and caps. Place the bottles upside down in sand and fill the bottles halfway with soil samples and top up with water. The soil with the slowest seepage, seen in Soil No. 3, is the best for building dam walls, because it has the highest clay content.

4.5 Weirs

Weirs are walls built of rubble stone masonry, or concrete, across riverbeds and into the riverbanks. Although the construction cost of weirs is higher than subsurface dams built of soil, their advantage is that the dam wall can protrude 50 cm above the level of sand in riverbeds, while dam walls for subsurface dams have to be 50 cm below the riverbed. The 1 metre difference in the height of sand in riverbeds provide a much larger storage capacity of water, which usually justifies the bigger construction cost.

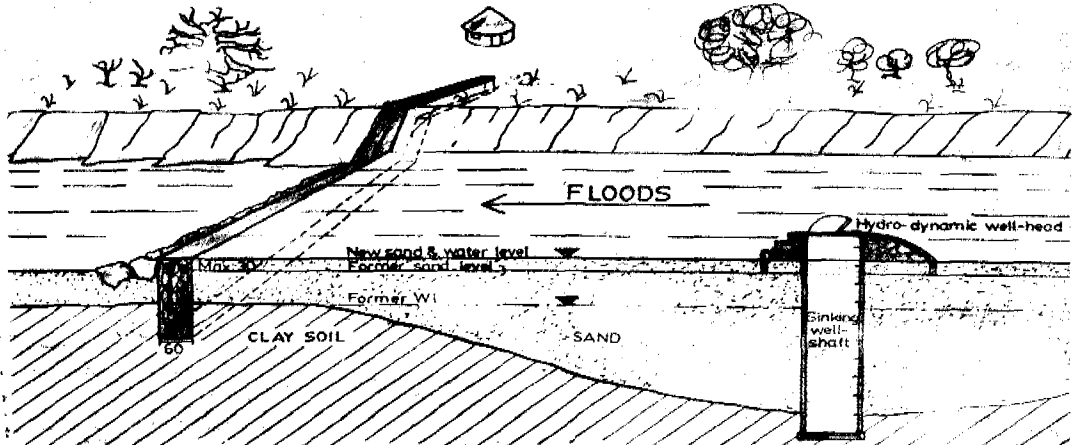

A longitudinal profile combined with a 3-dimensional view of a weir built into natural dyke and riverbank. A hand-dug well is sunk in the deepest part of the riverbed.

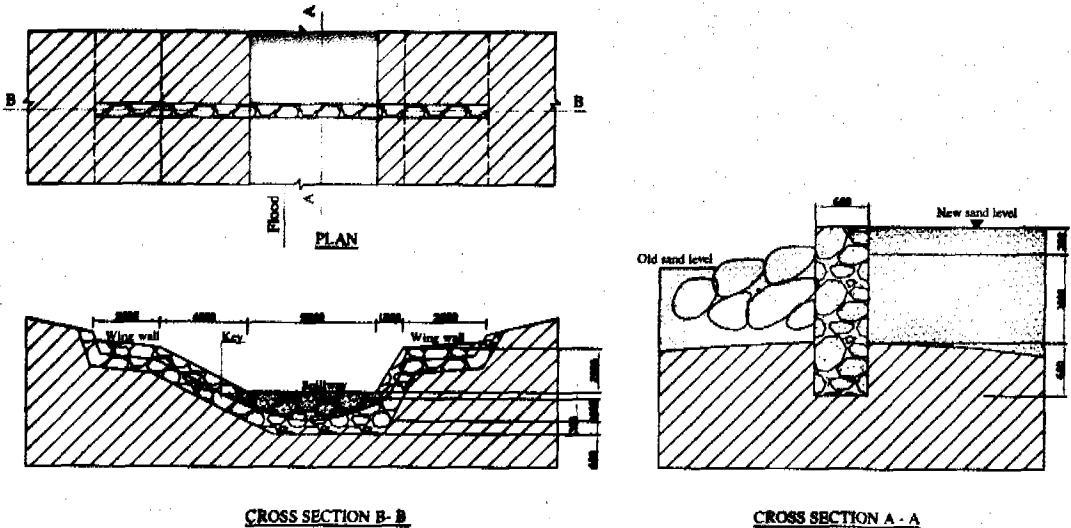

A standard design and profiles of a weir with wing walls.

The construction of this weir took 452 community working days, 105 bags of cement, 2 rolls of barbed wire, 15 tonnes of sand from the riverbed, 15 tonnes of crushed stones and 40 tonnes of large rubble stones. The construction cost was: Ksh 80,800 for survey, design and labour, Ksh 68,000 for materials and Ksh 15,300 for transport of materials. This amounts to a total cost of Ksh 164,100, plus an estimated value of Ksh 50,700 for local labour and materials. The total cost and value was therefore Ksh 214,800 in 2004.

Construction of a weir consists of the following procedure:

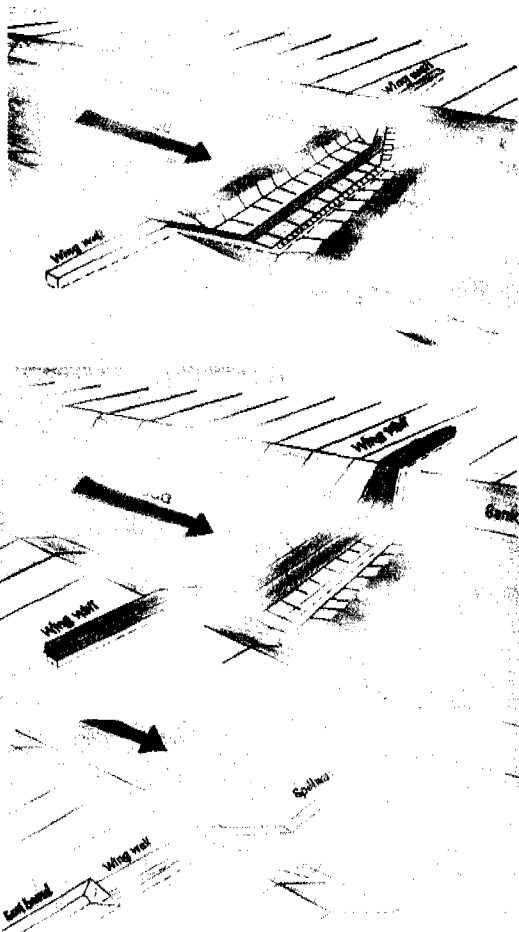

Remove the sand in a 2 metres wide stretch across the riverbed.

Excavate the key to be 60 cm wide and 100 cm below any layer of sand found in the soil of the riverbed and riverbanks.

The height of the wing walls above the riverbanks can be 60 cm only.

Wash rubble stones and compact them into a 20 cm high layer of mortar mixture of 1 cement to 4 sand, which is laid in the bottom of the key along its whole length.

Then lay 4 lengths of thick barbed wire in the key along its whole length for reinforcement of the dam wall. Continue laying 20 cm layers of mortar and compacting rubble stones into it.

Another 4 lengths thick barbed wire are laid into the mortar at 20 cm intervals before the final height of the wall.

The wall is built to 50 cm above the level of sand in the riverbed by applying mortar to flat rubble stones along the outer sides of the wall. Next day the space between the sides are filled with mortar and rubble stones.

4.6 Sand dams

Sand dams are structures that can raise the level of sand and water to several metres height far upstream of the dam wall. Sand dams are much more complicated to design and construct than subsurface dams and weirs, because of the pressure made by floods and the elevated sand and water that press against the dam wall.

As a matter of fact, most sand dams do not function well and many have been washed away by floods. However, one design has proved more successful than all the others and that is the ALDEV (African Land Development) design from the 1950s. The design criteria is based on the height of the spillway as shown on this sketch.

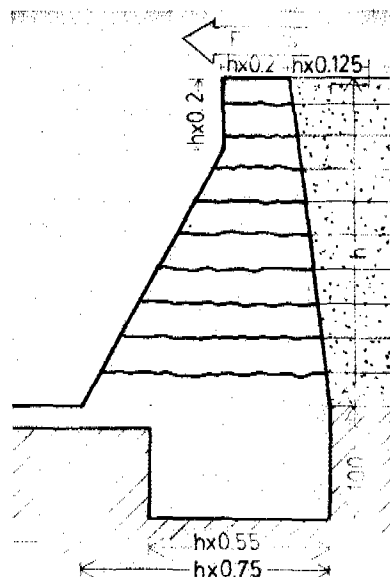

The main feature of the ALDEV sand dam is that the spillway is only raised to about 30 cm height after floodwater has deposited sand to the level of the spillway. This procedure ensures that the reservoir will consist of coarse sand from where up to 35% of water can be extracted, which is 350 litres of water from 1 cu.m. of sand.

The table below shows the percentage of water that can be extracted from the various types of silt and sand that are found in riverbeds.

	Silt	Fine sand	Medium sand	Coarse sand
Size mm	<0.5	0.5 to 1.0	1.0 to 1.5	1.5 to 5.0
Porosity	38%	40%	41%	45%
Water extraction	5%	19%	25%	35%

The table shows that only 5% of water, which is 50 litres of water, can be extracted from 1 cubic metre of silt, while 35%, 350 litres of water, can be extracted from 1 cubic metre of coarse sand.

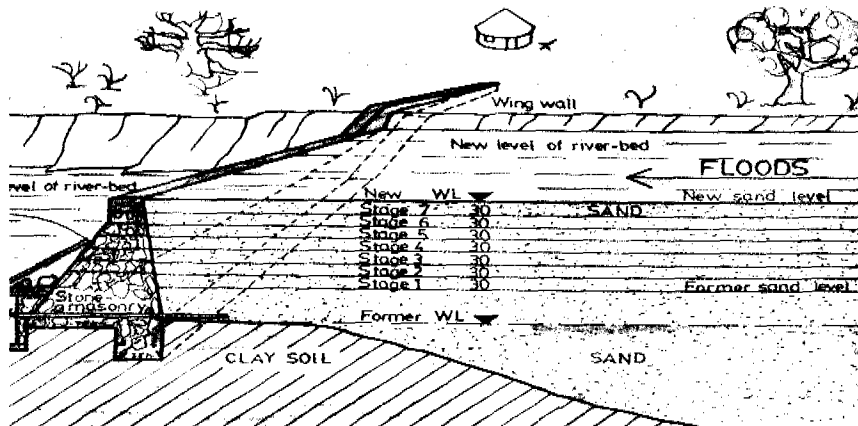

Sand dams should be filled with coarse sand from where 350 litres of water can be extracted from every cubic metre of sand. The technique of extracting coarse sand from floodwater consists of raising the spillway by 30 cm high stages above each level of sand deposited by floods.

A 30 cm high spillway traps the heavier coarse sand that rolls along the bottom of floodwater. Fine textured sand and silt, which is lighter and therefore floats in the upper layer of floodwater, will not be trapped by the spillway. When the first stage of a spillway has trapped coarse sand from a flood, a second phase of 30 cm height is added and so on until the sand dam has reached its designed height.

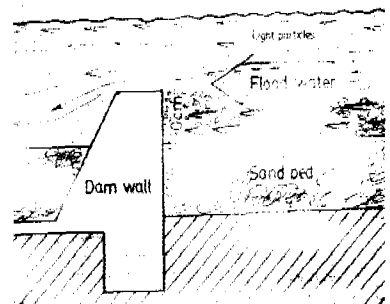

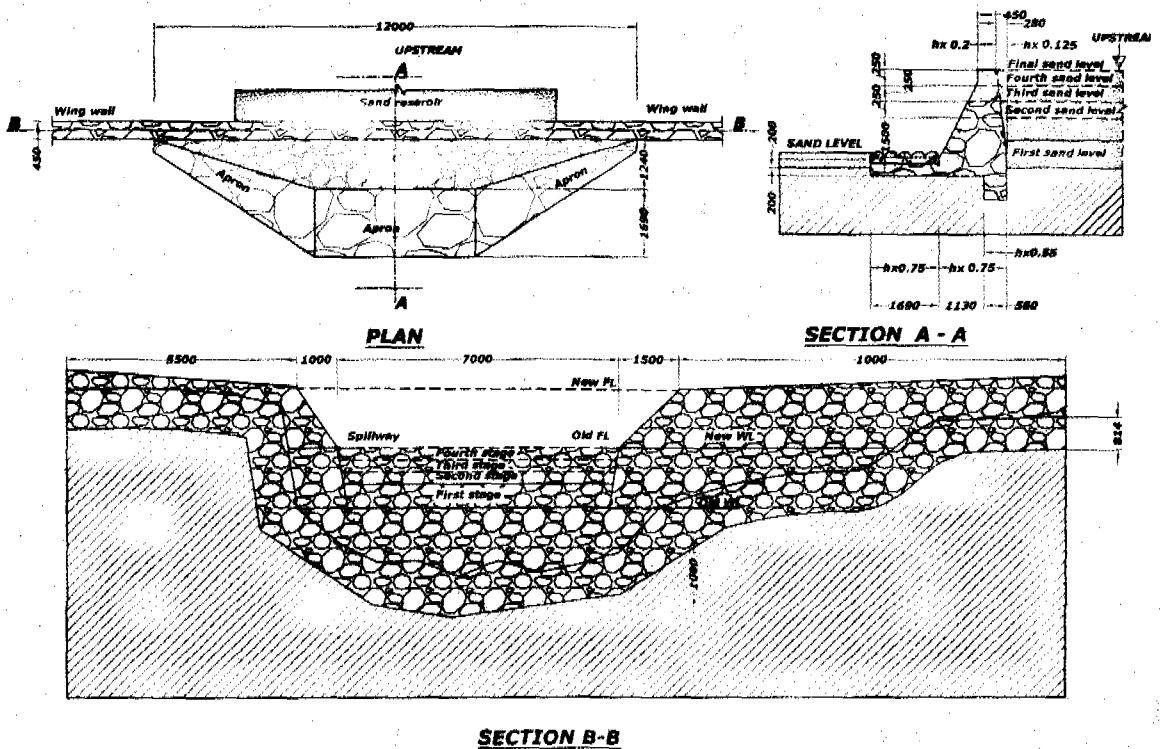

Plan and profiles of a sand dam built in Kitui in 2004.

The construction cost was Ksh 110,400 for survey, design and labour, Ksh 181,500 for materials and Ksh 55,300 for transportation of materials, totalling Ksh 347,200. In addition, the value of local materials and labour supplied free by the community was Ksh 168,350. The total construction cost was therefore Ksh 515,550 in 2004.

Construction of sand dams is implemented as follows:

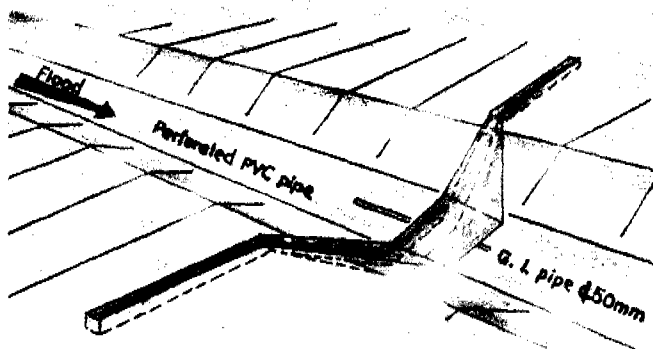

The sand is removed in a stretch of about 2 metres wider than the base of the dam wall

The base of the dam wall and spill-over apron, each of which is 0.75 of the spillway height, are excavated 20 cm into firm soil.

The key under the dam wall is excavated to a depth of 100 cm into firm soil and to the designed width of 0.55 of the spillway height. The key in the riverbanks is also excavated to a depth of 100 cm and with the same width as the base. The wing walls have a key of 30 cm and a width of 60 cm.

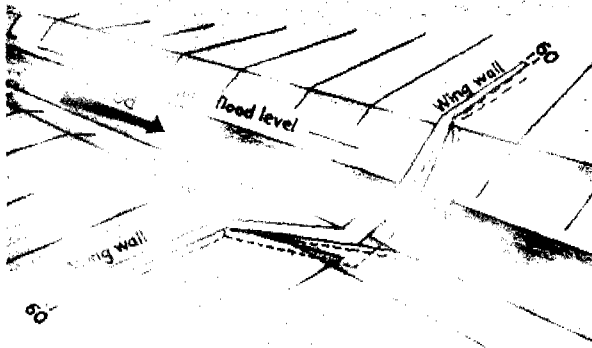

The whole length of the key is filled with concrete of mixture 1 cement, 4 sand and 4 ballast, into which washed rubble stones are compacted.

Four lengths of thick barbed wire, or iron bars, are laid into the concrete of the keys.

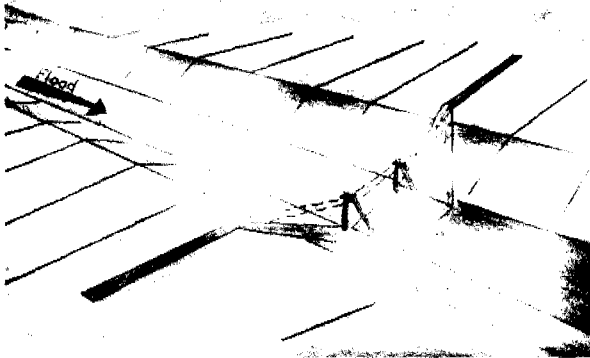

The base of the wall and apron are reinforced with concrete in a similar way but with iron bars for every 30 cm.

Two templates made of timber and having the required shape of the spillway, are erected onto the concrete floor. Strings are attached from the templates to the wing walls in order to guide the builders.

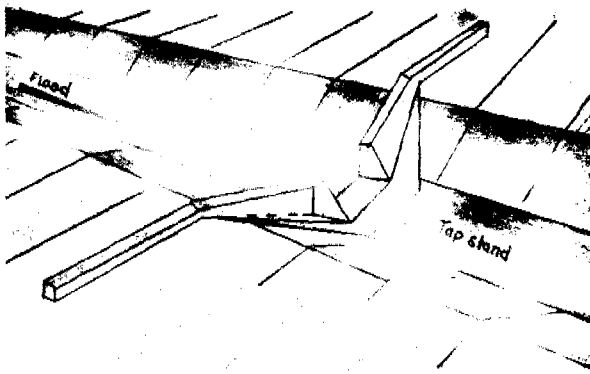

The two sides of the spillway and the wing walls are now built by mortaring flat stones along the outer walls and filling them with concrete and rubble stones the next day.

The spillway is only raised 30 cm above the level of sand in the riverbed. When flood water has deposited sand to that level, the spillway can be raised another 30 cm.

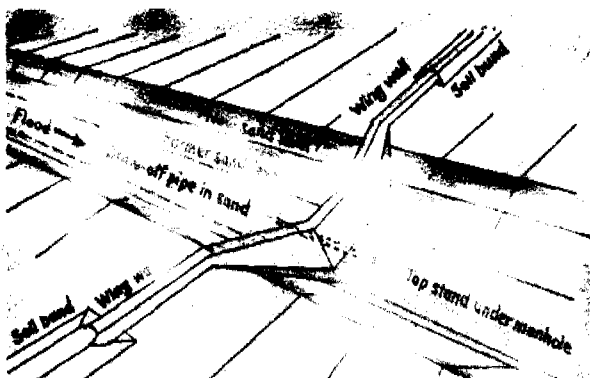

After the next flood(s) have deposited sand to that level, raise the spillway by another 30 cm and so on until the full height of the spillway has been reached.

4.8 Sand harvesting

During rehabilitation of gullies to minimize siltation of Lake Victoria implemented by RELMA/ Sida/ ASALCON in the heavily eroded land between Katitu and Homa Bay, 11 sand dams were constructed across gullies together with Kusa Community Development Group.

The income from selling coarse sand for construction works paid back the construction cost within 18 months.

The sand dams were constructed according to the ALDEV design with the spillway raised in stages of 30 cm height after floods had deposited sand upto the height of the spillway.

Unfortunately, people dug deep holes in the sand reservoirs instead of harvesting only the recommended 30 cm top layer of the sand, which would have been replenished by the next flood. The result was that the deep excavations were refilled with silt instead of sand, which nobody wanted to buy.

In order to restore the good business, the spillways of the sand dams were cut down to 30 cm above the original level of the gullies. This drastic technique allowed the next flood to wash out all the silt in the reservoirs. The community were trained once more in closing the spillways in 30 cm high stages and to harvest only the top layer of sand.



A gully before a sand dam was built at Kusa.

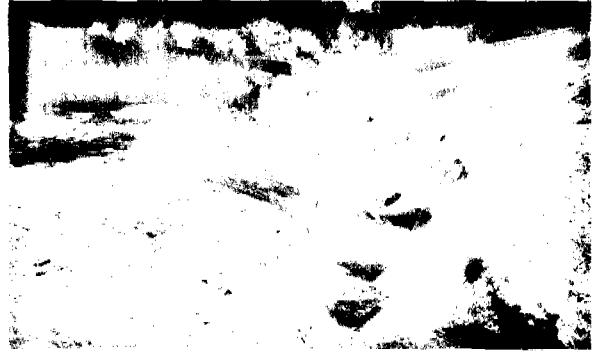

The first stage of a spillway being 30 cm high.



One of the completed sand dams at Kusa.



Sand harvesting from a sand dam.

4.9 Gold and gemstones from sand dams

UNDP and ASALCON trained engineers and technicians to survey, design and construct subsurface dams, weirs and sand dams in the Dry Zone of Burma in 1994.

During a follow-up visit to the dams in 1995, people were washing gold out of the sand dam.

In Eastern Kenya, rubies are found in sand dams near a volcanic hill.



Gold being washed out of a sand dam in Burma.

In Western Kenya, sand bags were placed across streams and gold was found just upstream of the barriers.

The explanation for these additional benefits of sand dams, is that gold and gemstones are heavier than the other materials that floodwater transports downstream in riverbeds. When floodwater passes over the almost level surface of the reservoirs of sand dams, the velocity of the flowing water is reduced with the heaviest material, such as gold and gemstones settle down into the sand of these dams.

4.10 References on subsurface dams, weirs and sand dams

- Dying Wisdom.* Centre Agarwal, A. and Narain, S. 1991 for Science and Environment, India.
- Groundwater arresting sub-surface structures.* Ahnfors, O. 1980. Sida/ Govt. of India.
- Sand storage dams for water conservation.* Burger, S.W. 1970. Water Year 1070. S. Africa.
- Water Quality Data Book.* Faillace, C. and E.R. 1987. Water Development Agency, Somalia.
- The feasibility of Sand Dams in Turkana.* Fewster, E. 1999. Loughborough University, UK.
- Underground dams in arid zone riverbeds.* Finkel & Finkel Ltd. 1978. Haifa, Israel.
- Underground water storage in Iran.* Finkel & Finkel Ltd. 1978. Haifa, Israel.
- Rainwater Catchment Systems.* Gould, J. and Nissen-Petersen, E. 1999. IT Publications, UK.
- Field Engineering for agricultural development.* Hudson, N.W. 1975. Oxford, UK.
- Field Engineering.* Longland, F. 1938. Tanganyika.
- Storage of groundwater behind sub-surface dam.* Newcomb, R.C. 1961. US Geol. Survey. US
- Groundwater Dams for small-scale water supply.* Nilsson, A. 1988. IT Publications. UK.
- Rain Catchment and Water Supply in Rural Africa.* Nissen-Petersen, E. 1982H & S, UK.
- Subsurface dams and sand dams.* Nissen-Petersen, E. and Lee, M. 1990. Danida Kenya.
- Subsurface and Sand-storage Dams.* Nissen-Petersen, E. 1995. UNDP/Africare, Tanzania.
- Harvesting rainwater in semi-arid Africa.* Nissen-Petersen, E. 1990. Danida, Kenya.
- Ground Water Dams in Sand-rivers.* Nissen-Petersen, E. 1996. UNCHS, Myanmar.
- Water from Sand Rivers.* Nissen-Petersen, E. 2000. RELMA/Sida, Kenya.
- Water from Dry Riverbeds.* Nissen-Petersen, E. 2006. Danida, Kenya.
- Where there is no water.* Mutiso, G. and Thomas, D. 2000. SASOL, Kenya.
- Subsurface dams and its advantages* Raju, K.C.B. 1983. Ground Water Board, India.
- Ephemeral rivers in the tropics.* Sandstrom, K. 1997. Linkoping University, Sweden.
- Sub-surface dams* Slichter. 1902. USGS Water Supply and Irrigation. USA.
- The storage of water in sand.* Wipplinger, O. 1958. Water Affairs, South West Africa.
- Sand storage dams in South-West Africa.* Wipplinger, O. 1974. South Africa.

Chapter 5. Run-off farming

5.1 Drainage from roads by engineers

Rainwater run-off from rural roads usually finds its own way into the bush or the farmers' fields, where it creates gullies and causes other damage, before it ends up in the sea or in underground aquifers, maybe hundreds of kilometres away.



Natural drainage from the lowest point of a road.

Fortunately, road engineers are nowadays becoming much more aware of the possible negative environmental impact of roads.

This photo shows an ideal situation: A road grader has cut a furrow that drains run-off water into a murrum pit, where it can be used for watering livestock and, perhaps, irrigation of a garden or tree nursery.

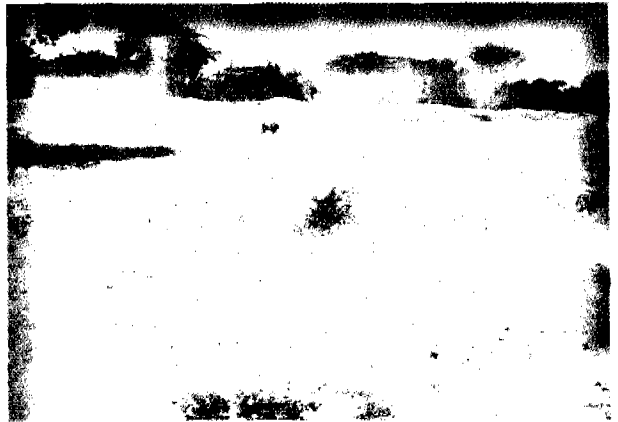

A graded furrow drains water into a murrum pit.

This photo shows another useful solution: A culvert drains run-off water into a murrum pit, instead of spilling its water into a gully, which would erode more and more for each year.

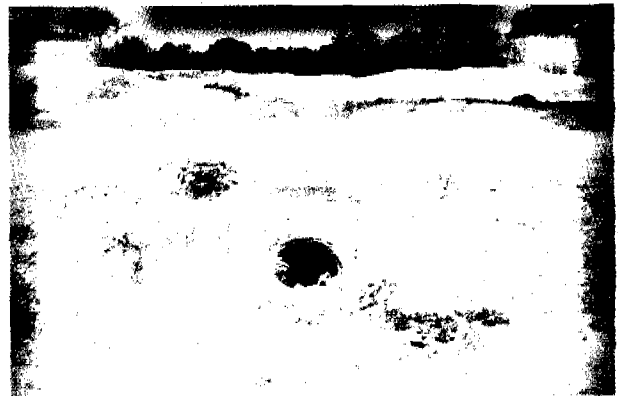

A culvert draining run-off water into a pond.

5.2 Drainage from roads by farmers

A farmer in the semi-desert Somaliland has made a small bump on the road and a slightly sloping soil bund, that together drain rainwater from the road into his sorghum field, which is the only crop growing in the area.

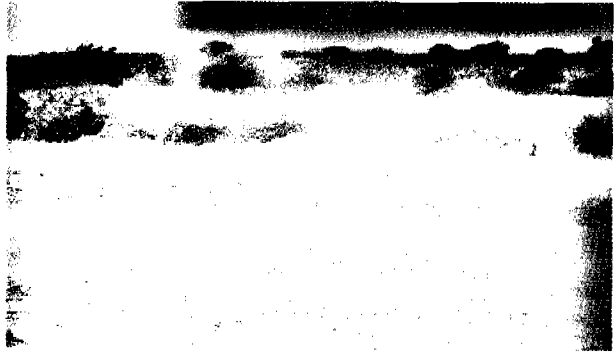

Bump and drain cut manually to irrigate a field.

A farmer in Kitui has excavated a ditch that diverts run-off water from a road into a murrum pit, which has been converted into a small dam.



A ditch draining run-off water into a reservoir.

Soil bunds should have a gradient that allows the silt to be deposited into a ditch before the water reaches the water reservoir.

In sandy soil, the slope should be 3:100, i.e. 3 cm depth for every 100 cm length. In clayey soil the slope should only be 2:100.

A gradient of 3:100 can be marked onto the land by tying a long transparent hosepipe onto 2 long sticks that are both marked at the height of 100 cm.

Place the first stick at the ditch next to the road, and the second stick exactly 10 m down towards the murrum pit.

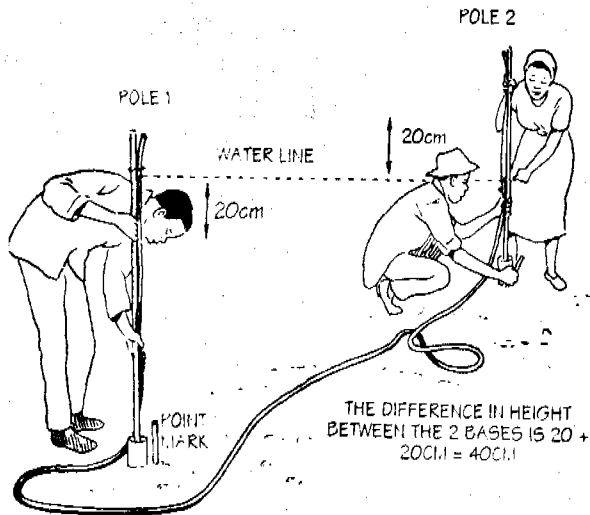

Fill the hosepipe with water until the water level reaches the 100 cm mark on the first stick. Then move the second stick sideways until the water level in the pipe is 30 cm above the 100 cm mark, which gives a gradient of 3:100 (30 cm:100 cm = 3:100). Repeat this exercise every 10 metres until the final point is reached.

Another tool for marking contour (horizontal) lines and gradients on land is called the *A-frame*. An A-frame is made of 3 long sticks having the same length of 2.5 m. Two of the sticks are tied together at the top.

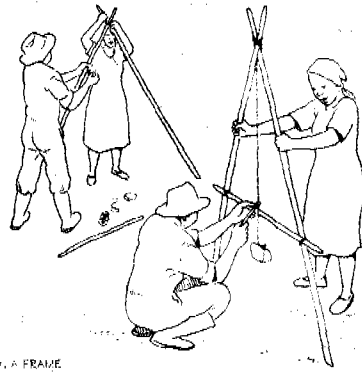

MAKING AN A-FRAME

The third stick is tied to the first two sticks so that its two ends are exactly at the same distance from the ground. The exact centre of this stick is marked onto it. A stone is hung on a string tied around the joint of the first two sticks.

When the string is aligned to the mark on the horizontal stick, the two legs of the A-frame stand on horizontal ground.

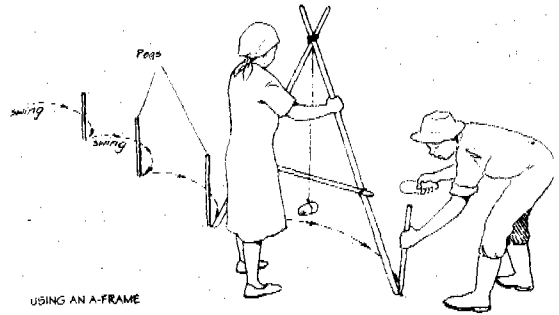

USING AN A-FRAME

A long horizontal line is pegged out as shown in the sketch on the right.

If a gradient line is to be marked on the land, then the mark is changed as shown on this sketch.

A gradient of 2:100 is found by placing the A-frame on a 2 m long timber that is placed on horizontal ground with one end lifted 4 cm from the ground.

The position of the string is marked on the stick and that mark is used for setting out the gradient of 2:100 in the field.

A gradient of 3:100 is found by lifting one end of the timber 6 cm off the ground and marking the position of the string onto the stick.

A contour (horizontal) line is being marked in the field

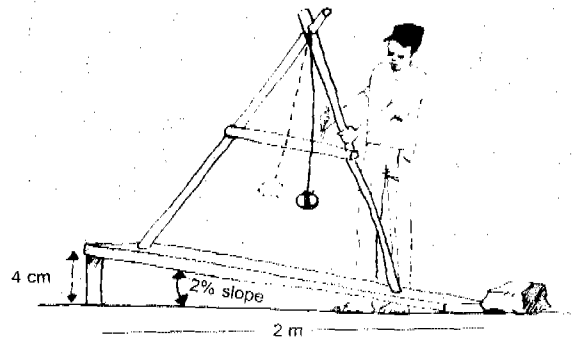

An A-frame is being adjusted to mark a gradient line of 2:100 onto a field.

A third method of setting out contour lines consists of tying a spirit level to the middle of a string with each end tied onto 2 sticks of exactly same height and spaced 10 m apart.



Three farmers are setting out a horizontal line.

When the air-bubble in the spirit level is exactly in the middle, the sticks are then standing on horizontal ground.

If a gradient of 3:100 is to be marked, then the 10 m long string is tied 30 cm lower than the other stick. For a gradient of 2:100, the string on one stick must be 20 cm lower than on the other stick.

A fourth method is to sight along two water levels in a circular transparent hosepipe that is half filled with water.



Two farmers are using circular transparent hosepipes filled halfway with water to sight horizontal lines.

To find two horizontal points, one person sights along the two water levels in the pipe towards another person with the same eye height, while this person moves up or down until their eyes are at the same level.

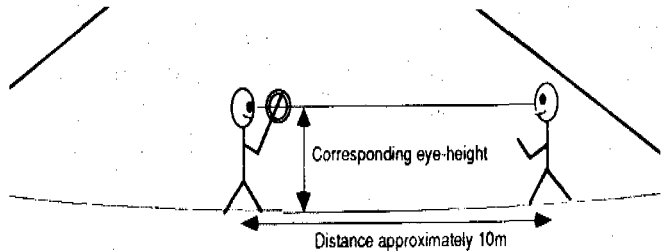

To mark a gradient of 3:100, measure 30 cm down from the other person's eyes and mark the point at his/her clothes. Then the two persons hold a 10 m long string between them while the first person sights towards the point marked on the second person who moves up or down until the two water levels align with the marked point on the second person. When that point is reached, the gradient is 3:100 on that 10 m stretch.

5.3 Soil bunds

Soil bunds are used for transporting run-off water from a catchment area, such as a road, into either a murrum pit, an earth dam or a ground tank or for seasonal irrigation of fields.

Fruit trees and bananas can be grown in the bottom of soil bunds, while fodder grasses and multi-purpose scrubs and trees can be planted on the banks of excavated soil.

In this photo, the soil bund has to be cleaned of banana debris before it can divert run-off water to the far end of the field where it is needed for seasonal irrigation.



Bananas and papaya growing in a soil bund, while sisal and kei apple mark the boundary by growing on the downstream bank.



Bananas growing a soil bund.

Soil bunds can also be made on steep land if the velocity of run-off water is slowed by means of large stones placed across the soil bunds. Such barriers are called *check dams*.

It is advisable to plant creeping grass between the stones of check dams because it "concretes" the stones together as seen in the photo.

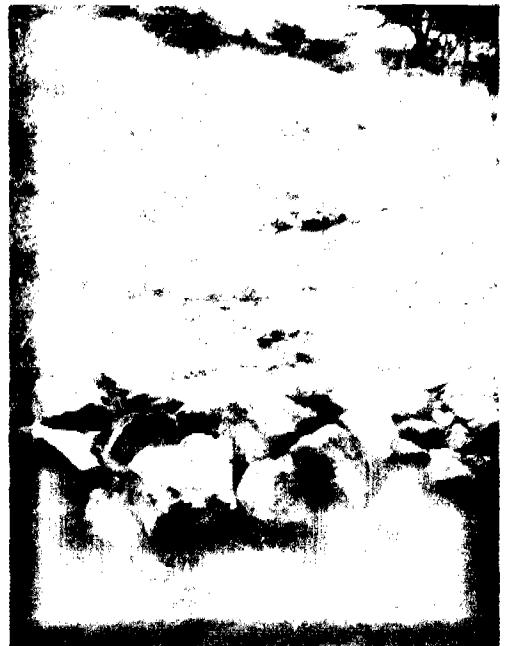

5.4 Gullies

Rainwater running off catchments, such as roads, starts as *sheet erosion* that might enlarge to become *rill erosion*, which might develop into gullies.

Gully erosion causes much damage to fields and should therefore always be stopped at an early stage by means of *check dams*.



A simple check dam can be made by placing large stones across a shallow gully as seen in this photo from Somaliland. However, the wing walls were not high enough, and floodwater has “eaten” away parts of the two banks and has by-passed the check dam.

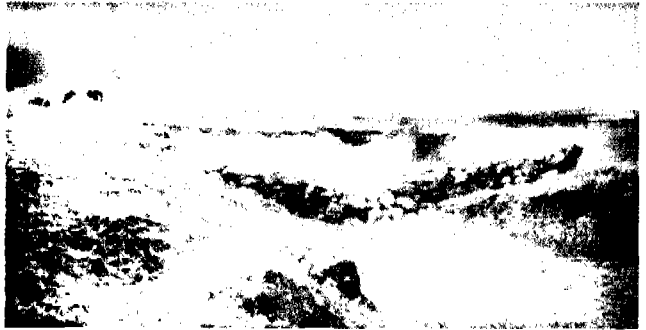

The check dam seen in this photo from Dodoma, Tanzania is made correctly. The two wing walls are high above the spillway in the centre of the check dam and floodwater passes over the spillway while depositing silt and soil in the gully upstream of the check dam.

This sketch shows a series of check dams correctly built of square stones or blocks laid across a long gully.

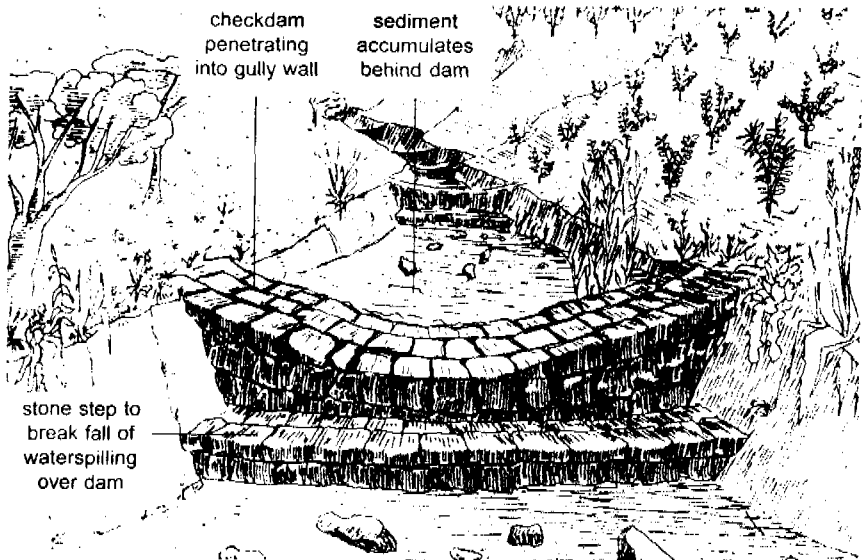

These two sketches give some measurements on building check dams of rubble stones in gullies.

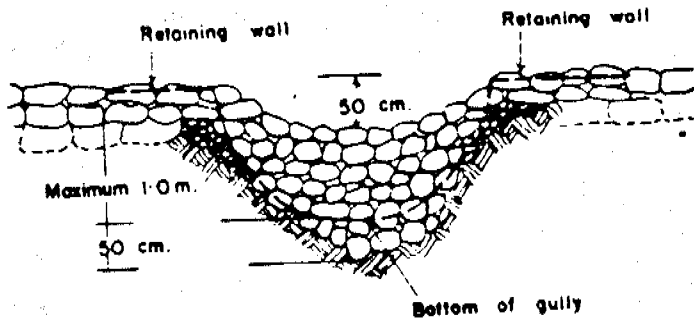
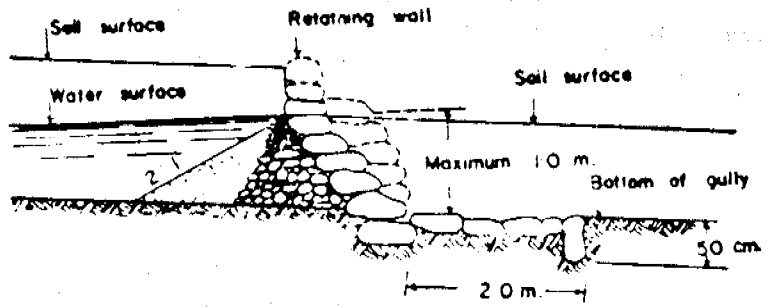

This sketch shows another type of check dam constructed with *gabion weirs*, which consist of boxes made of galvanized iron mesh that have been filled with all sizes of rubble stones.

Although gabions are efficient, they are rather expensive to make and they must be transported to the site, thereby adding to the cost.

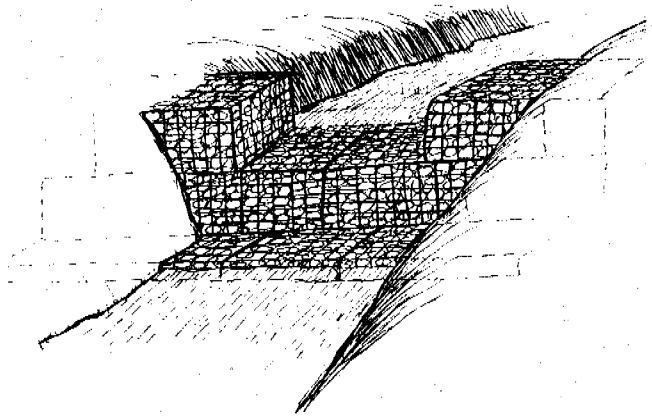

Plastic bags filled with soil and stones are much more affordable than gabions.

This check dam made of sand bags and a spillway excavated into one of the two banks was built in a deep gully near Lake Victoria. The first flash flood had just passed. Silt and water are deposited in the gully, while surplus water was discharged over the spillway.



A check dam made of sand bags in a deep gully.

After a few flash floods more, grass has “concreted” the sand bags into a dam wall. The gully is almost filled with fertile silt and green vegetation is growing on the banks of the former gully.



After a few rain showers the gully is healed.

Nearby another farmer built a simple sand dam across a deep gully. The main purpose of the dam is to harvest sand for sale. A secondary purpose is to protect his farm land being consumed by the gully.

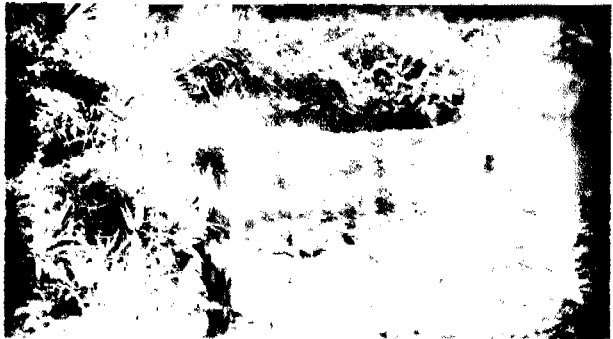

Another 10 sand dams were built in the area for sand harvesting and gully control. The construction cost of these dams was recovered by selling sand for 18 months only.



Another type of check dam is the *masonry weir*. Weirs are constructed of either concrete or rubble stone masonry.

The main purpose of this weir seen in the photo was to provide water for the *Dream Camp*, now the *Base Camp* at the Talek River running along the Masai Mara Game Park, Kenya.

An additional advantage of the improved water supply was that the vegetation turned so lush upstream of the weir that birds, hippos and crocodiles settled down there.

To improve the environment even more, which attracts tourists and environmentalists, weir was enlarged to become a sand



The weir built across the Talek River.

An aerial photo taken in October 2006 of the sand dam built over the weir in the Talek River shows the difference made to the environment.

The vegetation is green, large and lush upstream of the sand dam (upper centre of the photo) while there is very little vegetation downstream of the sand dam (lower centre and left side of the photo).

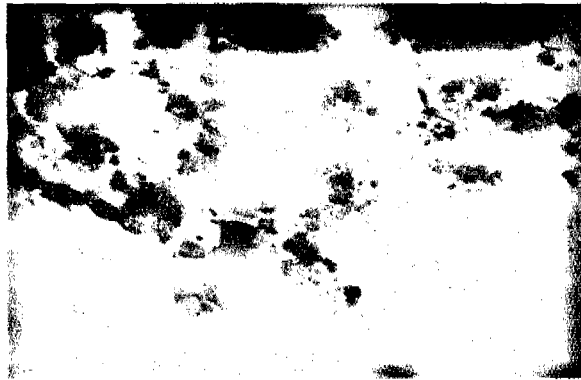

An aerial view of the sand dam in Talek River in October 2006.

Most dry riverbeds and gullies could be turned into good water sources and that would improve the environment by the simple means of check dams, subsurface dams, masonry weirs and sand dams described above.

5.5 Macro-irrigation

Roads are excellent catchment areas. Due to their hard surface, 1 km of a narrow 4 metre wide road can produce about 1,000 cubic metres of water from a rainfall of 300 mm only.

This large volume of water can be used productively instead of the damage it is doing to fields, gullies, riverbeds, rivers and the sea itself where the siltation destroys bathing and fishing areas and the coral reefs.

The following macro-irrigation schemes are based on the techniques that were used in the Negev Desert in Israel some 3,000 years ago. Some of the macro-irrigation systems, which have been replicated at Kibwezi, Baringo and a few other arid and semi-arid places in Eastern Kenya, are presented briefly in this section. More detailed information can be found in the References in this handbook.

This sketch shows how run-off water from a road was diverted into a valley at Kibwezi for the purpose of providing domestic water and growing fruit trees, crops, etc.

A series of stone and soil bunds were built across the valley. Each bund had a spillway to allow surplus water to spill over into the next bund without causing erosion.

Hand-dug wells sunk between and below the bunds supply water for garden irrigation and domestic water during dry seasons.

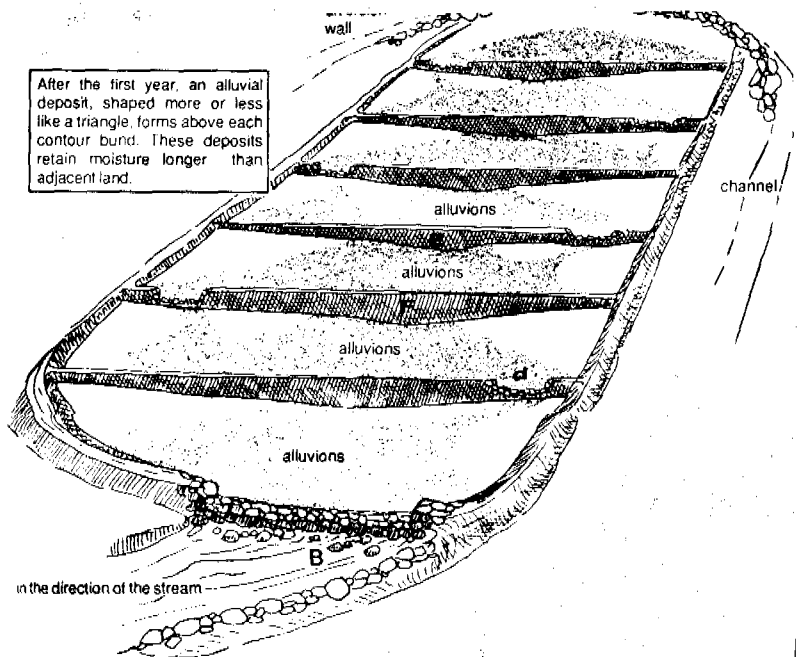

Almost similar schemes, as shown on this page, were implemented in Baringo and a few other places.

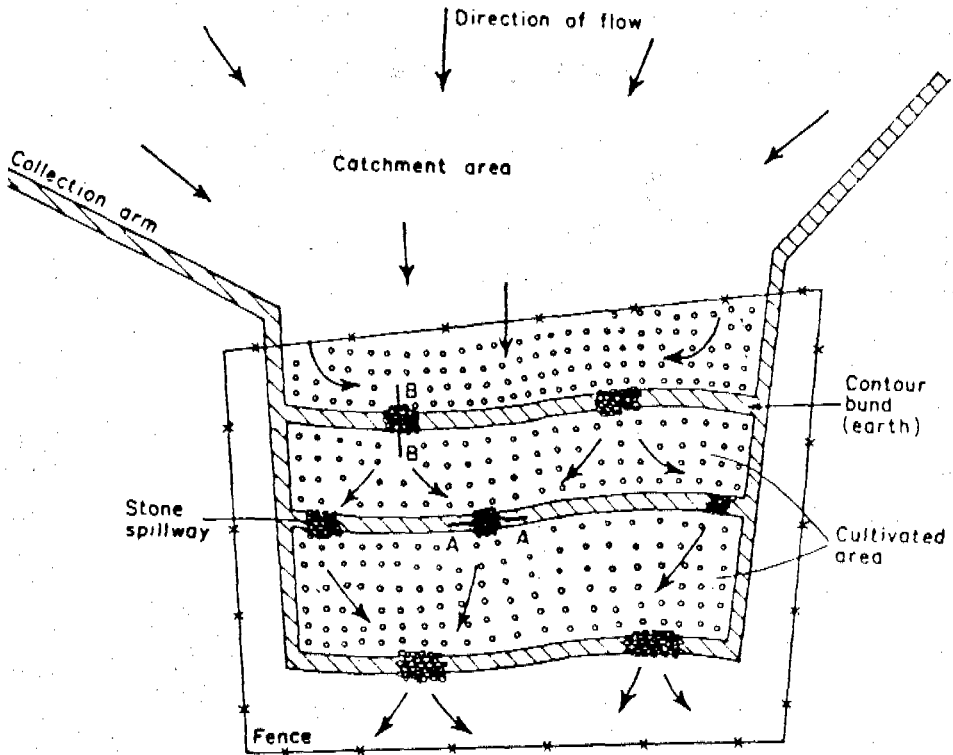
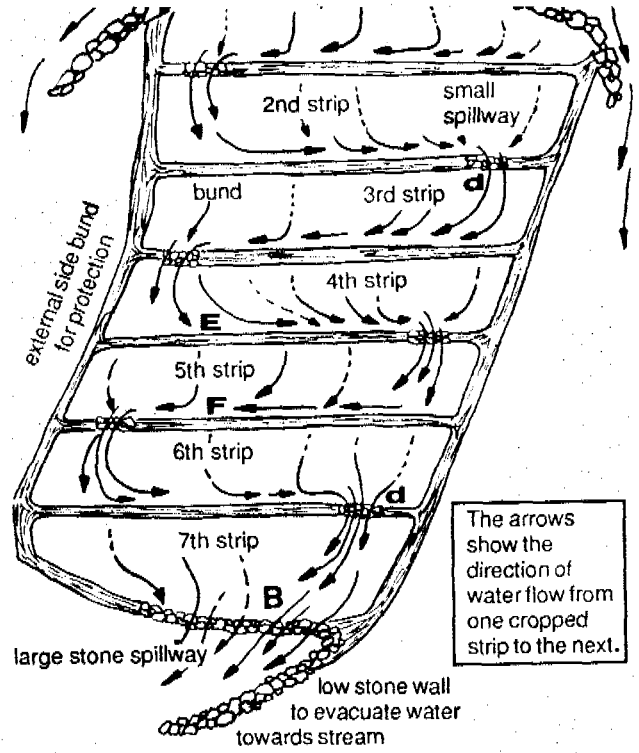

5.6 References on run-off farming

Dying Wisdom. Anil Agarwal and Sunita Narain. CSE, India 2003.

Land and Life. . Hugues Dupriez. Philip DeLenener. Macmillan Publisher, U.K.

Looking after our land. Will Critchley. Oxfam, U.K. 1991.

Managing land. Technical Handbook No. 36. RELMA/Sida. 2005.

Production without Destruction. H.L. Vukasin, L. Roos, N. Spicer. M. Davies. Zimbabwe

Soil Conservation in Arusha Region, Tanzania.

The Negev. Michael Evenari, Leslie Shanan, Naphtali Tadmor. Harvard University USA.

Vanishing Land and Water. Jean-Louis Chleq, Hugues Dupriez. Macmillan Pub. U.K.

Ways of Water. Hugues Dupriez. Philip DeLenener. Macmillan Publisher, U.K.