

EXTRA-STRONG ROPE PUMP

MANUAL OF TECHNICAL DRAWINGS

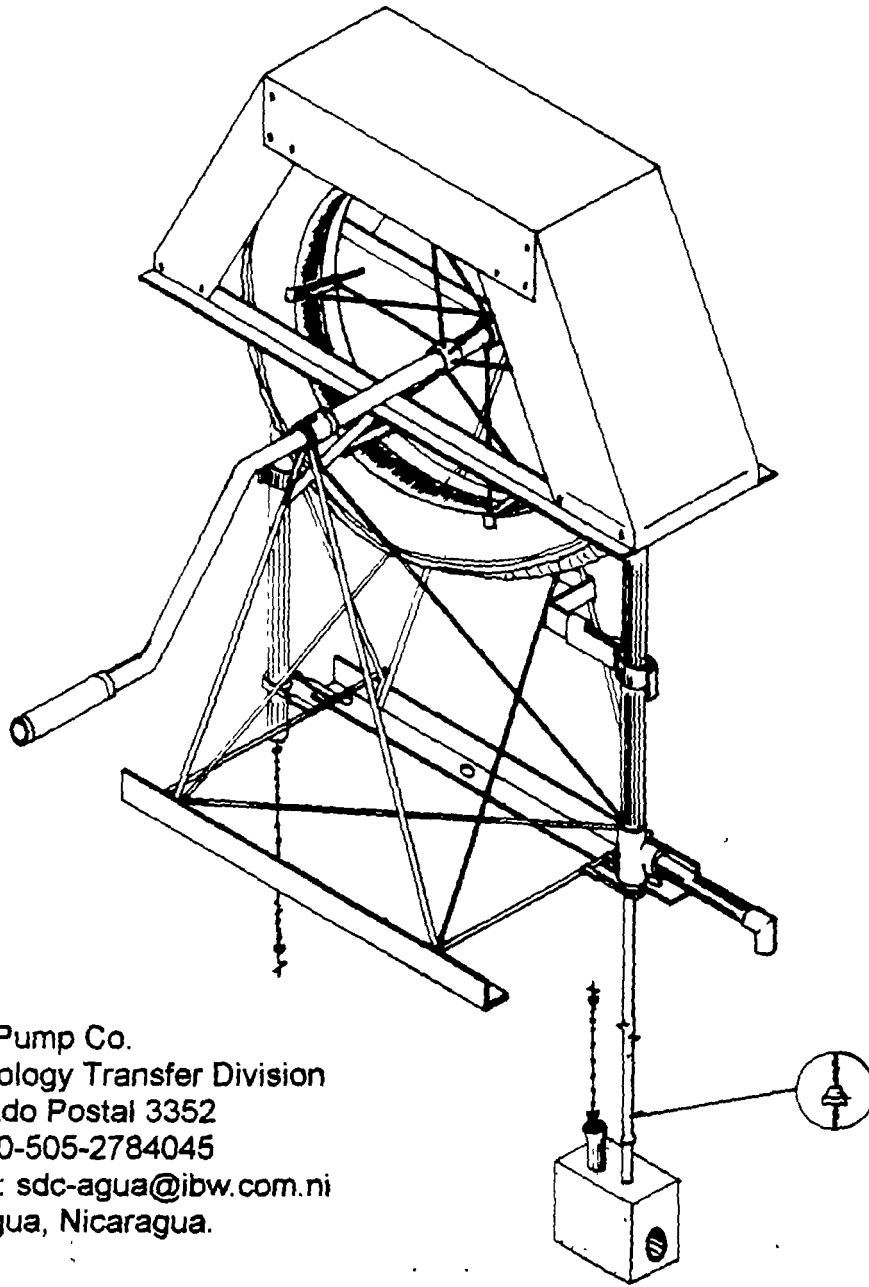

Rope Pump Co.
Technology Transfer Division
Apartado Postal 3352
Fax: 00-505-2784045
E-mail: sdc-agua@ibw.com.ni
Managua, Nicaragua.

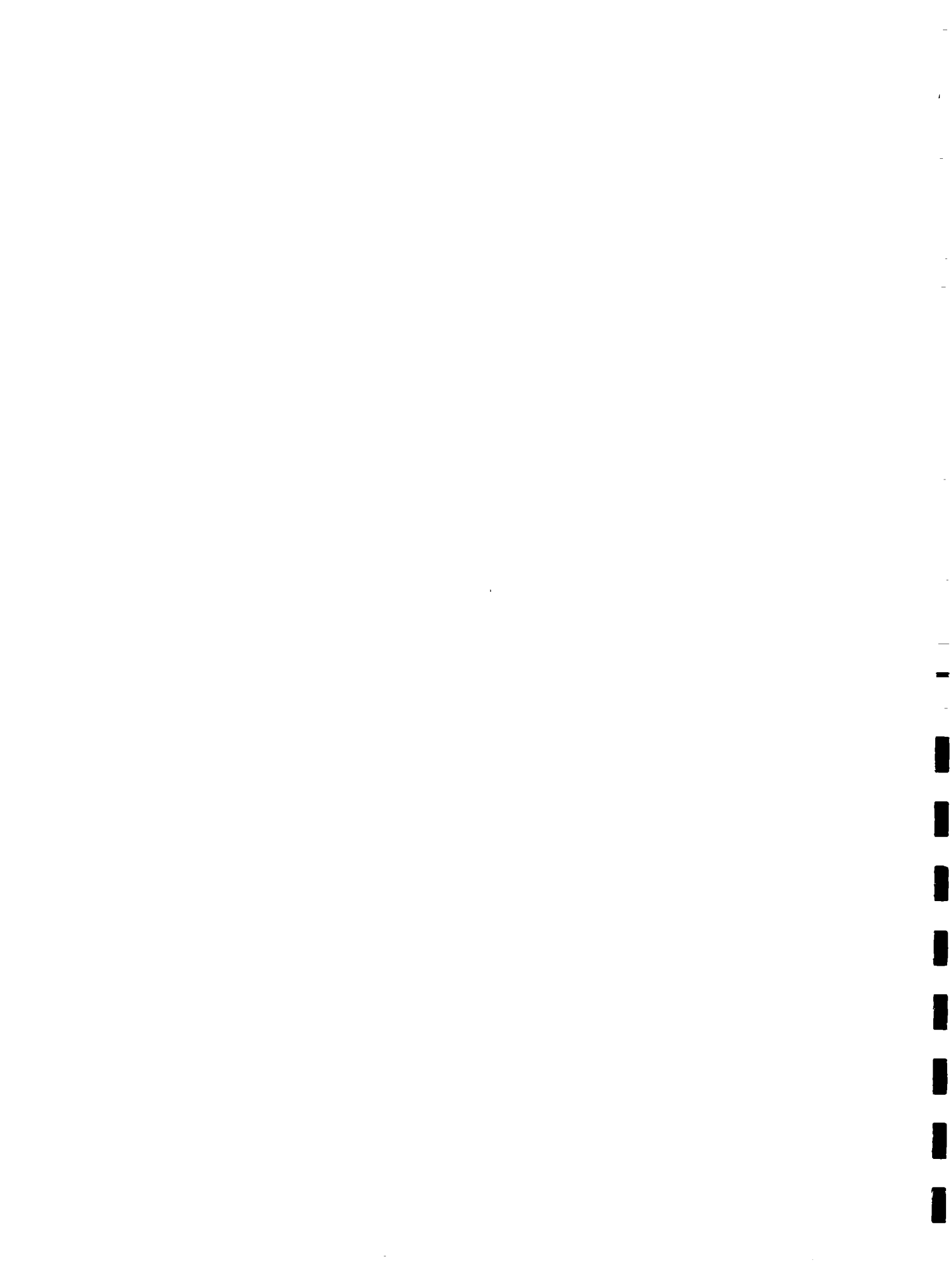

EXTRA-STRONG ROPE PUMP

MANUAL OF TECHNICAL DRAWINGS

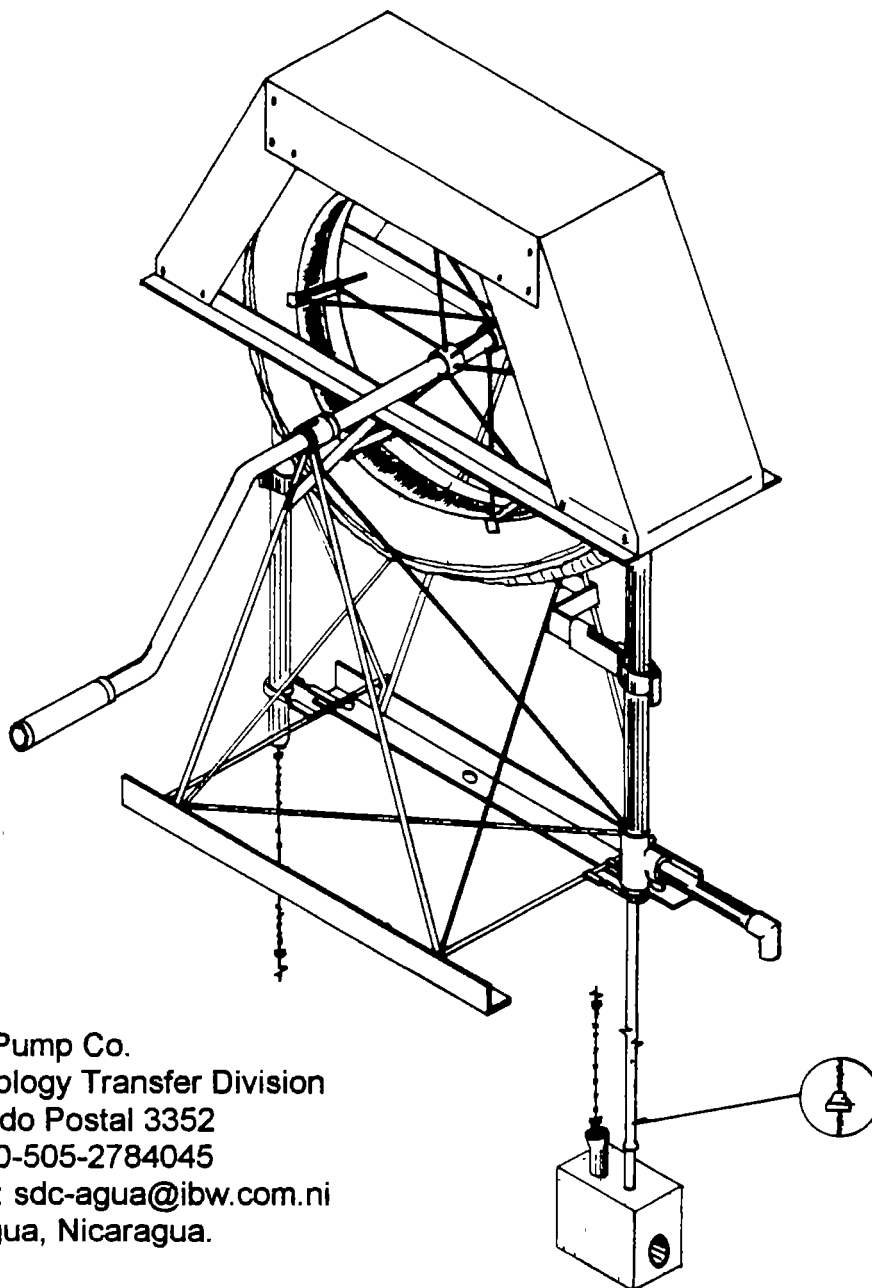

Rope Pump Co.
Technology Transfer Division
Apartado Postal 3352
Fax: 00-505-2784045
E-mail: sdc-agua@ibw.com.ni
Managua, Nicaragua.

LIBRARY IRC
PO Box 93190, 2509 AD THE HAGUE
Tel.: +31 70 30 689 80
Fax: +31 70 35 899 64

BARCODE: 14980

LO:

232.2 97 DO (FOLDER)



MANUAL OF TECHNICAL DRAWINGS

EXTRA-STRONG ROPE PUMP

CONTENTS

- I- PRESENTATION
- II.- EQUIPMENT CHARACTERISTICS
- III.- PUMPING CAPACITY
 - A- PISTONS AND ROPE
 - B1- GUIDE BOX INTERNAL PIECE
 - B2- GUIDE BOX
 - C- WHEEL STRUCTURE
 - C.a CRANK PRODUCTION
 - C.b LEG ASSEMBLY
 - C.c LEG REINFORCEMENT
 - C.d ANGLE IRONS
 - C.e PULLEY WHEEL HUB
 - C.f BRAKE SYSTEM
 - C.g UPPER AND LOWER SUPPORTS
 - C.h COVER FRAME
 - C.i WHEEL COVER
 - D- INSTALLATION ACCESSORIES

II.- EQUIPMENT CHARACTERISTICS

- Appropriate technology equipment effective at a depth of 50 meters.
- Produced with accessible materials.
- Maintenance and repair do not require expertise and complex tools.
- Easy to handle.
- Easy to install.
- Its relatively low cost makes it accesible to the rural population.
- Preserves the quality of the water and the population's health.



I.- PRESENTATION

This manual of technical drawings is part of the rope pump technology transference programme. It has as its goal to show in a clear and detailed manner the essentials of each component of this useful hand pump.

In addition to the current manual, the programme prepared manuals of the family well rope pump and the community well rope pump. Their respective front page is shown in the back of this manual.

Each component is presented here with its corresponding measures, a list of all the necessary production materials, and complementary technical information.

In March 1996, the Governments of Nicaragua and Switzerland - through COSUDE - signed a new three-year bilateral cooperation agreement by which the INAA-COSUDE programme activities are to continue for the 1996-1998 period. Within the framework of this agreement, the transference of rope pump technology seeks to promote rope pump production at the regional and international levels. The Technology Transfer Division of the Rope Pump Company will be in charge of carrying out the aforementioned production activities. The Division is provided technical consultancy services through the Dutch Ecumenic Development Cooperation Organization known as "Servicio Ultramar" ("Overseas Services") or DOG (for "Dienst Over de Grenzen").

This is an easy-to-understand document and is aimed at future producers, cooperation organizations working in the field of water and sanitation, and other persons interested in the rope pump technology.

Together with the rope pump production photomanual and the document "Experiences and Tolerances", this manual provides all the information necessary to carry out technology transference activities at the international level.

This Manual has been prepared by the Technology Transfer Division of the Rope Pump Company. It can be freely reproduced.

Los Cedros, Province of Managua, Nicaragua. 4 August 1997.



III.- PUMPING CAPACITY

PUMPING CAPACITY

Depth (meters)	Adults (Liters/min)	Children (Liters/min)	Time needed for an adult to fill a barrel (min)
5	70	39	3
10	41	19	5
15	27	13	8
20	20	10	10
25	16	8	13
30	14	6.5	15
35	12	5.5	18
40	10	4.8	20



A- PISTONS AND ROPE

- Piston diameter is determined by the type of pipe to be used and the well's depth. Pistons should be made of injected polypropylene or polyethylene. Neither rubber nor wood are recommended.
- Five different piston sizes are used.
- The rope's length, diameter and amount of pistons are determined by the well's depth.

Length and diameter variations for both the pistons and the rope

		Depth (meters)			
Component part	Unit	0 - 11	11 - 19	19 - 29	29 - 40
Piston nominal diameter	inches	1	3/4	1/2	1/2
Rope length	Meters	27	43	63	85
Rope diameter	inches	1/8	1/8	1/8	1/4
Amount of pistons	unit	26	42	62	84

- Two-inch (0 - 3.5 meters) and 1 1/2" inch (3.5 - 5 meters) pistons are used in wells which are not too deep or when motor pumps are used.
- Deep wells (37 - 50 meters) use 1/2" inch pistons with Rim # 16, a double crank system, and wooden bearings. These pumps are installed as on drilled wells in order to increase the contact between the pulley wheel and the rope.



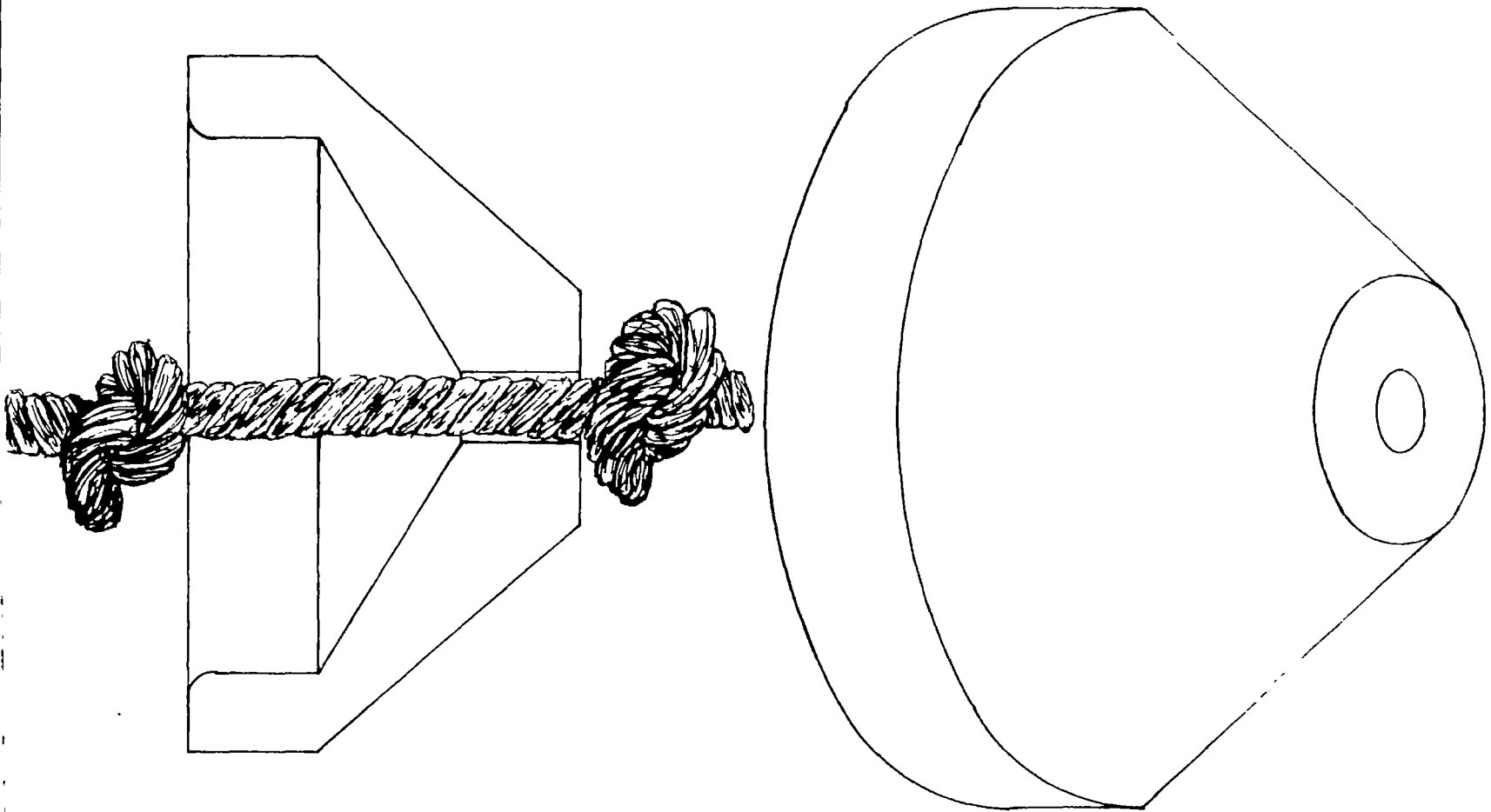



A-02

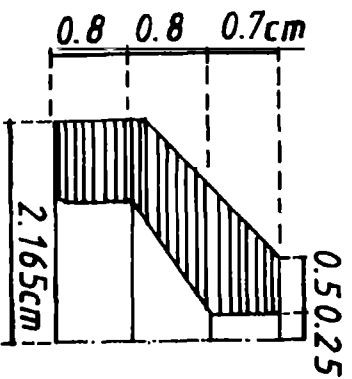
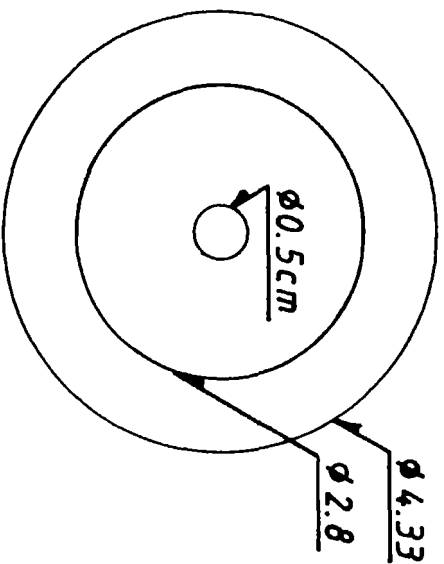
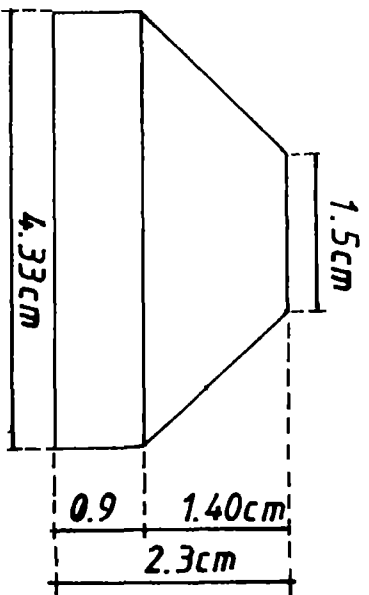
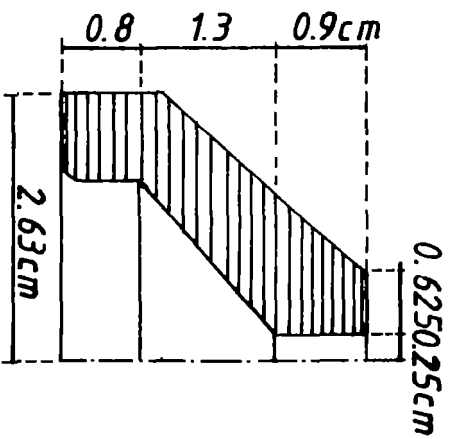
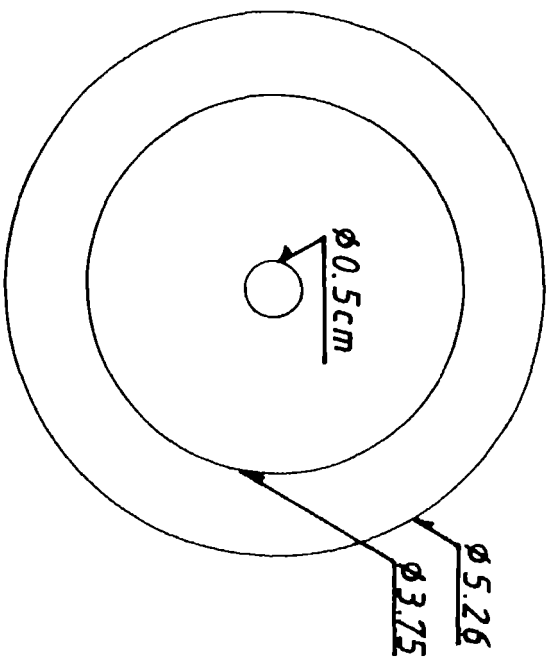
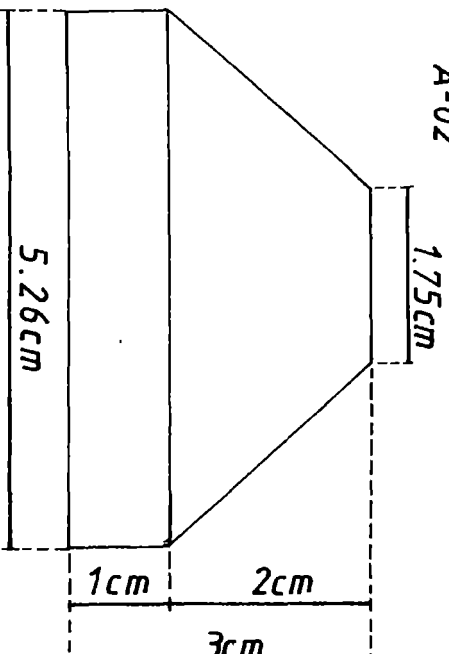



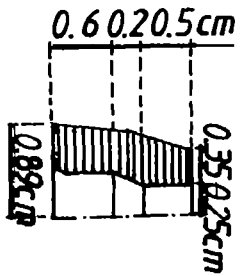
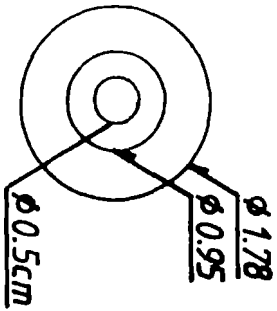
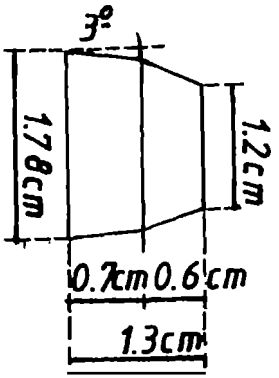
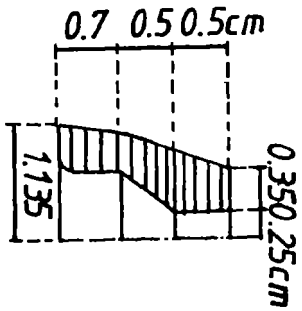
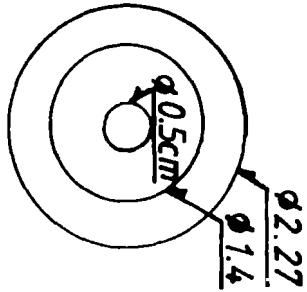
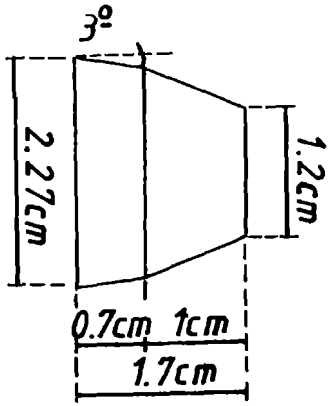
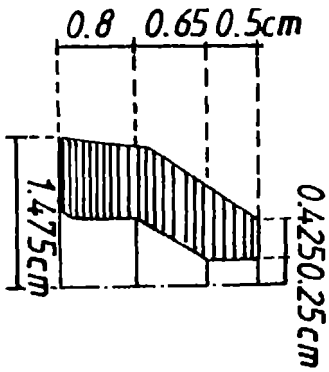
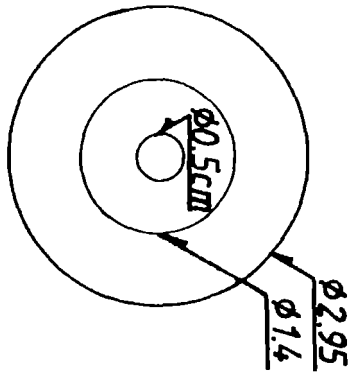
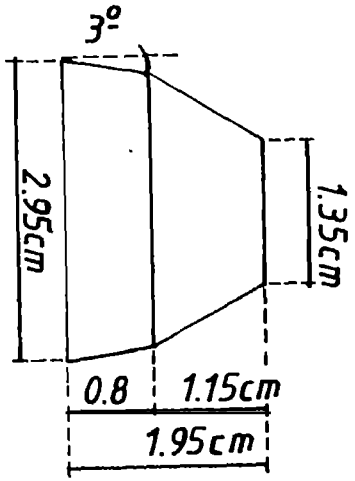



B.1. GUIDE BOX INTERNAL PIECE

- The guide box internal piece is made up of five components:
- The entrance pipe, pumping pipe and protector are made of PVC pipe. Diameter is determined by well depth.
- The ceramic piece and the base part do not vary regardless of well depth.

Measurement variations for the guide box internal piece

Drawing No	Component	Unit	Depth (meters)		
			0 -11	11 - 19	19 - 50
2	Ceramic piece	-	-	-	-
3	Base diameter	Inches	2	2	2
1	Entrance pipe diameter	Inches	1 1/2	1	1
4	Pumping pipe diameter	Inches	1	3/4	1/2
-	Diam. of pumping pipe protector	Inches	1	3/4	1/2

- PVC pipes may vary in diameter depending on the manufacturer. However, it is recommended that they correspond in diameter to the pistons' nominal diameter. This prevents water leaks and increases pumping efficiency.
- The ceramic piece may be replaced by an electric insulator or a bottle, provided that the rope does not wear away.



B₁-01

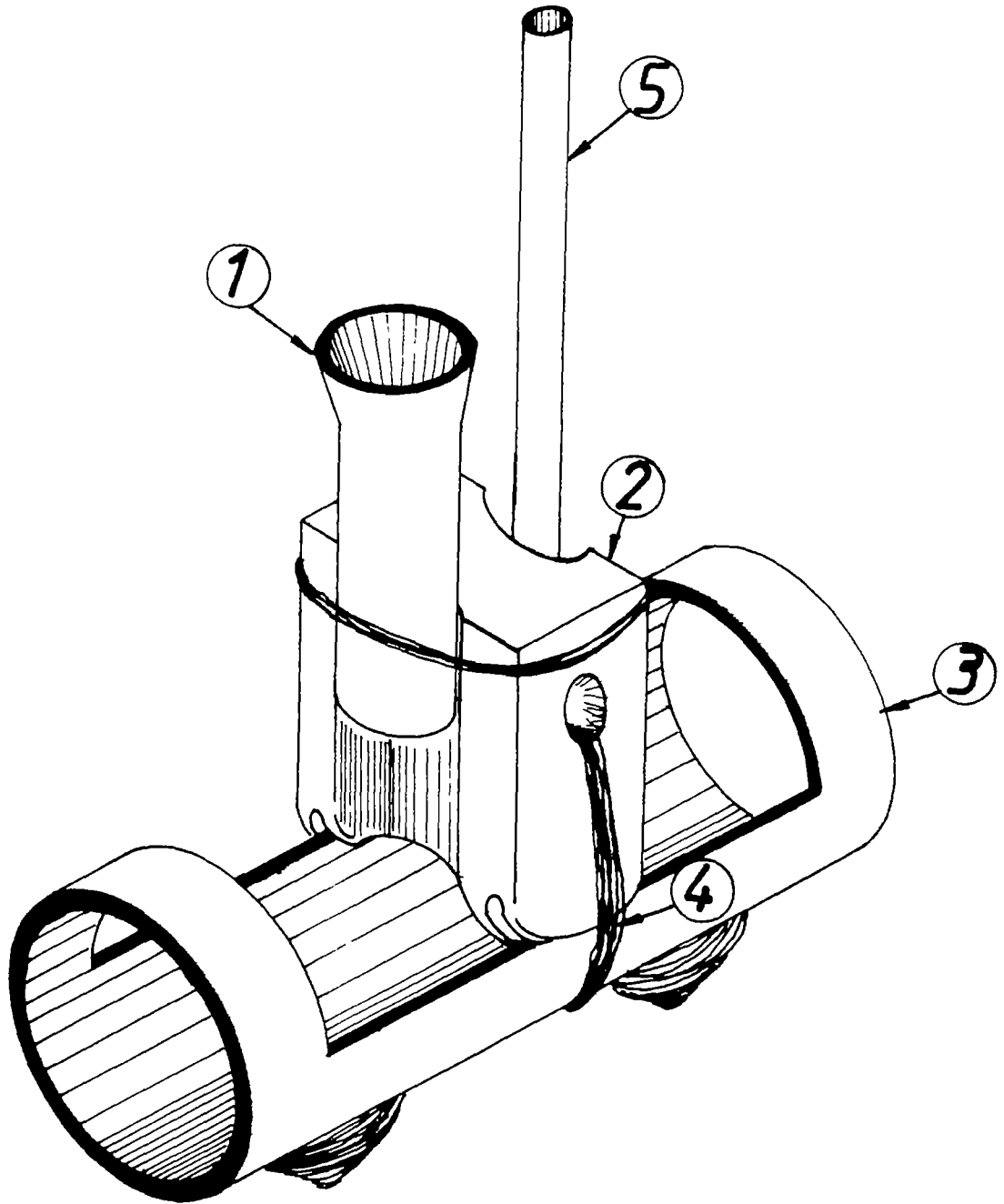



B₁-02

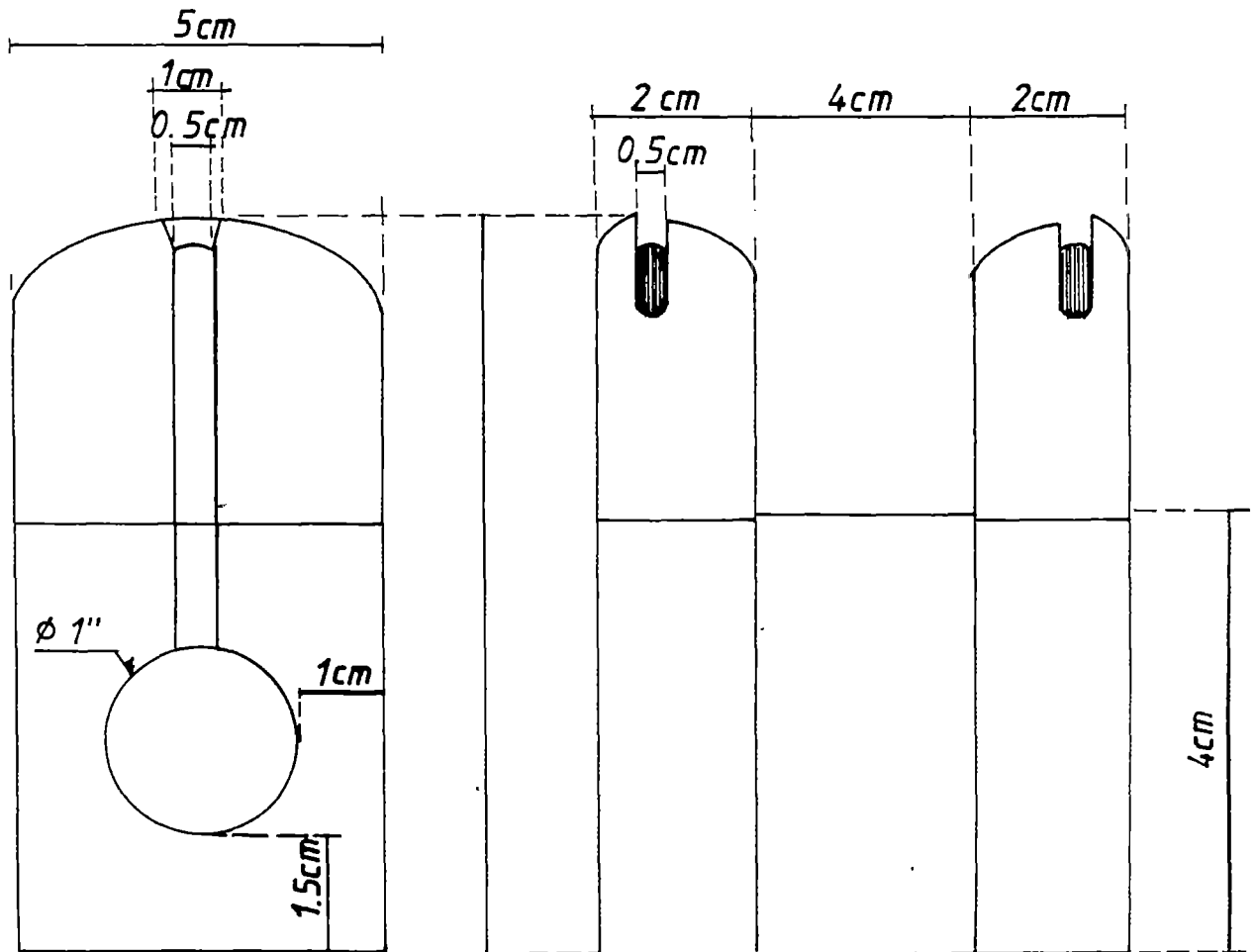
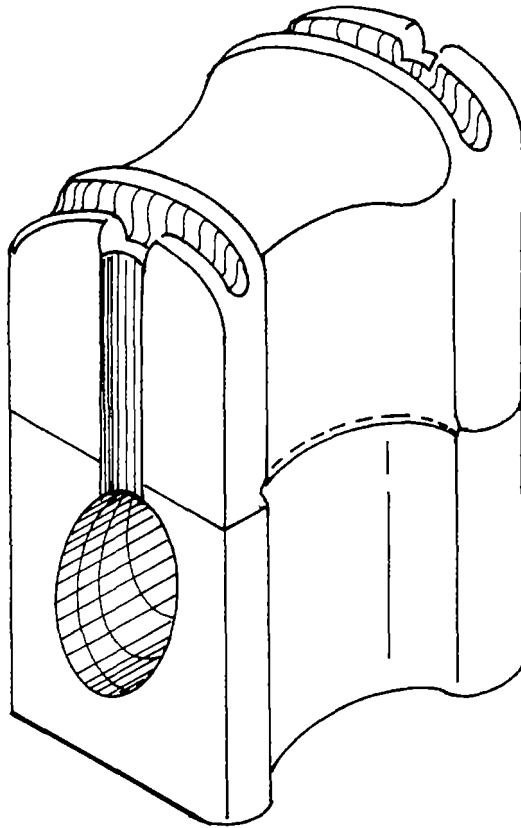



B₁-03

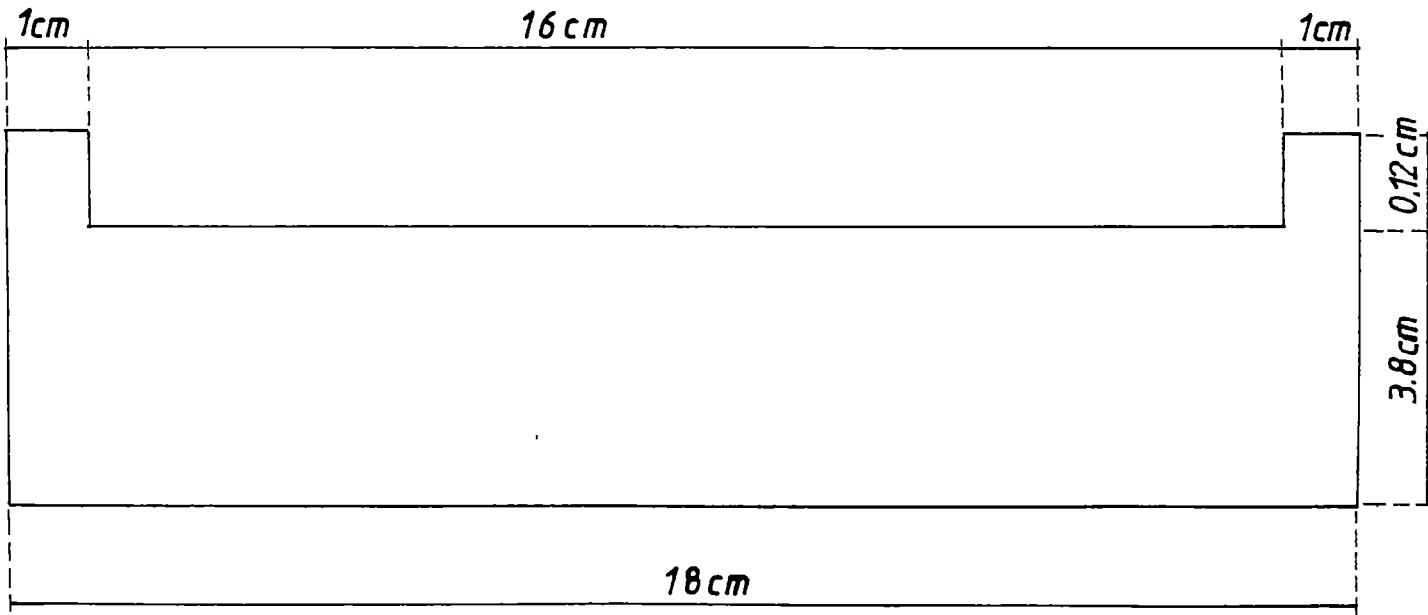
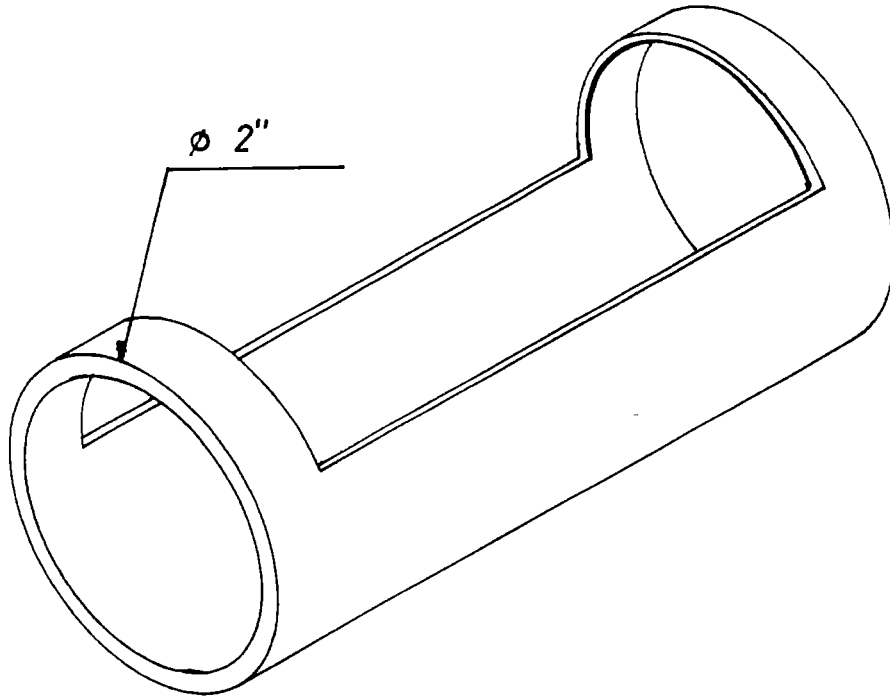



B₁-04

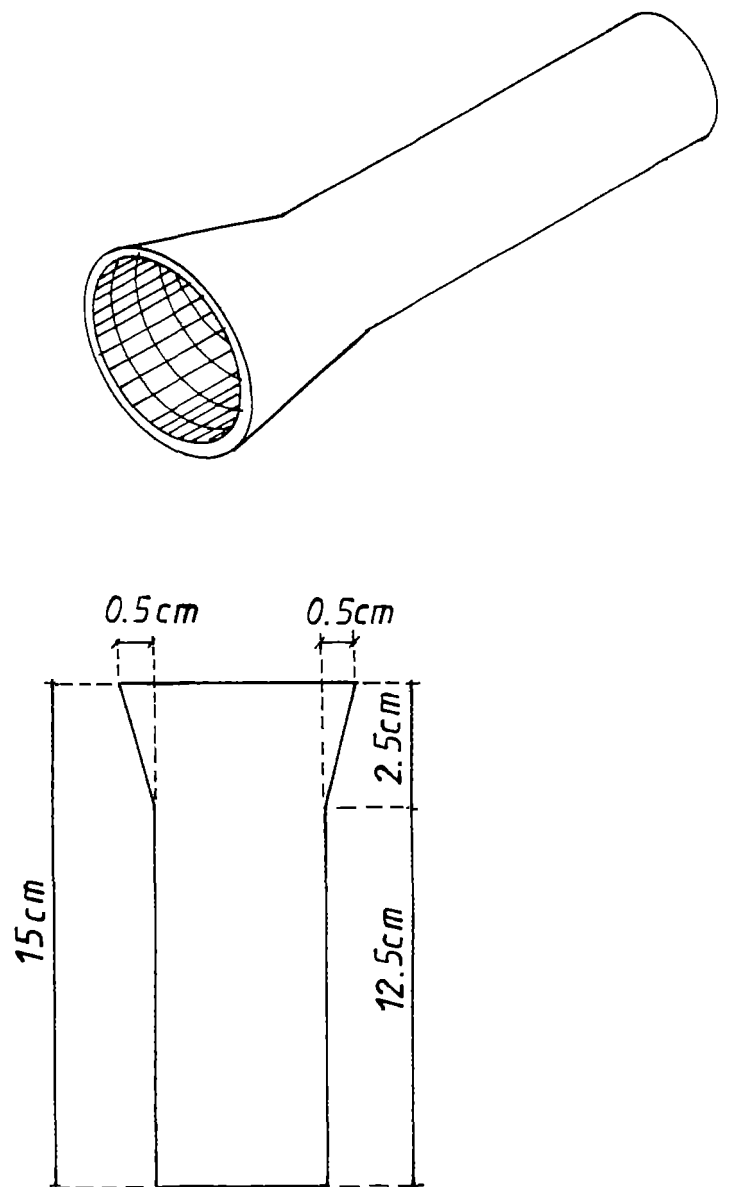
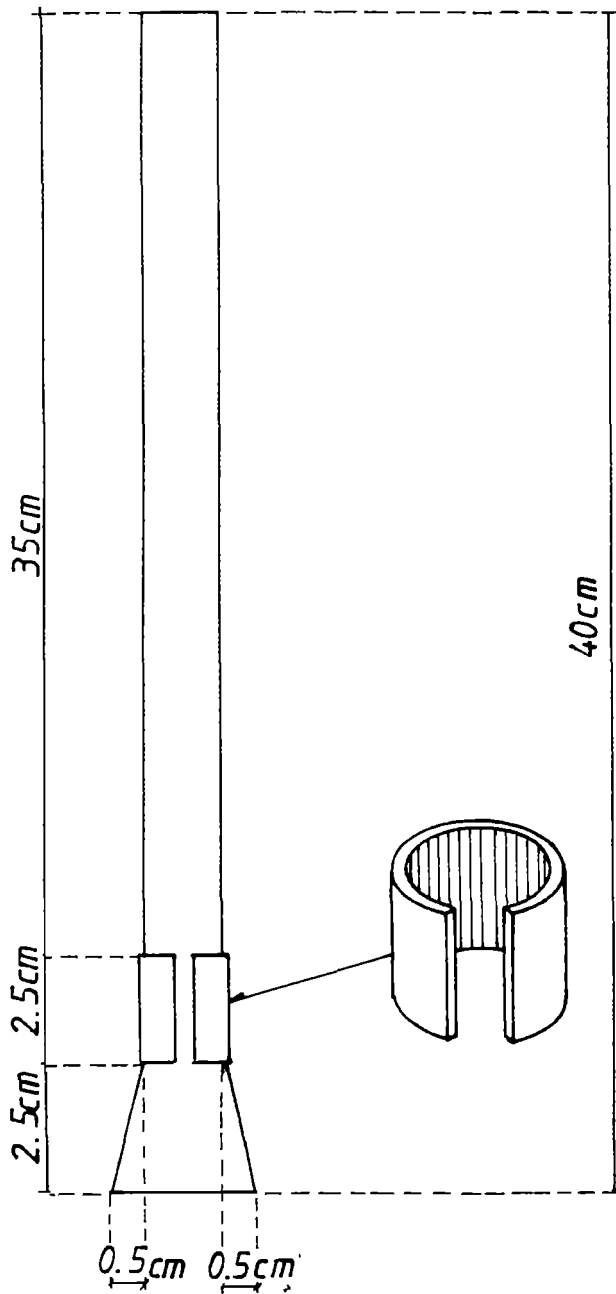



B.2. THE GUIDE

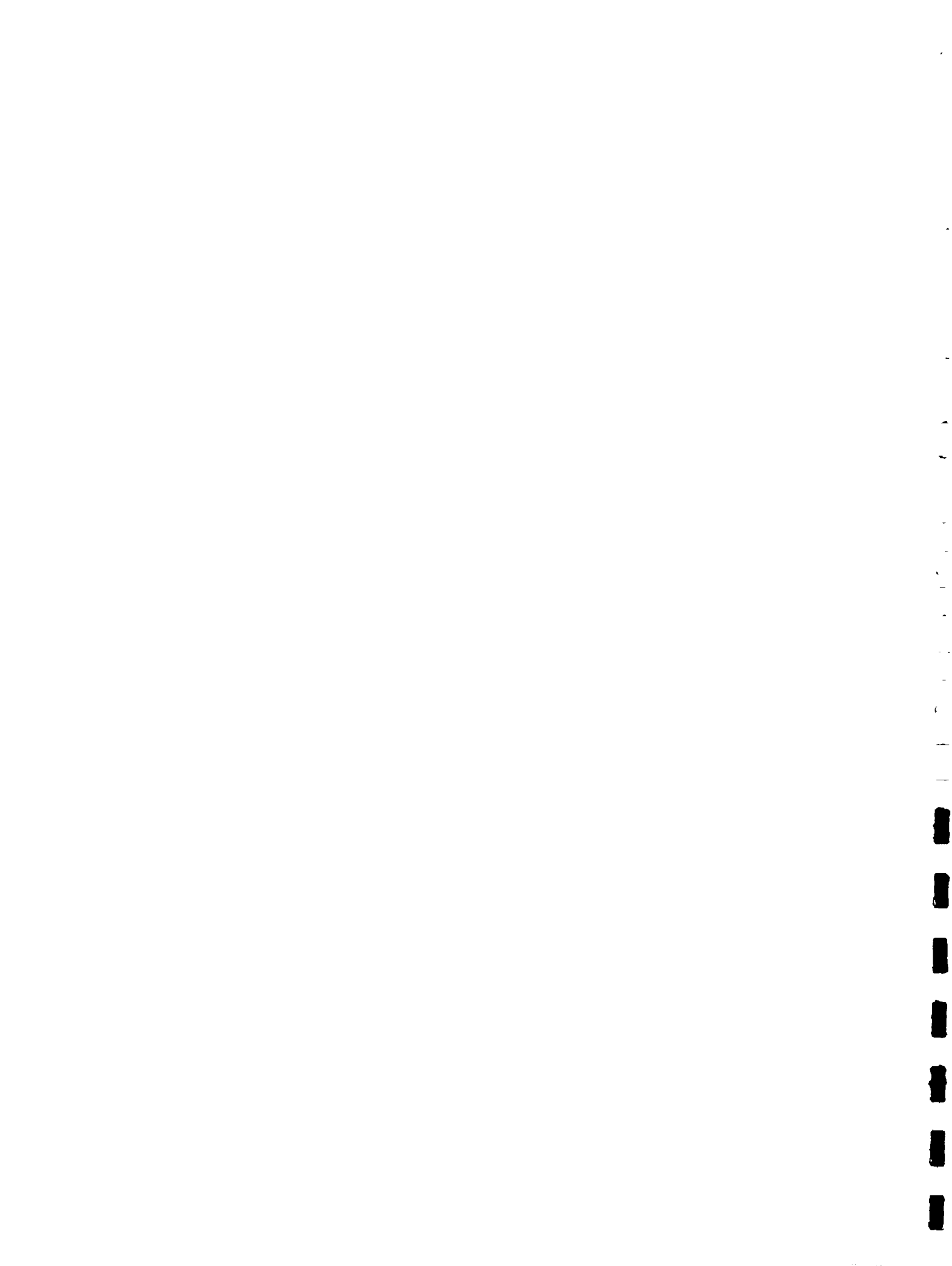

B₂-01

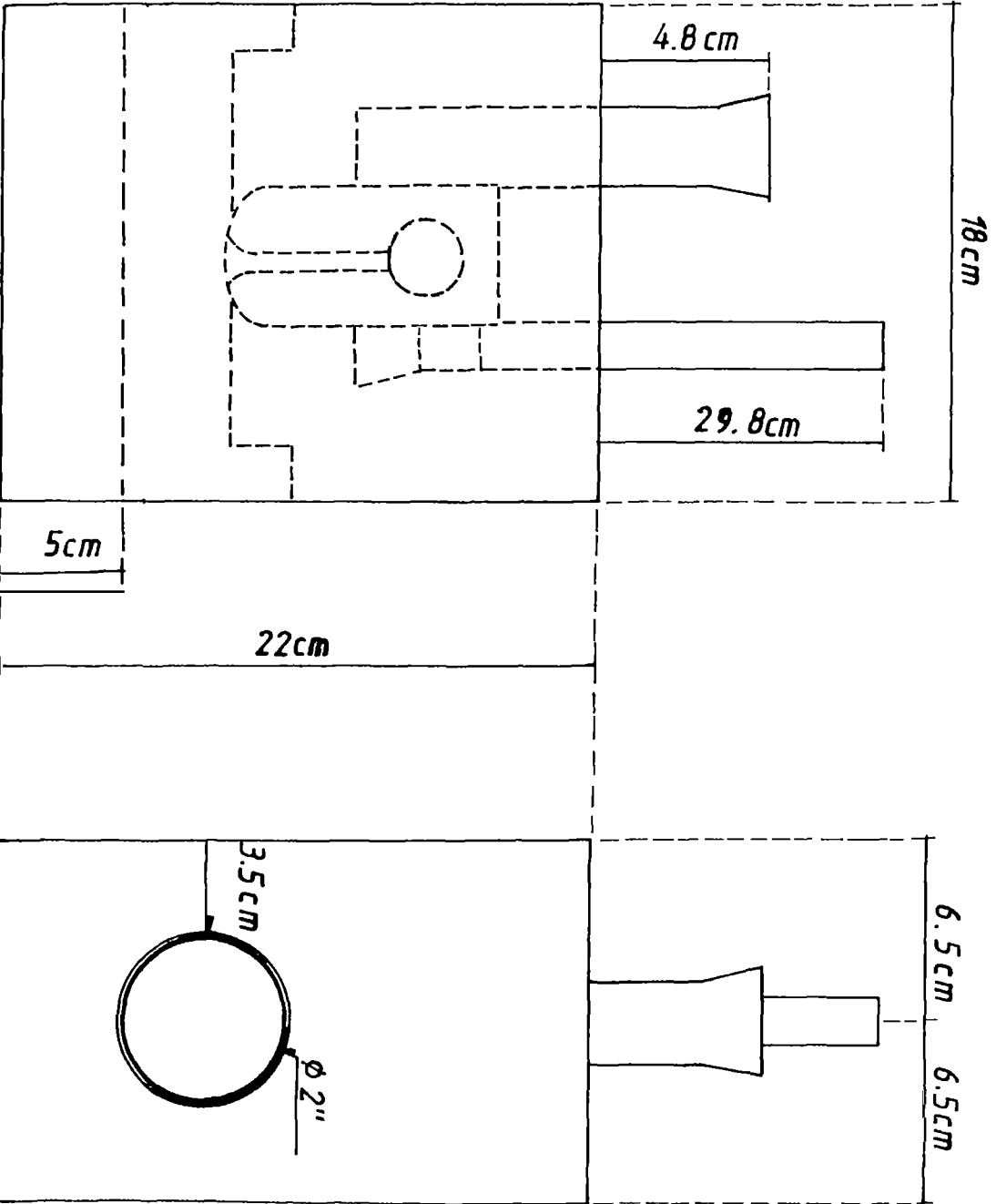
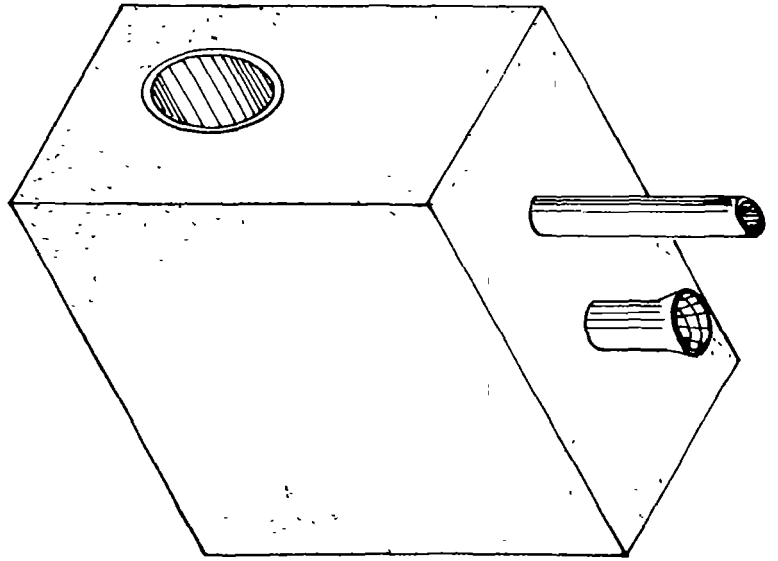



C. EXTRA STRONG ROPE PUMP STRUCTURE

- For community wells serving 3 to 10 families
- For school wells
- For water and sanitation projects
- For family gardens
- Its structure is strong.
- It generally has a wheel protection cover.

C - GENERAL - 01

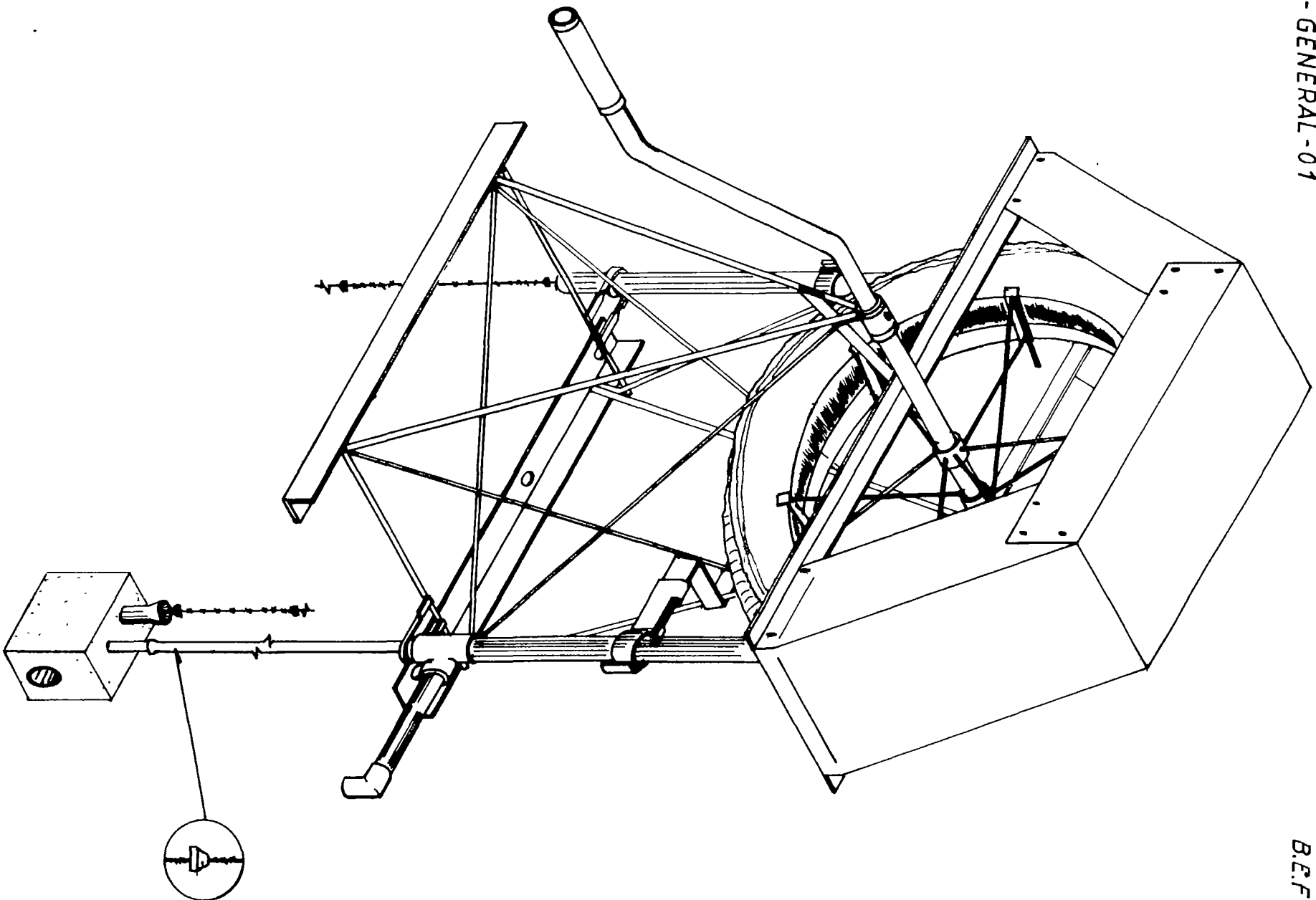

B.E.F



C-GENERAL-02

B.E.E.

80cm

41cm

102cm

37cm

65cm

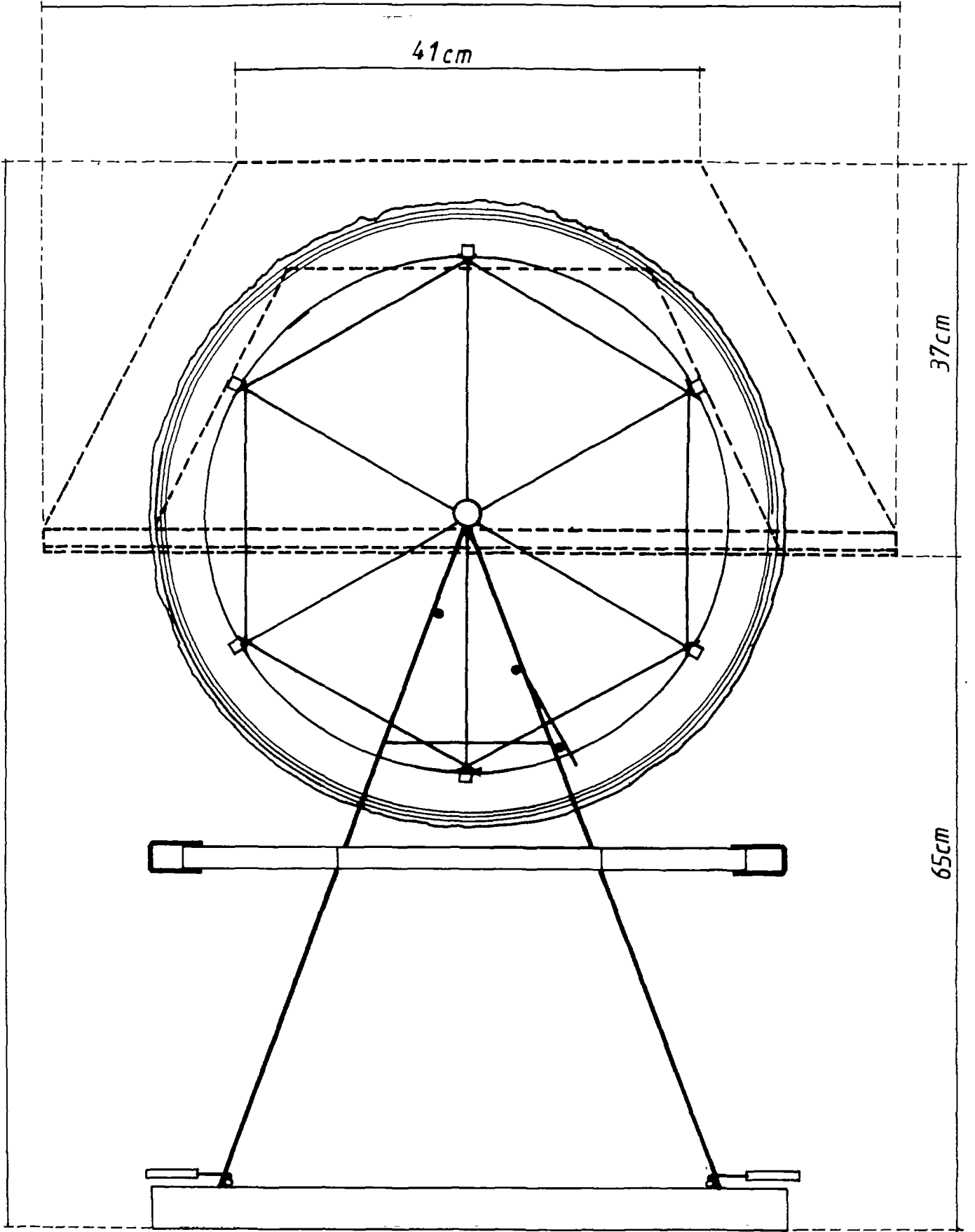



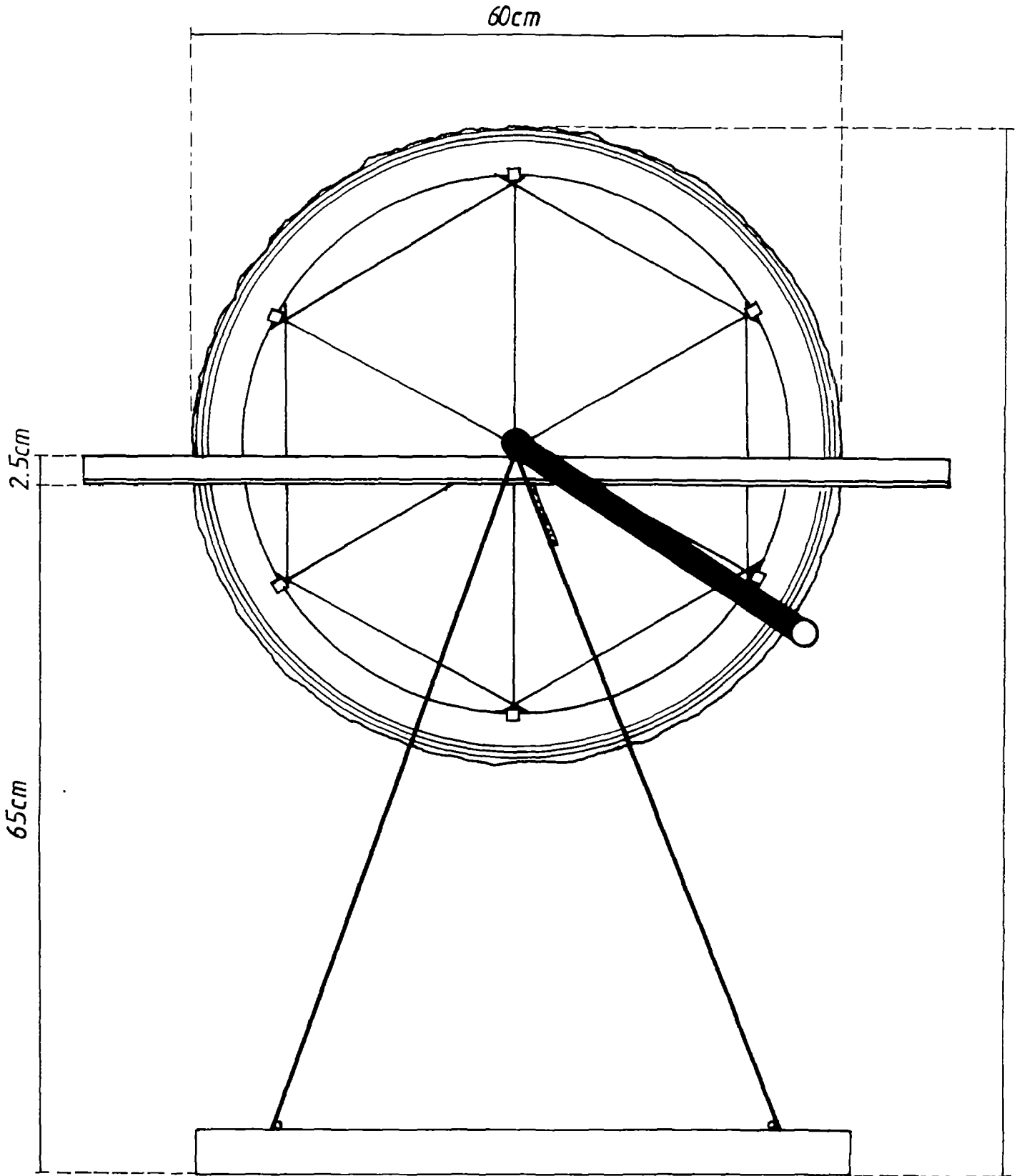



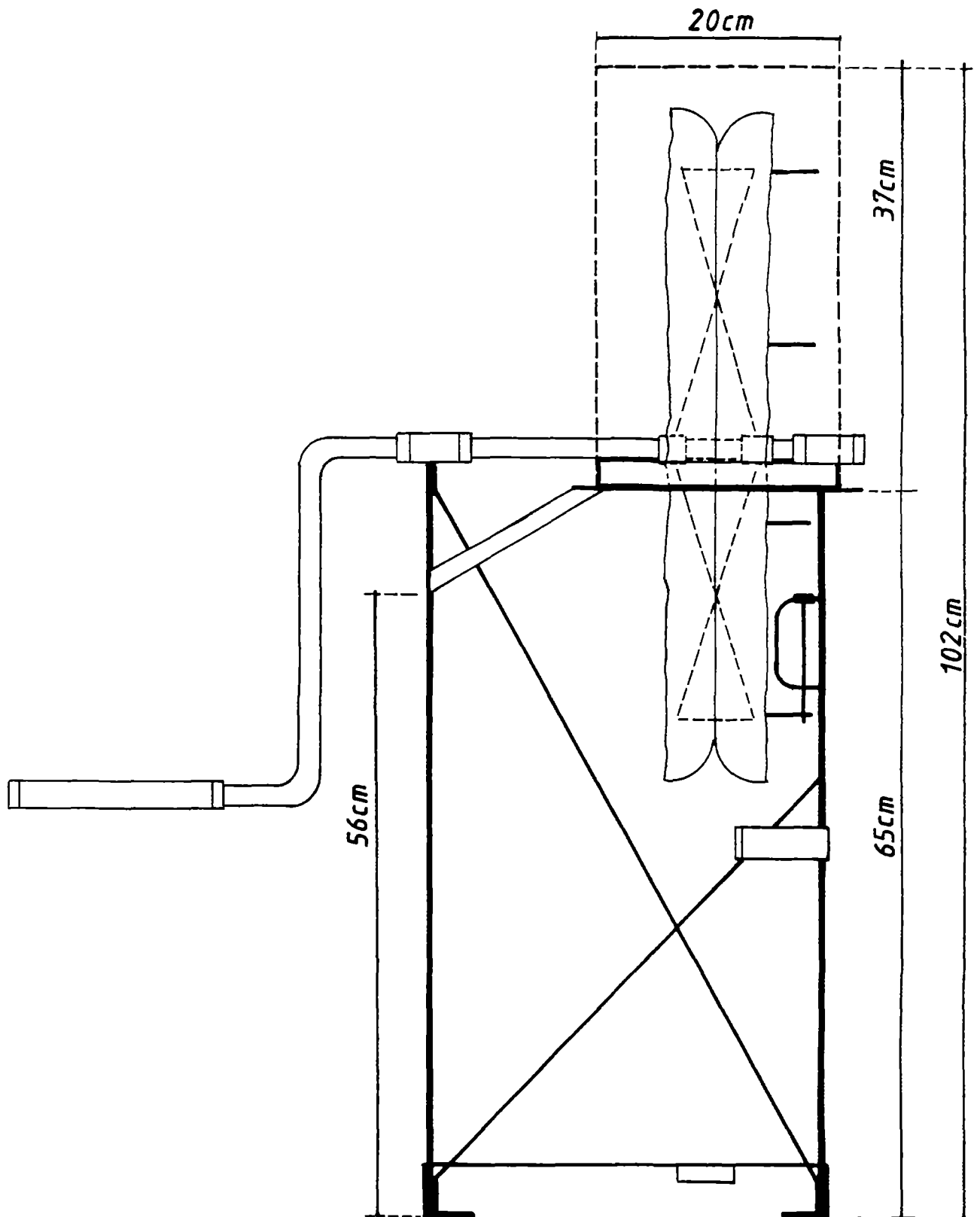



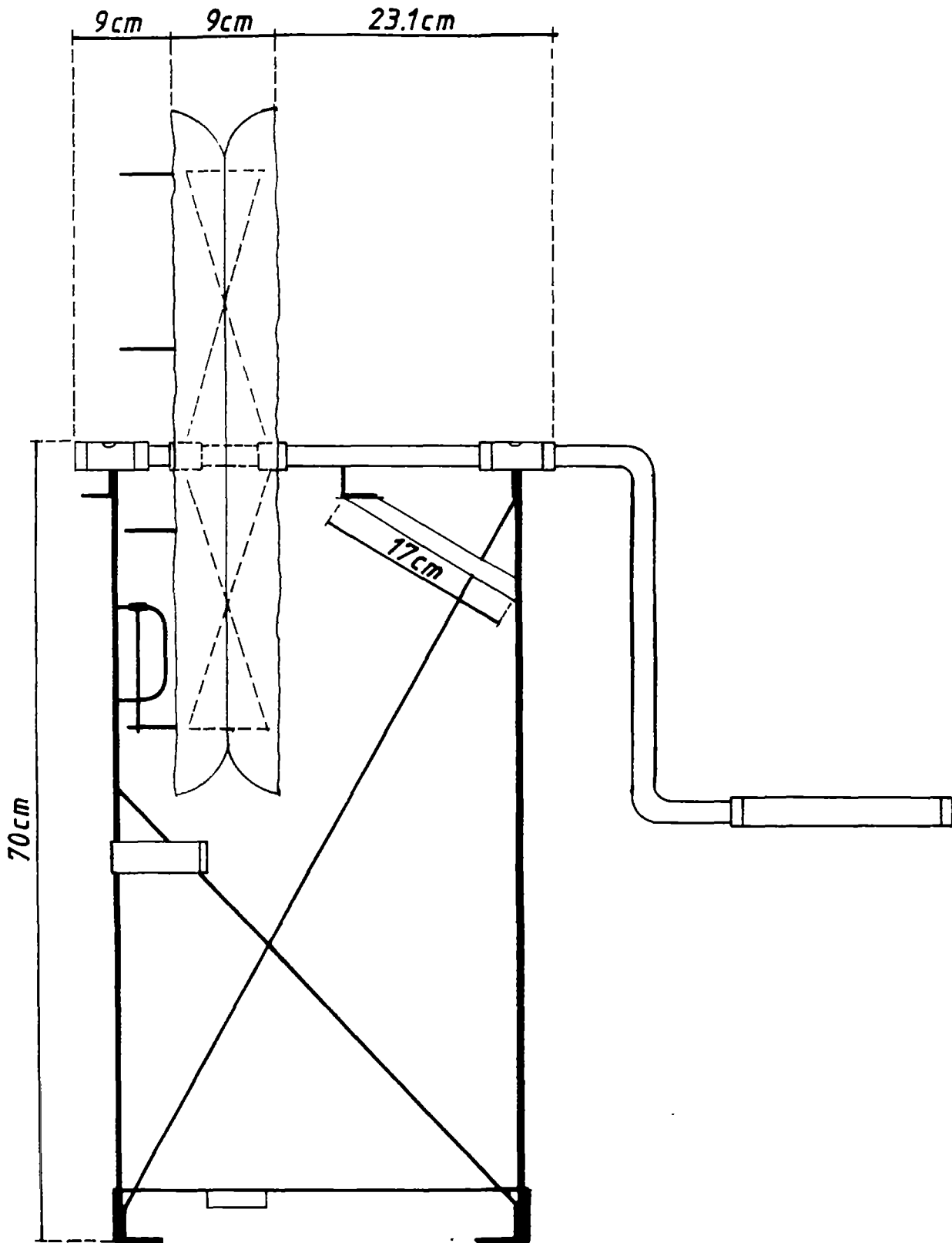



C.a. THE CRANK

MATERIALS FOR CRANK PRODUCTION

Amount	Materials	Measures	Section
1	Black pipe	3/4" x 100 cm.	Shaft
1	Galvanized pipe	1" x 15 cm	Roller
2	Galvanized pipes	1" x 1 cm	Spacers

- Pumps for 0 - 37 meter deep wells use one crank,
- Pumps for 37 - 50 meter deep wells are specially built with wooden bearings and double crank.



C-a-01

B.E.F

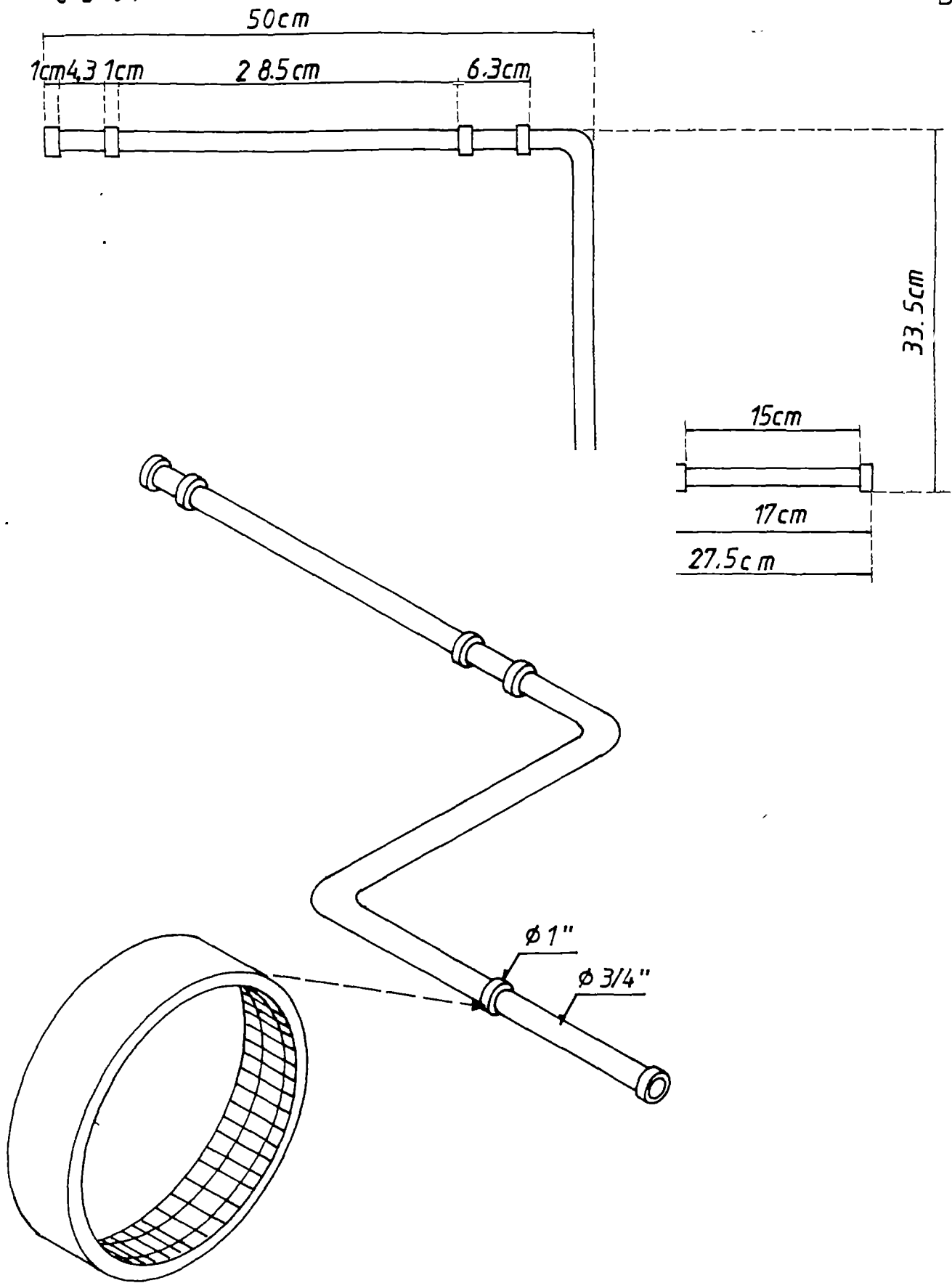



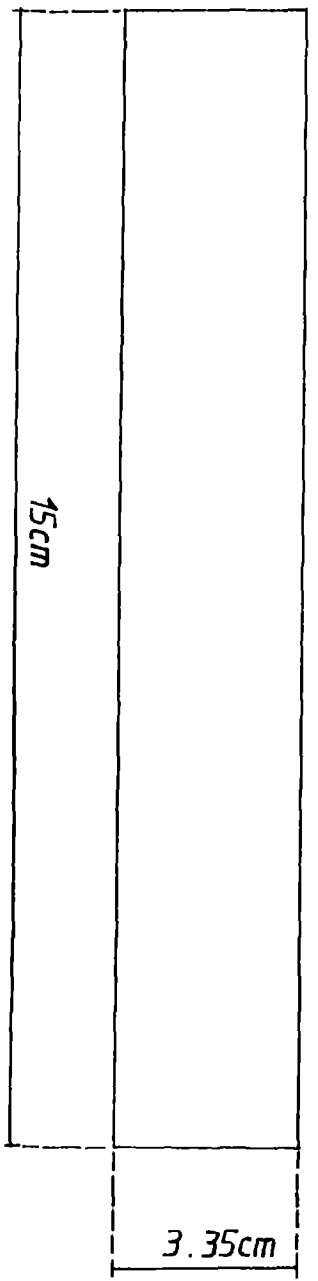
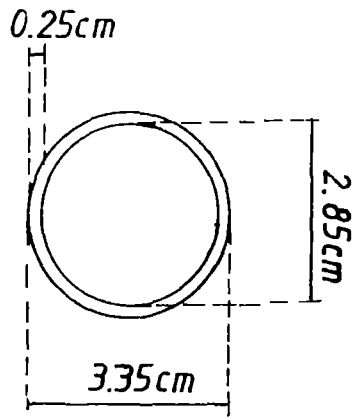
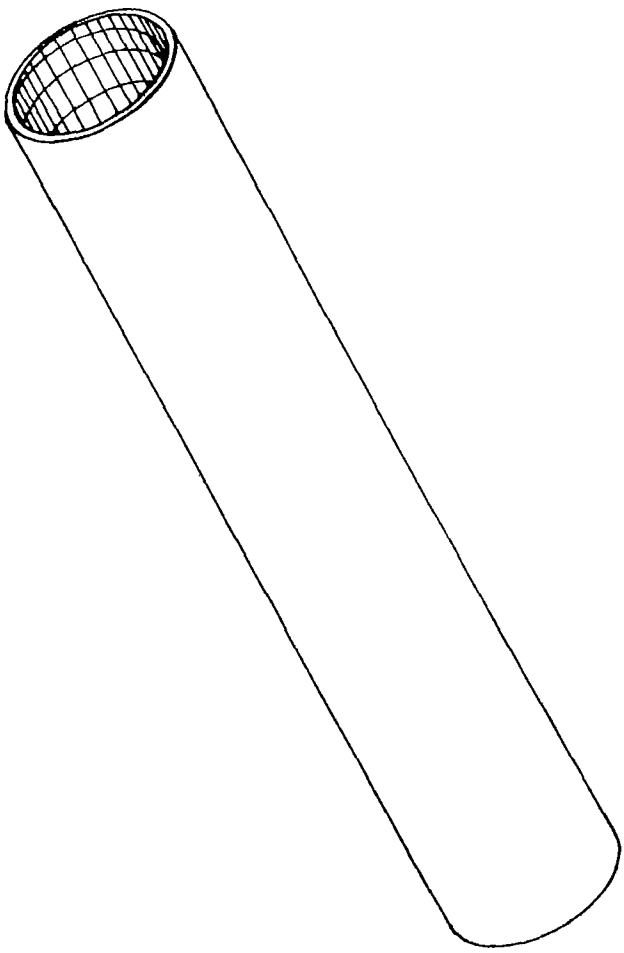



C.b. LEG ASSEMBLY

LIST OF MATERIALS

Amount	Materials	Measures	Section
4	Corrugated rods	1/2" x 70 cm	Leg
1	Corrugated rod	3/8" x 13 cm	Horizontal cross bar
2	Pipes	1" x 4.3cm	Bushings
4	Pipes	1" x 1 cm	Spacers



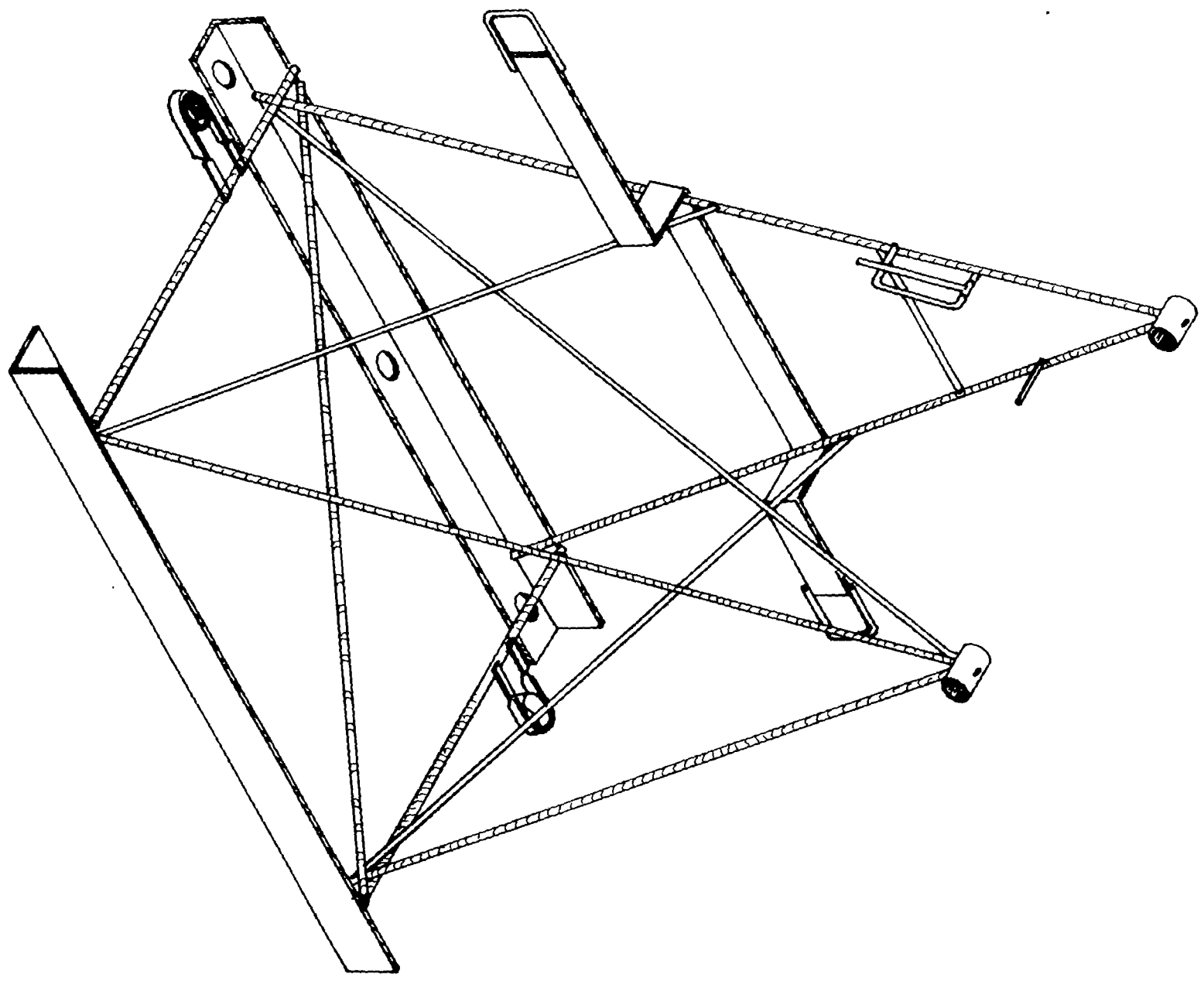

C-B-01

BEF



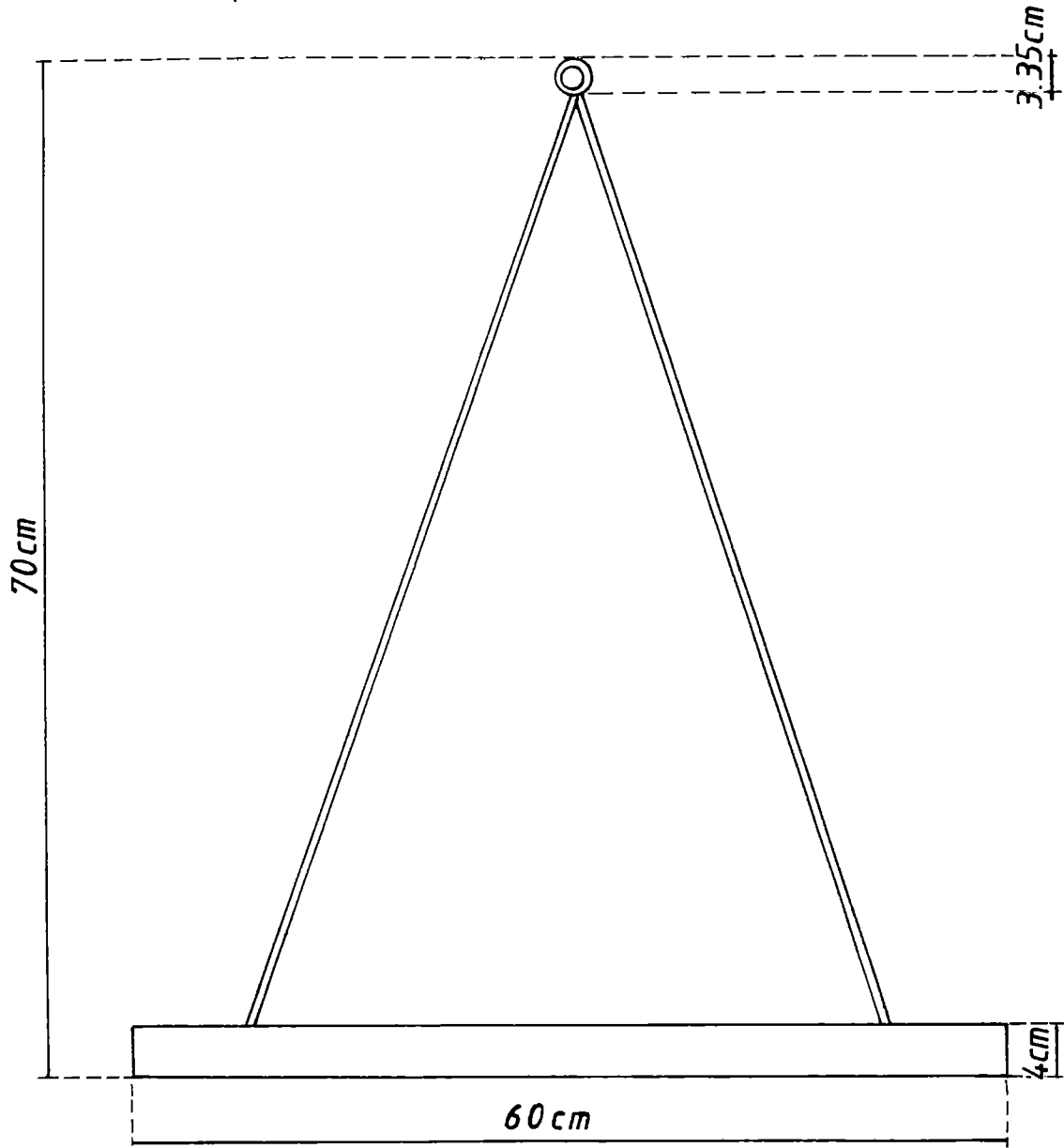



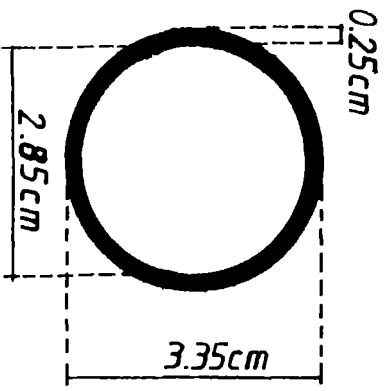
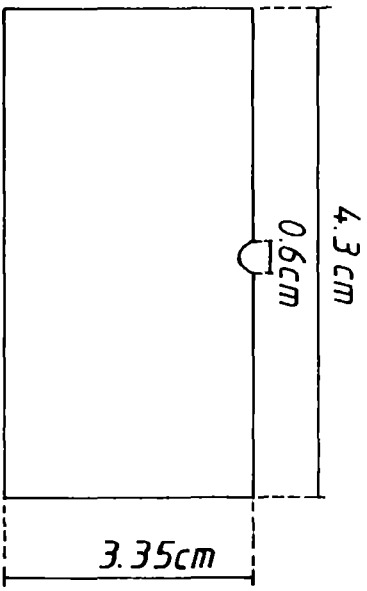
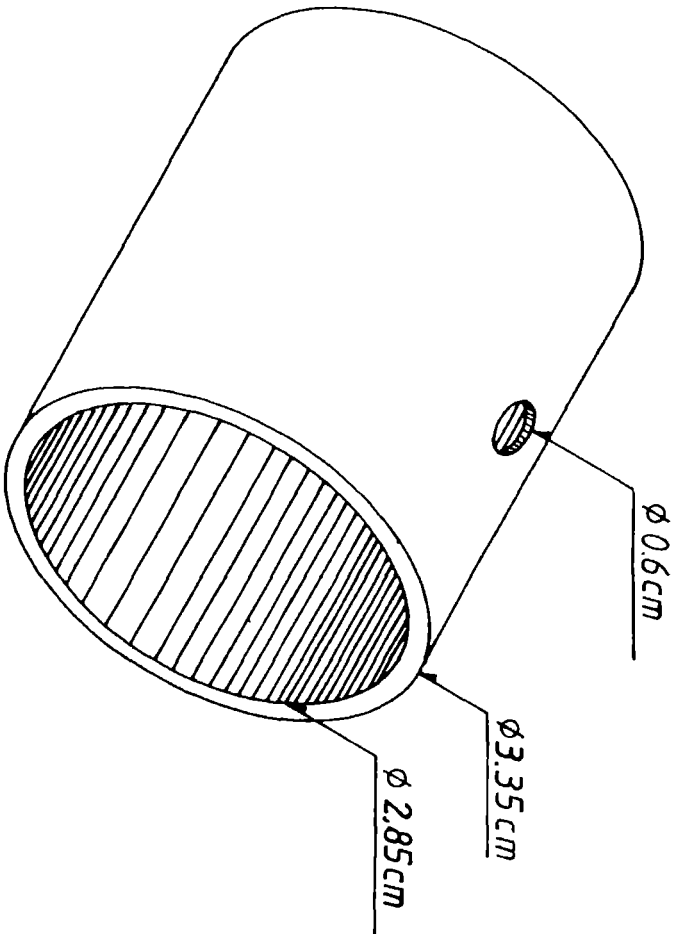



C.c. LEG REINFORCEMENT

LIST OF MATERIALS

Amount	Materials	Measures	Section
1	Smooth rod	1/4" x 77 cm	Cross bar
1	Smooth rod	3/8" x 77 cm	Cross bar
2	Smooth rods	1/4" x 53 cm	Cross bars



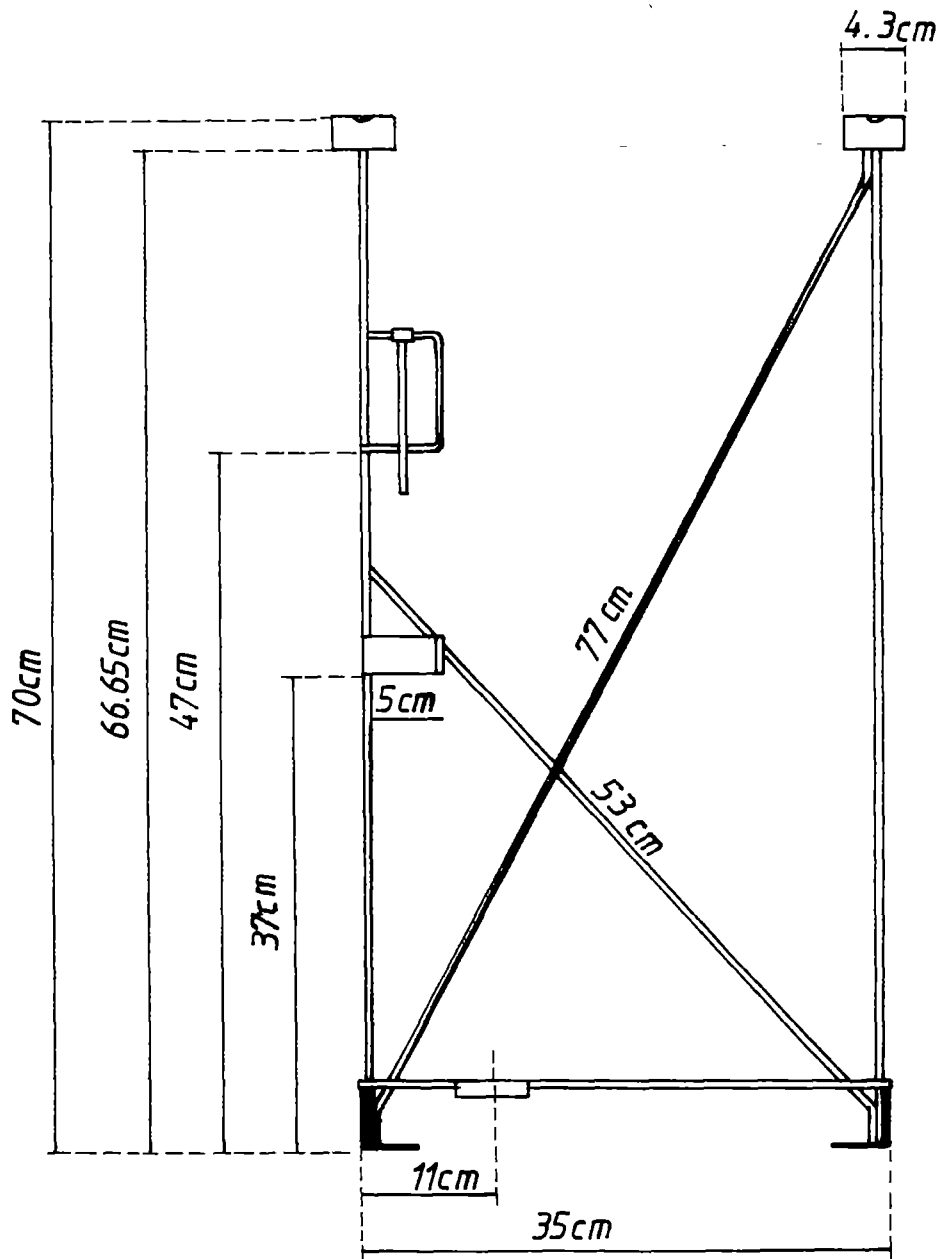

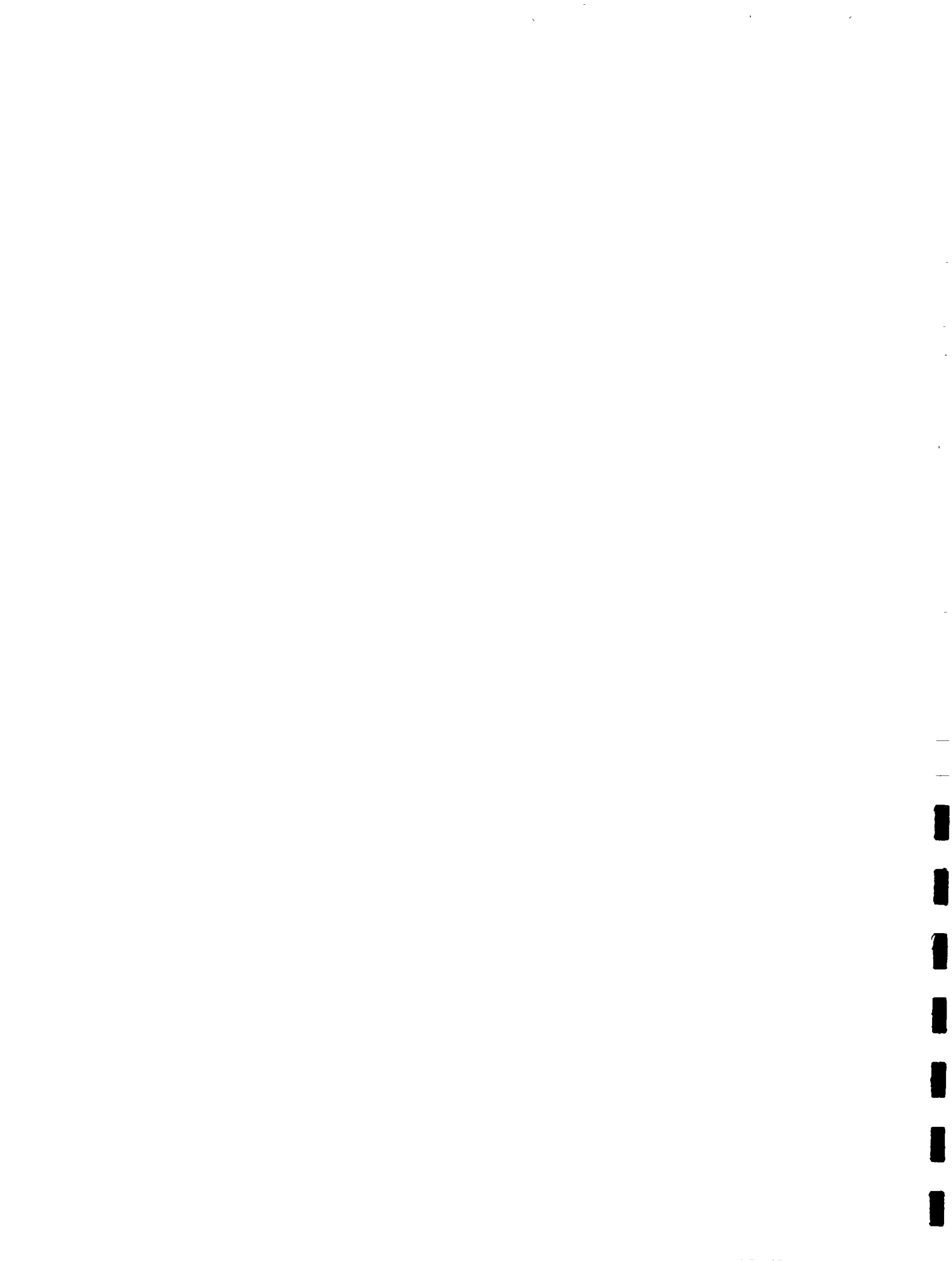

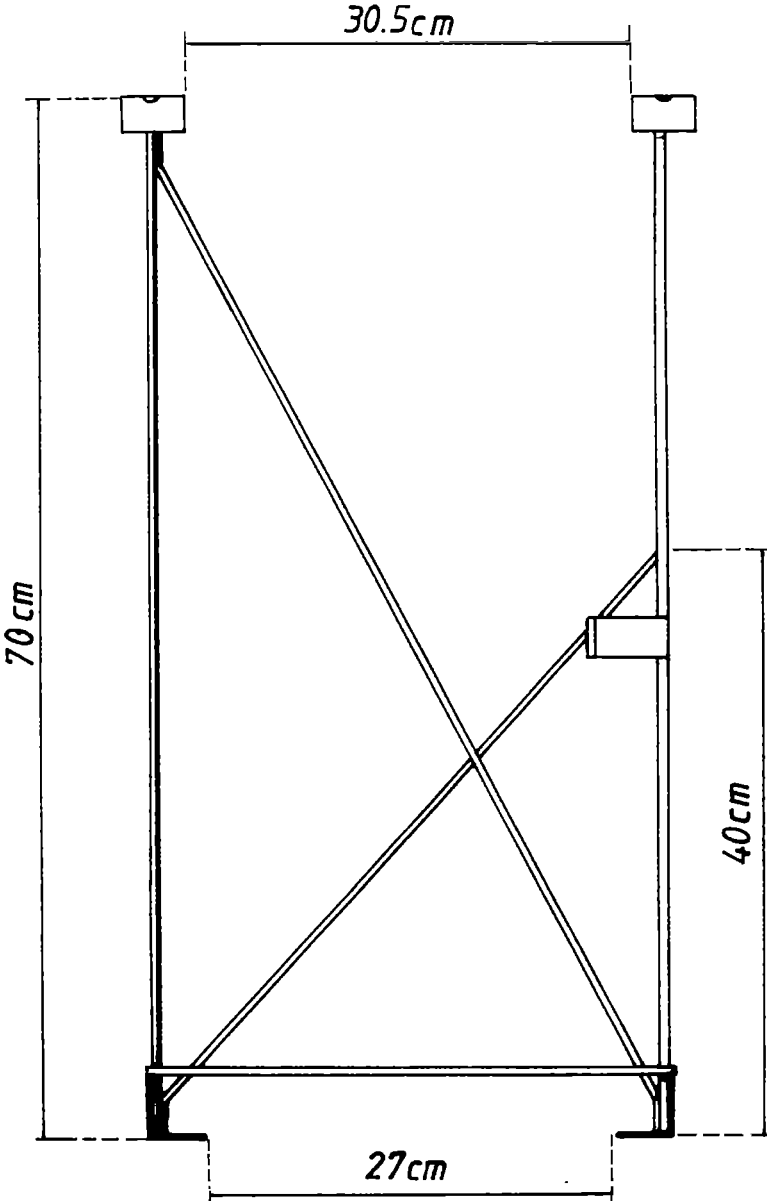



C.d. ANGLE IRONS

LIST OF MATERIALS

Amount	Materials	Measures	Section
2	Angle irons	1/8 x 1 1/2 x 60 cm	Angle irons for base
1	Corrugated rod	1/4" x 54 cm	Reinforcement bar
2	Corrugated rods	3/8" x 34 cm.	Reinforcement bars

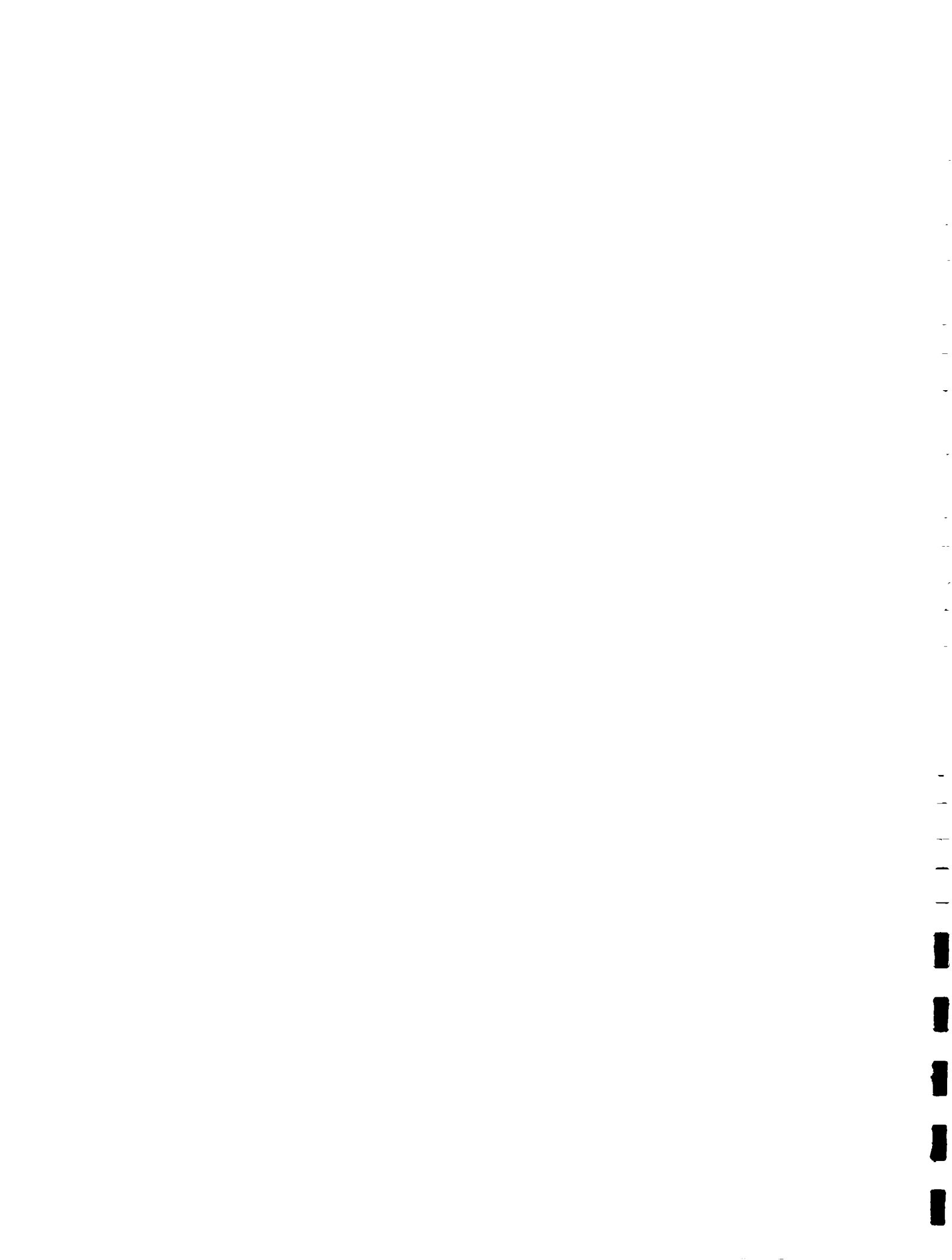

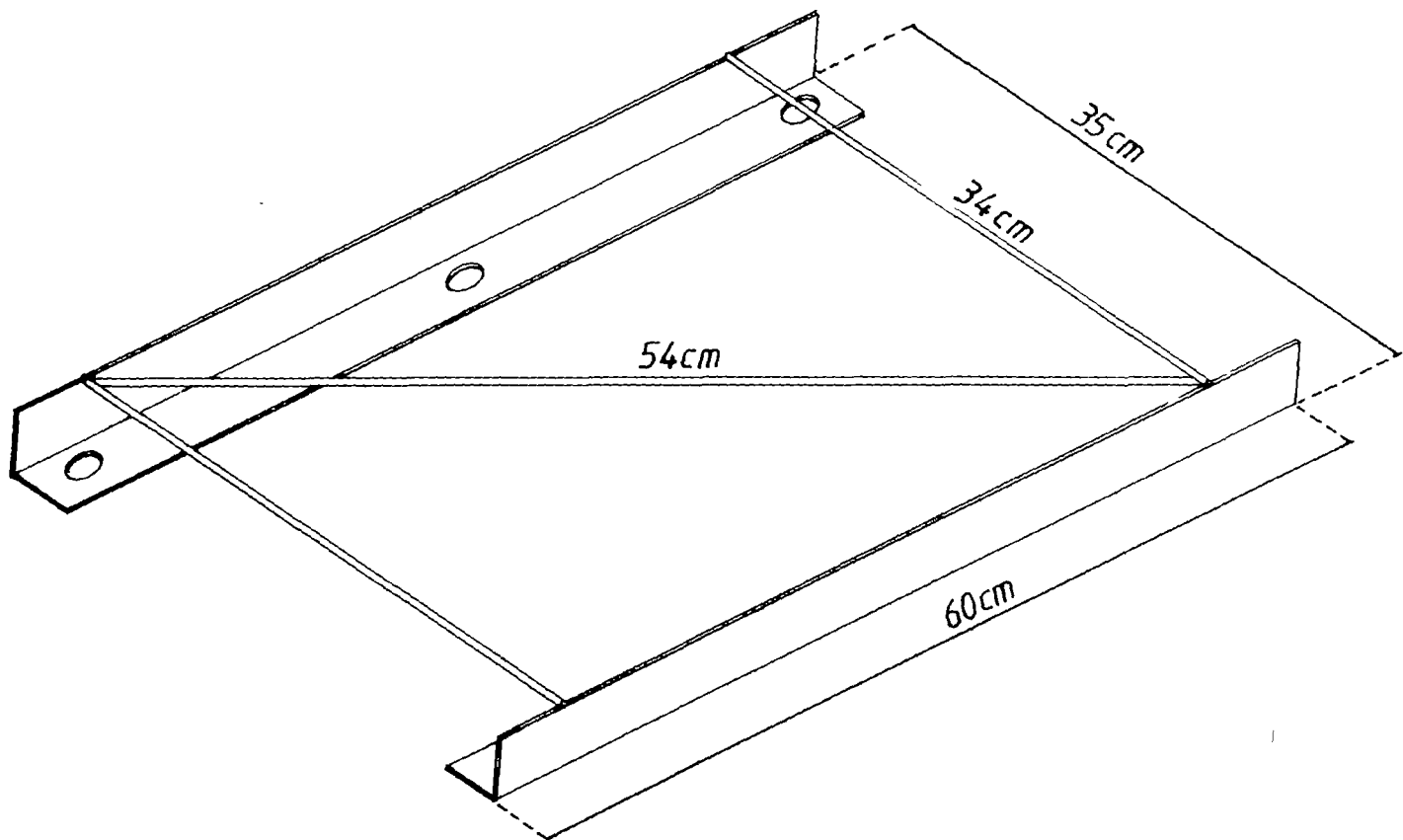

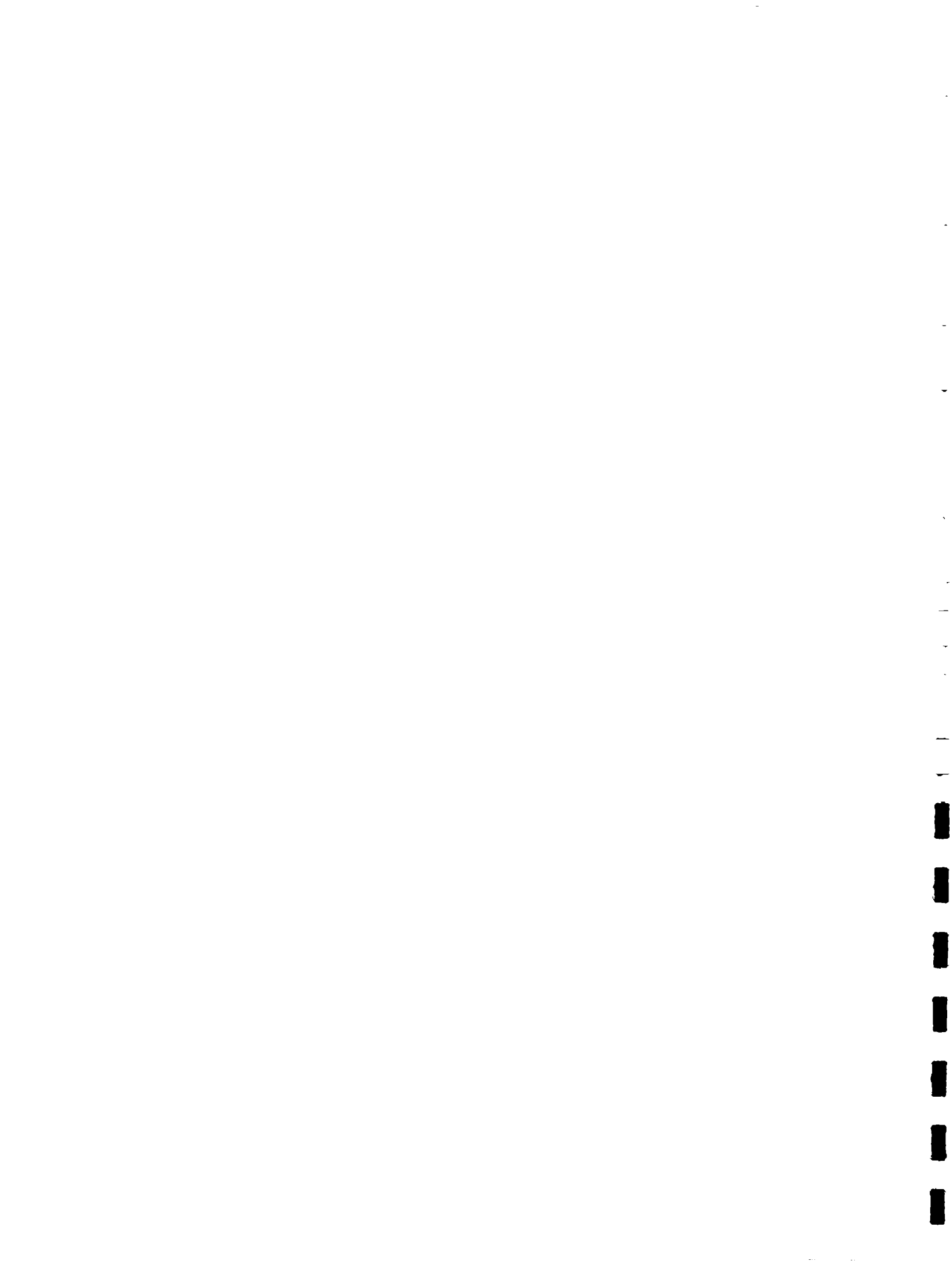

C.e. THE PULLEY WHEEL HUB

LIST OF MATERIALS

Amount	Materials	Measures	Section
12	Smooth rods	1/4" x 25 cm	Spokes
6	Smooth rods	1/4" x 25 cm	Reinforcement bars
6	Steel strips	1/8" x 1"x 10 cm	Staples
2	Pipes	1" x 2.5 cm	Bushings
2	Tire cuttings	rim# 20"	Wheel

- Tire cuttings rim # 16 are used for 29 to 50 meter deep wells with wooden bearings and a double crank system which should be installed as on drilled wells.



C-2-01

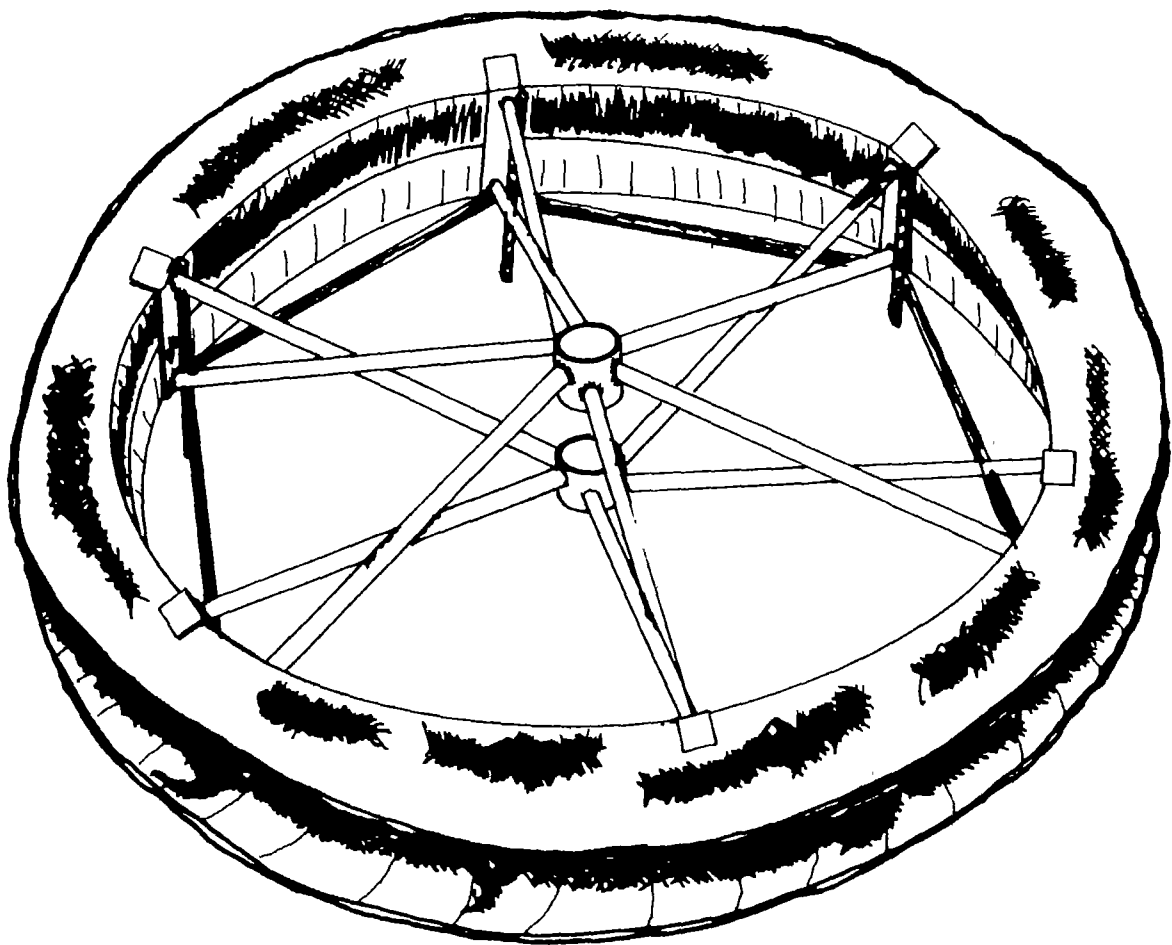

B.E.F



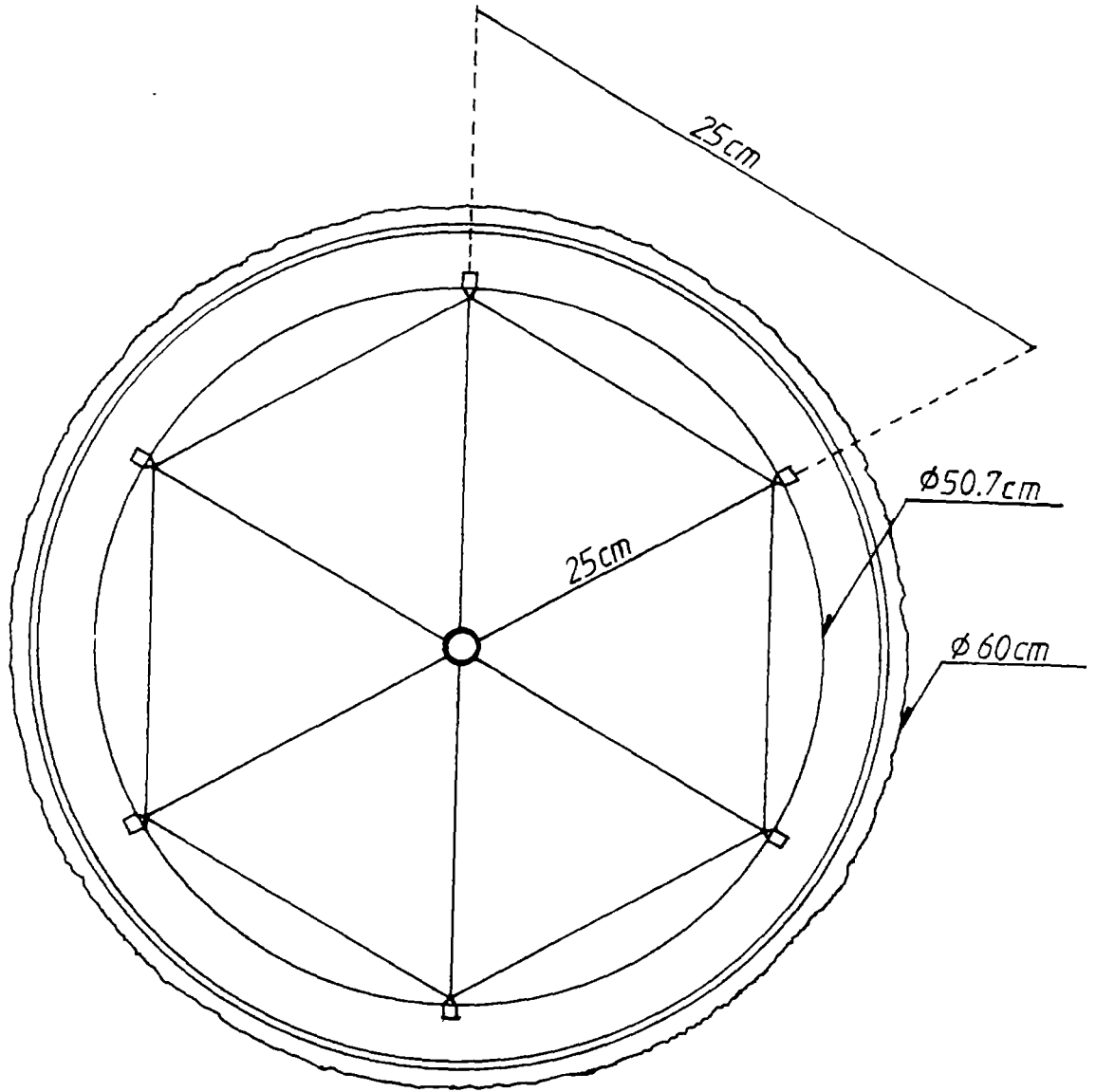



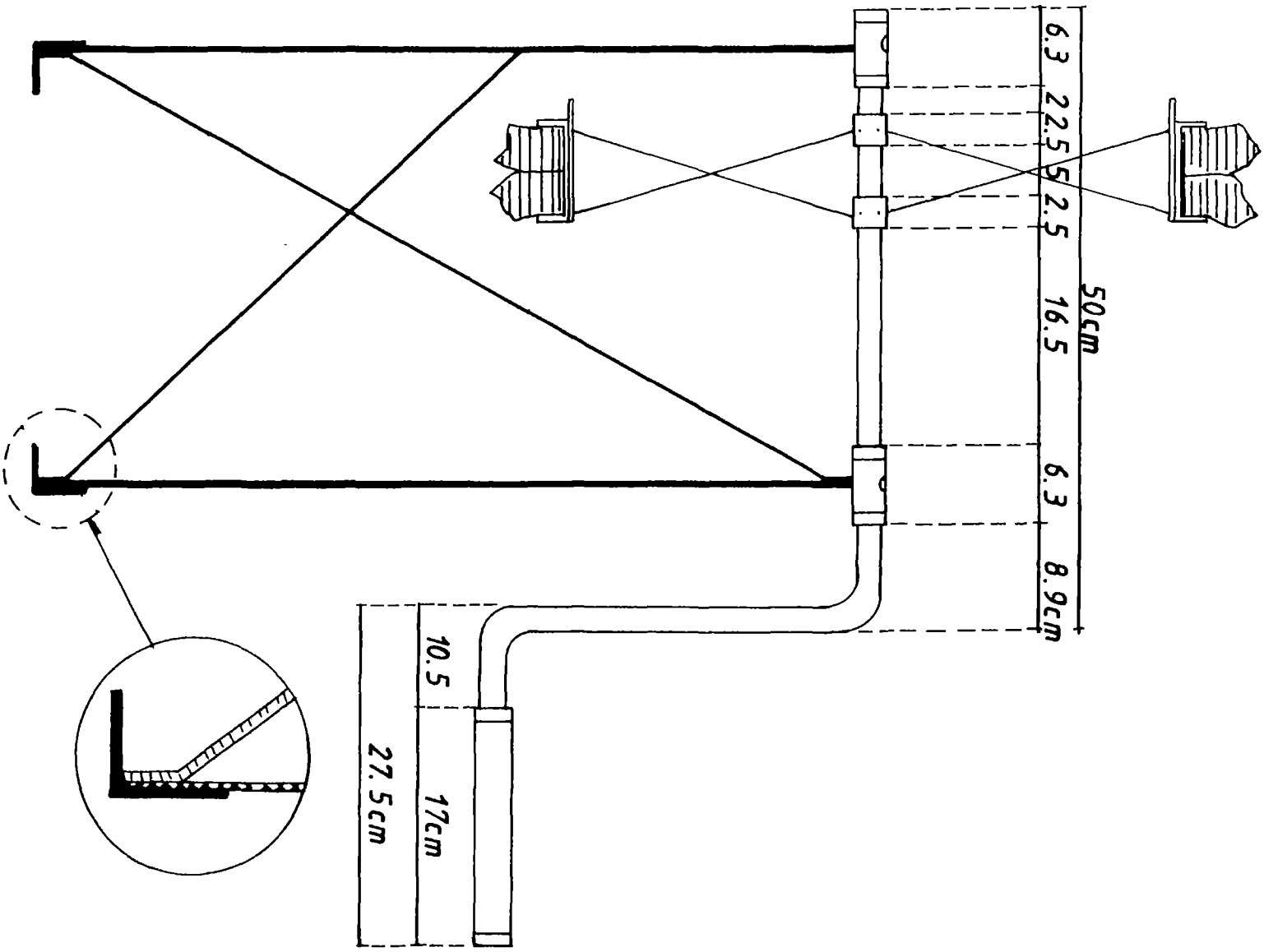



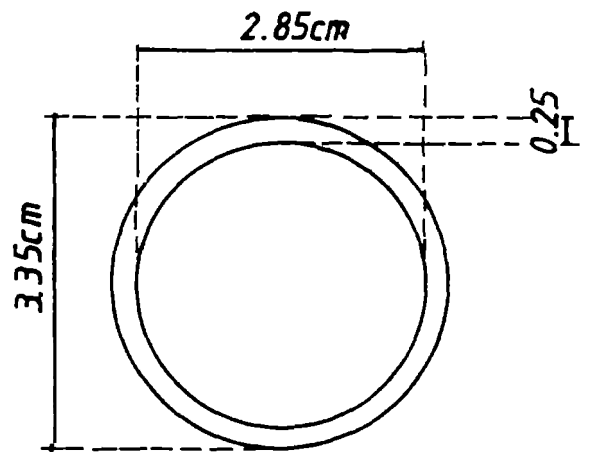
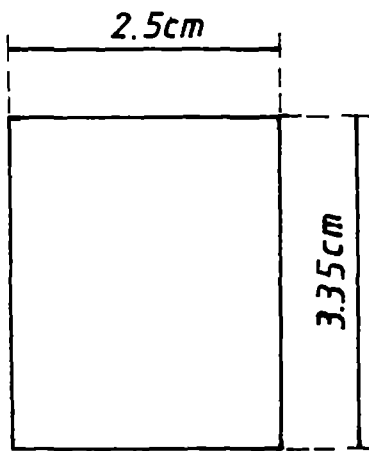
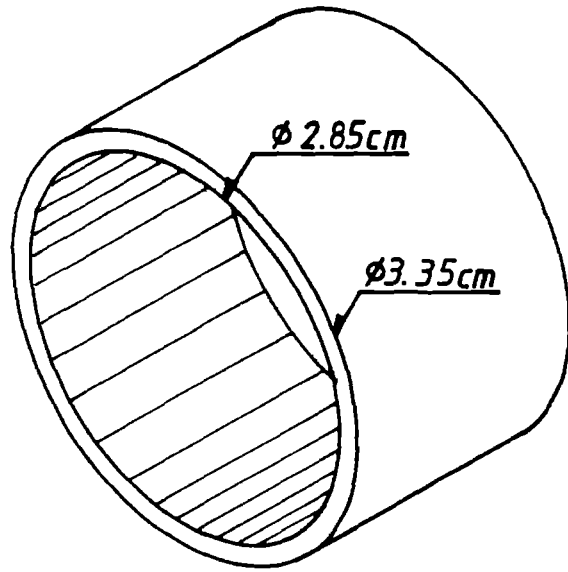



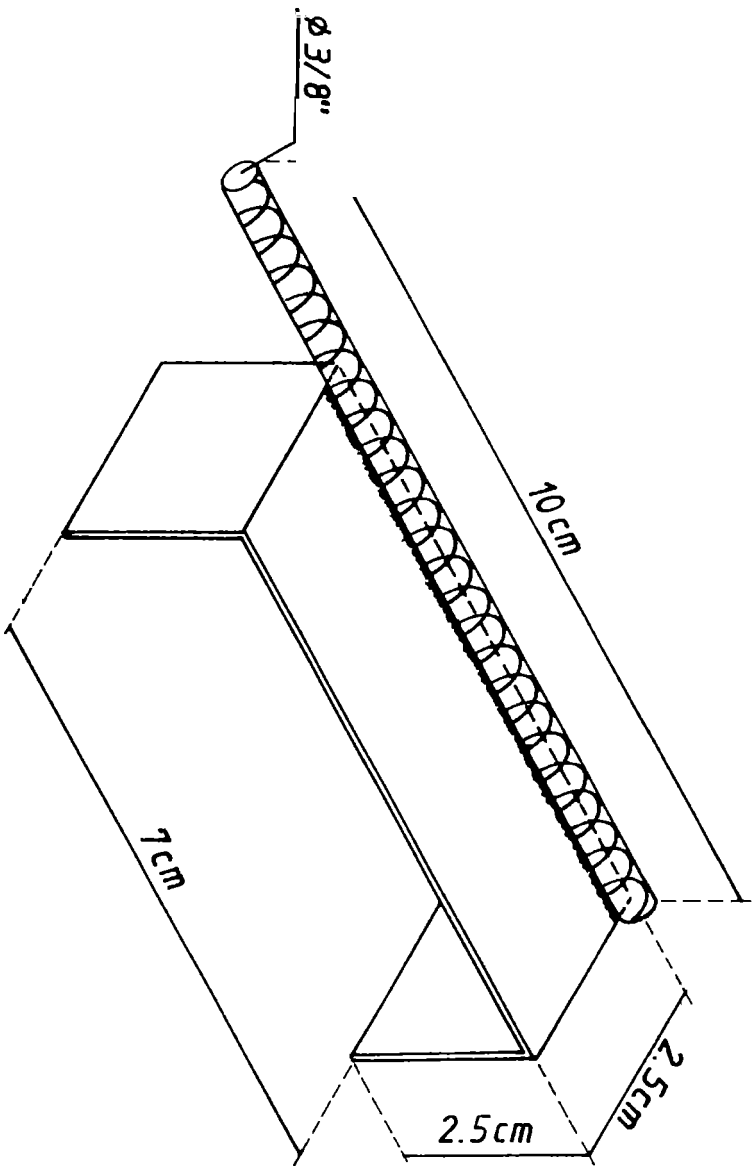



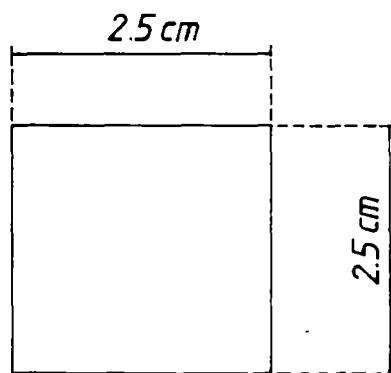
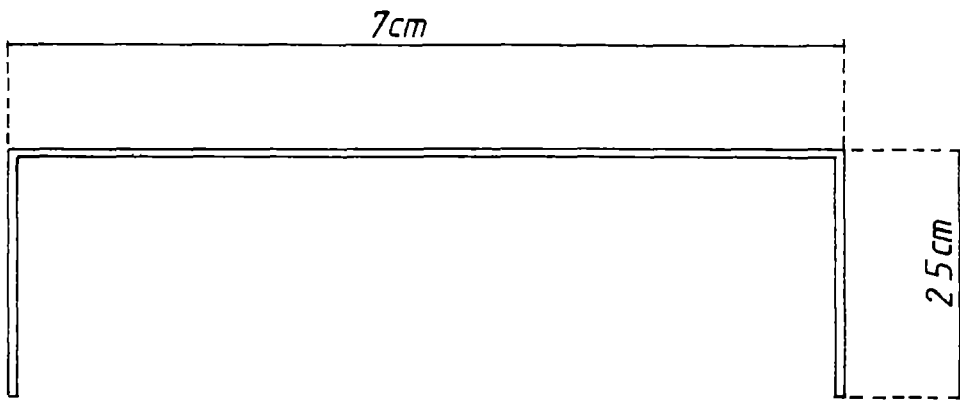
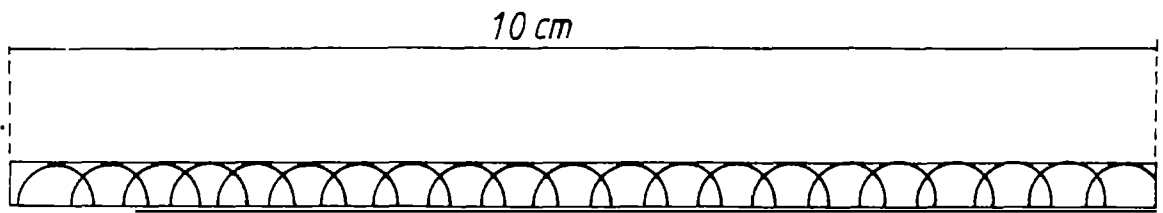



C.f. THE BRAKE SYSTEM

LIST OF MATERIALS

Amount	Materials	Measures	Section
6	Corrugated rod	3/8" x 10 cm	For the stop pins
1	Corrugated rod	3/8" x 15 cm	For the brake
1	Corrugated rod	3/8" x 10 cm	Lever
1	Pipes	1/2" x 2 cm	Bushings
1	Smooth rod	1/4" x 4 cm	Brake stop pin



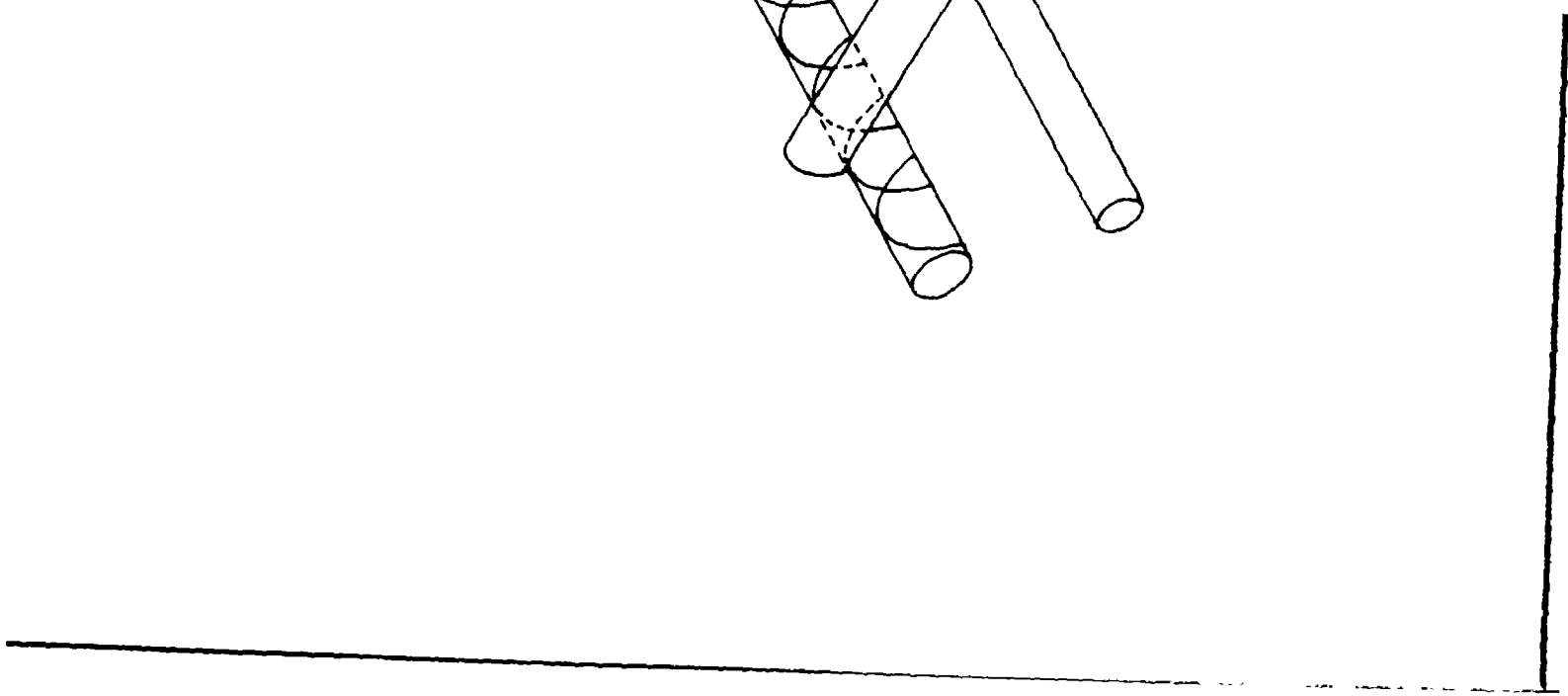
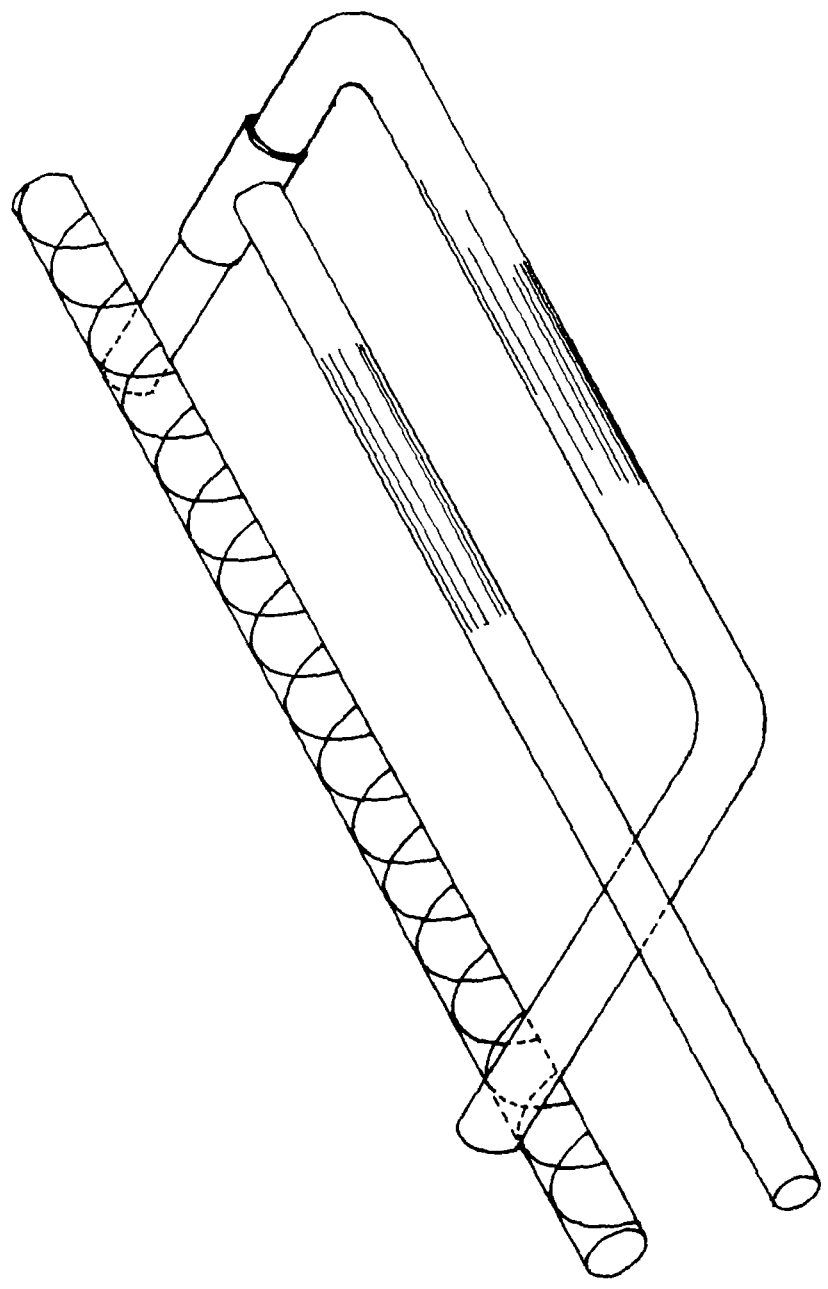



C-f-02

B.E.F

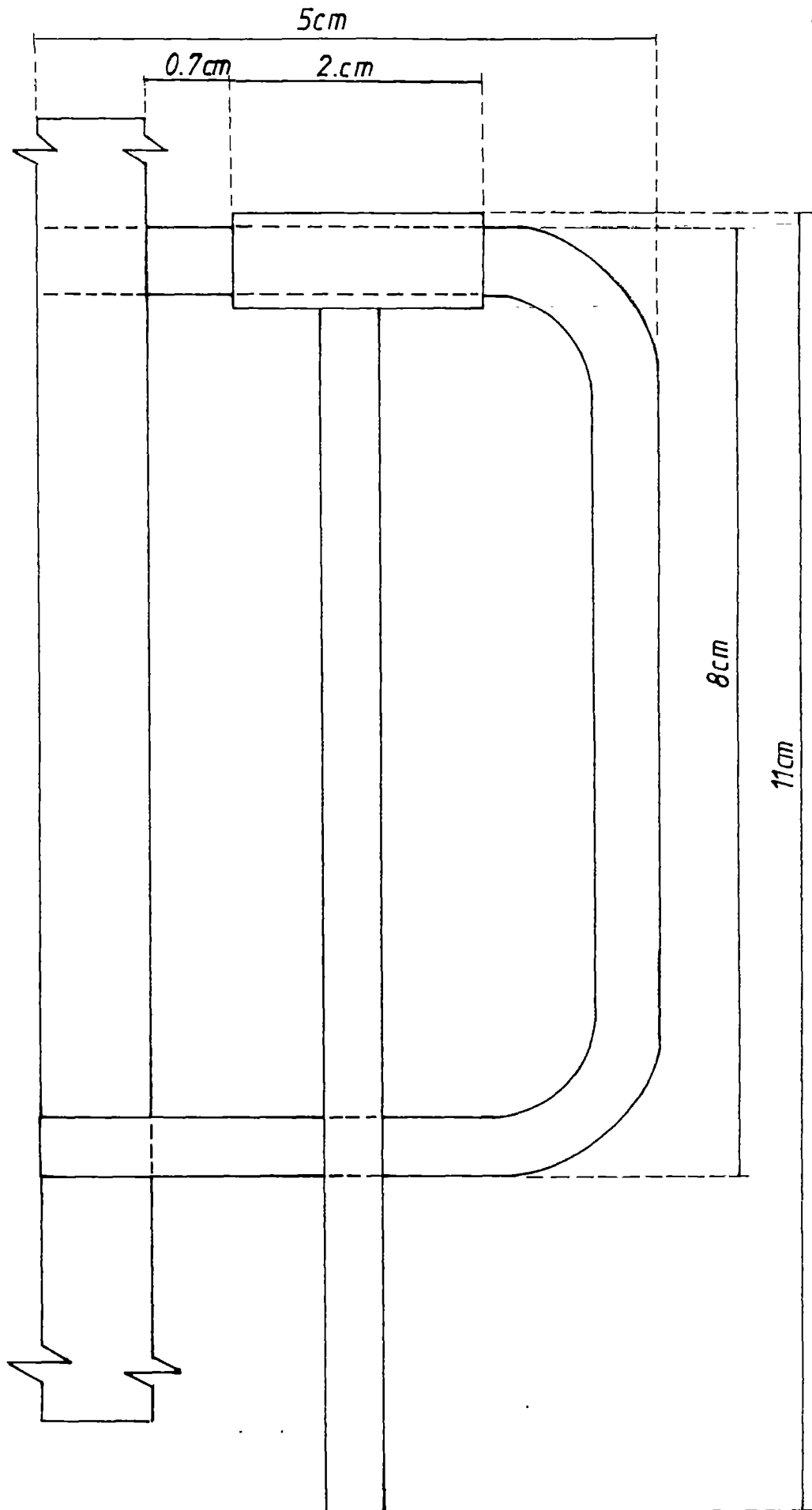

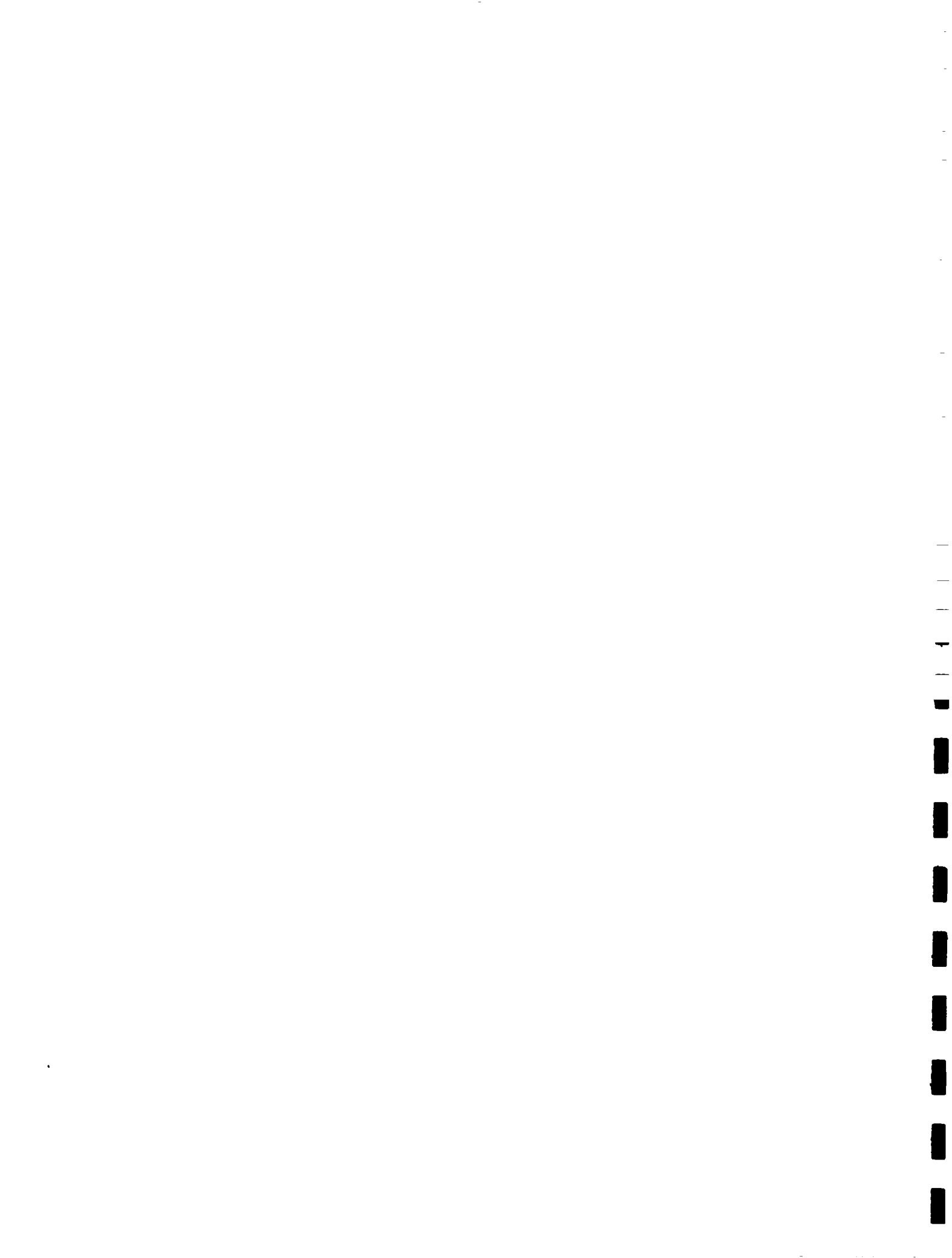

C.g. UPPER AND LOWER SUPPORTS

LIST OF MATERIALS

Amount	Materials	Measures	Section
1	Steel strip	1/8" x 1" x 70 cm	Upper support
2	Smooth rods	1/4" x 10 cm	Upper support clamp
2	Steel strips	1/8" x 1" x 10 cm	Clamps
2	Steel strips	1/8" x 3/4" x 6 cm	Clamp holders
2	Steel strips	1/8" x 1" x 30 cm	Lower supports
1	Black pipe	1 1/4" x 2.5 cm	For pumping pipe
1	Black pipe	1 1/2" x 2.5 cm	For return pipe

- The extra-strong pump has two upper supports and two lower supports which keep pipes in place.
- Nipple diameter varies with well depth. Three different size clamps are used for the upper support: 2" (0 - 11 meters), 1 1/2" (11 - 19 meters) and 1" (19 - 50 meters). They correspond to the PVC pipe nominal diameter.
- Return pipe diameter does not vary, thus just one clamp is used for the upper support for the 1 1/2" PVC pipe.
- The centre of the lower support for the pumping pipe has a nominal diameter of 1 1/4"
- The centre of the lower support for the return pipe has a nominal diameter of 1 1/2".



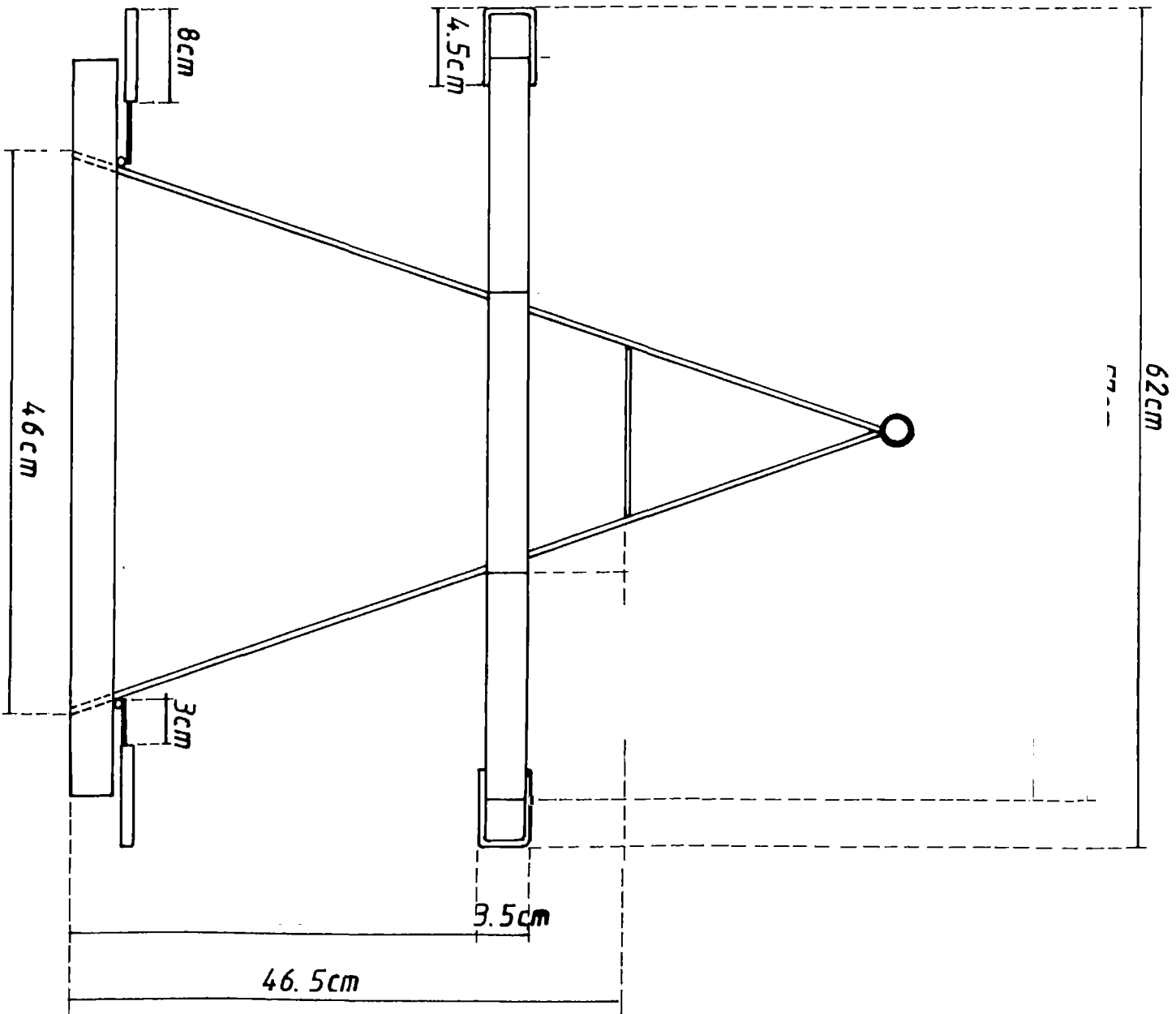



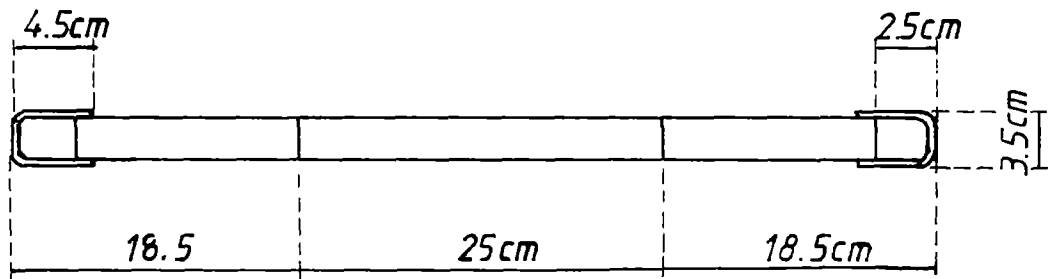
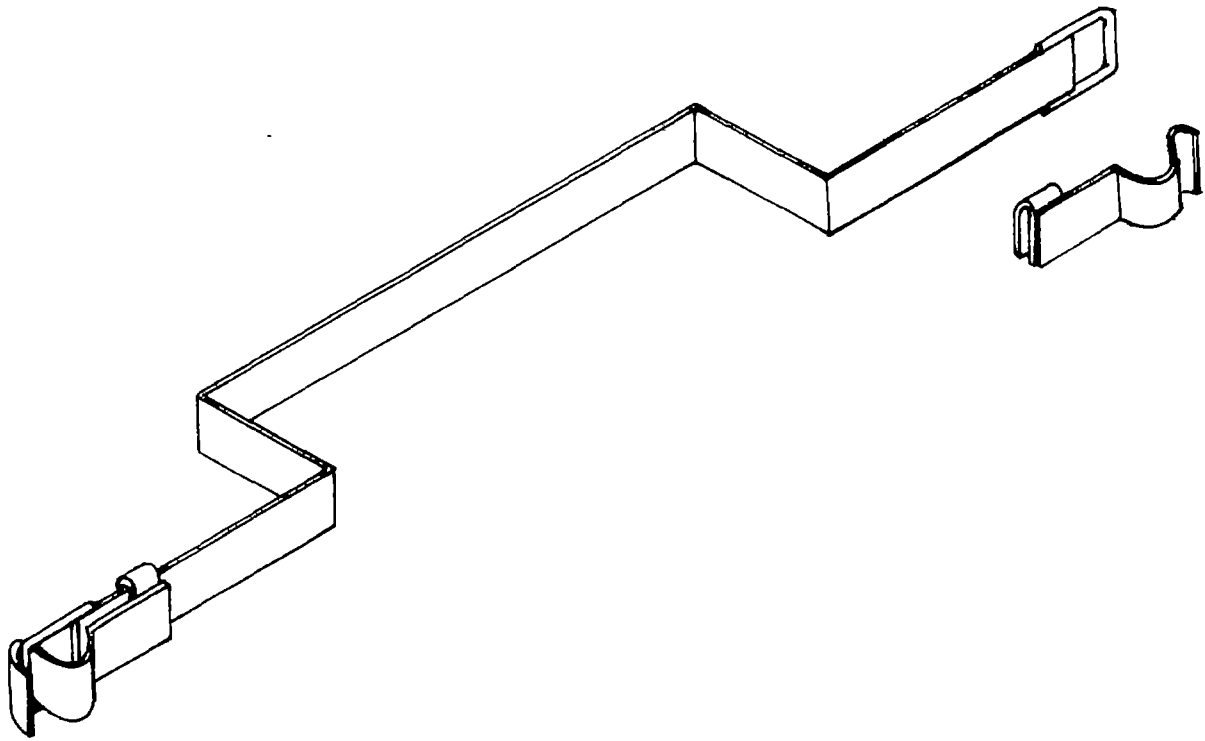



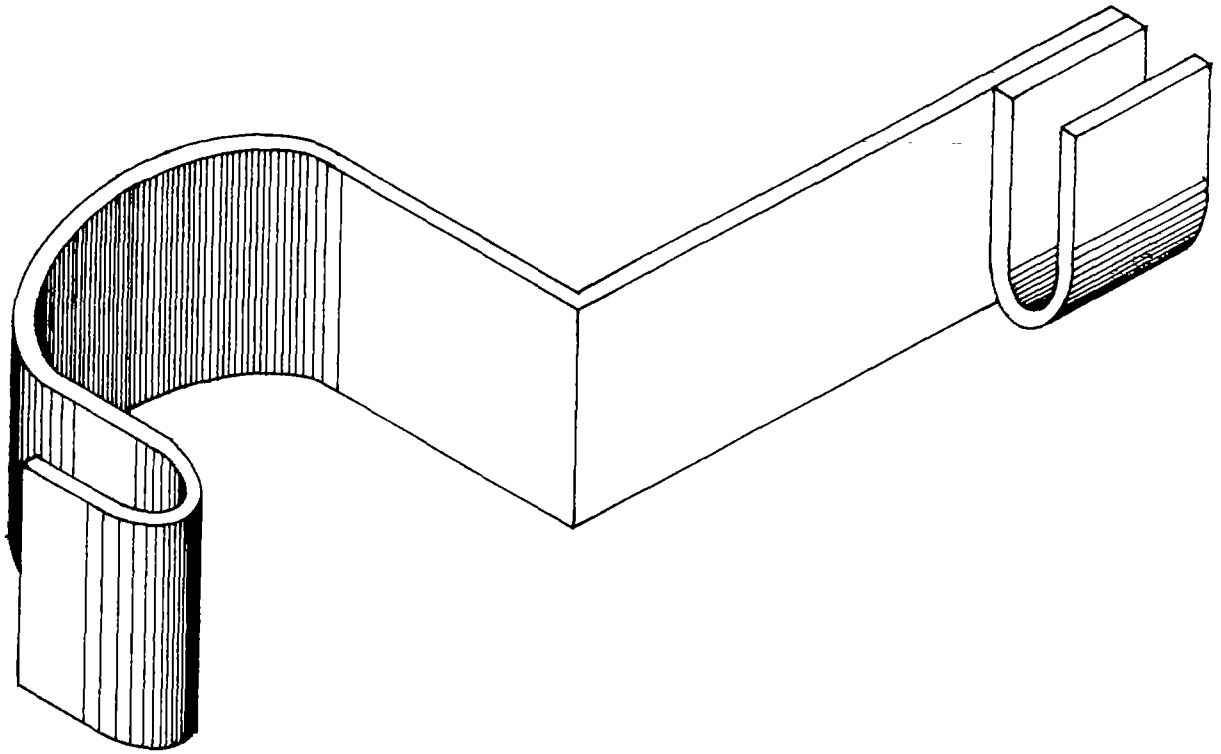



C-g-04

B.E.F

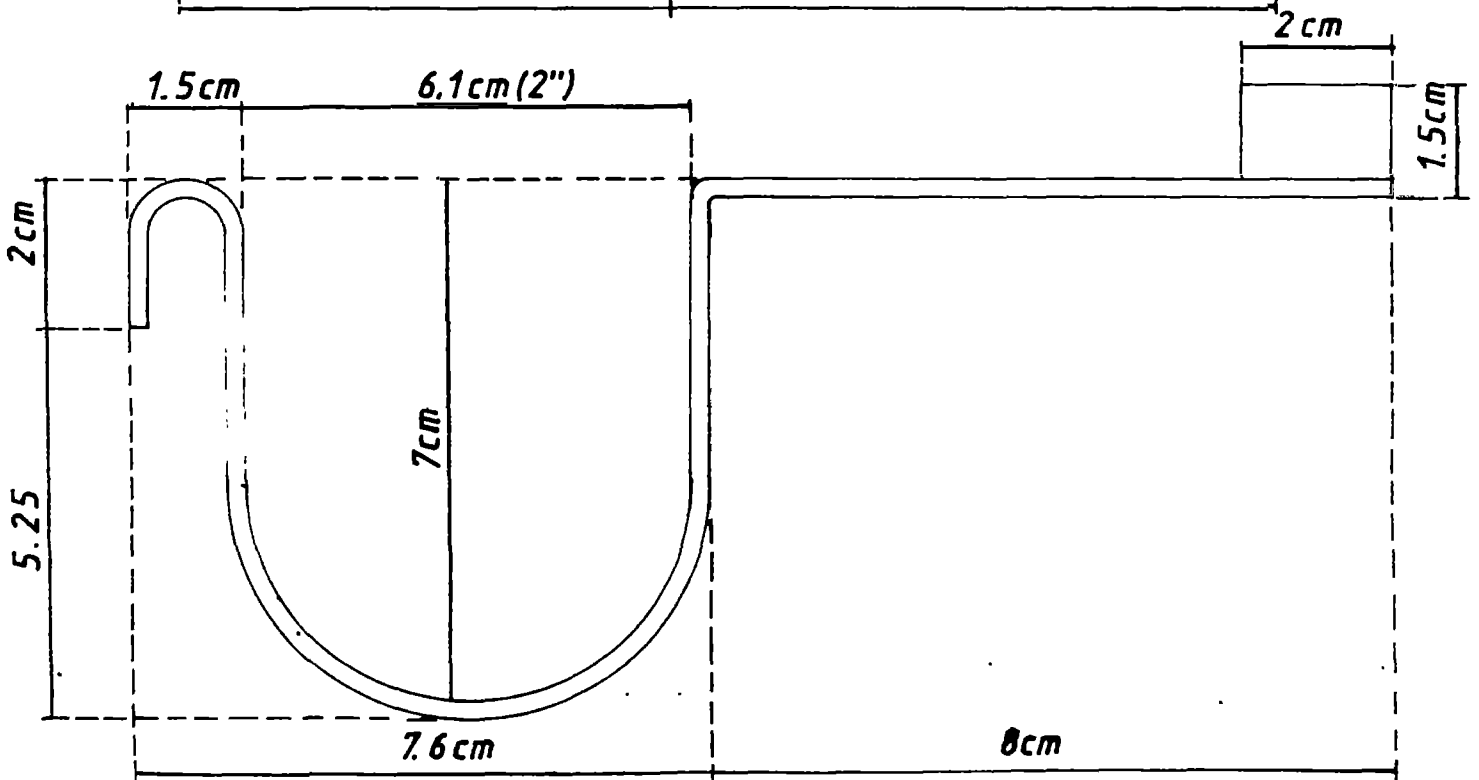
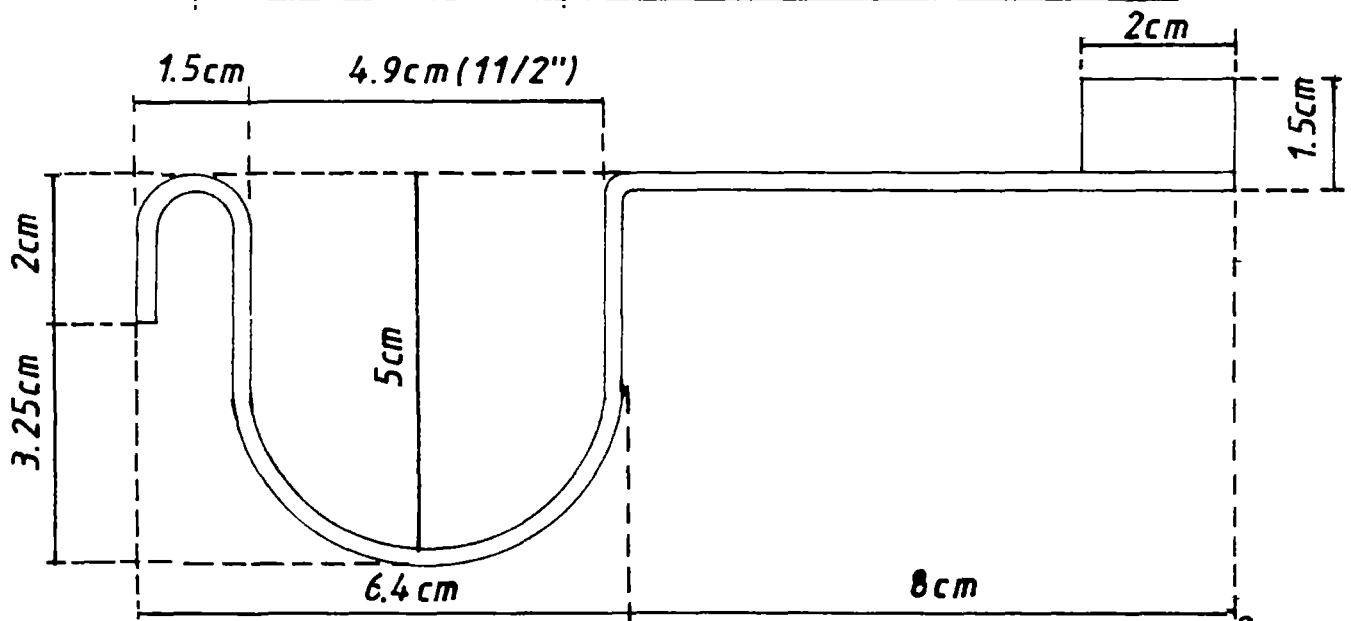
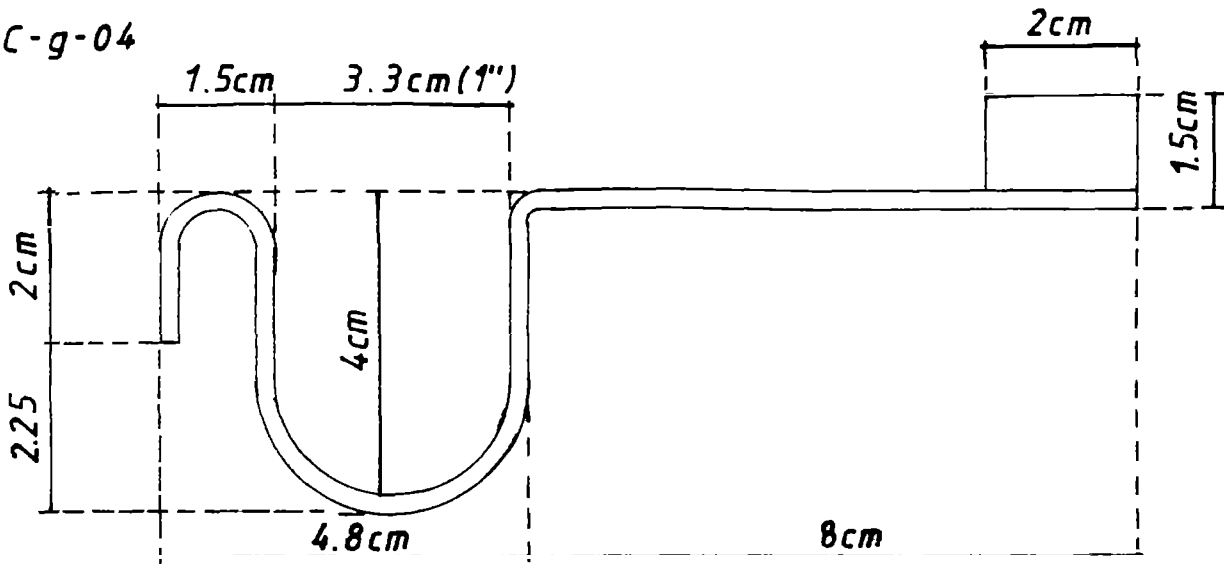



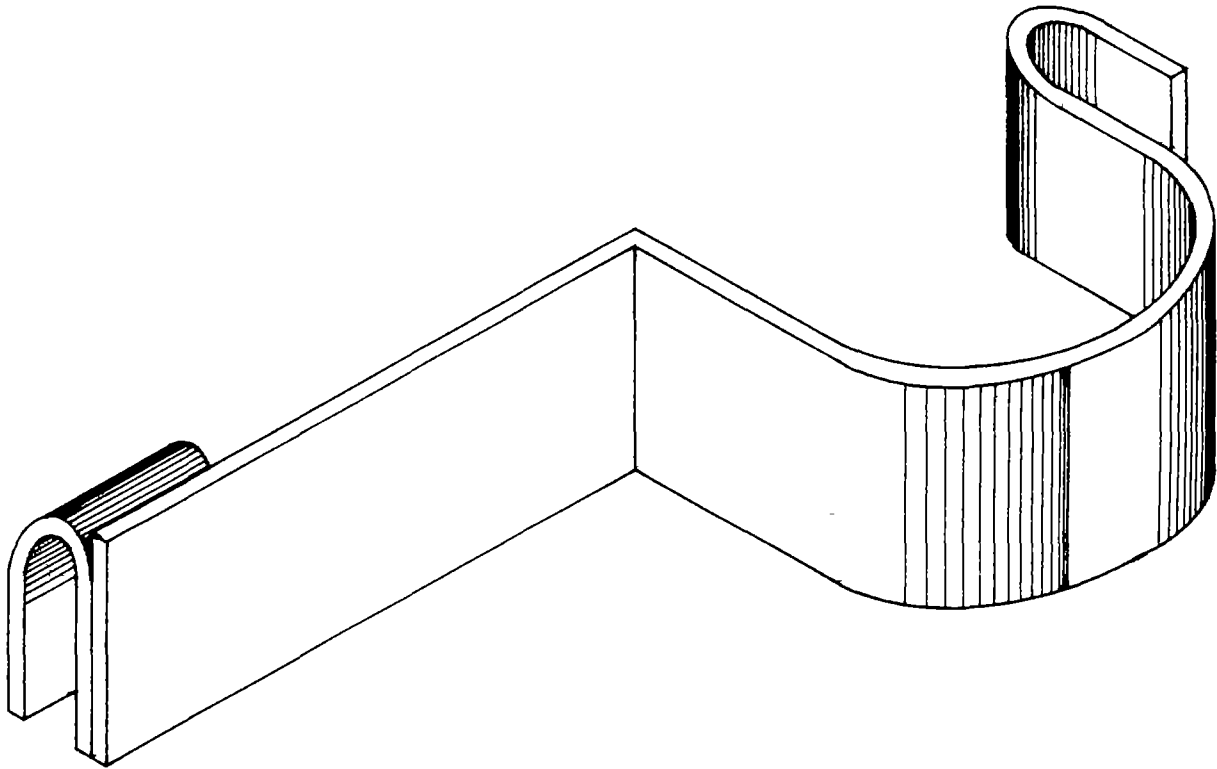
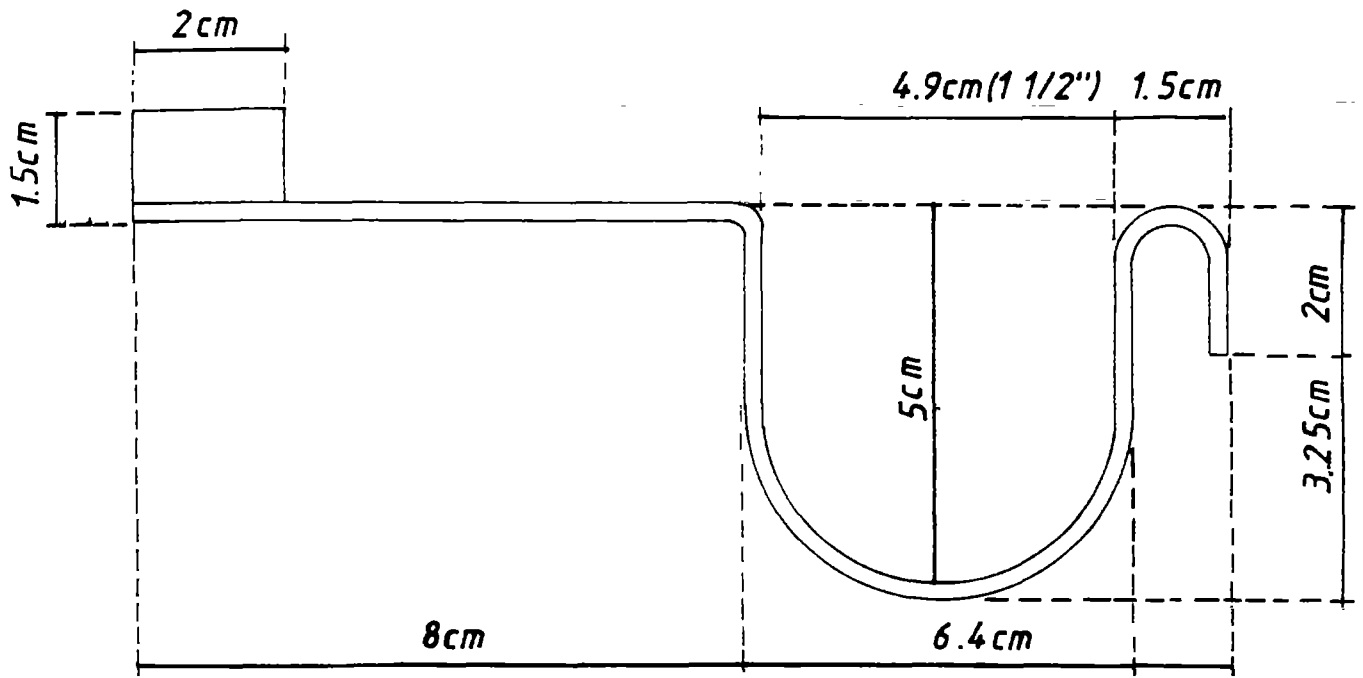



C-g-06

B.E.F.

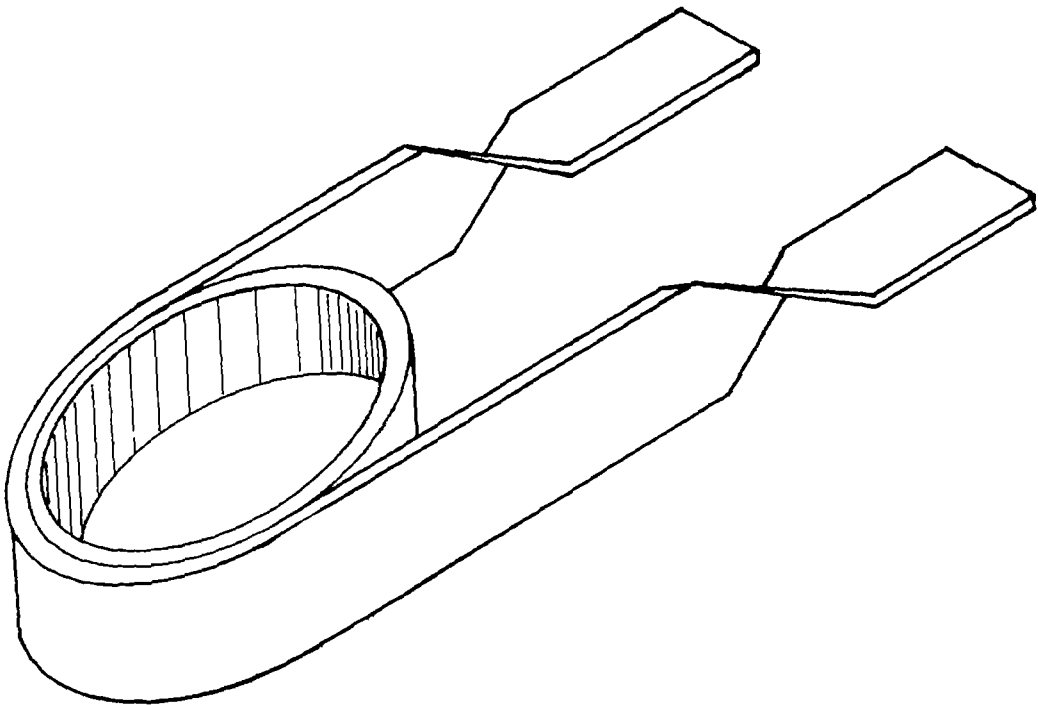



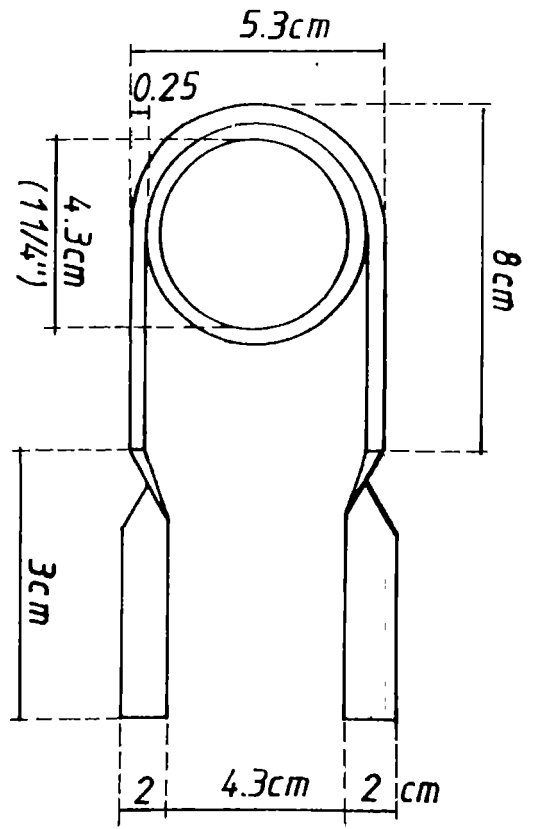
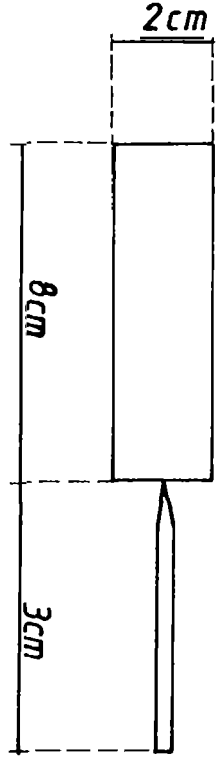
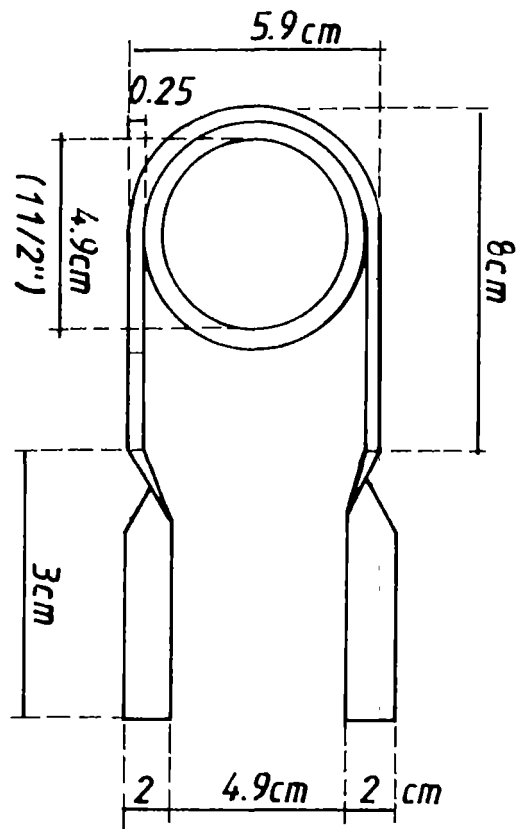
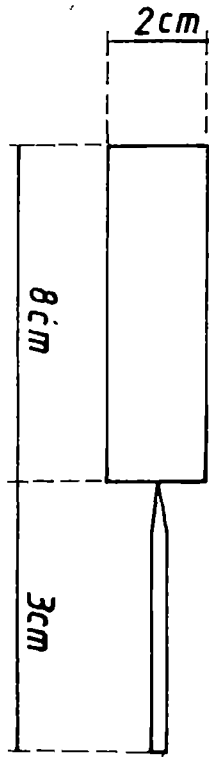



C.h. COVER FRAME

LIST OF MATERIALS

Amount	Materials	Measures	Section
2	Angle irons	1/8" x 1"x 80 cm	Frame
2	Angle irons	1/8" x 1"x 20 cm	Frame



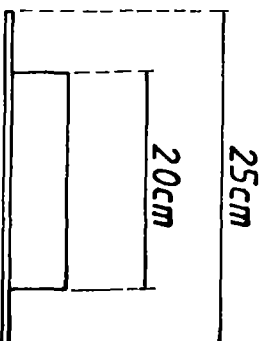
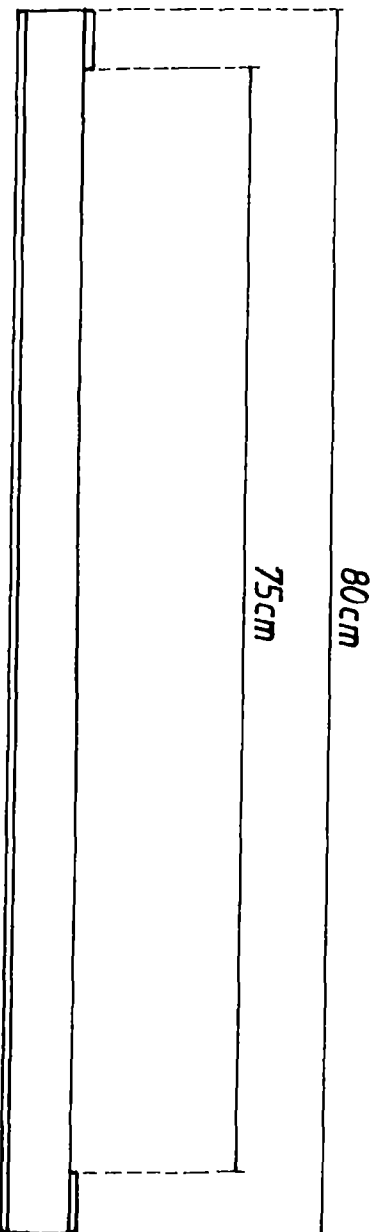
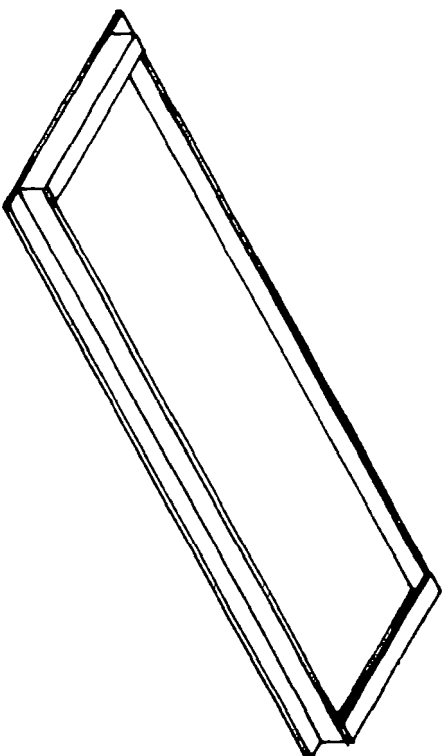



C.i. WHEEL COVER

LIST OF MATERIALS

Amount	Materials	Measures	Section
1	smooth zinc sheet caliber 24	40 cm. x 125 cm	Cover



C-i-01

B.E.F

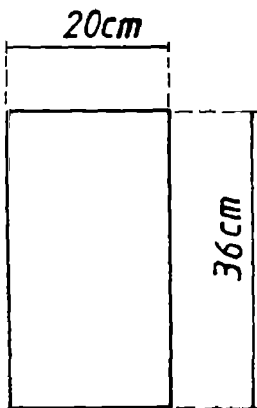
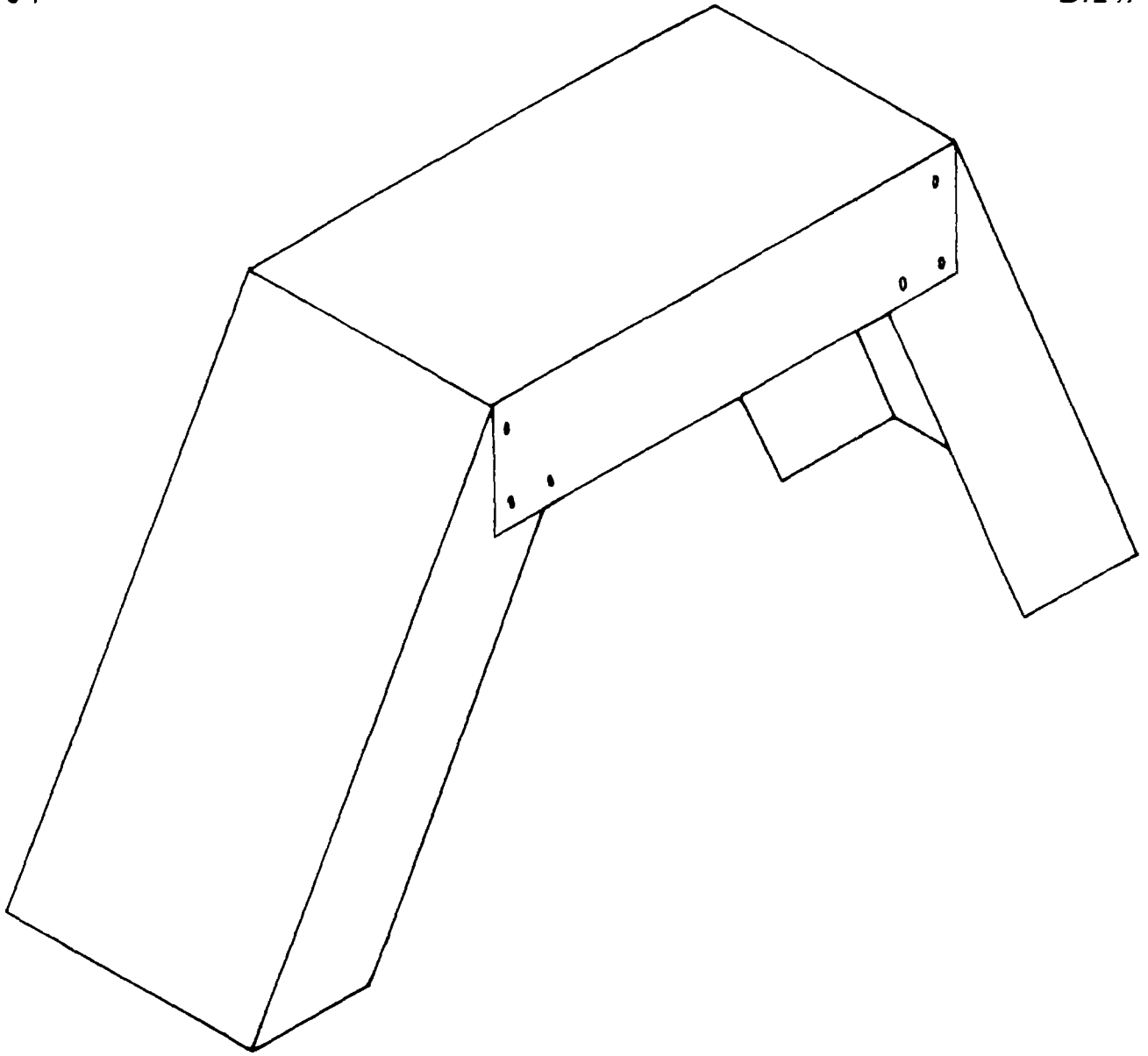

57 cm
80 cm



D. INSTALLATION ACCESSORIES

ROPE PUMP INSTALLATION (0 - 11 meter deep)

INSTALLATION ACCESSORIES

No.	Accessories	Unit	DEPTH
			0 - 11 Meters
1	Nipple	Inches	2 "
2	Tee	Inches	2 "
3	Discharge elbow	Inches	2 "
4	Discharge pipe	Inches	2 "
5	Reduction	Inches	2 - 1 "
6	Primary wedge	Inches	1 "
7	Secondary wedge	Inches	1 "
8	Supporting wedge	Inches	1 1/4 "
9	Pumping pipes	Inches	1 "

- Installation accessories vary according to well depth.
- The use of a concrete cover and drainage apron is recommended.



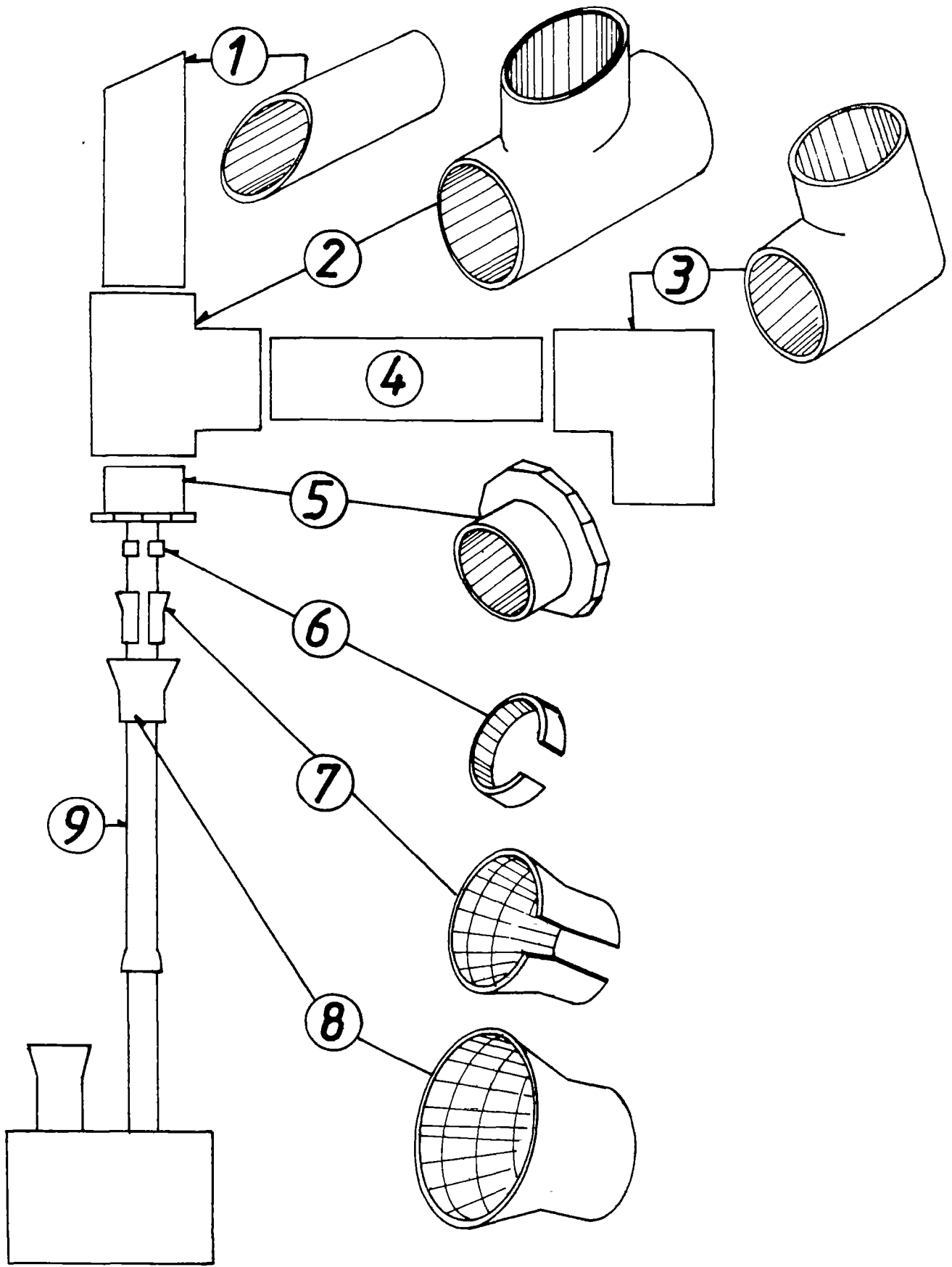



ROPE PUMP INSTALLATION
(19 - 50 meter deep)

INSTALLATION ACCESSORIES

No.	Accessories	Unit	DEPTH	
			11 - 19 meters	19 - 50 meters
1	Nipple	Inches	1 ½ "	1 "
2	Tee	Inches	1 ½ "	1 "
3	Discharge elbow	Inches	1 ½ "	1 "
4	Discharge pipe	Inches	1 ½ "	1 "
5	Reduction	Inches	1 ½ - 3/4 "	1 - ½ "
6	Primary wedge	Inches	3/4 "	½ "
7	Secondary wedge	Inches	3/4 "	½ "
8	Reduction	Inches	1 1/4 - 1 "	1 1/4 - 3/4 "
9	Pumping pipes	Inches	3/4 "	½ "

- Installation accessories vary according to well depth.
- Reduction number 8 is used to keep the pumping pipe in place in the lower support.
- The use of a concrete cover and drainage apron is recommended.

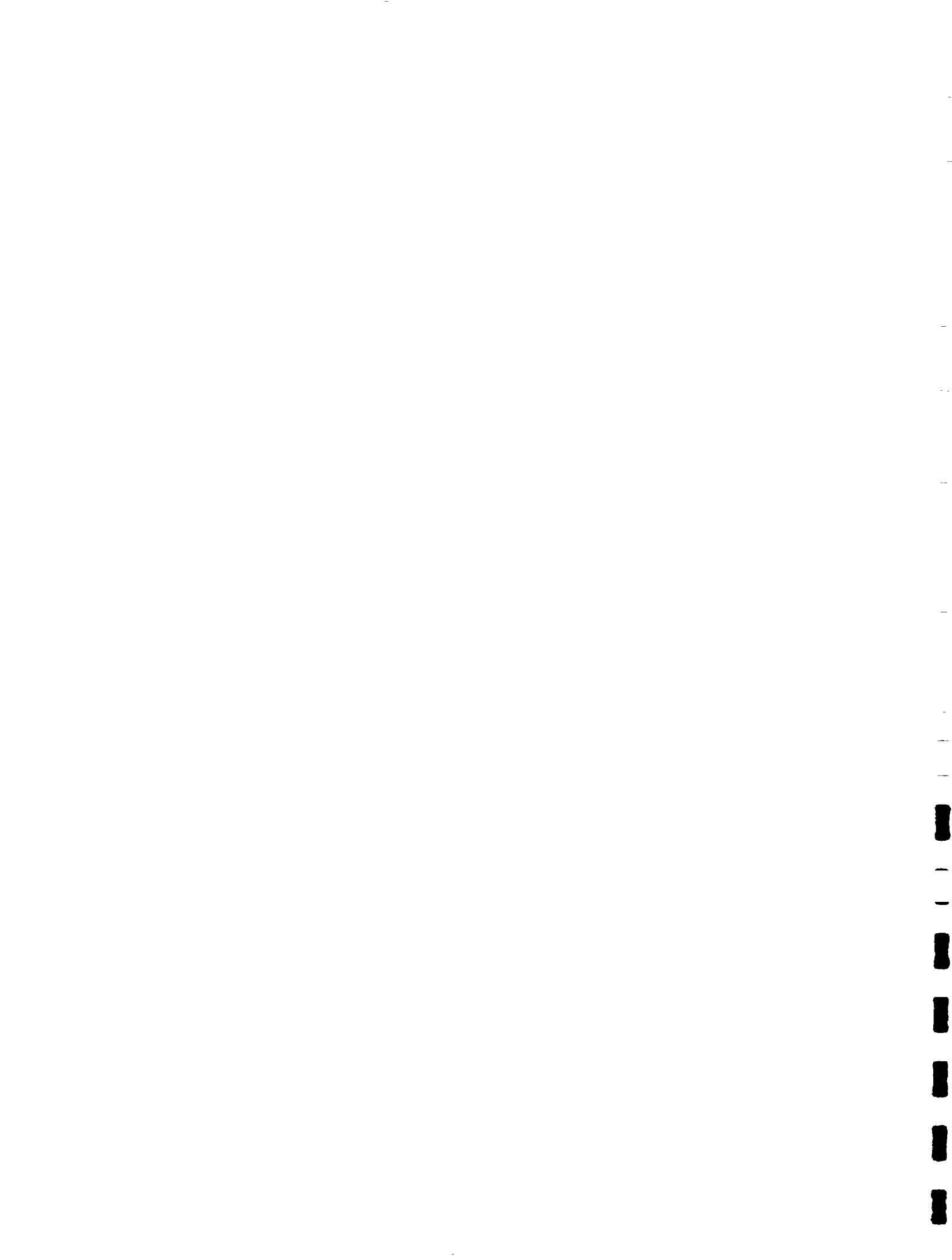

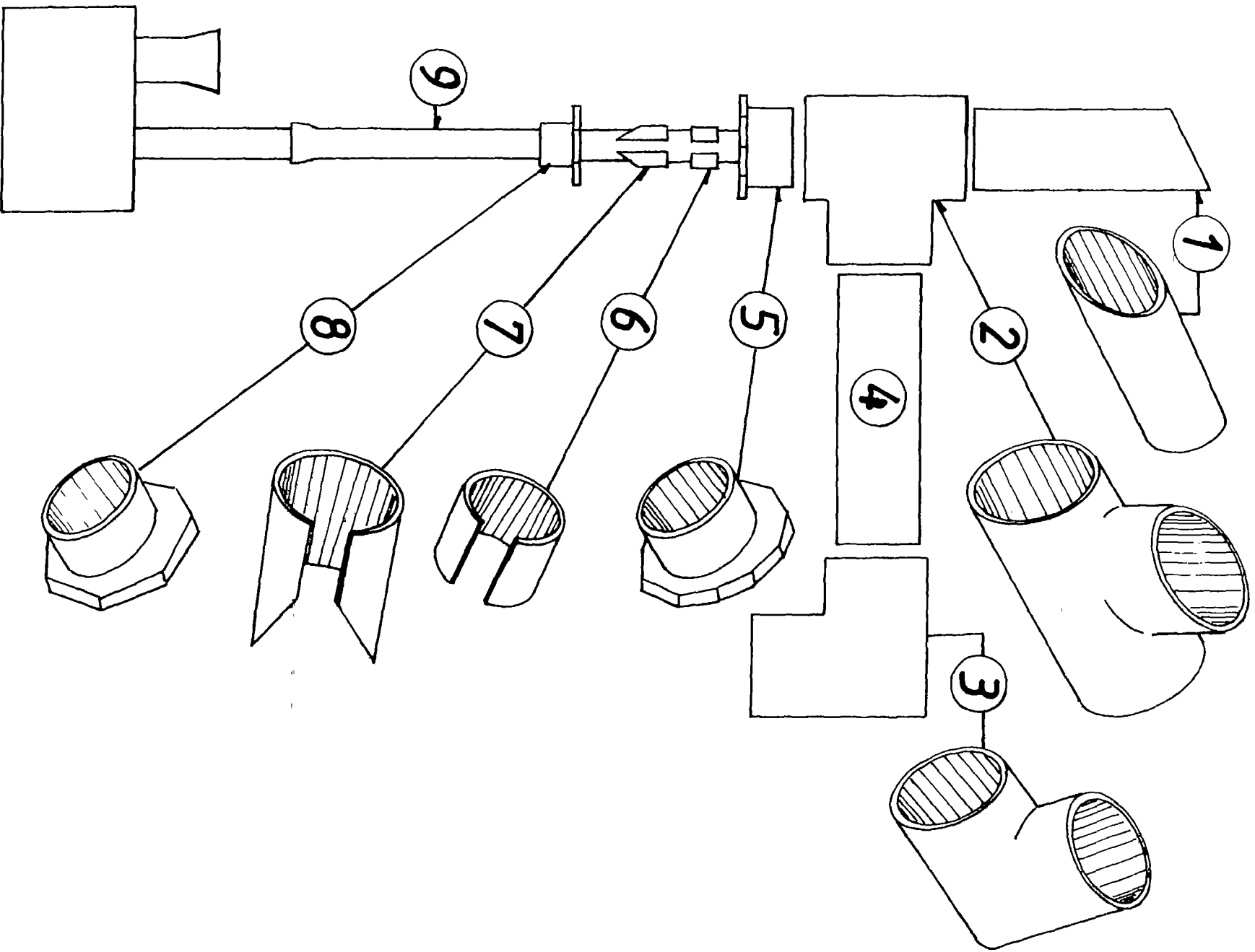



FAMILY WELL ROPE PUMP

MANUAL OF TECHNICAL DRAWINGS

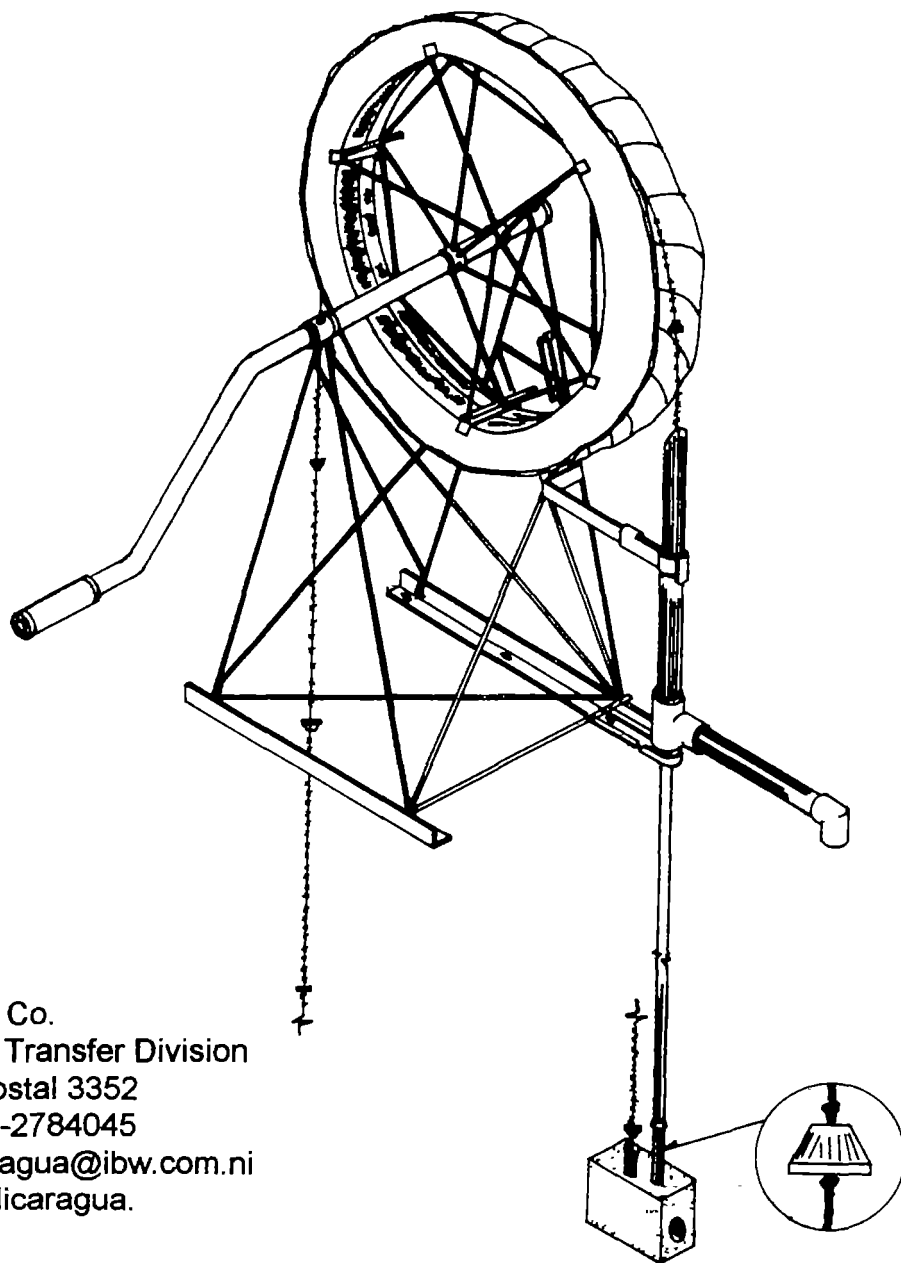

Rope Pump Co.
Technology Transfer Division
Apartado Postal 3352
Fax: 00-505-2784045
E-mail: sdcaagua@ibw.com.ni
Managua, Nicaragua.



COMMUNITY WELL ROPE PUMP

MANUAL OF TECHNICAL DRAWINGS

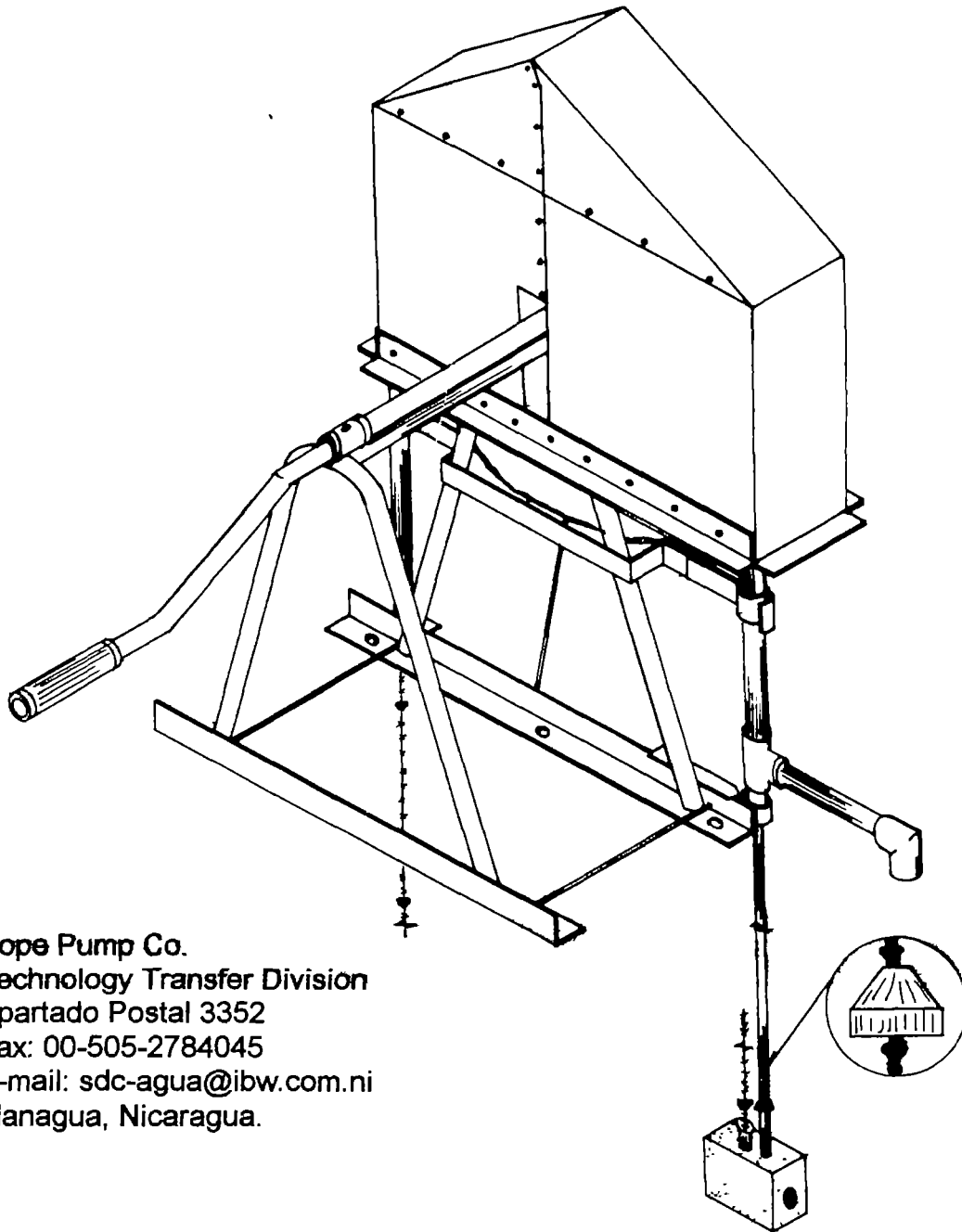

Rope Pump Co.
Technology Transfer Division
Apartado Postal 3352
Fax: 00-505-2784045
E-mail: sdc-agua@ibw.com.ni
Managua, Nicaragua.



