

JOB AIDS FOR THE INSTALLATION MAINTENANCE AND REPAIR OF THE AID HANDPUMP

WASH FIELD REPORT NO. 125

MAY 1984

WA' ON
FC JT



2 3 2 . . 2
8 4 J O



COORDINATION AND
INFORMATION CENTER

Operated by The CDM
Associates
Sponsored by the U S Agency
for International Development

1611 N. Kent Street, Room 1002
Arlington, Virginia 22209 USA

Telephone: (703) 243-8200
Telex No. WUI 64552
Cable Address WASHAID

The WASH Project is managed by Camp Dresser & McKee Incorporated. Principal Cooperating Institutions and subcontractors are: International Science and Technology Institute; Research Triangle Institute; University of North Carolina at Chapel Hill; Georgia Institute of Technology—Engineering Experiment Station.

232.2-1720-1

Prepared for:
Office of Health
Bureau for Science and Technology
U.S. Agency for International Development
Order of Technical Direction No. 82

Prepared by
Alan Pashkevich
with the assistance of

TABLE OF CONTENTS

<u>Chapter</u>	<u>Page</u>
Preface.....	i
Introduction.....	ii
Installation, Maintenance and Repair.....	1
Constructing the Apron.....	2
Installing the Pump.....	4
Repairing the Pump.....	7
Lubricating and Testing.....	9
Lubricating the Pump.....	10
Testing the Pump.....	11

PREFACE

Over the past few years AID has sponsored local manufacturing programs of the AID hand pump in a number of countries. In the Ecuador program under Order of Technical Direction No. 82, and as a part of the hand pump program AID requested WASH to develop training aids that would be for installation, operation, and maintenance of the AID hand pump. WASH in turn requested Georgia Tech to develop those training aids as part of its work under the Ecuador handpump program. This request resulted in the development of Job Aids for The Installation, Maintenance and Repair of the AID Hand Pump. Job aids for quality control in the manufacturing of the AID hand pump are also available (see WASH Field Report No. 124).

These job aids provide guidance in the performance of the tasks needed for installing, maintaining, and repairing the AID hand pump. They are intended for those individuals who carry out the tasks in the field. They are meant to be left with them after they have received training as a way to refresh their memories.

Although the job aids were developed under the Ecuador program, they are generic in that they can be used by anyone who is responsible for installing, maintaining, and repairing the AID hand pump. Because they focus on the critical steps and not every task involved, they should be transferable to other settings. It is hoped that these job aids will also serve as a model for other hand pumps or similar devices.

For cost and ease of distribution these job aids appear in the form of a report. When used in the field, the job aids should be printed on tear and stain proof paper so they can be used repeatedly.

INTRODUCTION

These job aids are intended to be used on the job by people who install, maintain and repair the AID hand pump.

The job aids serve as memory joggers for workers who have already received training in installation, maintenance, and repair tasks. Therefore, while the job aids contain the critical steps of the tasks, they may not include all of the information required to perform them.

The installation, maintenance, and repair job aids are likely to be used by technicians who work on installation or maintenance teams. The lubricating and testing job aids, on the other hand, are intended for village caretakers.

CONSTRUCTING THE APRON (PAGE 2)

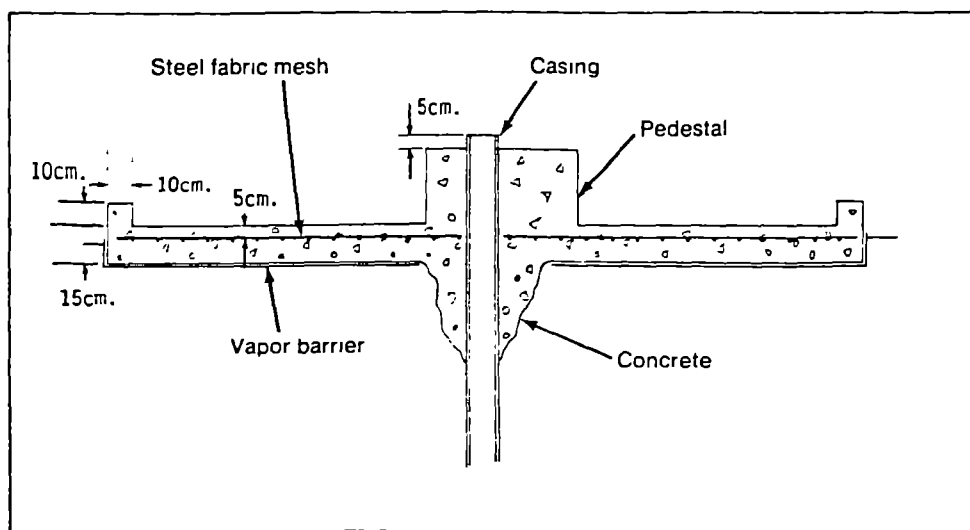
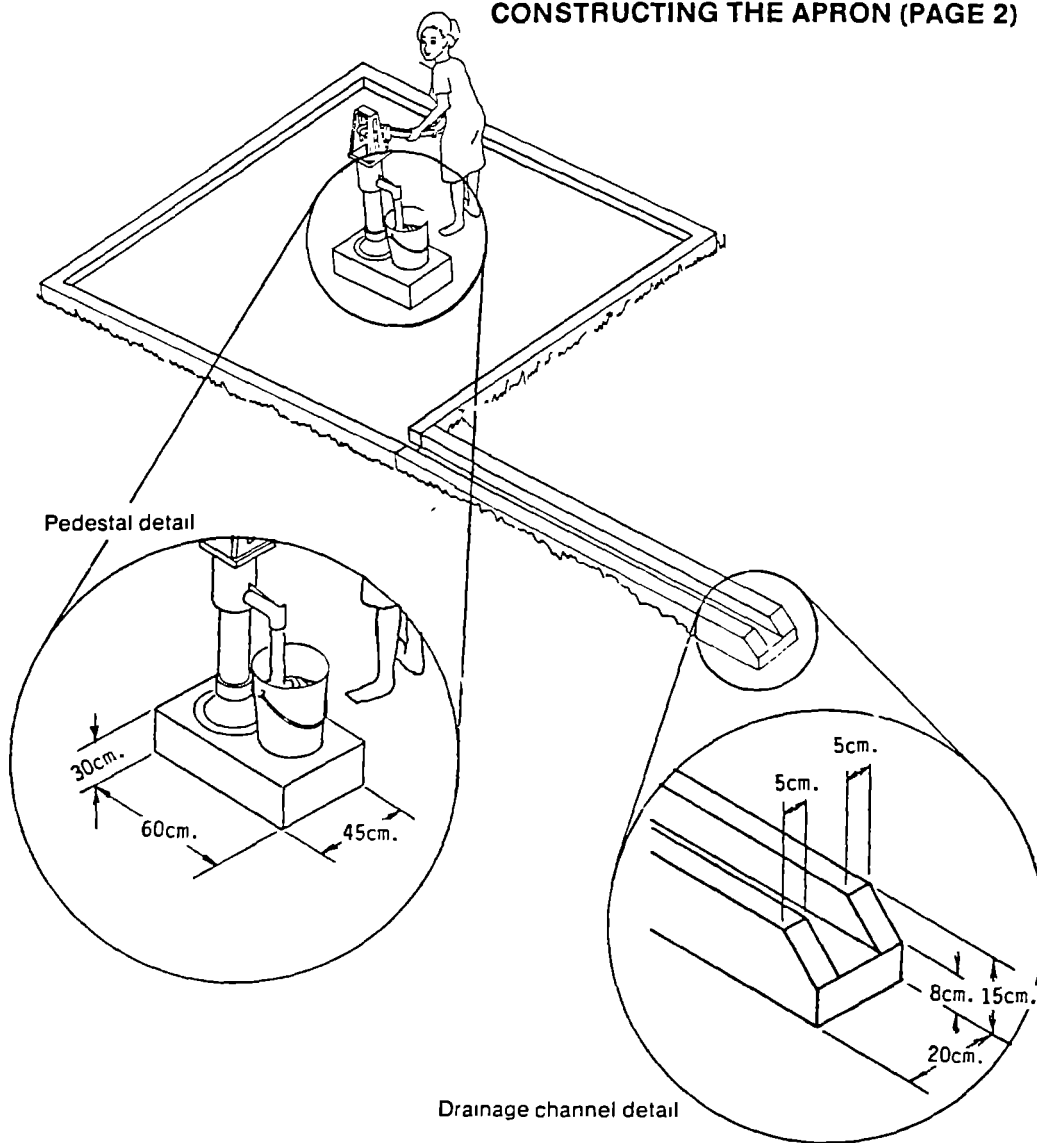

Apron cutaway detail

c. Continue adding sections of rod and pipe until desired depth is reached.

INSTALLING THE PUMP (PAGE 2)

3. Cut the plunger rod to length and thread it:
 - a. Push the plunger rod to full "down position "
 - b. Mark the plunger rod at 2.5cm. above the body of the pump.

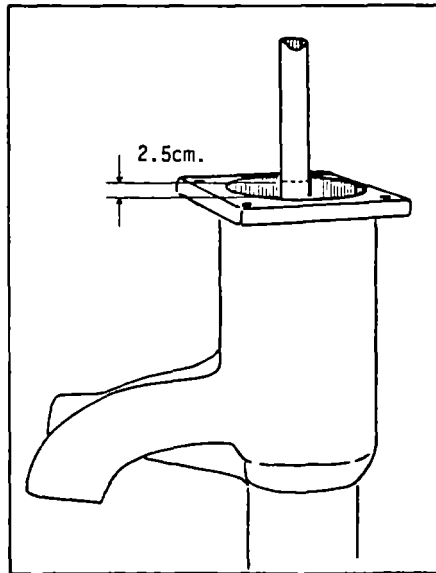

- c. Wrap a rag around the rod to cover the pump opening.
Then cut the excess rod away.

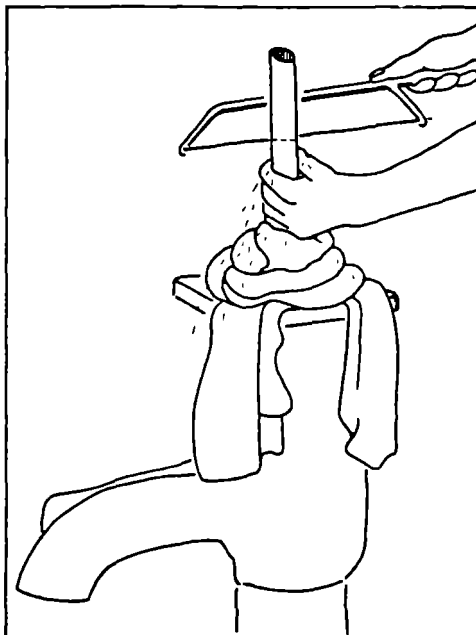

d. Thread the plunger rod

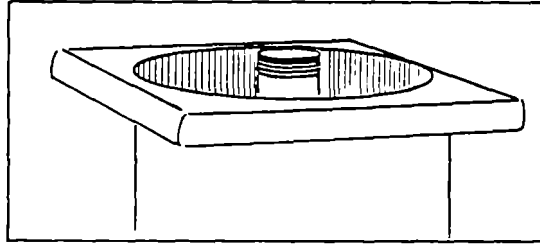

4 Put the cap on the pump, and attach the plunger rod to the handle.

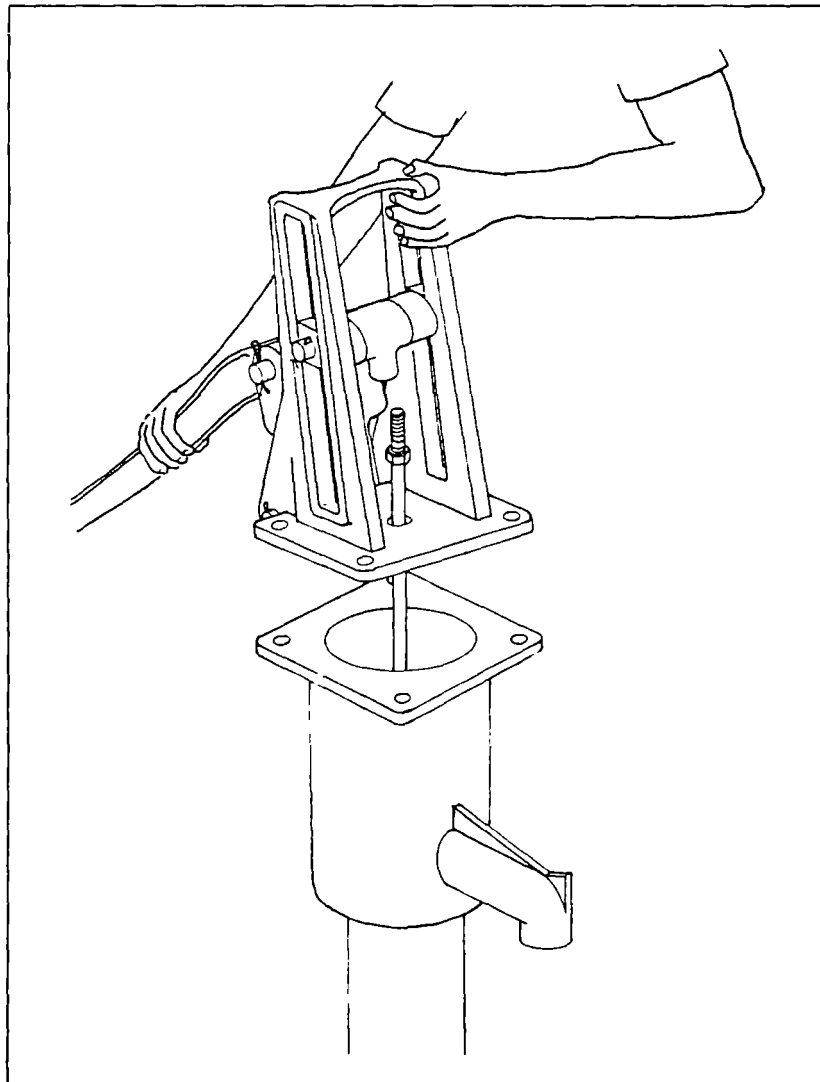

REPAIRING THE PUMP (PAGE 2)

3. Examine the plunger assembly for worn or broken parts.

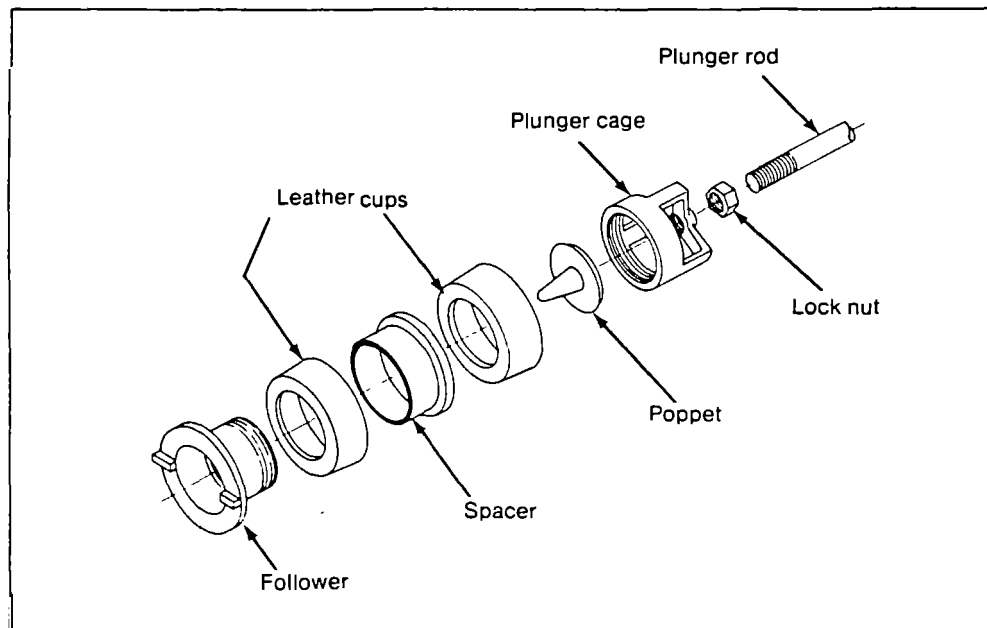

4. Double-check your repair.

- Did you see any pipe joints leak when you took the cylinder out of the well? Did you repair these?
- Did you examine **all** the cylinder components?
- Are all the pipe joints resealed with pipe sealant or teflon tape?
- Does the cylinder leak after reassembly?
- Are all the lock nuts tight?
- Are all rod joints tight?
- Are all pipe joints tight?
- Did you test the pump for smooth operation, flow rate and leak rate? Are they acceptable?

AID HAND PUMP

Lubricating and Testing Job Aids

LUBRICATING THE PUMP

First, clean off the old lubricant with a rag.

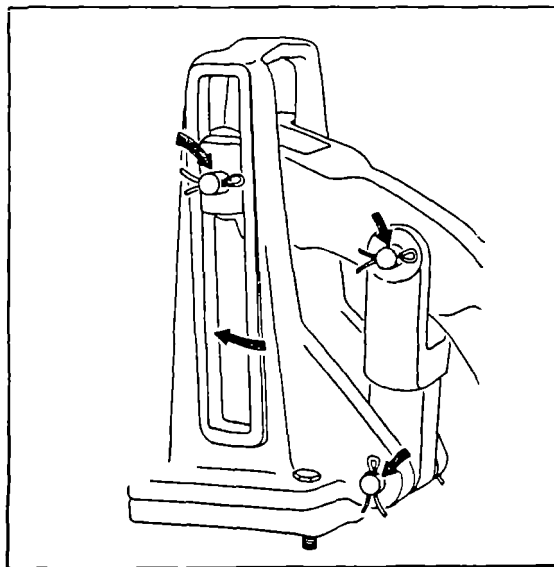
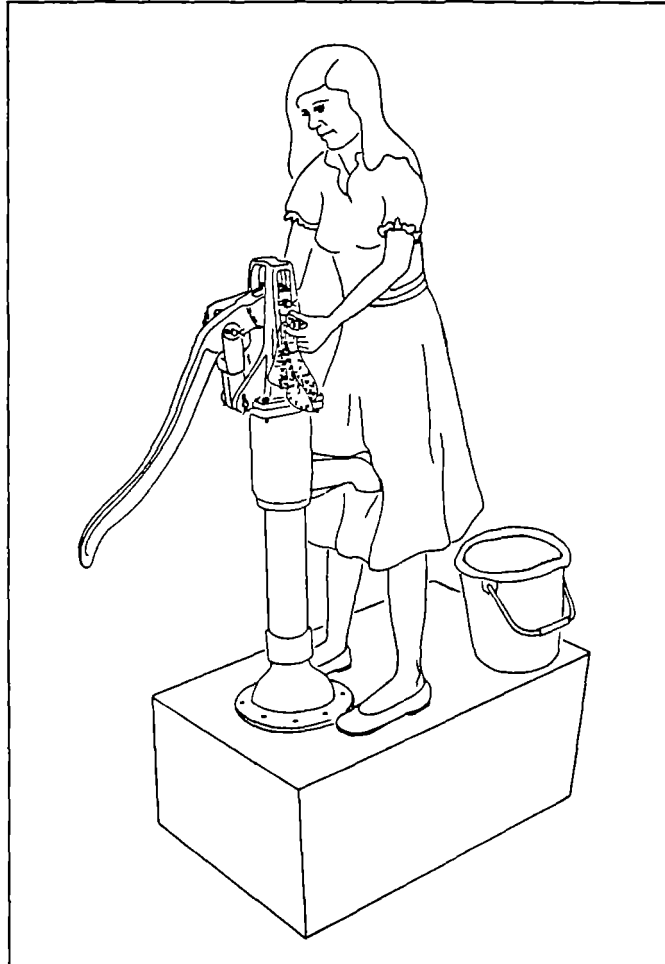

Put new lubricant on the parts indicated by the arrows

Remove the pins to lubricate them.

TESTING THE PUMP

Check these.

- The handle should move fully, as shown in this picture.
- Check the flow rate. You should be able to fill a 12 liter container in about 12 full strokes.
- Check the leak rate. Leave the pump alone for about 15 minutes, then start pumping again. You should have water after 2 or 3 strokes.

