

9332 I

232.2

75HY



VOLUNTEERS IN TECHNICAL ASSISTANCE

3706 Rhode Island Avenue
Mt. Rainier, Maryland 20822
U S A

A HYDRAULIC RAM FOR VILLAGE USE

by

Ersal W. Kindel

LIBRARY
International Reference Centre
for Community Water Supply

232-2/75HY
9332

9332

232.2

75HY

A HYDRAULIC RAM FOR VILLAGE USE

By

Ersal W. Kindel

LIBRARY
International Reference Centre
for Community Water Supply

(c) Volunteers in Technical Assistance 1970

Revised & Reprinted, 1975

HYDRAULIC RAMS

How They Work

A hydraulic ram is a simple device, invented about 150 years ago. It uses the power from falling water to force a small portion of the water to a height greater than the source. Water can be forced about as far horizontally as you desire, but greater distances require larger pipe, due to friction. There is no external power needed and the ram has only two working parts. The only maintenance needed is to keep leaves and trash cleaned away from the strainer on the intake and to replace the clack and non-return or delivery valve rubbers if they get worn. The original cost is almost the only cost.

Two things are needed to make the ram work: (a) enough water to run the ram and (b) enough height for water to fall through the drive pipe to work the ram. A small amount of water with plenty of fall will pump as much as a greater amount of water with only a little fall. The greater the height to which the water must be raised, the less water will be pumped, under a given set of circumstances.

Water may come from a spring on a hillside or from a river. It must be led into a position from which it can pass through a relatively short supply pipe to the ram, at a fairly steep angle (about 30° from the horizontal is good). Often a catch basin or cistern is used as the source for the drive pipe, but an open ditch such as that which supplies a water mill could be used. Be sure to put a strainer on top of the drive pipe to keep trash out of the pipe and ram.

The water starts to run down through the drive pipe, going faster and faster until it forces the automatic valve or clack, to close suddenly. The weight of the moving water, suddenly stopped, creates very high pressure and forces some of the water past the non-return or delivery valve and into the air chamber, compressing the air more and more till the energy of the moving water is spent. This compressed air acts as a spring and forces the water up the delivery pipe to the storage tank in a steady stream. It takes a lot of falling water to pump a little water up a hill. Often about one part in ten is delivered to the storage tank at the top of the delivery pipe. The snifter hole wastes a bit of water but takes in a bubble of air with each stroke. This is necessary to keep air in the air dome and it must not get plugged or the air dome will get filled with water and the ram will stop. The small ram works best at about 75 to 90 strokes per minute, depending on the amount of drive water available. The slower it goes, the more water it uses but the more it pumps.

Any working fall from 18 inches to 100 feet can be used to work a ram but, in general, the more working fall you obtain, the less the ram will cost and the less drive water it will require to raise a given amount of water. If there is plenty of water, a fall of four feet could be made to raise water 800 ft. but this would be an expensive installation. The following is a rough formula that will give an idea of the amount of water which can be

raised:

Driving water per minute in
gallons or liters x twice the
working fall in feet or meters = Amount of water
3 x vertical lift above raised by the ram
ram in feet or meters

EXAMPLE: Working fall = 18 ft; lift above ram = 200 ft.
driving water = 160 gal./min.

Water $\frac{160 \times 2 \times 18}{3 \times 200} = 9.6$ gal. or 13,824 gal.
raised per min. per 24 hours

100 gallons falling 10 ft. would elevate 10 gallons to 80 ft.

100 gallons falling 5 ft. would elevate 1 gallon to 300 ft.

Double the working fall and you just about double the water delivered.

An actual ram now in use is a very small one and has a small amount of water to run it, but there is plenty of fall and not very much lift.

Working Fall 20 ft., lift above the ram 44 ft. uses 8.4 gallons per minute.

Drive pipe 85 ft., run 690 ft., delivers 1-1/2 gallons/minute = 100 gal./hr. or 2400 gal. in 24 hours.

FACILITY SURVEY:

Unless you have practically unlimited water available, measure it exactly by making a temporary dam and putting a large pipe or two through it. Then catch and measure the water for, say, 15 minutes. Next sight along a carpenter's level to the top of a 10 ft. pole set on the ground down the hill at a lower level. Then move the level to the pole's position and sight again to the top of the pole, finding how many levels or fractions you have, and this will give you, when added together, the amount of fall for the drive pipe. Do the same for the height to which the water must be raised. This height is measured from the ram level.

This small ram you can make up yourself from pipe fittings and you only have to buy or build the clack and delivery valve assemblies.

Building the Ram

Start by building the clack valve shown in Figure 1. If you do not have a metal lathe, a machine shop will do the work for a small price. Chuck a 3" x 1" pipe bushing in the lathe and turn the inside smooth, where the clack strikes. Turn out the threads and eliminate any sharp edges. Drill two 1/4" holes near the end of a piece of steel 1/4" x 1 1/2" x 3" and, using it as a template, drill and tap holes in the top of the pipe bushing. Grind off the galvanizing, then bolt the clack spring support solidly to the bushing and braze it to the bushing for extra strength. Bend a 36" length of steel, 1 1/2" w x 1/8" thick around a 2" diameter pipe to make the clack spring. Drill two 1/2" holes through the end and also through both the support and two short pieces of steel to make up the pad as shown in the drawing in Figure 2. Cut pieces of rubber inner tube and assemble the sandwich A shown. This is to keep vibration from breaking the support off the pipe bushing. A brace can be added for additional support but is not absolutely necessary.

The clack valve itself is made up of a rubber disc, two metal washers, 3/8" smaller than the inside of your bushing and assembled on a 3/8" x 4 1/2" bolt. The best rubber is from an old tractor tire -- it can be cut on a band saw and sanded flat and even on a disc sander with coarse paper. (A similar one is used for the check valve). Slip the larger o.d. washer over the bolt, then the rubber, next the smaller washer, and the short 4" length of thin wall steel tube (3/4" o.d. conduit), with the ends filed exactly square. Then through a 3/8" dia. hole in the clack spring. Adjust by bending so the rubber clack strikes true and doesn't rub on the sides of the bushing.

Drill a hole for a carriage bolt to adjust the stroke of the spring; also a pair of holes about three inches from the round end of the spring for a tension bolt. If the bottom hole is filed square to fit the under side of the bolt, it will not turn when adjustments are made. Refer to Figure 2.

The check valve is similar in construction but a 1/2" x 2" galvanized bolt is used. Machine the lip true where the valve gasket rests, but do not cut it down farther than necessary. This gives a bit of clearance for the water to pass. **Drill two holes on each side of the middle for a 4" common nail to pass just above the valve metal washer, to keep it in place.** Leave enough clearance so the valve can open just below about 1/16". Mash the threads on the bolt with a center punch, just below the nut, so the nut can't work loose. Cut the nails off flush and file threads across their ends so the bushing will screw into the tee above it.

Just one other small job before assembly. Drill a 1/16" hole in the center of a 1" pipe nipple just below the check valve and bend a piece of copper wire to the shape of a cotter pin and insert it from the inside of the nipple with long nosed pliers. Spread the outside ends. This copper wire restricts the jet of water coming out, yet moves enough to keep the hole clean, most always.

The air dome can be a 2 ft. length of 3" pipe threaded on both ends with a cap on the top end, or the top end can have a plate welded over it. It must be airtight with no possible leakage. The inside of the pipe may be coated with asphalt paint to protect it from rust and to seal any small leaks in the weld. Let it dry in the sun while assembling the rest of the ram.

Assembly:

Use plenty of good grade pipe joint compound, both on inside and outside threads. Screw things together firmly but not excessively tight, and leave them in the correct position for your installation. Set the ram reasonably level but precision is not required. The snifter hole must be immediately below the air dome so the bubbles will go up into the dome. Clack and check valves must be free from binding and touch evenly all around. The tractor tire rubber with some fabric on the back seems to be just the right toughness and resiliency to last a long time -- much longer than either gasket rubber or live rubber.

There is no reason to mount the ram in concrete --in fact it is a convenience to be able to shut off the two valves, loosen the unions and take the ram to the shop for cleaning and painting. The cost of a home-built ram is about 1/10th the cost of a purchased ram and it works at no cost at all. A bit of rubber stretched over the head of the stroke bolt quiets the ram, but isn't essential. Adjust the spring tension bolt and stroke bolt together to get the best period for your particular ram. Support the drive and delivery pipes so they don't bounce and vibrate.

This is a small ram but larger ones can be built --one was built with 3" drive pipe and correspondingly larger ram parts. It lifts water about 150 ft. and drives it through 3600 ft. of pipe.

Installation & Adjustments

The drive pipe should have a strainer on the top made of 1/2" coffee tray wire, hardware cloth or anything suitable. This keeps out the trash, frogs, and leaves, any of which will stop the ram if they get inside. The drive pipe should be 1 1/2" or larger and, if possible, new, solidly put together, straight and well supported throughout its length. A gate valve on the drive pipe about 4 feet from the ram is a great convenience but not necessary. Another gate valve on the delivery pipe is almost a necessity to avoid draining the entire delivery pipe whenever the ram is cleaned. The ram should be connected to the delivery and drive pipes by unions so it can be removed for cleaning. If it is desirable to use two rams, they must have separate drive pipes but the delivery pipes can be joined, provided the pipe is large enough to carry the water.

The delivery pipe should start from the ram with about two lengths of 1" galvanized iron pipe. From there 3/4" plastic pipe can be used. The iron pipe will give the ram better support, but plastic pipe is smoother inside and can be a size smaller than the iron pipe. Plastic pipe is cheaper, but it must be protected from mechanical injury and sunlight. (In some areas white ants will eat any but PVC plastic pipe!) Do not take any branches off the supply line at less than 3 times the working fall or when the tap is turned on the ram will stop. (A float valve might be an exception). Best results will be obtained by putting all the water from the ram directly

into a storage tank and using it from there.

The small bolt at the end of the clack spring controls the length of the stroke of the ram. The bolt at the back (rounded) end of the spring controls the **tension** of the clack spring. Experiment for the best length of stroke and tension for your set of conditions. Adjust the length of stroke first, then the spring tension. The greater the tension and length of stroke, the slower the ram will work and the more water it will pump, but it will take more water to keep it working. (Refer Figure 1 and 2).

If Action is Faulty

See that the clack valve closes squarely evenly and completely. If it does not, the clack spring may have been bent somehow, and it will have to be straightened.

See that the clack valve does not rub on the front, side or back of the valve body inside.

Check for trash in the ram, delivery valve or snifter hole.

Check to see that the air dome is not filled with water. It must not be full of water or the ram will knock loudly and may break something. The snifter lets in a bit of air between each of the strokes and this keeps the dome full of compressed air.

Check rubber clack and delivery valve for **wear** or looseness.

If drive water is in small supply, speed up the stroke by loosening spring tension and shorten the **stroke** by lowering the stroke adjusting bolt. More water is delivered by a faster stroke and continuous running than a slower stroke.

Check for leaks in drive pipe. If air bubbles come out of the drive pipe after it has been stopped for a while, air is leaking into the drive pipe and the ram action is rendered faulty.

Clean the ram once in a while. It deserves it after working without rest day and night for weeks and months on end. Protect it from outside injury and inquisitive children.

When the ram **runs out** of water, it will usually stop, remaining open and losing all the water available until it is closed again. You can listen at the storage tank to hear if it is still running and if it isn't, go to the ram and close the drive pipe until water has accumulated in the cistern.

Long delivery distances require larger pipe to reduce friction (known as pressure drop).

A cistern is a good thing to have at the top of the drive pipe to let dirt settle out of the water. The outlet from the cistern to the ram should be a foot or so above the bottom to allow room for dirt to settle out. A cleaning drain in the bottom of the cistern is a good feature. The cistern should be cleaned periodically.

HYDRAULIC RAM IN OPERATION

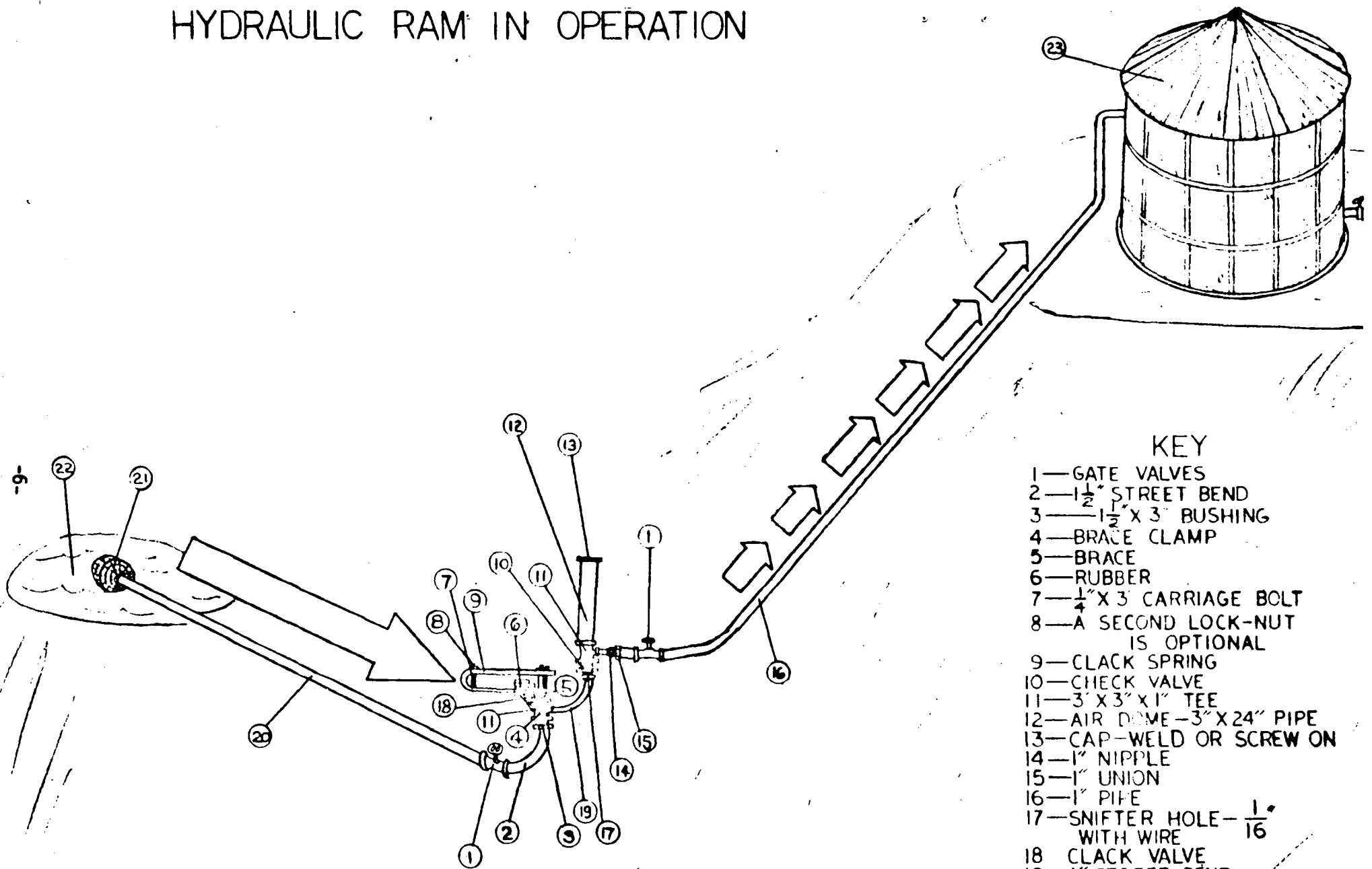

KEY

- 1—GATE VALVES
- 2— $1\frac{1}{2}$ " STREET BEND
- 3— $1\frac{1}{2}$ " X 3" BUSHING
- 4—BRACE CLAMP
- 5—BRACE
- 6—RUBBER
- 7— $\frac{1}{4}$ " X 3" CARRIAGE BOLT
- 8—A SECOND LOCK-NUT IS OPTIONAL
- 9—CLACK SPRING
- 10—CHECK VALVE
- 11—3" X 3" X 1" TEE
- 12—AIR DOME—3" X 24" PIPE
- 13—CAP—WELD OR SCREW ON
- 14—1" NIPPLE
- 15—1" UNION
- 16—1" PIPE
- 17—SNIFTER HOLE— $\frac{1}{16}$ " WITH WIRE
- 18 CLACK VALVE
- 19 1" STREET BEND
- 20 $1\frac{1}{2}$ " PIPE
- 21 STRAINER
- 22 SOURCE
- 23 STORAGE TANK

DWG. BY GRANT FULLMAN

HYDRAULIC RAM ASSEMBLY DRAWING

KEY

- 1—GATE VALVES
- 2—1 1/2" STREET BEND
- 3—1 1/2" X 3" BUSHING
- 4—BRACE CLAMP
- 5—BRACE
- 6—RUBBER
- 7—1/4" X 3" CARRIAGE BOLT
- 8—A SECOND LOCK-NUT IS OPTIONAL
- 9—CLACK SPRING
- 10—CHECK VALVE—SEE DETAIL.
- 11—3" X 3" X 1" TEE
- 12—AIR DOME 3" X 24" PIPE
- 13—CAP WELD OR SCREW ON
- 14—1" NIPPLE
- 15—1" UNION
- 16—1" PIPE
- 17—SNIFTER HOLE — 1/16" WITH WIRE INSERT
- 18—CLACK VALVE—SEE DETAIL
- 19—1" STREET BEND
- 20—1 1/2" PIPE

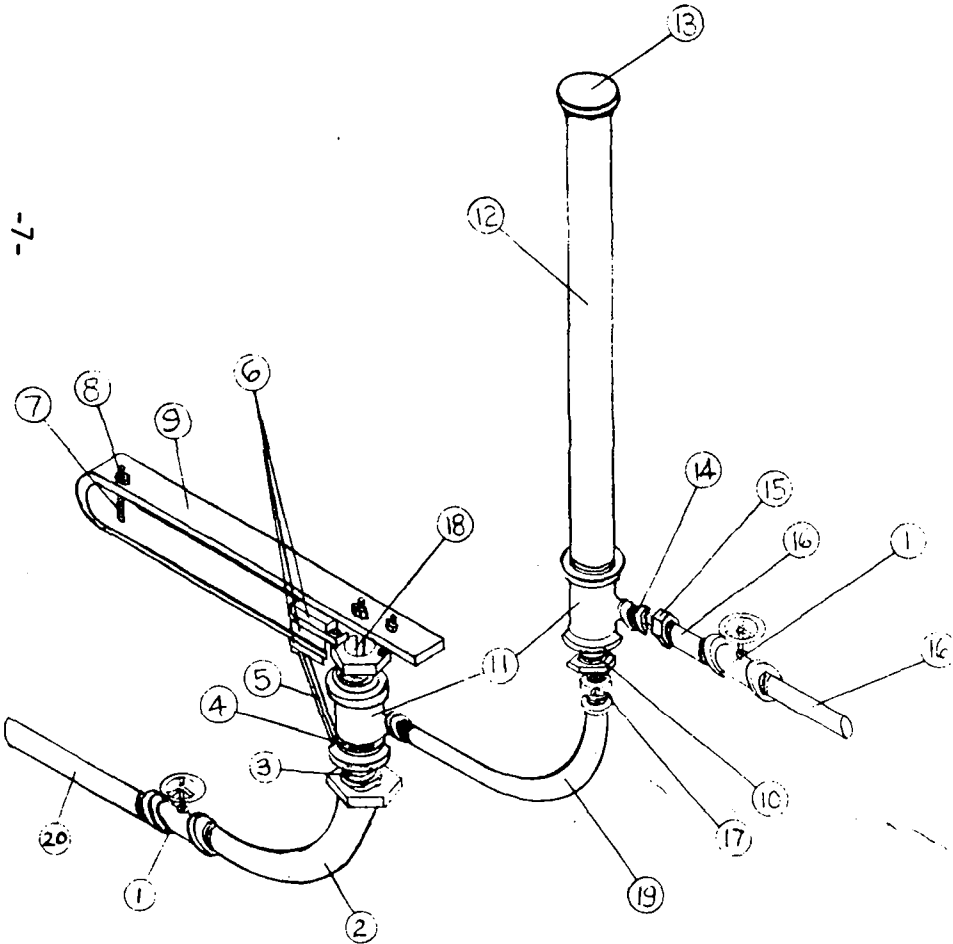

DWG. BY GRANT FULLMAN

HYDRAULIC RAM

COMPLETE ASSEMBLY

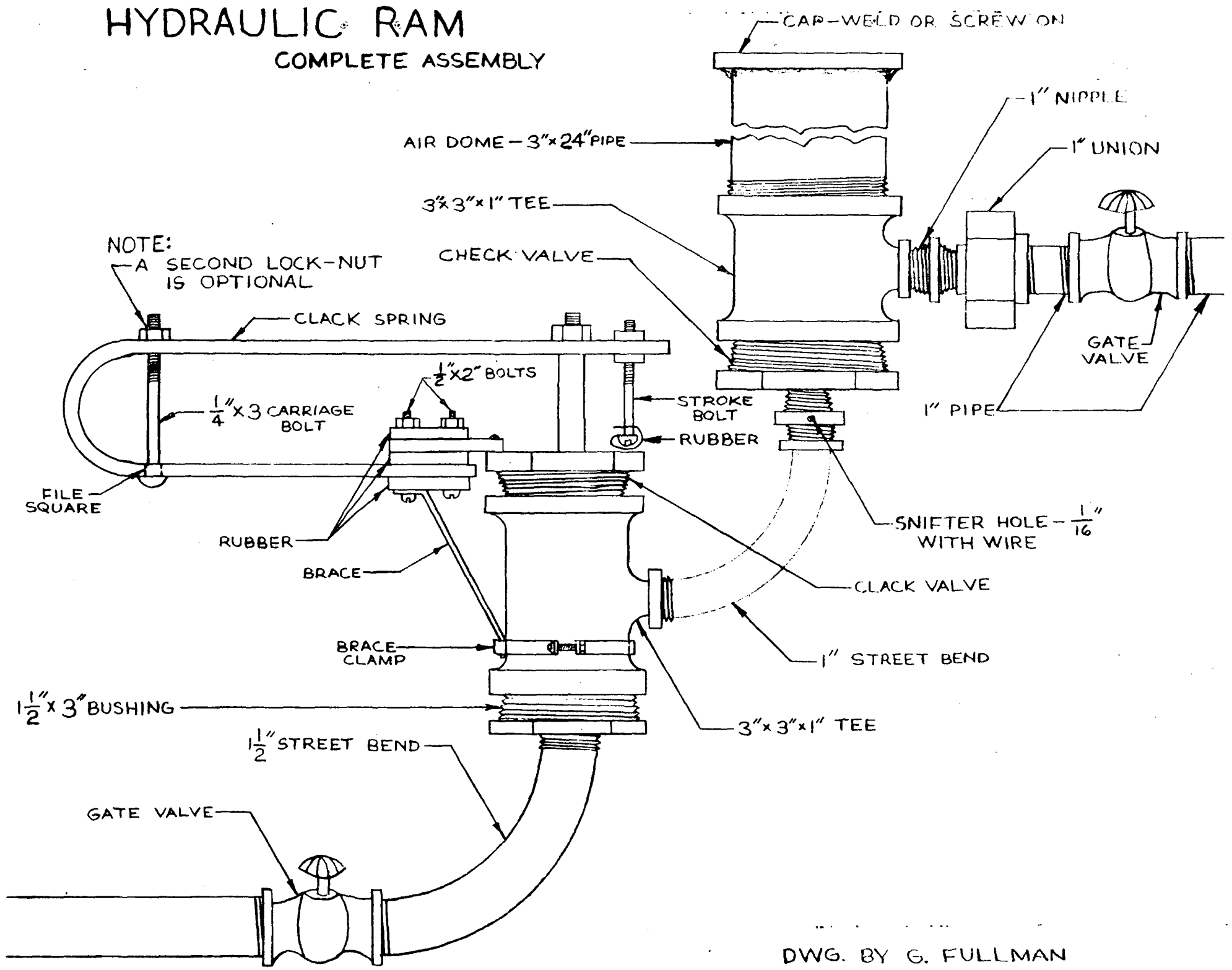

-8-

DWG. BY G. FULLMAN

HYDRAULIC RAM:
CHECK VALVE

PURPOSE OF CENTERING DEVICE:

THE CENTERING DEVICE PREVENTS THE MOVING ASSEMBLY FROM SLIPPING TO THE SIDE (OFF CENTER).

CENTERING DEVICES:

EITHER TYPE MAY BE USED:

A: PLACE PART UNDER HEAD OF BOLT AT LOCATION "A"

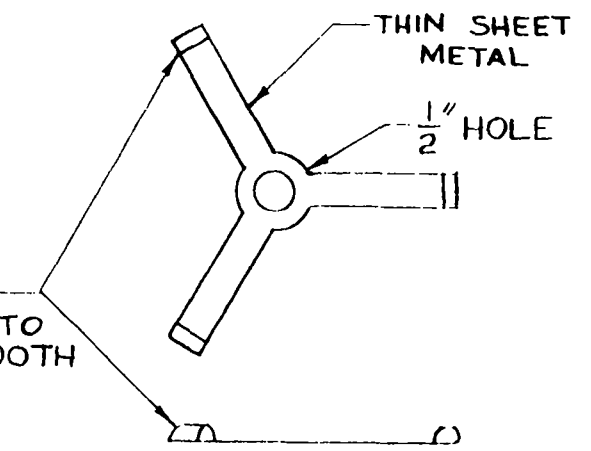

B: PLACE PART ABOVE NUT AT LOCATION "B"

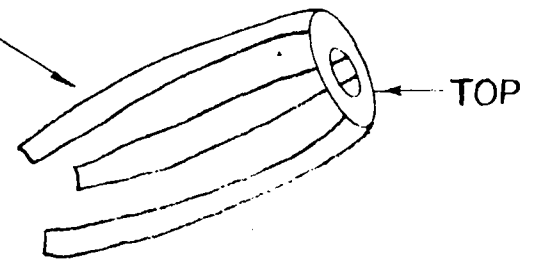

NOTE:
THIS PART IS MADE BY BENDING OVER THE ARMS OF PART "A".

DWG. BY G. FULLMAN

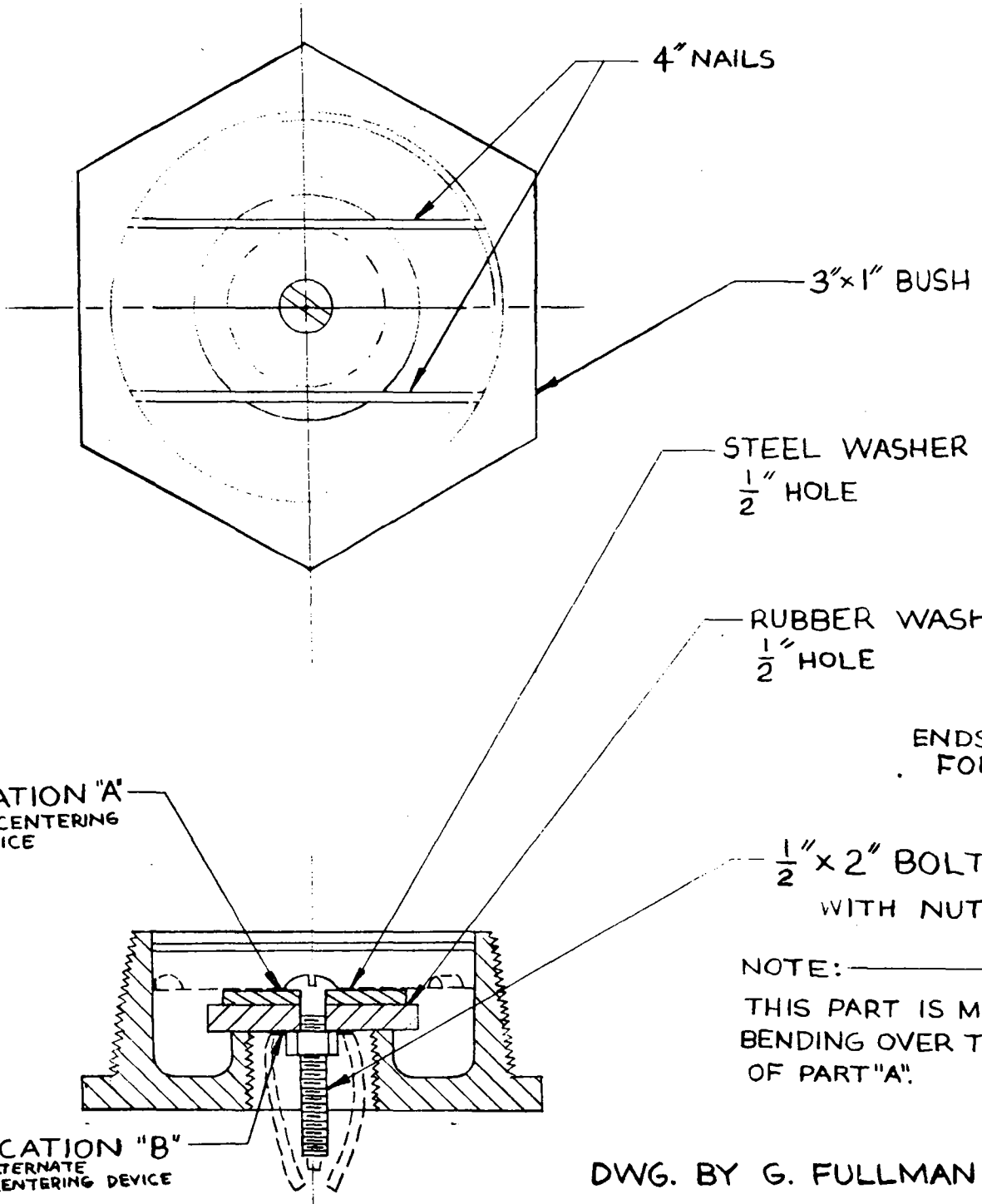

LOCATION "A"
FOR CENTERING DEVICE

LOCATION "B"
FOR ALTERNATE CENTERING DEVICE

HYDRAULIC RAM:

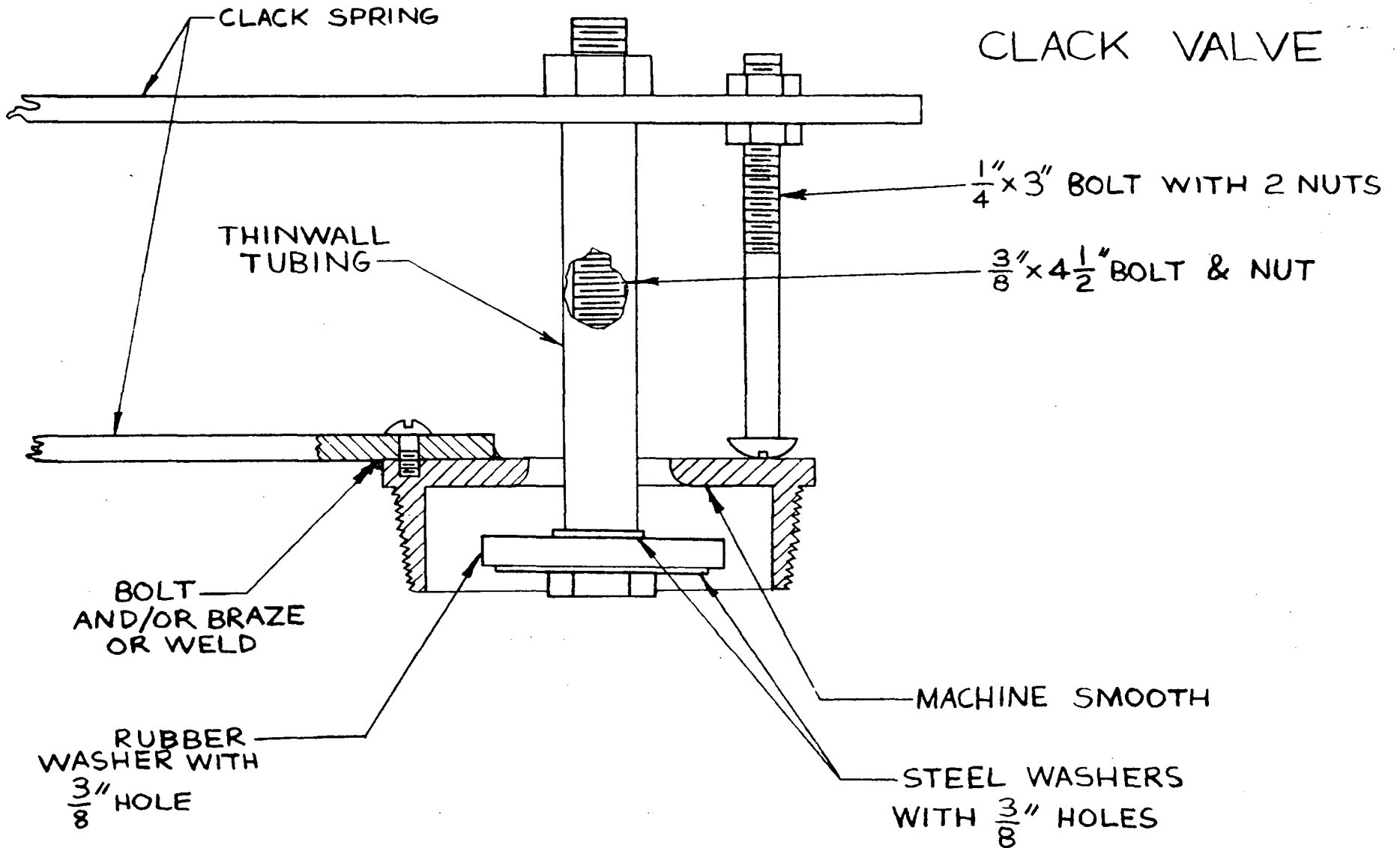

-10-

DWG. BY G. FULLMAN

PARTS LIST

QUAN.	PART
1	$1\frac{1}{2}$ " VALVE
1	$1\frac{1}{2}$ " STREET BEND
1	$1\frac{1}{2}$ " x 3" BUSHING
1	BRACE
1	BRACE CLAMP
2	3" x 3" x 1" TEES
1	$\frac{1}{4}$ " x 3" CARRIAGE BOLT & NUT (2 NUTS OPTIONAL FOR LOCK-NUT)
1	CLACK SPRING
3	RECTANGULAR PIECES OF RUBBER
2	$\frac{1}{2}$ " x 2" BOLTS WITH NUTS
1	3" x 24" PIPE
1	CAP FOR AIR DOME
2	3" x 1" BUSHINGS
1	SHEET METAL DISK ABOUT $2\frac{1}{4}$ " IN DIAMETER
1	$\frac{1}{2}$ " x 2" BOLT WITH NUT
1	STEEL WASHER, $\frac{1}{2}$ " HOLE
1	RUBBER WASHER, $1\frac{3}{4}$ " DIAMETER, $\frac{1}{2}$ " HOLE
2	4" NAILS
1	$\frac{1}{4}$ " x 3" BOLT WITH 2 NUTS
1	$\frac{3}{8}$ " x $4\frac{1}{2}$ " BOLT WITH NUT
1	$\frac{3}{4}$ " DIAMETER x ABOUT 4" LONG THINWALL TUBING
1	RUBBER WASHER, $1\frac{3}{4}$ " DIAMETER, $\frac{3}{8}$ " HOLE
1	STEEL WASHER, ABOUT $\frac{3}{4}$ " DIAMETER, $\frac{3}{8}$ " HOLE
1	STEEL WASHER, ABOUT $1\frac{1}{4}$ " DIAMETER, $\frac{3}{8}$ " HOLE
1	1" VALVE
1	1" UNION
2	1" NIPPLES
1	SMALL PIECE OF RUBBER FOR STROKE BOLT
1	1" STREET BEND
1	SHORT PIECE OF $\frac{3}{32}$ " WIRE FOR SNIFFER HOLE