

**Wavin**

LIBRARY  
INTERNATIONAL REFERENCE CENTRE  
FOR COMMUNITY WATER SUPPLY AND  
SANITATION (IRC)

2 3 2.2

8 8 WA

# Wavin direct action handpump

Instruction manual  
for installation  
and maintenance

Wavin Overseas b.v.  
Rollepaal 19  
P.O.Box 158  
7700 AD Dedemsvaart  
The Netherlands  
Phone: (0)5230-24911

232.2-88WA-4258



# Wavin direct action handpump

Instruction manual  
for installation  
and maintenance

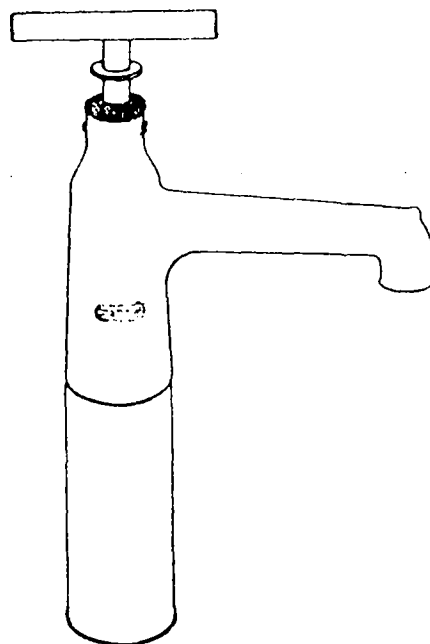

LIBRARY, INTERNATIONAL REFERENCE  
CENTRE FOR COMMUNITY WATER SUPPLY  
AND SANITATION (IRC)  
P.O. Box 93190, 2509 AD The Hague  
Tel. (070) 814911 ext. 141/142

RN: *wh 4250*  
LO: *232.2 88WA 2nd copy*







## GENERAL

The following parts are in the box:

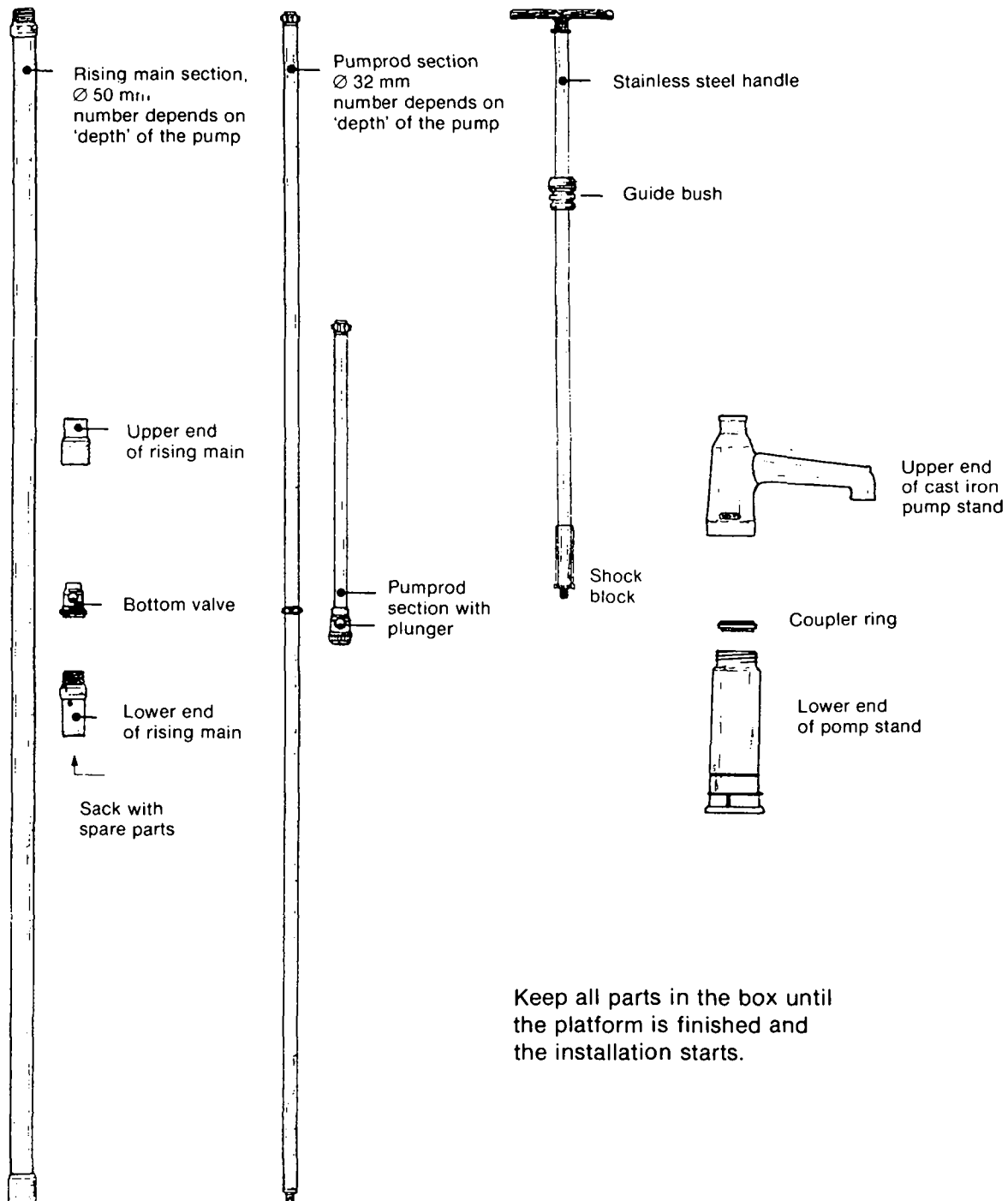

Keep all parts in the box until the platform is finished and the installation starts.

The pump is suited for casings of  $\varnothing$  75 mm or  $\varnothing$  90 mm. If other sizes are met, an appropriate reduction piece shall be applied.

## INSTALLATION

Before the actual installation of the pump can take place, a **tapping platform** has to be constructed.  
The construction should preferably be such that the final situation becomes:

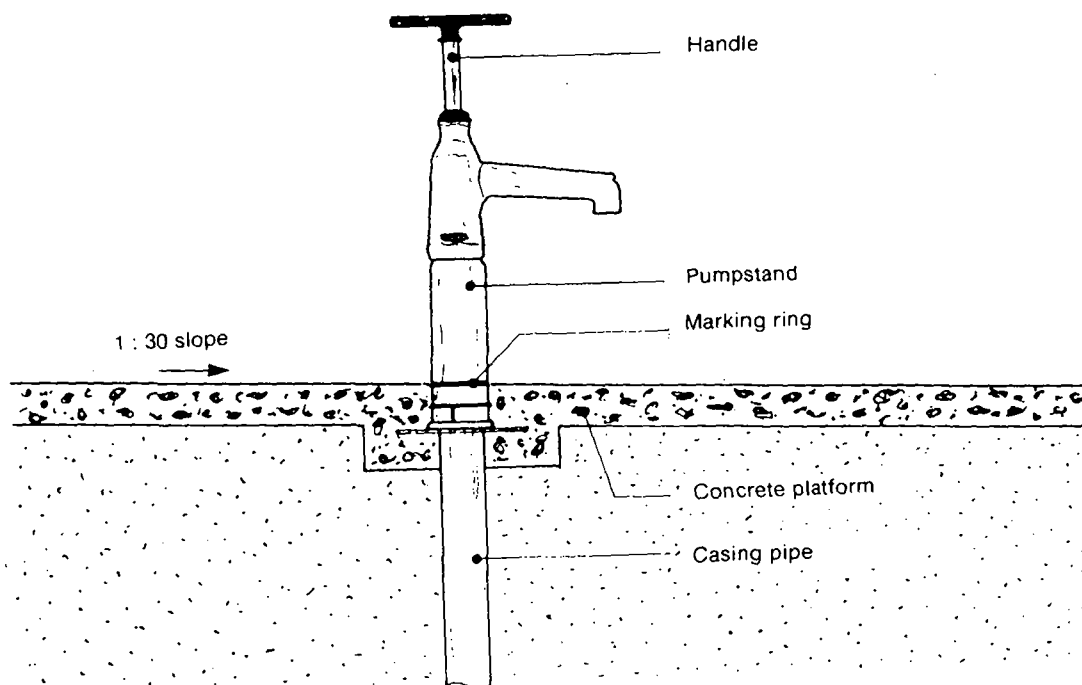

Approx. 1,5 m<sup>3</sup> of concrete should be prepared

Components: 250 l. cement  
600 l. clean sand  
900 l. clean gravel and water

**STEP 1**

Clean and flatten an area of approx. 4 x 4 metres around the casing. Remove grass, bushes, stones etc.

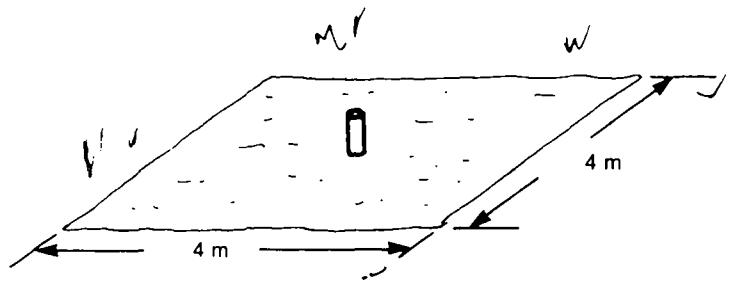
**STEP 2**

Make a decision in what direction the waste water shall flow. Add sand until a slope of 1 : 30 is reached. (The lowest side of the treated area shall not be more than 5 cm below normal surface).

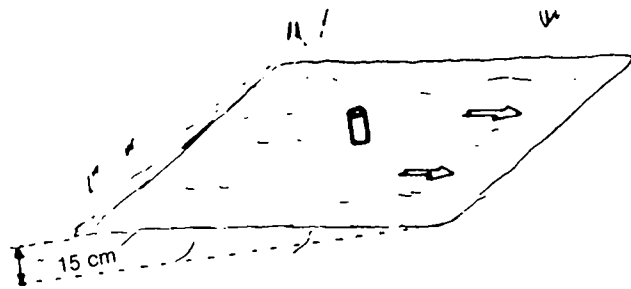
**STEP 3**

Cut the casing to the desirable height:

- when the casing is  $\varnothing$  75 mm: preferably 300 mm above the sand level (minimal 150 mm)
- when the casing is  $\varnothing$  90 mm: preferably 90 mm above the sand level (minimal 50 mm)

(a  $\varnothing$  110 mm casing requires a reducer to  $\varnothing$  90 mm)

**STEP 4**

Dig a hole of approx.  $\square$  350 mm and 75 mm deep around the casing.

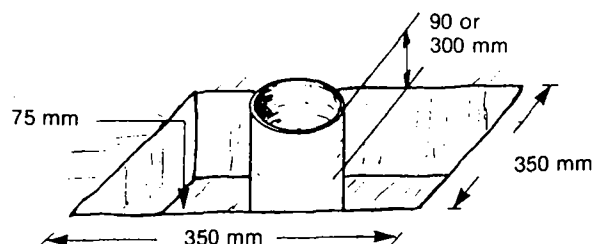

**STEP 5**

Assemble the lower piece of the pumpstand on the casing.

A vertically placed line, directly above the marking ring, indicates the direction of the spout later on.

This indicator should point downwards (with the slope), to obtain a proper discharge of waste water.

The interior of the pumpstand contains stop-shoulders for a  $\varnothing 75$  mm casing and for a  $\varnothing 90$  mm casing.

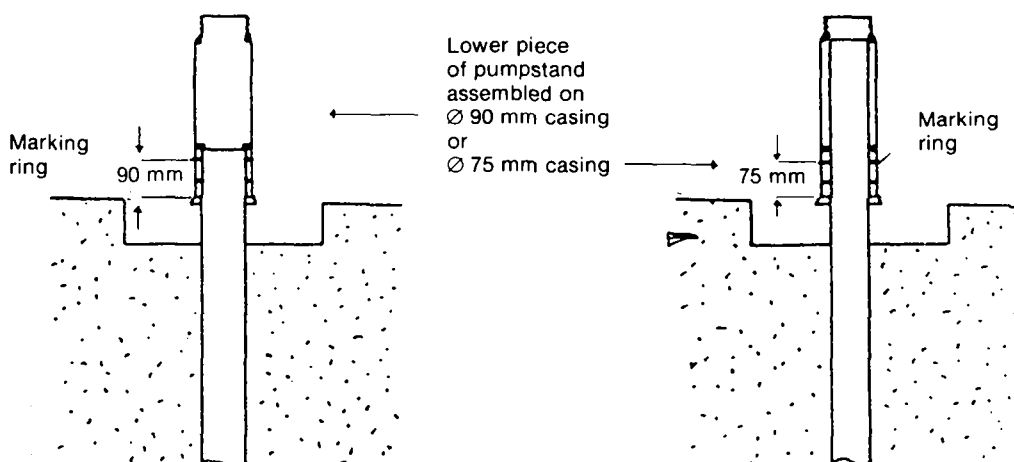
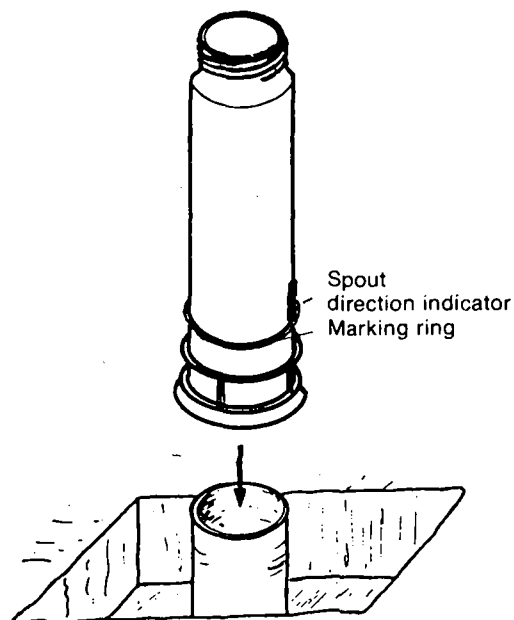

The marking-ring of the pumpstand should be approx. 75 mm above the sandlevel - approx. 150 mm above the bottom of the hole.

**STEP 6**

Fill up the hole with concrete.

The concrete should be reinforced around the pumpstand with iron wire.

A  $\varnothing 6$  mm or  $\varnothing 8$  mm wire, bend to a square of approx.  $\square 250$  mm placed  $\pm 25$  mm higher, is ideal.

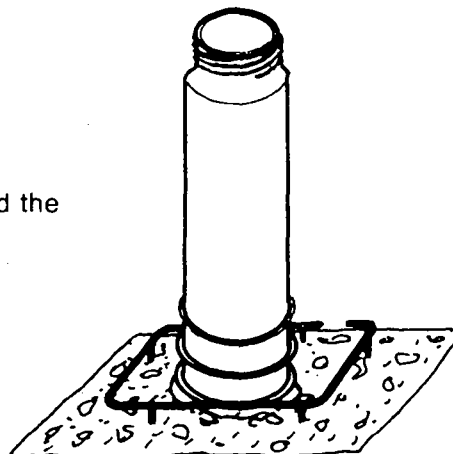



**STEP 7**

Surround the area to be covered with concrete, with a brick or earth wall and pour the concrete in. The prepared slope should be kept in tact.

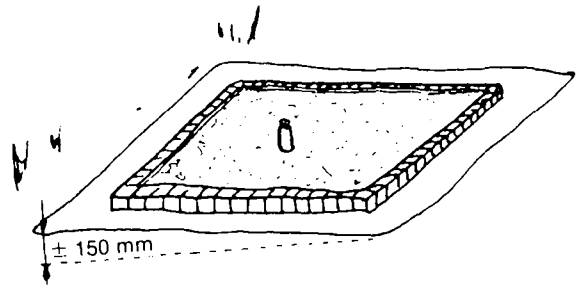

The concrete should be poured in up to the marking ring on the pumpstand. A concrete plate of approx. 75 mm is thus obtained.

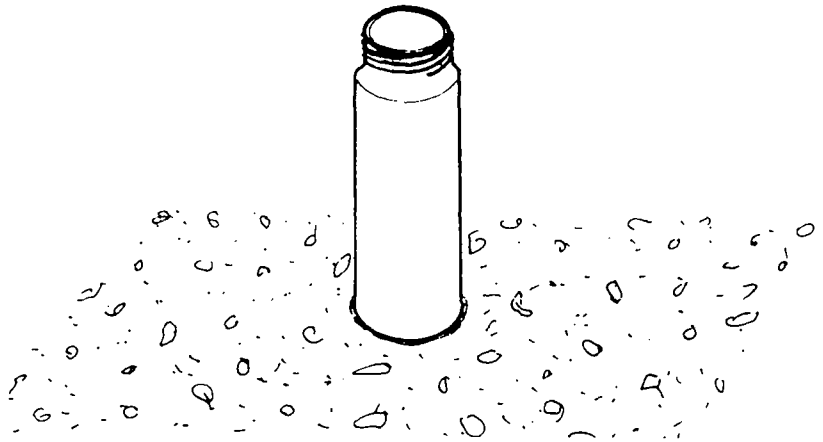
**STEP 8**

The next day the waste water channel shall be made. Provide a small gutter in the middle (use bricks and concrete mortar).

Protect the platform against damaging. Let it rest for approximately 8 days.

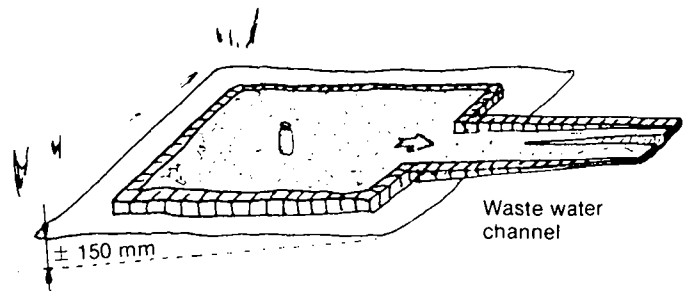

The actual **installation of the pump** can now take place.

### STEP 9

Assemble: - lower end of rising main (water inlet)  
 - bottom valve with ball inside and o-ring outside  
 - one or two rising main pieces (2½ m)

In the box, the valve is fitted in between the upper end and the lower end of the rising main.

The upper end shall be removed and replaced by a 2½ m drop pipe piece.

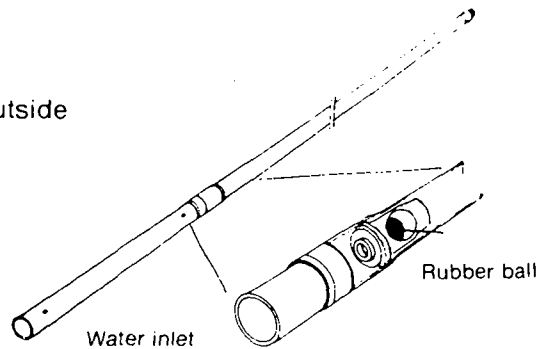

Note: Leave the sack with spare parts where it is.

### STEP 10

Assemble: - A (2½ m) rising main piece  
 - coupler ring (grey) with rubbering  
 - upper end of rising main

The coupler ring should be placed with the rubber ring around it (top end) (Later on the ring will be clamped in between the casing reducer and the pump stand).

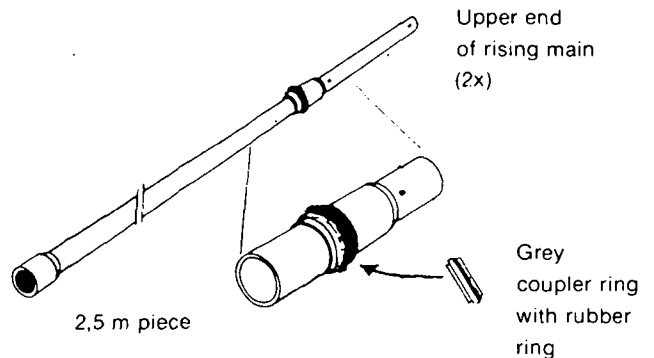

### STEP 11

Lower the rising main pieces in the casing one by one after connecting the piece to the previous one.  
 Start with the assembly from action 10 and end with the assembly from action 11.

The rising main is installed now.  
 (It hangs on the lower end of the pumpstand at the coupler ring).

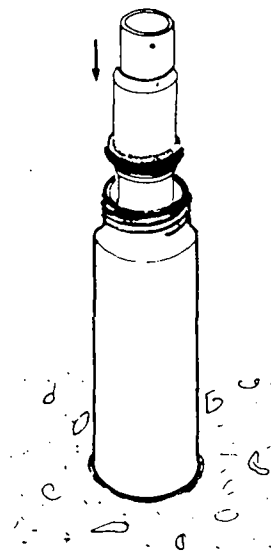

**STEP 12**

Screw the upper end of the pumpstand in the lower end. Use the spout as a grip; do not use other tools. When screwed in, the spout points down with the platform slope. Loosen the two screws at the top of the upper end.

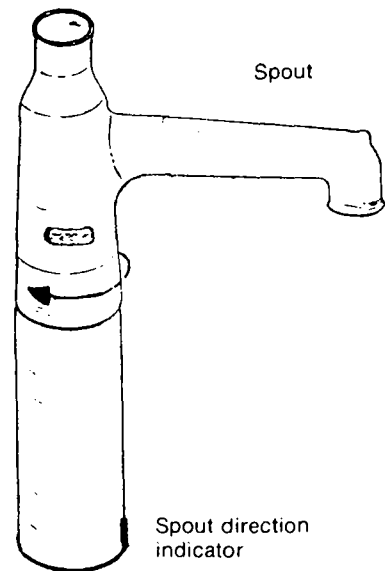
**STEP 13**

Connect the pump rod piece supplied with the plunger to another (2½ m) piece. Lock the connection by lock clip. Push these carefully in the rising main. The sealing shall not be damaged. (If necessary, press the sealing firmly in its groove; within some hours it will expand again).

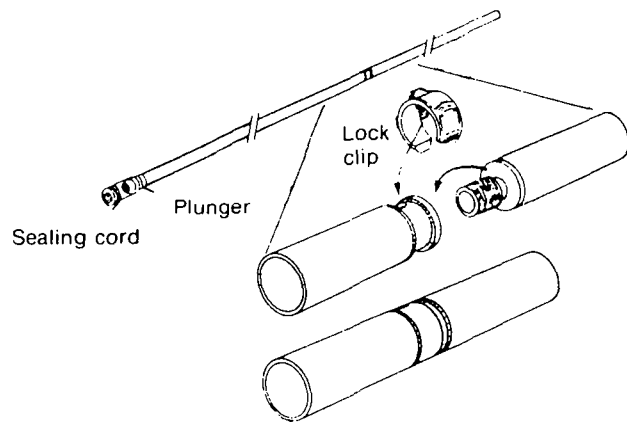
**STEP 14**

Lower all pump rod pieces, connecting to the previous one using lock clip. The short (0.45 m) section should be included. (The purpose of this section is explained in the following chapter on maintenance).

**STEP 15**

The handle, with the (black) guide bush already on it, has to be connected to the last pumprod piece (again by lockpin), after which is lowered also. Use the handle to press the guide bush in the pumpstand and lock it with the two screws.

**The pump is ready now**

Pump approximately 100 strokes. Let the water flow away. After this the water can be used.

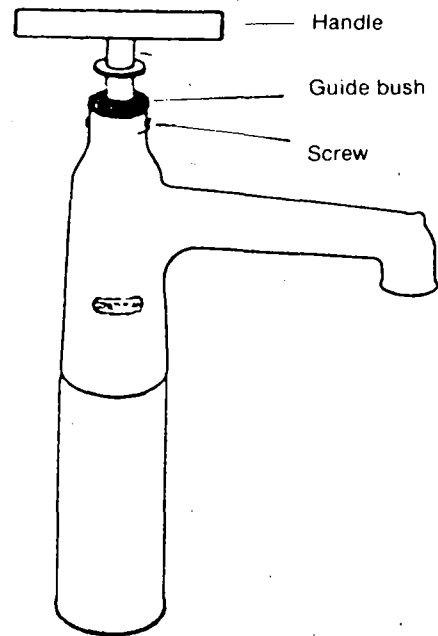

## MAINTENANCE

Please find below remedies when your pump does not perform adequately.

### I. Discharge is decreasing

Take off the top bush of the pumpstand and lift the pumprod (+ plunger).

- a. It is possible that the **plunger** contains **dirt** underneath the ball. If so, remove the ball lock ring (a plastic spring), remove the ball, clean the seat and re-assemble again.
- b. It is also possible that the rameh **sealing cord** of het plunger is "**worn-out**" (too much bedded in its groove). Proper re-functioning can often be achieved by just taking out the cords and by remounting them again. If necessary also new cords can be mounted.  
The spare-bag in the water-inlet (the bottom part of the rising main) contains new ones. With the mounting of the cords, the splits of the two should not be in line (see sketch).

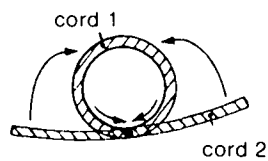

If the above does not solve your problem, unscrew the pumpstand and lift the rising main. Unscrew the bottom piece (the water inlet) and take out the foot valve.

- c. As with the plunger the **foot valve** can contain **dirt** under the ball. (Same procedure as with 1a).
- d. A last possibility is the occurrence of **scratches on the cylinder wall**, the part of the rising main in which the plunger is moved. This problem can be solved by exchanging rising main section. If the pump in question is a 12 m - depth pump, 4 rising main sections can be exchanged. Likewise with a 17 m-depth pump, 6 sections; etc.  
The number of possibilities can be doubled by turning the complete rising main upside down. Another doubling of possibilities is achieved by taking out the 1/4 (0.6 m) pumprod section. Consequently, the pump contains numerous cylinders. By the way, every cylinder has average service life of about 2 years.

### II. Discharge during half of the stroke only.

- a. When the pump has discharge in **the downward stroke** only, the **plunger-ball** is not in its seat. Take off the pumpstand-bush, lift the pumprod + plunger and make sure that the ball can function properly again.
- b. When the pump has discharge in **the upward stroke** only, the **footvalve-ball** is not in its seat. After having lifted the pumprod, unscrew the pumpstand, lift the rising main and treat the footvalve.

### III. The waterlevel in the pump drops.

The **footvalve** does not operate adequately. Take off the pumpstand bush. Lift the pumprod, unscrew the pumpstand and lift the rising main to get to the foot-valve.

- a. It is possible that there is dirt on the **ball-seat**. If so, remove the ball lock ring (a plastic spring), remove the ball and clean the seat.
- b. It is also possible that the leakage occurs around the foot valve. This can occur when the rubber o-ring is not on its place. Demount the ring and replace it. When required a new ring can be found in the spare bag (in the water inlet).

### IV. No discharge at all.

The footvalve is blocked. It should be taken out (see III).

- a. Most probably the ball is locked in its seat. This can occur when the ball is worn-off considerably. Replace the ball by a new one from the spare bag.

### V. Leakage at the guide bush

When the rubber seals in the guide bush are worn out they can be replaced by new ones which you will find in the bag with spares.

- a. Loosen the two screws in the upper end of the pumpstand.
- b. Pull out the handle and guide bush.
- c. Remove the lockclip from the pumprod coupler.
- d. Unscrew the handle from the pumprod.
- e. Place the handle in upright position on a solid flat surface.
- f. Now, hammer the guide bush firmly on the shock pipe, the grey ring will spring loose, and the guide bush can be removed.
- g. Take out the worn out seal(s) with a screw-driver, noticing which type of seal is put at the top and which one is put at the lower end of the guide bush.
- h. Replacement of seals should be done very carefully.
- i. Everything can be reassembled now, the grey ring can be pushed in its position, by screwing the handle on the pumprod.

### NOTES:

- Lifting the pumprod should be done in sections. When taking it apart in sections, the lock clips at the couplers have to be removed temporarily. Put them back on the coupler half directly after unscrewing. When lowering the pumprod the lock clips should be mounted again (to avoid unscrewing during operation).
- The Wavin handpump does not require any tools except a screwdriver to loosen the top bush. Do not use any tools for other action(!) It can only cause problems.