

**ECONOMIC AND SOCIAL COMMISSION FOR ASIA AND THE PACIFIC**

232.4 9150

**SOLAR-POWERED WATER PUMPING  
IN ASIA AND THE PACIFIC**



**UNITED NATIONS**

232-4-9150-9431

ECONOMIC AND SOCIAL COMMISSION FOR ASIA AND THE PACIFIC

# SOLAR-POWERED WATER PUMPING IN ASIA AND THE PACIFIC

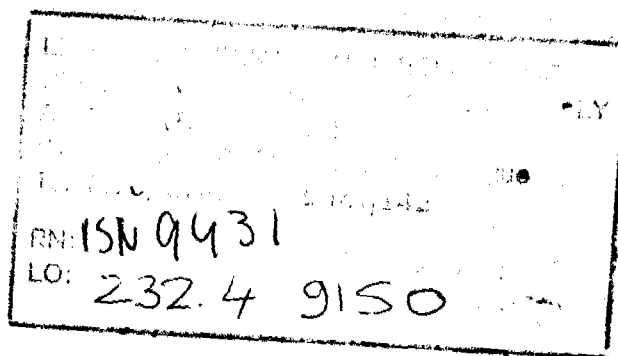

UNITED NATIONS

New York, 1991

**ST/ESCAP/1063**

The designations employed and the presentation of the material in this publication do not imply the expression of any opinion whatsoever on the part of the Secretariat of the United Nations concerning the legal status of any country, territory, city or area, or of its authorities, or concerning the delimitation of its frontiers or boundaries.

The mention of any firm or licensed process does not imply endorsement by the United Nations. This publication has been issued without formal editing.

## FOREWORD

Solar-powered water pumping is one of the most attractive applications for solar energy which is mostly available in the very areas and at the very times when the needs for water are greatest.

Hundreds of solar photovoltaic pumps have been built and operated in countries of Asia and the Pacific. Hence, their technical feasibility has been proven and the photovoltaic solar pumping technology is now a mature and reliable technology.

Although the present costs of solar pumping systems are high, they are comparable to the costs of fuel-powered systems in remote areas and islands for the provision of drinking and domestic water supplies. Considering the reduction of the cost of photovoltaic arrays, this promising technology will become economically viable even for small-scale irrigation in areas with adequate irradiation.

Prospects for the application of solar water pumping are high in the Asian and Pacific region where millions of water pumps are required for drinking water supply and irrigation. The suitability of the climate, with high solar radiation rates all the year round in most parts of the region, suggests that a significant number of these pumps could be powered by solar energy.

However, one of the main obstacles at present to the wider dissemination of solar water pumps in the developing countries of the region is general unfamiliarity of technical and managerial personnel engaged in water resources development with the technology. Therefore, in response to the need of these countries of the region for such familiarization, this study has been prepared under the auspices of ESCAP with a view to promoting solar-powered water pumping for the benefit of developing countries.

This publication was prepared for the ESCAP secretariat by Professor R.H.B. Exell, of the Asian Institute of Technology, Bangkok.

## CONTENTS

	<i>Page</i>
Foreword .....	(i)
Introduction .....	1

### **PART ONE SOLAR ENERGY FOR WATER PUMPING**

A. Solar water pumping .....	5
B. The solar resource .....	9
C. Solar pumping technology .....	15
D. Design of a PV solar pumping system .....	21
E. Economics of solar pumping .....	24
F. Environmental impacts of solar pumping .....	29
G. Social aspects of solar pumping .....	30
H. Advantages and disadvantages of solar pumping .....	33

### **PART TWO APPLICATION OF SOLAR PUMPING**

A. Solar pumping in regions other than ESCAP .....	37
B. Questionnaire survey on solar pumping in the ESCAP region .....	39
C. Notes on selected countries in the ESCAP region .....	43
D. International cooperation through ESCAP in the promotion of solar pumping .....	48

### **PART THREE CONCLUSIONS AND RECOMMENDATIONS**

A. Conclusions .....	53
B. Recommendations .....	54
Bibliography .....	55

## LIST OF TABLES

		<i>Page</i>
Table 1.	Spectral distribution of extraterrestrial solar radiation .....	9
Table 2.	Approximate economic feasibility ranges for water pumping technologies .....	24
Table 3.	Cost comparison of a diesel pump, wind pump and solar pump for a particular location .....	26
Table 4.	Projected costs of solar pumps.....	28
Table 5.	Utilization of solar water pumping in Asia and the Pacific.....	39
Table 6.	Purposes for which solar water pumping might be considered in Asia and the Pacific .....	39
Table 7.	Country concerns in establishing solar water pumping in Asia and the Pacific .....	41
Table 8.	Country requirements for assistance in promoting solar water pumping in Asia and the Pacific .....	42

## LIST OF FIGURES

Figure I.	Solar photovoltaic water pumping system .....	5
Figure II.	Water flow rate from solar pump versus time of day in clear weather .....	5
Figure III.	Variation of monthly and daily solar irradiation .....	6
Figure IV.	Chart for selecting a pumping system .....	8
Figure V.	Solar-powered Rankine engine operated water pump .....	15
Figure VI.	Principal configurations of solar pumps .....	18
Figure VII.	PV system with DC-AC inverter .....	19
Figure VIII.	PV pump performances with irradiation 6 kWh/m <sup>2</sup> per day .....	20
Figure IX.	Simple oscillation pump operated by hand or by PV array .....	20
Figure X.	Approximate sizing of PV pumping system .....	22
Figure XI.	Friction head in smooth pipes of different internal diameter .....	22
Figure XII.	Solar pump and diesel pump cost comparison .....	25
Figure XIII.	Water supply system for a village in Thailand .....	31
Figure XIV.	Integrated rural energy centre in Sri Lanka .....	47

## LIST OF MAPS

	<i>Page</i>
Map 1. Mean daily global solar irradiance in the ESCAP region in March .....	10
Map 2. Mean daily global solar irradiance in the ESCAP region in June .....	11
Map 3. Mean daily global solar irradiance in the ESCAP region in September .....	12
Map 4. Mean daily global solar irradiance in the ESCAP region in December .....	13
Map 5. Principal solar radiation climates according to Terjung .....	14

## INTRODUCTION

Approximately half of the population of the world, that is 2.5 billion persons, live in rural areas in developing countries. However, their share of conventional energy sources such as coal, gas or oil is very limited. Sources of energy commonly used for rural water pumping are human or animal power, electricity and oil. Although diesel- and electric-powered pumps appear to be much more attractive, the high cost, the difficulties in securing regular fuel supplies in many areas, and the high level of expertise required for operation and maintenance may limit their application.

Since the sharp oil price rises of the early 1970s, renewable energy sources have become a significant component of many rural development activities. In these areas, pump operation using renewable sources of energy is becoming popular. World-wide, more than 20,000 solar pumps have been installed. Most of them are small systems for remote homes and communities. The volume of water pumped by solar-powered pumps still constitutes, however, a very small fraction of the total even though some systems cost little more than their fuel-powered equivalents. General unfamiliarity with the technology is, perhaps, the main barrier at present to the wider use of solar pumps.

Realizing the potential for the application of renewable sources of energy, ESCAP has organized a number of expert group meetings. The meeting of the Expert Working Group on the Use of Solar and Wind Energy, held at Bangkok in March 1976, concluded *inter alia* that research and development were needed to develop economic prototype solar pumping systems.

UNDP initiated a project in 1978, executed by the World Bank, with the objective of assessing available solar pumping technology in order to consider whether to promote its development to provide water for irrigation in rural areas under the prevailing conditions. The project concluded that while the technology had potential, further technical development was necessary to produce more reliable, robust and efficient systems at lower costs.

In the meantime, in 1981 ESCAP prepared a catalogue of experts, institutions and projects in the region and a bibliography of material related to solar energy.

The first project was followed up by UNDP as the second phase under its project executed by the World Bank, which produced the report *Small-scale Solar-powered Pumping Systems: the Technology, its Economics and Advancement* in June 1983. In that phase, water supply applications and pumping water for irrigation were considered. Different sizes and brands of pumps were tested and found to be technically superior to those tried in the first project. There were prospects for higher efficiency, and costs were lower. As a result of this project, *Solar Water Pumping: A Handbook* was published in 1984.

In response to the Nairobi Programme of Action for the Development and Utilization of New and Renewable Sources of Energy, ESCAP, with funds from Japan, initiated a five-year project in 1983, and established a computerized biomass-solar-wind energy information network. At its conclusion in 1988, in addition to the provision of advisory services to the member countries for five years, the project also produced the *Solar Photovoltaic Handbook* and *Computer Package Manual* for the application of photovoltaic systems in rural areas.

The present report is an evaluation of the potential applications of solar energy technology for water pumping in the developing countries of the ESCAP region. It contains a review of solar pump technology, including solar water pump design and economics, and a review of the application of solar energy to water pumping world-wide, with special emphasis on the ESCAP region. Conclusions are drawn on the applicability of existing solar pumping technologies for the particular conditions of the developing countries, and recommendations are made on the use of solar energy for water pumping in the region.

It is hoped that this report will encourage actual or potential users of water pumping systems to consider solar energy as a feasible alternative source of power for operating the pumps, and to dispel any fears that solar pumping is too difficult to understand, or perpetually out of reach because of its cost. No only is the technology easily understood; it is also becoming financially attractive in certain circumstances as the prices of solar pumping systems gradually come down.



# **Part One**

## **SOLAR ENERGY FOR WATER PUMPING**

## A. Solar water pumping

At the present time solar pumps are most cost-effective for applications with low power requirements (200 W-5 kW) in remote places. They are therefore well suited in developing countries to rural village applications. These applications include:

- Domestic water supplies
- Livestock water supplies
- Irrigation

Solar energy must be viewed as one of several possible energy sources for operating pumps. These include conventional sources of energy such as:

- Hand pumping
- Grid electricity
- Diesel fuel

and renewable sources of energy such as:

- Wind
- Solar energy
- Biomass.

Village water supplies for domestic use and livestock are characterized by a relatively constant daily demand throughout the year. When a variable renewable source of energy is used, such as wind or solar energy, it is important to have a storage tank to provide water in periods of calm or cloudy weather when the pumping rate

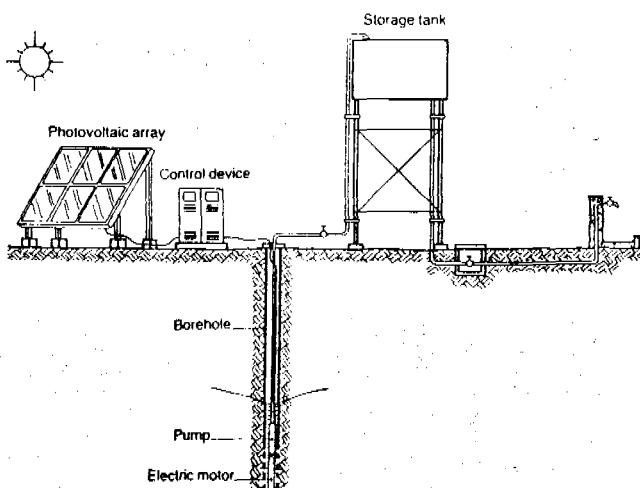

Figure I. Solar photovoltaic water-pumping system

Source: Hofkes, E.H. and J.T. Visscher, 1986.

is low. Furthermore, the water must be clean, so it is safer to pump the water from closed boreholes than from surface water in rivers or lakes. Figure I shows a typical village water supply system powered by a solar pump.

Hourly, daily and monthly variations in solar irradiation cause the output of a solar pump to vary. These variations are governed by latitude and climate, which, for developing countries in the ESCAP region, are predominantly tropical. The diurnal variation of solar irradiation is such that a solar pump will normally start at about 8 a.m., have its maximum output at noon, and stop pumping at about 4 p.m. (figure II) Moreover, the total daily output will vary from day to day because the total solar irradiation varies from day to day over a wide range (figure III). The monthly average daily total irradiation, on the other hand, does not vary greatly in the tropics.

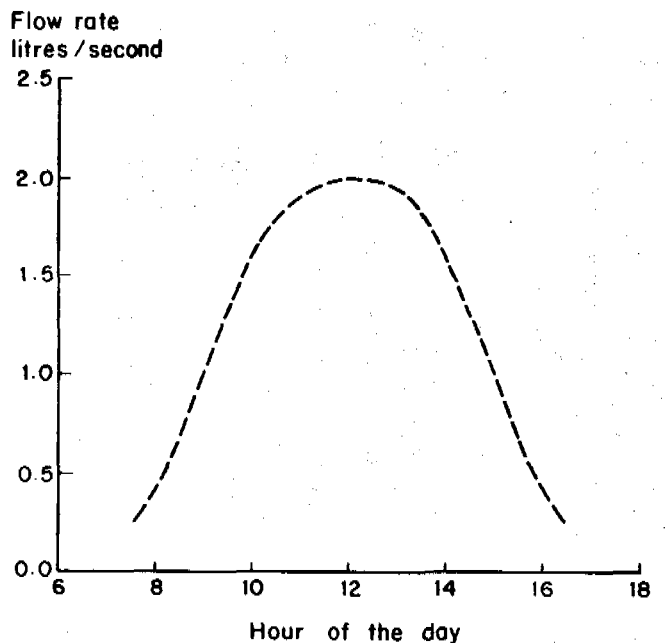

Figure II. Water flow rate from solar pump versus time of day in clear weather

Source: Kenna, J. and B. Gillett, 1985.

The water storage tank used for village water supply systems should have a capacity for about three days, since in tropical climates periods of clear and cloudy weather alternate fairly rapidly, and periods of more than two or three consecutive dull days are very rare. The size of the storage tank required to guarantee the supply of water at a given level of confidence may be calculated from detailed solar radiation data for the site. For

example, a storage of three days' supply may be enough to guarantee a continuous supply of water at a 90 per cent level of confidence. Short-term storage of a few days for use in irrigation helps to improve water management by smoothing out day-to-day variations. Long-term storage of pumped water in one month for irrigation use in any other month is not usually feasible with solar pumping.

The demand for irrigation water varies greatly from month to month. Solar pumping has the advantage that output is greatest in clear dry weather when the crop water demand is highest. Because the most water is pumped in the middle of the day when evaporation is greatest, care may be needed in timing the distribution of the irrigation water to avoid unnecessary losses. The pumping of large volumes of water to grow rice will not usually be feasible with solar systems. Solar pumping is more suitable for trickle irrigation in fruit farming. In all forms of solar irrigation the basic principle is that the cost of the water must be less than the value of the extra crop grown with the help of the irrigation. A possible disadvantage in the use of solar pumping for irrigation is that the system may be idle in the off season when pumping is not needed.

The method of distribution of the pumped water will depend on its use. If a village water supply is to be distributed through pipes, the storage tank must be elevated to provide enough pressure for the flow. Pumping the water up into the tank consumes energy; the tank should be only as high as necessary to provide the pressure required, and its area should be large compared with its depth. If the village is small, distribution pipes may be unnecessary, the people collecting the water directly from the tank. Because there are few economies of scale in solar pumping it may be better to have several pumps in the area of the community rather than one large water source and pump with distribution over long distances, provided that the cost of drilling the extra boreholes is not too great. The distribution system for irrigation may be open channels, which have losses due to evaporation and seepage of 40-50 per cent, or trickle irrigation with losses of only 15 per cent. Sprinkler irrigation is not suitable because of the relatively high pressure needed (1-2 bar), which would consume energy to create the additional head of 10-20 m. Again, irrigation over large areas may best be done with several small pumps in different places instead of with one large pump.

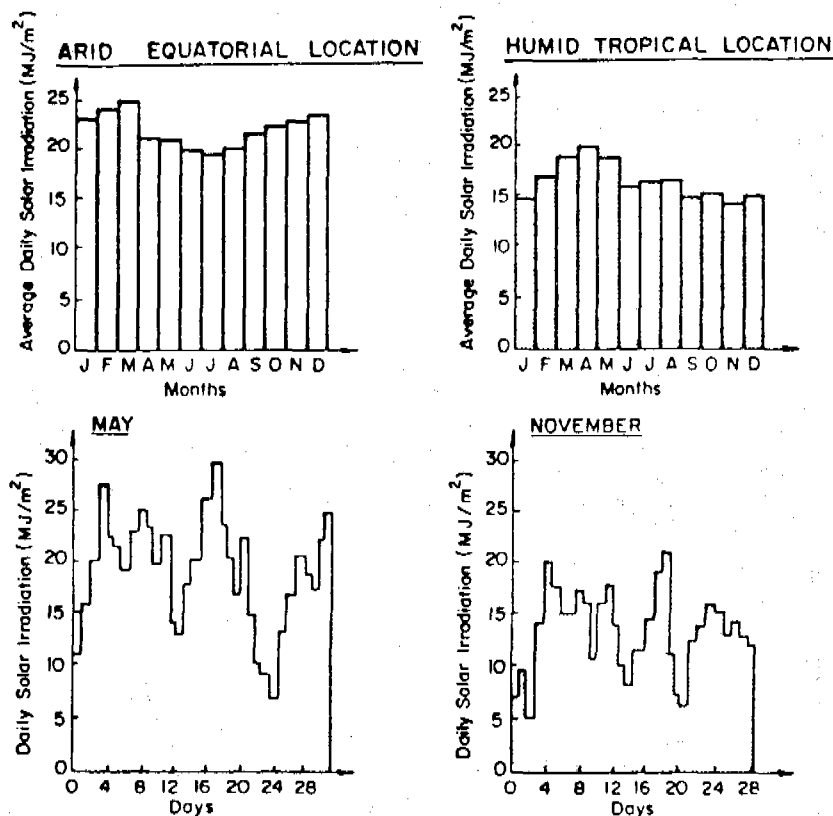

Figure III. Variation of monthly and daily solar irradiation

Source: IT Power, 1982.

Among the conventional sources of energy competing with solar energy in pumping, *human energy* for hand pumps is familiar and low cost. Hand pumps have a simple technology and are easy to maintain. However, their output is limited by the strength of the human body to about 10 m<sup>3</sup>/d from a depth of 10 m (or 5 m<sup>3</sup>/d from a depth of 20 m, etc.), and the time consumed in pumping could be used more profitably in other activities.

*Electric motors* can be used to drive pumps at locations not more than about 1 km from the main electricity grid. For satisfactory operation the power supply must not have frequent interruptions or large voltage fluctuations. There are many sites in developing countries too far from the grid for this energy source.

*Diesel engines* are commonly used to drive pumps. They have the advantage of low capital cost and portability, and they are easy to use. However, the fuel supply may be expensive and unreliable in remote places. The engines themselves are unreliable and have a short life unless they are well maintained. Diesel pumps have a rather high output (3 kW and above) for small communities, but they may be the preferred choice on economic grounds for the heavier pumping duties.

Among the renewable sources of energy, *wind power* has been used for water pumping for 2,000 years, and is still widely used. Wind pumps are very sensitive to variations in wind speed, so good wind regimes at coastal sites or in open country are necessary. The siting of the wind pump in relation to the terrain and nearby obstructions is critical. Under suitable conditions wind pumps may be preferred over solar pumps. Their capital cost is moderate; they are suitable for local manufacture; and they are easy to maintain so as to have a long life.

In comparison with pumps using other renewable energy sources, *solar pumps* have high capital cost. However, the advantages of solar photovoltaic pumps include low maintenance, reliability and long life. The technology is mature and the prices are gradually coming down, so solar PV pumping is becoming the best option for many water pumping needs today.

*Biomass waste* can be processed in digesters to produce biogas (methane), and woody solid biomass can be partially burned to make producer gas (carbon monoxide and hydrogen). These gases can be used as fuel for small engines to drive water pumps. For reasons of economic scale, biomass is only worth considering for large water pumping systems.

The *environmental feasibility* of renewable energy rests essentially on whether or not there is enough energy in the environment that can be harnessed to do the work of pumping. The criteria that can be applied are as follows:

- *Wind energy*: average annual wind speed at the site greater than 3.5 m/s, and average wind speed in the least windy month greater than 2.5 m/s.
- *Solar energy (photovoltaic)*: average annual daily solar irradiation greater than 15 MJ/m<sup>2</sup>\* (4.2 kWh/m<sup>2</sup>), and average daily solar irradiation in the least sunny month greater than 12.5 MJ/m<sup>2</sup> (3.5 kWh/m<sup>2</sup>).
- *Biomass energy*: humid climate with annual average temperature higher than 15°C, and for gasification 50-100 kg of dry wood, or crop waste from 10-20 ha per day.

The *techno-social feasibility* depends on whether or not the community possess the technical skills to operate and maintain the equipment, and whether back-up services are within reach when technical skills beyond the capability of the users are required. It is also important that the community is capable of organizing itself to manage the system without social problems. This might involve ensuring that the sharing of the water made available to the community is equitable, and ensuring that the responsibilities of certain members of the community in the operation and maintenance of the system are understood and accepted. It may also be important to avoid putting some section of the community at a disadvantage. For example, the use of biomass might consume organic waste that was previously gathered and used as domestic fuel by poor people.

The levels of technical servicing and skills needed for various alternative renewable sources of energy are as follows:

- *Commercially manufactured wind pumps*: monthly maintenance by trained mechanics, and annual back-up support by qualified technicians.
- *Village level wind pumps*: daily maintenance by villagers, and annual back-up support by local mechanics.

---

\* The Joule is the International System (SI) unit of energy. It is best expressed in millions, as MegaJoules (MJ) because this is a more practical unit. The conversion rate to the more familiar kWh is 3.6 MJ = 1 kWh.

- *Solar photovoltaic pumps:* monthly maintenance and annual back-up support, both by qualified technicians.
- *Biomass systems:* daily maintenance by well trained personnel, and monthly back-up by qualified technicians.

Conventional energy systems (diesel and electric pumps) need weekly or monthly maintenance by local mechanics, and back-up support several times a year by qualified technicians.

The local selection of a pumping system should be done taking into consideration (a) the available water supply, (b) the amount of renewable energy in the environment, and (c) the level of technical skills available to the community. Diagrams have been drawn to illustrate the logic of possible selection processes. Figure IV is one of them. If the decision process is followed step by step through the various options in accordance with the existing local situation, the outcome is likely to be a selection that is economically feasible.

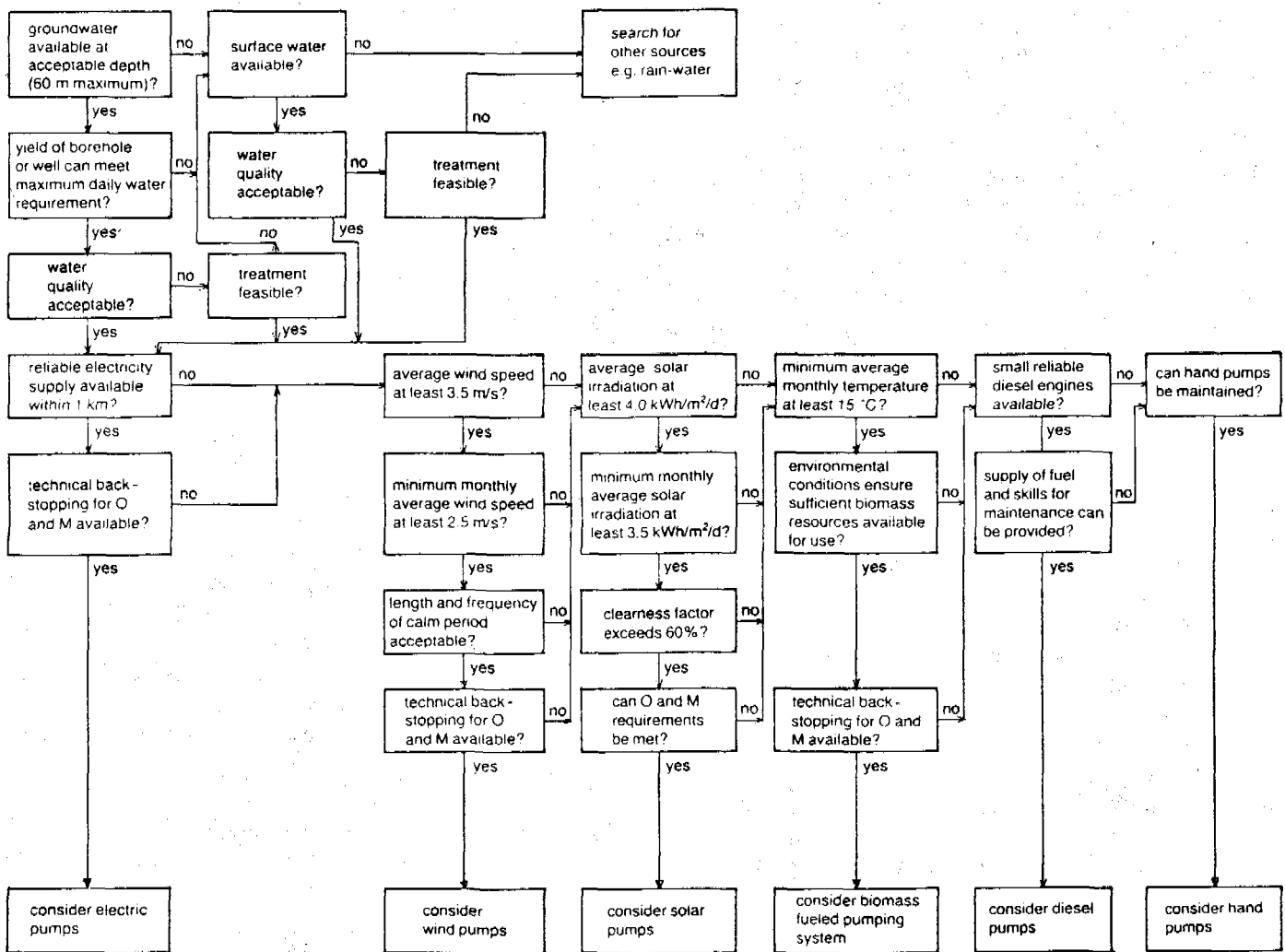

Figure IV. Chart for selecting a pumping system

Source: Hofkes, E.H. and J.T. Visscher, 1986.

## B. The solar resource

The extraterrestrial flux density of solar radiation falling on a surface perpendicular to the beam is  $1.35 \text{ kW/m}^2$ , but at the surface of the earth this radiation is altered in several different ways. The rotation of the earth and the inclination of the earth's axis produce regular, and easily calculated, diurnal and seasonal variations of solar radiation on the surface which depend on the geographical latitude of the point of observation. Scattering, absorption and reflection by the atmosphere and clouds reduce the solar radiation and divide it into direct and diffuse components.

The maximum flux of direct solar radiation in bright sunlight at the earth's surface on a panel perpendicular to the beam is about  $0.9 \text{ kW/m}^2$ . The flux of diffuse solar radiation depends greatly on weather conditions: under a clear sky it is typically  $0.1 \text{ kW/m}^2$ , but under cloudy skies it may vary from  $0.3 \text{ kW/m}^2$  to  $0.6 \text{ kW/m}^2$ . The total irradiance (direct plus diffuse) in bright sunlight of  $1.0 \text{ kW/m}^2$  is used as a standard "peak" value in rating photovoltaic arrays.

The spectral distribution of solar radiation is summarized in table 1. Solar thermal devices can utilize the whole of the spectrum listed in the table, whereas PV devices utilize only the ultra-violet and visible radiation.

**Table 1 Spectral distribution of extraterrestrial solar radiation**

Wavelength interval	Description	Energy in interval
0.3-0.4 $\mu\text{m}$	ultra-violet	8%
0.4-0.8 $\mu\text{m}$	visible	47%
0.8-3.0 $\mu\text{m}$	near infra-red	42%

The solar panels used in water pumping systems are fixed in position. In order to maximize the mean daily solar flux received throughout the year the panels are normally tilted so as to face the point in the sky where the celestial equator crosses the meridian. Meteorological tables, however, give values of solar radiation on a horizontal surface, and the radiation on tilted panels is normally greater than the radiation given in meteorological tables. The change in daily total radiation

obtained by tilting the panel depends on geographical latitude, time of the year, and cloudiness. For example, in New Delhi ( $29^\circ \text{ N}$ ) the effect of tilting the panel is to increase the mean daily solar radiation on the panel by about one-third during the winter when skies are clear; but in the summer when skies are frequently cloudy the effect of tilt is small.

In equatorial regions the daily global solar radiation on a horizontal surface is typically  $18 \text{ MJ/m}^2$ , but in places with heavy rainfall it may be as little as  $14 \text{ MJ/m}^2$ . Because local convection is the main cause of cloud (and rain), the daily radiation fluctuates over the wide range  $5\text{-}25 \text{ MJ/m}^2$  and overcast periods more than one or two days long are rare.

Latitudes  $10\text{-}20^\circ \text{ N}$  or  $\text{S}$  have wet cloudy summers similar to equatorial climates, and dry clear winters similar to desert climates. Daily solar radiation in the dry winters is typically  $20 \text{ MJ/m}^2$ , but is fairly constant, fluctuating over the narrow range  $15\text{-}25 \text{ MJ/m}^2$ .

At subtropical latitudes  $20\text{-}30^\circ \text{ N}$  or  $\text{S}$  clear skies dominate the desert climate of Southwest Asia, while East Asia has more cloud. The daily global solar radiation in the desert climate is typically  $28 \text{ MJ/m}^2$  in summer but only  $14 \text{ MJ/m}^2$  in winter due to the low sun. In East Asia the daily radiation is typically  $20 \text{ MJ/m}^2$  in summer, and  $10 \text{ MJ/m}^2$  in winter. Tilting the solar panels will offset the reducing effect of the lower altitude of the sun in winter.

Variations in the terrain, especially the presence of coastlines and mountains, can produce large differences in climate over distances of the order  $100 \text{ km}$ . Over distances less than  $10 \text{ km}$ , however, differences in solar radiation are small. Consequently, the selection of sites for the exposure of solar panels is not critical at the local level, apart from the obvious requirement that the panels are never shaded by nearby obstructions.

The broad outlines of the daily global solar irradiance in the ESCAP region, omitting local details, can be obtained from map 1 to map 4 for the four principal seasons (March, June, September and December). Map 5 shows the principal solar radiation climates according to Terjung. Climate types B, C and D have maximum mean daily irradiation greater than  $25 \text{ MJ/m}^2$ ; F, G and H have maximum mean daily irradiation  $20\text{-}25 \text{ MJ/m}^2$ ; and types K, L, M have maximum mean daily irradiation  $15\text{-}20 \text{ MJ/m}^2$ . Within these groups of high,

medium and low irradiation the subdivisions indicate how much the mean daily irradiation fluctuates between its maximum and minimum throughout the year. Types F and K have extremely low fluctuations ( $5 \text{ MJ/m}^2$ ); types B, G and L have low fluctuations ( $10 \text{ MJ/m}^2$ ); types C, H and M have medium fluctuation ( $15 \text{ MJ/m}^2$ ); and type D has a high fluctuation ( $20 \text{ MJ/m}^2$ ).

These maps show that, with the exception of a few areas, such as southern China, the islands of Indonesia along the equator and the extreme south of Australia and New Zealand, the ESCAP region is a very favourable one for solar energy applications.

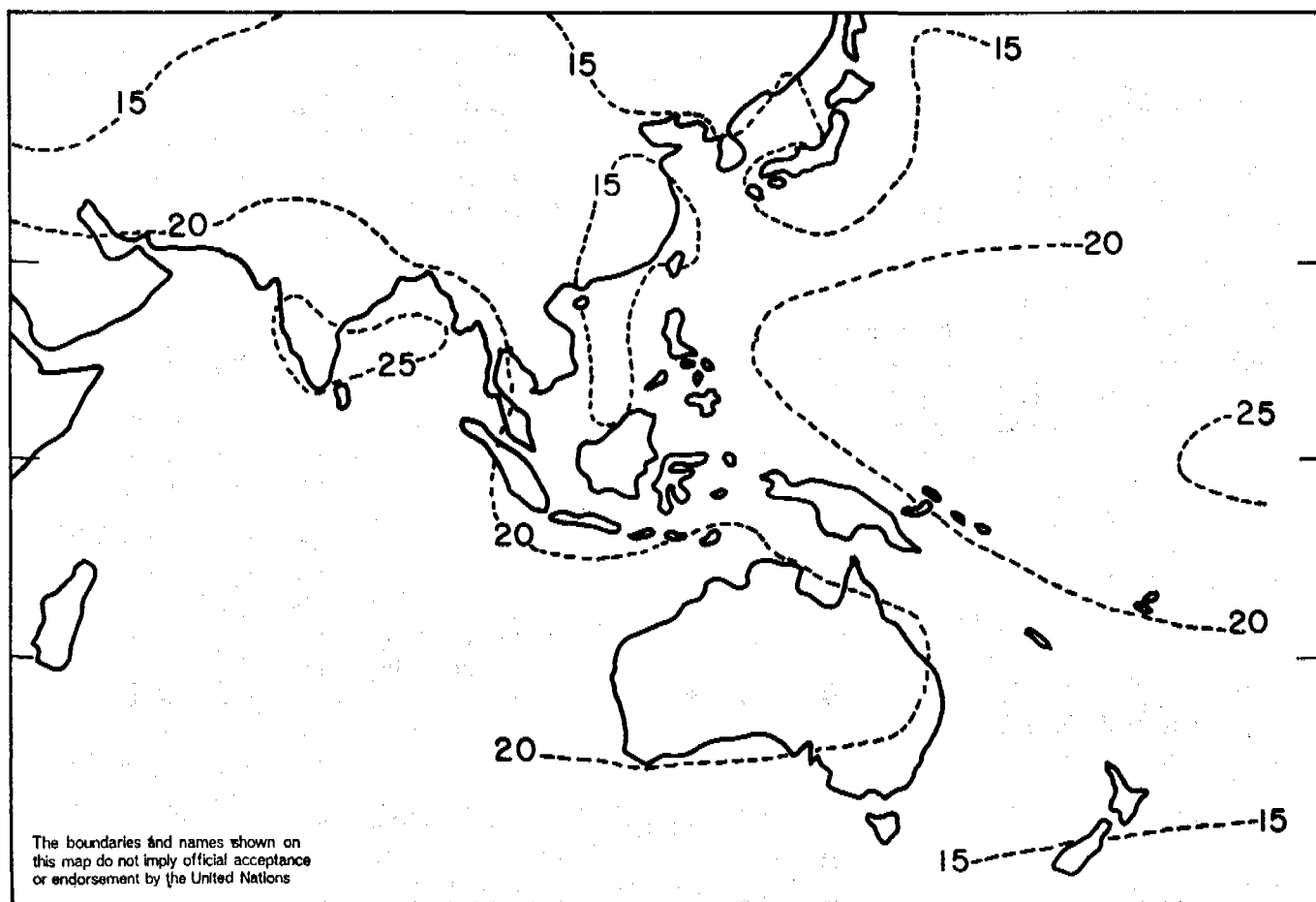

Map 1. Mean daily global solar irradiance in the ESCAP region in March ( $\text{MJ/m}^2$ )

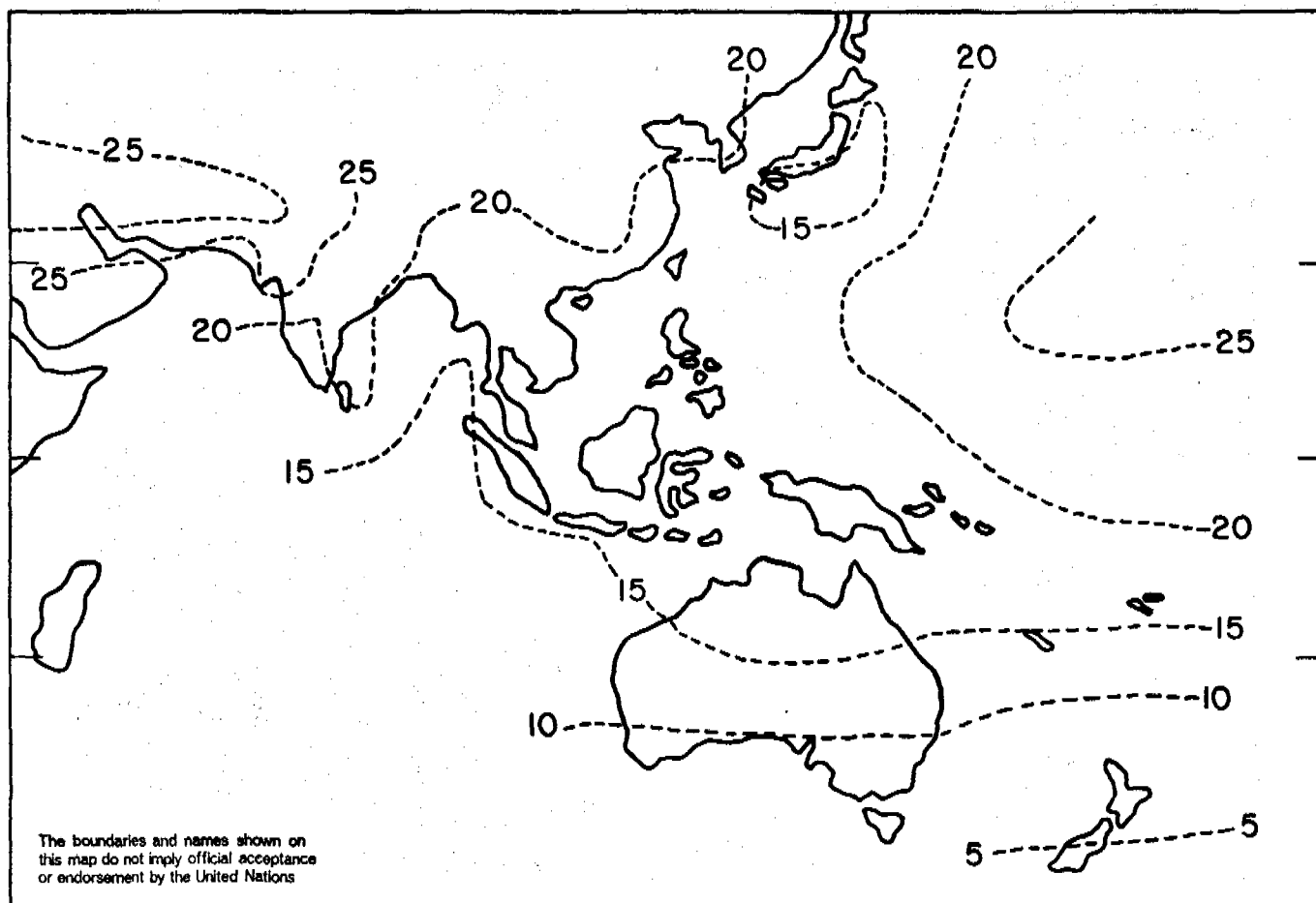

Map 2. Mean daily global solar irradiance in the ESCAP region in June (MJ/m<sup>2</sup>)



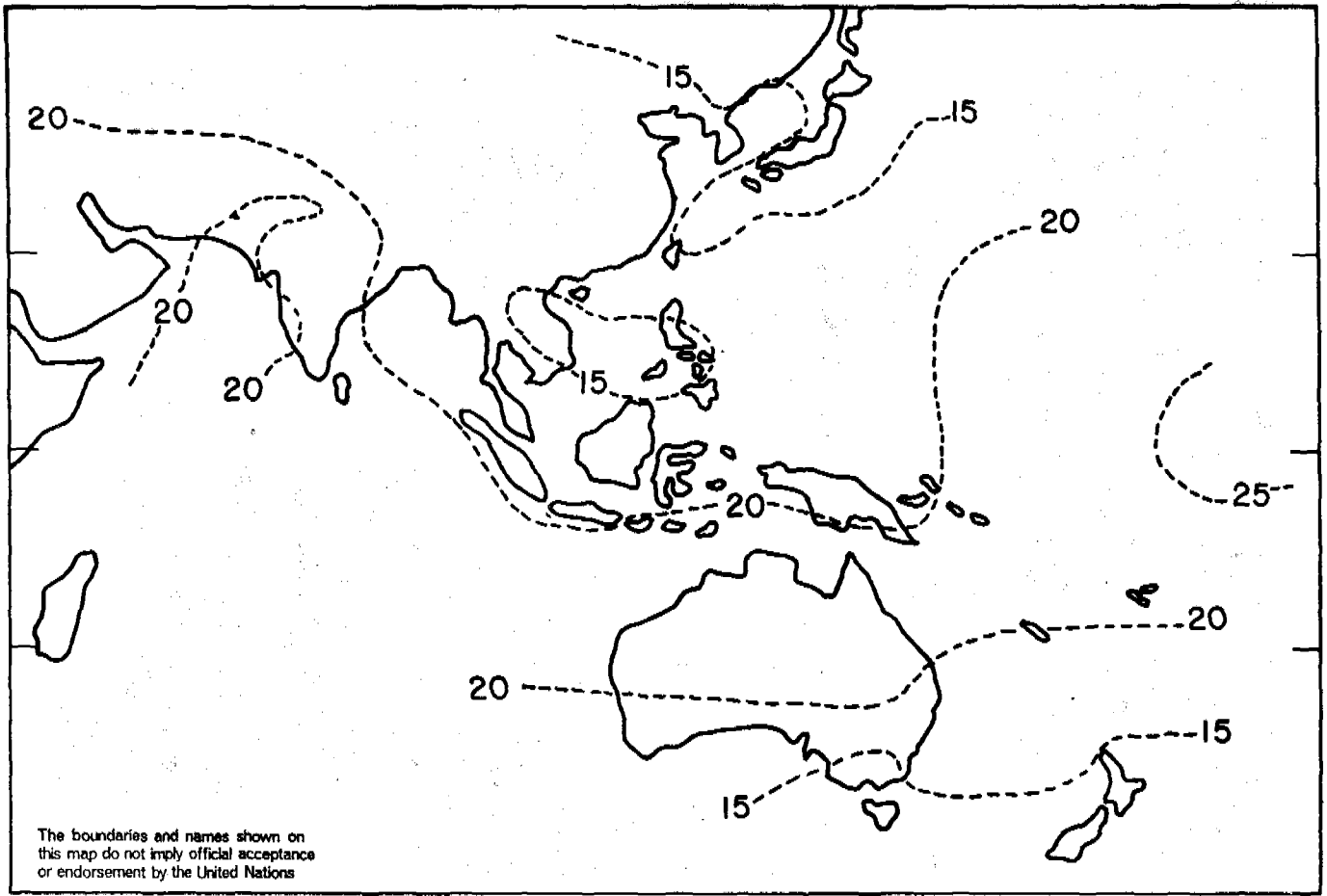

Map 3. Mean daily global solar irradiance in the ESCAP region in September (MJ/m<sup>2</sup>)

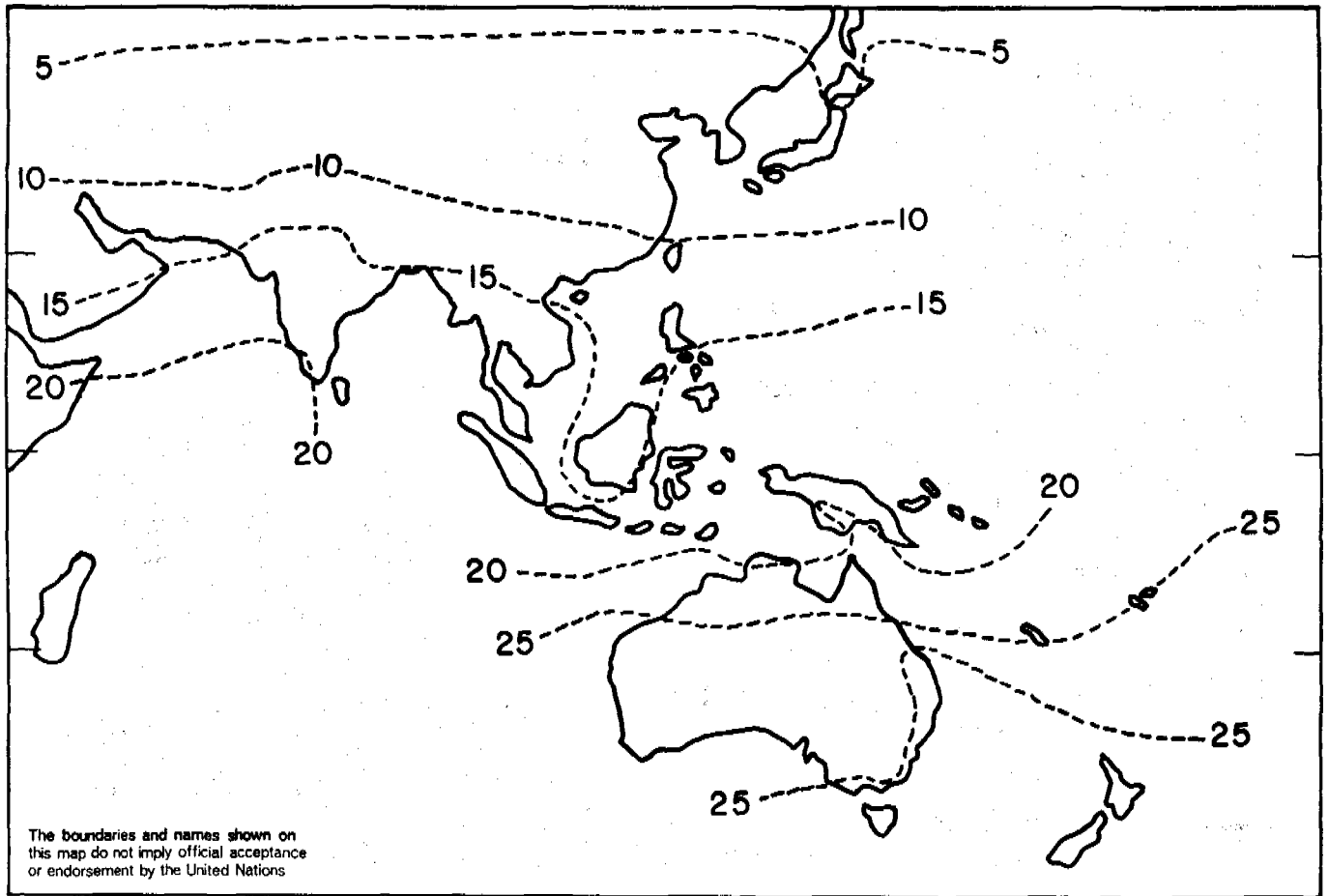

Map 4. Mean daily global solar irradiance in the ESCAP region in December ( $\text{MJ}/\text{m}^2$ )

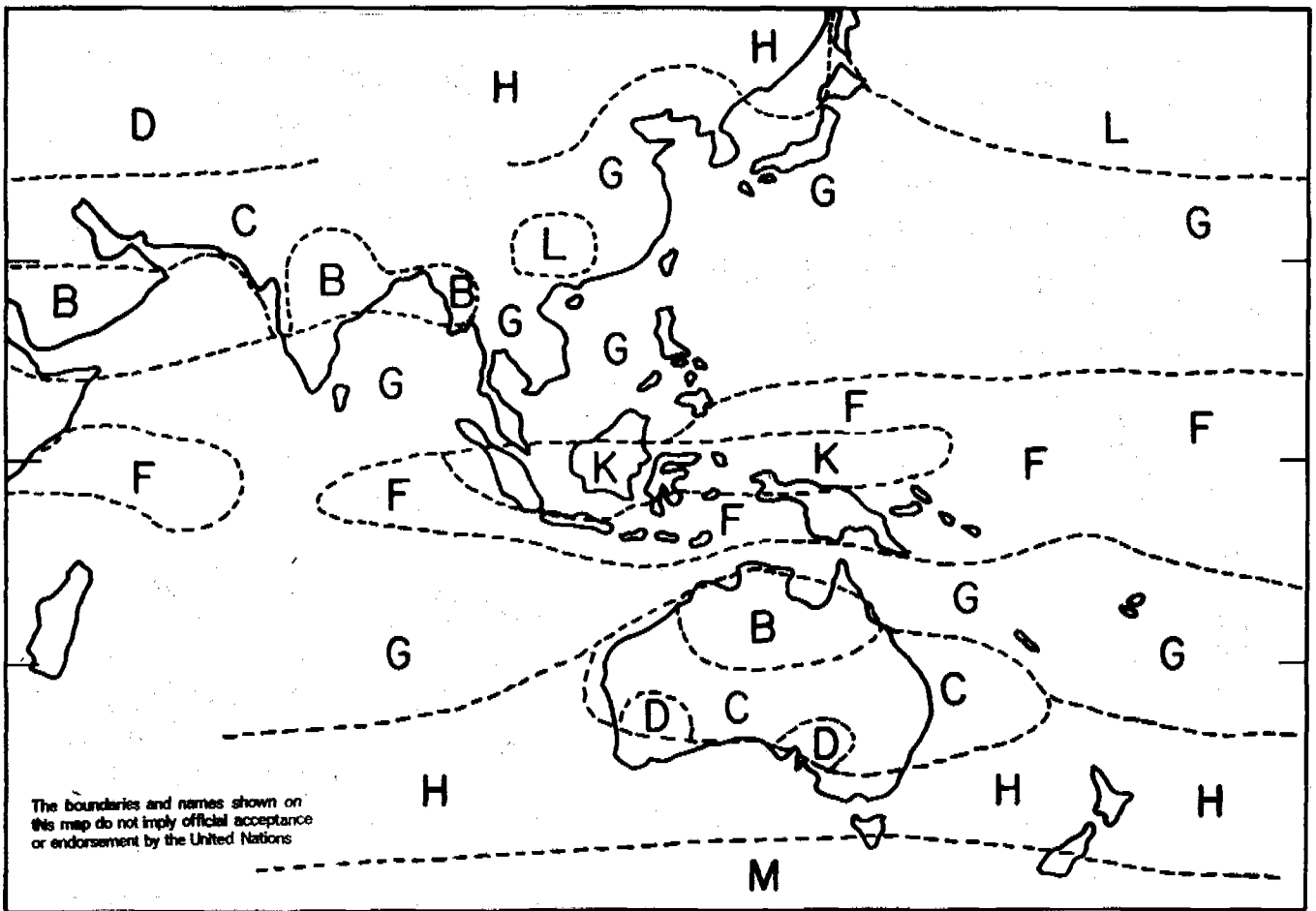

**Map 5. Principal solar radiation climates according to Terjung**

Source: Solar Energy, 1970

### C. Solar pumping technology

*Thermodynamic pumping systems*, although experimented on and off since the beginning of this century, have not been produced in large numbers or commercialized. The usual system consists of concentrators or flat-plate collectors delivering solar heat to a Rankine cycle heat engine that drives the pump (figure V). About sixty solar pumps of this type have been installed with non-commercial backing in developing countries, but because of their complexity few have operated for any length of time and the acquisition of spare parts has been a problem.

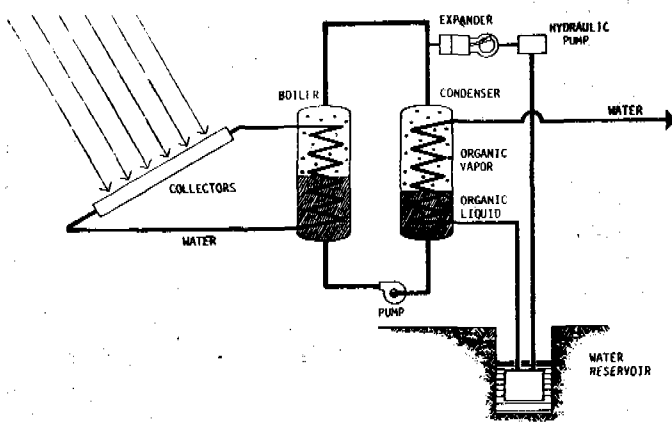

**Figure V. Solar-powered Rankine engine operated water pump**

Source: Georgia Institute of Technology, 1978.

The 1983 World bank study noted that, although they might in theory be competitive with PV systems, thermodynamic pumps were still unproven in the field, and the skills required to manufacture them were as high as for PV systems. A comprehensive review of small solar-powered heat engines has recently been published. Early work on solar thermal devices showed that the high efficiencies obtainable with concentrators are not sufficient to preclude serious consideration of flat-plate collectors where simple robust equipment is needed. Even so, solar thermal engines built in recent decades have been intended for communities without the means to buy them commercially, and outside assistance will remain necessary. Nevertheless, for political or economic reasons it is still possible that interest in solar thermal engines may be revived in the future. The potential for solar thermal pumps to compete with PV exists, as the following reports of recent developments show.

A few years ago in India a 100 W solar thermal reciprocating water pump prototype working on the low temperature organic Rankine cycle was designed, fabricated and tested in collaboration with Swiss engineers. The technical problems were solved but the system was found not to be economically viable at that time.

However, experiments with a 1 kW solar thermal pump in Indonesia, in collaboration with Germany, have demonstrated its promise for meeting the drinking water supply needs of the rural population there. Five units tested in the field were found to be reliable but interface problems between the system and the site conditions (well capacity, water quality, etc.) occurred. Further field tests are necessary. A joint Indo-German project has led to the successful demonstration of a solar thermal pump similar to the pump in Indonesia. This pump has worked well for six years and is reported to be significantly cheaper than a comparable PV system.

*Photovoltaic (PV) pumping systems* are relatively simple in concept and a reliable technology exists. For this reason, and because the economics of solar PV pumping systems is approaching viability, many thousands of these systems have been installed in various places. A PV system consists of:

- A photovoltaic array to convert solar radiation into electrical power
- A power conditioning system to convert the power output of the PV array into a suitable form
- An electric motor to convert the electrical power into mechanical power
- A water pump
- A water delivery system.

A *photovoltaic array* consists of a number of modules, or panels, mounted together on a supporting structure to receive solar radiation. Each module consists of individual solar cells connected in series and parallel to give suitable voltages and currents for various applications. A typical module may be of size 1 m by 0.3 m by 50 mm thick containing 36 cells, each of diameter 100 mm.

The conventional solar cell is made of a thin monocrystalline wafer doped first with boron, and then at the surface with phosphorus to create a second layer.

When sunlight is absorbed by the cell a potential difference occurs between the front and back of the cell that will cause a direct current to flow if the surfaces are connected to an electrical load.

Photovoltaic modules are rated in peak watts (Wp). This is the maximum power output from the module at a cell temperature of 25°C and solar irradiance 1 kW/m<sup>2</sup>. A typical module may have a rated output of 36 Wp at 12 V and 3 A. The actual power obtained from the module in the field is generally less than the rated power because: (a) the efficiency of a solar cell decreases as its temperature increases and cells in the field may be hotter than 25°C, (b) the solar irradiance is less than 1 kW/m<sup>2</sup>, and (c) imperfect matching of the load may cause the module to operate at a voltage and current that gives a power output less than the maximum. For these reasons the average output over the daylight hours may be less than half the rated output, even in a location with high average daily solar radiation.

The conventional monocrystalline silicon cell is very expensive to produce, mainly because of the cost of refining the raw silicon, and because a large quantity of the refined silicon is lost as waste when the block is cut into wafers. Alternative technologies have therefore been developed in an attempt to reduce the cost of solar cells, including the use of polycrystalline cells and amorphous silicon deposited on glass, both of which are on the market. It is likely that large-area thin-film solar cells made from deposits of cadmium sulphide and cadmium telluride on glass will be available soon.

The cost of PV cells still severely limits their widespread use. The current world price for high volume orders of conventional silicon solar panels is \$US 5 per Wp. Technological improvements will reduce the price to \$US 3 per Wp by the mid-1990s. The new large-area thin-film technology offers promise for lower prices in the future: perhaps \$US 1 per Wp by the year 2000. It should be understood that these figures are appropriate for large volume orders, and do not include the extra costs of distribution. The forecast of \$US 1/Wp is, of course, somewhat speculative at the present time for a technology still at the experimental stage.

*The power conditioning system may contain:*

- Impedance matching devices
- Direct current to alternating current inverters
- Batteries for electrical storage
- Switches and protective cutouts

The purpose of *impedance matching devices* is to produce high currents for starting pump motors, especially when reciprocating pumps are used, and to maximize the power available from the PV array while the system is running. Under steady conditions the maximum power output occurs at an optimum voltage slightly less than the open circuit voltage, but the optimum varies slightly as the solar radiation varies. A "maximum power point tracker" is an electronic device for optimizing the voltage as operating conditions vary. Its use adds cost to the system, so the simpler method of fixing the voltage at a value near the optimum for most working conditions may be preferable. Since a PV array produces a direct current, inverters are needed when AC motors are used to drive the pump. The use of an inverter may entail a significant loss of power unless it is designed specially for the pumping system.

*Batteries* also provide impedance matching by allowing the motor to start at low irradiance levels and by supplying power at a fixed voltage. However, most solar pumping systems do not include batteries because of problems such as the need for regular maintenance, short life, and power loss. Energy storage in water pumping systems is usually in the form of lifted water rather than electric batteries.

*The electric motors* used in solar water pumping systems are of three types:

- Brushed permanent magnet DC motors
- Brushless permanent magnet DC motors
- AC motors

The obvious advantage of DC motors is that no inverter is required. Brushed DC motors, in which the armature rotates in the field of a fixed permanent magnet, are traditional and reliable, but the brushes must be replaced after one or two years. The brushless DC motors have a rotating permanent magnet that generates a current in electronically commutated field windings. They are a new development but are on the market and are likely to become the preferred option in small PV pumping systems. For large systems AC motors may be used; they should be specially designed together with the inverter for maximum efficiency to offset the inherent power losses.

*The water pumps* used in PV pumping systems are of two principal kinds:

- Centrifugal pumps
- Positive displacement pumps

*Centrifugal pumps* have a rotating impeller that throws the water radially against a casing so shaped that the momentum of the water is converted into useful pressure for lifting. They are designed for optimal performance at a fixed head and rotation speed. Because they are not self-priming they are used as submersible pumps, or as suction pumps for lifts less than 5 m. For deep well operation several centrifugal impellers may be used in series to form a multi-stage pump.

*Positive displacement pumps* of two types are used in solar pumping systems: reciprocating pumps and helical rotary pumps. The water output of these pumps depends on their speed of operation, and is almost independent of the head. Reciprocating pumps may be used as low lift suction pumps. For medium to high heads they may be submersible. They are better for high heads than for low heads because the frictional forces are smaller relative to the hydrostatic forces at high heads than at low heads.

*Five system configurations* found in solar pumping are illustrated in figure VI. Their characteristics are summarized below.

*Type (a): submerged motor and multistage centrifugal pump.* The number of stages in the centrifugal pump depends on the lift required. This system is suitable for large heads (10-100 m) and for high flow rates (over 5 m<sup>3</sup>/h, depending on the pumping head). An advantage of this system is that the straightness of the well is not critical for the proper operation of the pump. A disadvantage is that the motor-and-pump unit must be removed from the well for maintenance and repair.

*Type (b): submerged centrifugal or helical rotary pump driven by a shaft from a motor at ground level.* This type of system is suitable for medium heads (10-50 m). It has the advantage that the motor is accessible for maintenance and repair above the ground. A disadvantage is that the straightness of the well and the alignment of the shaft are critical for proper operation.

*Type (c): submerged reciprocating positive displacement pump driven by a rod from a "nodding donkey" at ground level.* This type of pump is suitable for medium depths (10-50 m), which are limited by the mechanical strength of the rod. Flow rates, which are governed by the running speed of the motor and are not much influenced by the pumping head, are generally low (2 m<sup>3</sup>/h). The system has the advantage that the motor is above the ground. Disadvantages are that the straightness

of the well and the alignment of the rod are critical for proper operation, and the system needs a high force to start.

*Type (d): floating unit with motor and submerged centrifugal pump.* This type of pump is used in lakes, rivers and shallow wells for low lift (up to 5 m).

*Type (e): surface-mounted motor and suction pump with self-priming tank.* The pump may be a centrifugal pump or a positive displacement pump. Centrifugal pumps are more efficient, but positive displacement pumps have better self-priming. The system is suitable for low heads (up to 5 m).

A list of *commercially available PV pumping systems* was published by IT Power in 1986. The present section gives information about some of the systems currently being advertised in company brochures (1990). These systems are mentioned here only as examples of what is available; no attempt has been made to survey the market comprehensively.

(1) A brochure from France shows a PV generator of 48 modules (2 kWp) providing electricity to floating motor-and-pump units (type (d) above) suitable for irrigation in market gardens and agricultural fields of 3-5 ha. The total cost, including installation and maintenance, was 250,000 francs, i.e. \$US 50,000, which would be high compared with 1991 prices.

(2) A brochure from the United Kingdom shows sketches of solar-powered floating pumps for irrigation, water supply or water circulation from rivers, lakes, canals or shallow wells of type (d) above. Also solar-powered borehole pumps that supply water for drinking and irrigation of type (a) above are shown. The water is extracted from wells ranging in depth from 5 m to more than 100 m. No prices are given, but it is said that the low running costs mean that the initial investment can soon be recovered.

(3) A brochure from the Netherlands offers a wide range of systems, each using the most suitable pump for each application in two basic versions:

(a) Drinking water systems, which show a great variety in head and discharge, utilize a long-life single or multi-stage centrifugal submersible pump. The head is 10-100 m, the discharge is 5-100 m<sup>3</sup>/d, and the application is for a 6-inch tube well up to 15 m or a 4-inch tube well up to 100 m.

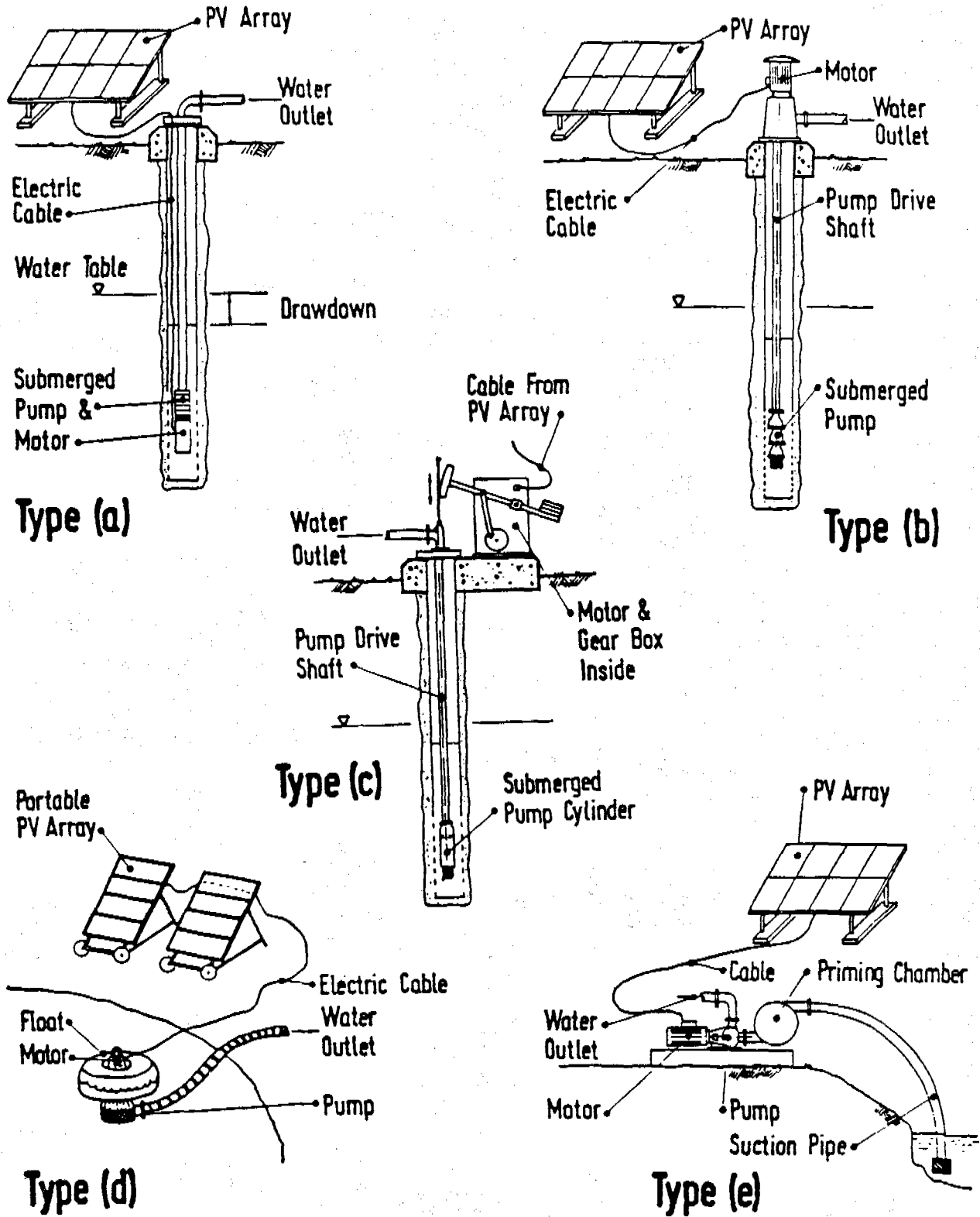

Figure VI. Principal configurations of solar pumps

Source: McNelis, B. and others, 1988.

- (b) Small-scale irrigation systems usually utilize low-lift, large discharge pumps with head 1-10 m, discharge 100 m<sup>3</sup>/d and application for open wells or surface water.
- (4) A brochure from the United Kingdom describes several different ranges:
- (a) A DC submersible pump that will raise water from depths of 5-65 m and deliver up to 2.8 m<sup>3</sup>/d at average insolation levels of 6 kWh/m<sup>2</sup> per day using one or two solar PV modules.
- (b) Easily portable ground-mounted packages that can pump up to 6 m<sup>3</sup>/d at a head of 20 m with three solar PV modules at insolation level of 6 kWh/m<sup>2</sup> per day.
- (c) Larger systems with a floating pump for low heads (up to 10 m) and a submersible pump for bore-hole use to a depth of 120 m. They can pump up to 270 m<sup>3</sup>/d at insolation level of 6 kWh/m<sup>2</sup> per day. Because of the large number of variables involved (head, volume, location, application, etc.) these larger systems are always sized individually by the manufacturer to ensure that the system selected provides the most efficient and cost effective solution.

The solar modules are guaranteed for 10 years. The pumps are withdrawn from the boreholes for checking every six months.

(5) A brochure from Denmark describes in detail a wide range of pumping systems with submersible AC motor-pump units made entirely of stainless steel. The solar array feeds DC power into a DC-AC inverter to drive the motor-pump unit (figure VII). A typical array is 1.5 kWp with nominal output voltage 105 V and variable current depending on the irradiation on the array. The inverter produces a three-phase AC output current of 14 A whose voltage and frequency vary (7-63 Hz). The conversion efficiency of the inverter is 96 per cent. The performances of the systems in the range with irradiation on the array 6 kWh/m<sup>2</sup> per day are shown in figure VIII.

(6) A brochure from Italy offers a simple oscillation hand pump that can also be operated by a 320 Wp solar module at pumping depths up to 50 m with capacity up to 8 m<sup>3</sup> per day (figure IX). There is a simple system for manual tracking of the panel with seasonal adjustment or three settings daily, and the pump can still be operated manually in the absence of sufficient solar radiation (eg. at night). The additional cost for the PV attachment is reported to be \$US 5,000, or \$US 1.25 per annum per person assuming it lasts 20 years and the pump serves 200 people.

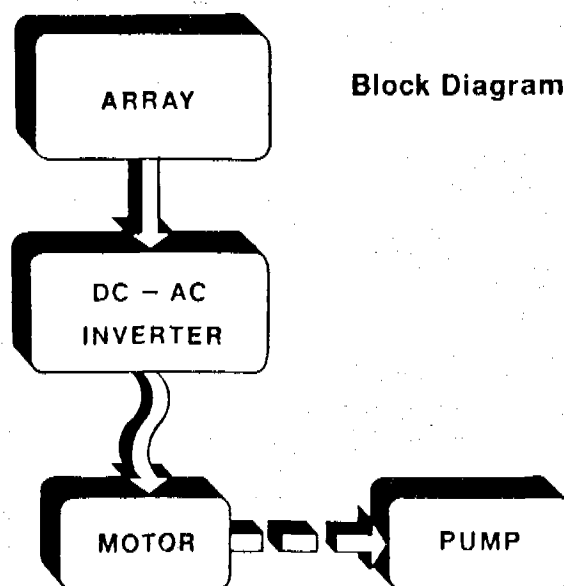

**Figure VII. PV system with DC-AC inverter**

(7) A brochure from Japan describes a wide range of motor-pump systems for different heads and water volumes. There are two basic types: simple DC units suitable for small-scale irrigation systems in developing countries, and more elaborate AC systems employed where larger amounts of water are required. The DC systems operate with solar arrays of 240-600 Wp pumping 15-130 m<sup>3</sup>/d of water at heads of 2-6 m. The AC systems have solar arrays of 0.6-4.8 kWp, whose DC output is converted to 50 Hz three-phase AC. These AC systems have outputs of 10-100 m<sup>3</sup>/d at heads of 10-90 m.

(8) A brochure from a firm in France that has installed many PV pumping systems in Africa mentions submersible pumps from 640 Wp to 3.84 kWp and floating pumps from 240 Wp to 5 kWp.



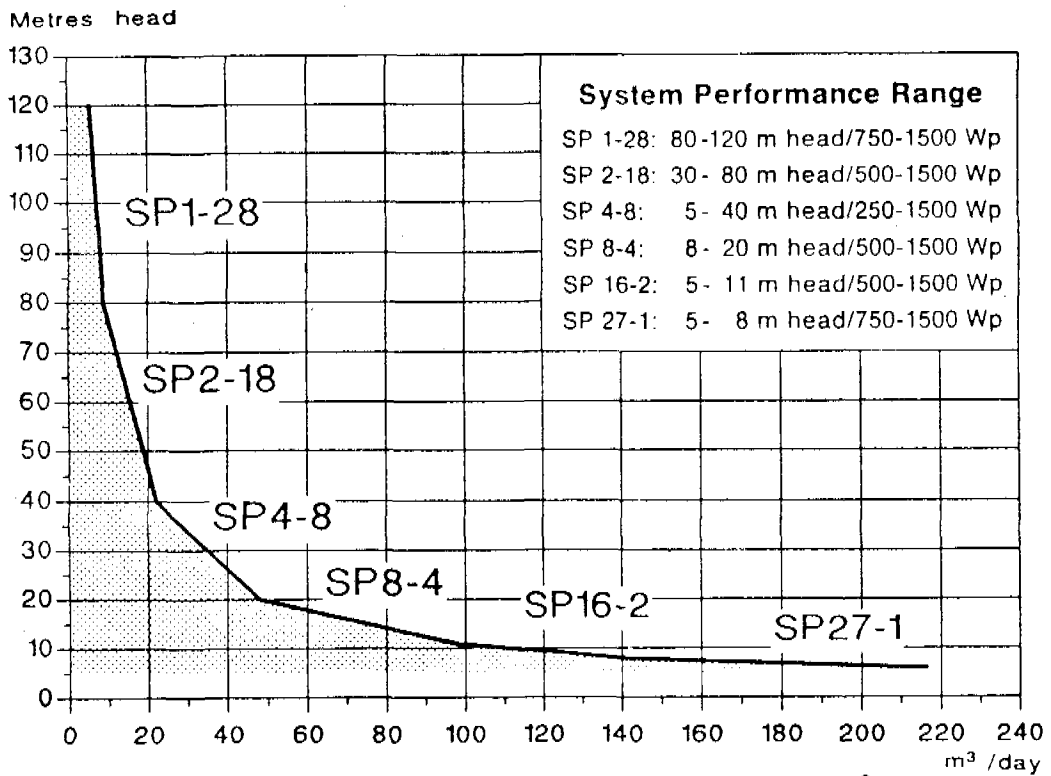

Figure VIII. PV pump performances with irradiation 6 kWh/m<sup>2</sup> per day

Source: GRUNDFOS brochure

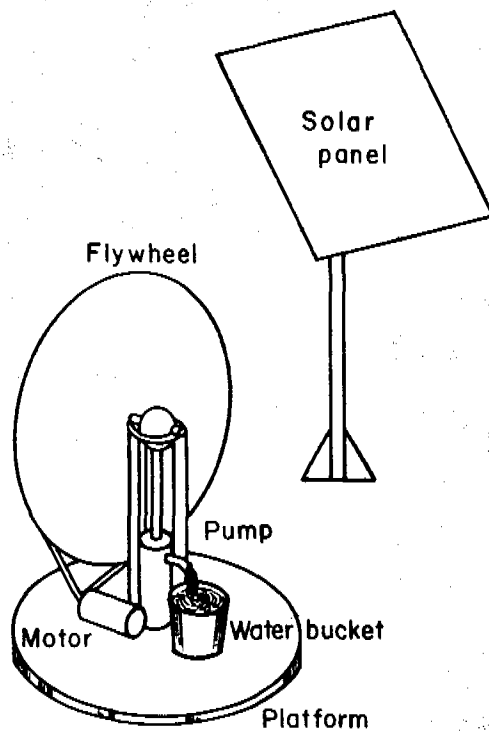

Figure IX. Simple oscillation pump operated by hand or by PV array

### D. Design of a PV solar pumping system

Because the cost of a PV solar pumping system is roughly proportional to the size of the system, especially the size of the PV array, the system chosen for a particular application should be the smallest that provides the amount of pumped water needed. The average daily solar irradiation at the site in the least sunny month of the year may be taken together with the maximum daily water requirement to determine the array size. The whole process of designing a system may be divided into stages as follows:

(a) *Assessing water requirements:* pumped water requirements depend on local factors. Rough estimates for irrigation, domestic use and livestock in tropical areas are typically as follows:

- domestic use in villages 30 l/d per person
- livestock 40 l/d per animal (cattle, horses)
- village farming 60 l/d per hectare, rice 100 l/d per hectare

The daily requirements for people and animals are normally constant, but irrigation requirements usually vary with the seasons of the year. The demand for domestic use varies markedly in response to the supply available. For example, a village of 250 people using 30 l/d per person would require a total domestic water supply of 7.5 m<sup>3</sup>/d.

(b) *Calculating the hydraulic energy required:* the daily hydraulic energy requirement (J/d) is the product of the volume of water to be pumped per day (m<sup>3</sup>/d), the density of water (1000 kg/m<sup>3</sup>), the acceleration of gravity (9.8 m/s<sup>2</sup>), and the head (m). Divided by 10<sup>6</sup> one obtains the daily energy requirement in units of MJ/d. In addition to the energy required for lifting the water, allowance has to be made for frictional losses in the pipework. In the absence of detailed calculations an extra 10 per cent may be added to the energy for lifting to obtain a first estimate of the total hydraulic energy requirement. For instance, suppose the pumping head in the previous example is 25 m. Then the lifting energy requirement is 1.84 MJ/d. Adding 10 per cent to allow for friction losses we obtain a hydraulic energy requirement of 2.02 MJ/d.

(c) *Determining the available solar energy* has already been discussed in detail in section B. The average daily solar irradiation each month on an optimally tilted array should be estimated for the site, using if necessary

data for irradiation on a horizontal surface with the appropriate corrections. It is not sufficient to use the annual average daily solar irradiation because the performance of the system designed on this basis may fail to meet requirements in months with low solar radiation. It is convenient to convert the daily solar radiation in MJ/m<sup>2</sup> to kWh/m<sup>2</sup> and divide it by 3.6 MJ/kWh.

Continuing our example, we shall suppose that the average daily solar irradiation available in the worst month is 16 MJ/m<sup>2</sup>d. This is equal to 4.44 kWh/m<sup>2</sup>.

(d) *Sizing the components of the system:* it is usually done by the suppliers. The components that have to be selected are: the PV array, the motor, the pump, and the pipe diameter. It is beyond the scope of this report to discuss the selection procedure in detail. However, the main principles may be outlined as follows:

(i) First, one estimates the electrical energy required by dividing the hydraulic energy requirement by the efficiency of the motor-pump subsystem. For pumping systems operating at low heads (2-5 m) the efficiency may be 0.3, while for systems operating against higher pumping heads (10-30 m) an efficiency of 0.4 may be assumed. The units of the electrical energy requirement can be converted from MJ/d to kWh/d by dividing by 3.6 MJ/kWh. For example, taking the hydraulic energy requirement of 2.02 MJ/d, and assuming a motor-pump efficiency of 0.4 (for the total pumping head 27.5 m, which is in the range 10-30 m), we obtain the electrical energy requirement of 5.05 MJ/d, or 1.40 kWh/d.

(ii) To size the PV array, one compares the electrical energy requirement per day with the available solar irradiation per day. The numerical value of the total daily solar irradiation in units of kWh/m<sup>2</sup> is the number of hours at the peak irradiation of 1.0 kW/m<sup>2</sup> that would give the same total energy as the daily solar irradiation. Dividing the electrical energy requirement per day by this number of hours gives the required output from the solar PV array in kWp. However, to allow for temperature effects and impedance mismatching losses, 20 per cent

may be added to the required output in order to estimate the peak rating of the array needed to operate the pumping system. A diagram for approximate sizing of the PV array graphically is shown in figure X.

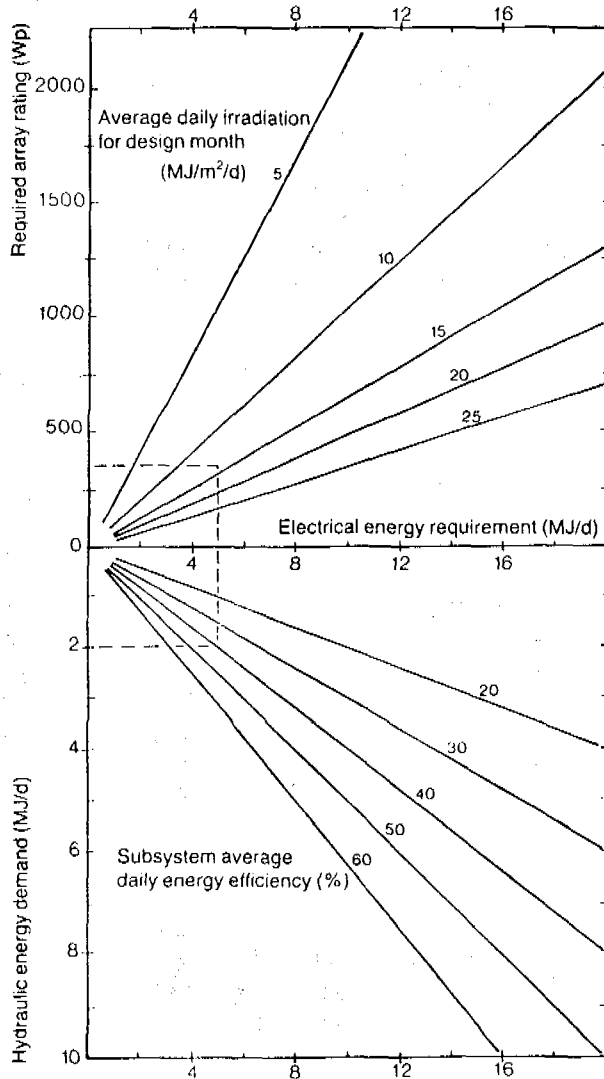

**Figure X. Approximate sizing of PV pumping system**

Source: IT Power, 1983.

For example, the available solar irradiation of 4.44 kWh/m<sup>2</sup>d gives the same total energy as 4.44 h of peak irradiation. To obtain the required daily electrical energy of 1.40 kWh in this time the output of the PV array must be 0.315 kW. Adding 20 per cent to allow for temperature effects and mismatching losses we estimate the required peak rating of the array to be 378 Wp. If the array consists of 36 Wp modules, then eleven modules are needed

and the total rating of the array will be 396 Wp.

(iii) The remaining system components to be selected are the motor, the pump and the diameter of the pipes. The electric motor must be able to withstand the maximum output of the PV array, so the rating of the motor must be at least as great as the PV array rating. Furthermore, the configuration of the PV array and the current and voltage limitations of the motor must be properly matched. The pump chosen must be capable of delivering the water flow rate that occurs against the total head (lift head plus friction head) at the peak hydraulic power (the peak PV array rating multiplied by the efficiency of the motor-pump subsystem). Finally, the diameter of the pipes should be such that if possible the friction head loss does not exceed 10 per cent of the total head. Figure XI shows the friction head in smooth pipes for different internal diameters.

In the continuing example since the rating of the PV array is 396 Wp and the rating of the motor must not be less than this, a 400 W motor should be selected. Again, since the rating of the PV array is 396 Wp and the assumed efficiency of the motor-pump system is 0.4, the peak

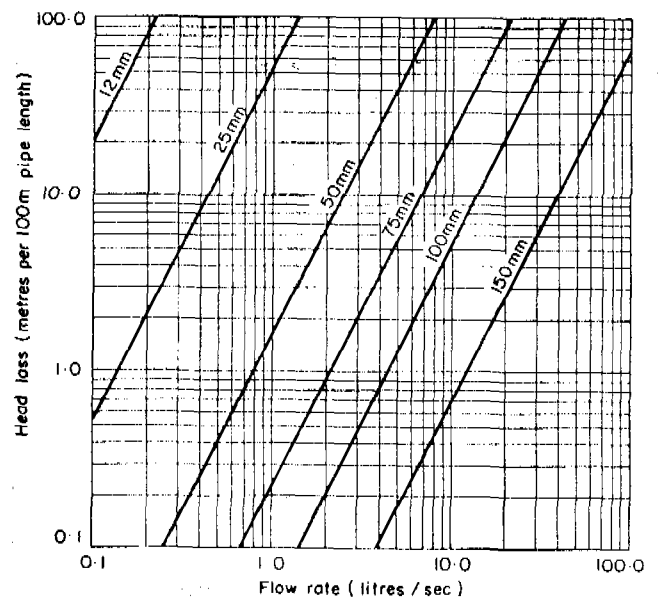

**Figure XI. Friction head in smooth pipes of different internal diameter**

Source: IT Publications, 1985.

hydraulic power is 158.4 W. Then, for a lift head plus friction head of 27.5 m, the peak water flow rate is 0.6 l/s. If the total length of pipe (for lifting and delivering the water) is 100 m, then, for a friction head loss of 2.5 m at a flow rate of 0.6 l/s, one needs a pipe of 35 mm internal diameter.

(e) *Specifying the system configuration:* a performance prediction for the system can be made after a configuration has been specified. The technical data required for this assessment include: the static lift head, the length and internal diameter of the delivery pipes, the rating and tilt of the PV array and the motor-pump subsystem efficiency. One can then take the average daily solar irradiation on the PV array each month to predict the average amount of water pumped per day each month by means of a calculation that is essentially the reverse of the method described above for designing the system. If the system is sized so as to provide the required amount of water in the worst month, there will be surplus energy in the other months which could be used to drive other loads.

(f) *A performance evaluation* can be made for a system that has already been installed by observing the actual output. Such evaluations are important to verify

the appropriateness of the design and to improve knowledge of the behaviour of solar pumping systems in the field. The following data and instrumentation are needed:

- daily total solar irradiation on the plane of the PV array, measured by means of a solarimeter and integrator,
- daily electrical output of the PV array, measured by means of an energy meter,
- daily volume of water pumped, measured by means of a flow meter and integrator,
- static head, measured manually once a day with a well dipper bearing a water-sensitive transducer.

A comparison between the daily total solar irradiation on the plane of the PV array with the daily electrical energy output enables one to determine the efficiency of the PV array subsystem. A comparison between the electrical output and the daily hydraulic energy (from the daily volume of water pumped multiplied by total head) enables one to determine the efficiency of the motor-pump subsystem. The efficiency of the whole system is the product of these two subsystem efficiencies.

## E. Economics of solar pumping

The economic evaluation of solar pumping seeks to determine the value of solar pumping to a community in comparison with alternatives. Alternative ways of obtaining water without pumping may include collecting rainwater, diverting water from mountain streams, or bringing in water with motor vehicles. Alternative sources of energy for pumping may include grid electricity, diesel engines, solar energy, wind power or hand pumping. If the benefits obtained by installing a solar pumping system exceed the cost of installing and operating the system, and if the cost of a solar pumping system is less than the costs of other pumping systems, then the solar system will be judged economically feasible, and it will be advantageous for the community to have the solar pumping system installed.

*Pure economic evaluation* seeks to assess the true value of solar pumping independent of the distorting effects of taxes and subsidies. This should be distinguished from *financial evaluation*, which seeks to determine the actual outlay that must be paid by the community in order to obtain and use the system. Thus, if taxes are light on diesel fuel (to help large numbers of existing small-scale users) but are heavy on PV modules (because they are regarded as luxury electronic items), then PV solar pumping will suffer an artificial disadvantage versus diesel pumping. On the other hand, donations or the subsidized installation of solar pumps in a community may give the false impression that the pumps are economically feasible in conditions where in fact they are not. The methods of economic evaluation discussed in this report do not include the consideration of taxes and subsidies.

Field experience has shown that the feasibility of a water pumping system depends, in general, on the daily hydraulic energy requirement. Hand pumping may be used for small daily hydraulic energy requirements, solar and wind are suitable for intermediate energy requirements, and diesel energy is likely to be the choice for large daily requirements. Table 2 indicates rough assessments of these economic feasibility ranges. It must be emphasized, however, that the figures given in the table are very approximate and conditions may vary greatly from one locality to another.

**Table 2. Approximate economic feasibility ranges for water pumping technologies**

Hand pumping:	Less than 0.5 MJ/d
Solar, Wind:	0.5 - 50 MJ/d
Diesel:	More than 50 MJ/d

The costs of a water pumping system may be divided into two kinds: capital costs and recurrent costs. The *capital costs* of the whole water supply system may include: the costs of constructing a well, a storage tank, and a distribution system in addition to the provision of the pump. Transportation and installation of the pumping system must also be included in the capital costs.

The *recurrent costs* include: operating costs, for fuel (if applicable) and labour, the costs of maintenance and repair, and the cost of replacing worn out equipment. Solar pumps and wind pumps have high capital costs and low recurrent costs; diesel pumps have lower capital costs, but their recurrent costs are high.

A complete economic evaluation of a pumping system must include both capital costs and recurrent costs combined into a single quantity. In order to do this the annual recurrent costs over the whole lifetime of the system are discounted at the prevailing interest rate to *present worth* values in the year when the pump was installed. The present worth PW of a cost  $c$  incurred  $n$  years after installation is given by

$$PW = c/(1 + r)^n,$$

where  $r$  is the fractional discount rate. The present worth of the pumping system is the sum of the capital cost and the present worth of all the recurrent costs. For example: if the discount rate is 10 per cent, then  $r = 0.1$ , and an expenditure of \$US 100 three years after installation has a present worth of \$US 75.

The occurrence of inflation will complicate the calculations, and it may be desirable to adjust the interest rate used in order to arrive at realistic values of present worth. If, however, all prices are inflating at the same rate as the general inflation, the adjustments for inflation may be excluded when economic comparisons between different systems are being made. In the case of solar PV systems the price of PV arrays is expected to fall (i.e. to be deflated) in the future relative to the general inflation. However, this cost is a capital cost, and recurrent costs are small, so the calculation of the present worth of a particular system over its whole lifetime will not be affected by the expected relative deflation of the cost of PV arrays.

An alternative method of making the economic evaluation is to calculate the total *equivalent annual cost* over the lifetime of the system. Here the capital cost is converted into an equivalent annual cost that represents, in effect, the constant amount that would have to be paid annually over the lifetime of the system to repay a loan at the prevailing interest rate equal to the capital cost at the start. The equivalent annual cost EAC of an initial capital cost  $C$  for a system with expected lifetime  $n$  years is given by

$$EAC = Cr(1+r)^n / ((1+r)^n - 1),$$

where  $r$  is the fractional discount rate. The total equivalent annual cost is the sum of the equivalent annual cost of the capital cost plus the annual recurrent cost. A knowledge of the total equivalent annual cost enables one to calculate the equivalent cost of the system per day, and hence the cost of the daily water output.

*Example:* the equivalent annual cost of a system with initial capital cost \$US 10,000 and expected lifetime 20 years with discount rate 10 per cent is \$US 1,175.

Table 3 shows, as an example, a cost comparison for a diesel pump, a wind pump, and a solar PV pump for pumping 27 m<sup>3</sup>/d at a head of 30 m under a particular set of assumptions. Under these assumptions the wind pump provides the least cost of water pumped (\$US 0.16/m<sup>3</sup>), the diesel pump is intermediate (\$US 0.23/m<sup>3</sup>) and the solar pump provides the water at the highest cost (\$US 0.28/m<sup>3</sup>). The main obstacles to the feasibility of solar pumping in this example are: first, the high capital cost (\$US 22/Wp), second, the low solar radiation in the critical month (14 MJ/m<sup>2</sup>d), and third, the favourable annual average wind speed (4 m/s). If the capital cost of the solar pump could be halved (\$US 11/Wp), then the solar pump would provide water at the same cost as the

wind pump, and would be the preferred choice in an environment more favorable for solar energy and less favourable for wind energy.

A recent study for Mali has indicated that PV pumping systems at capital cost \$US 12/Wp are typically competitive with diesel pumps up to daily volume-head products of 1000 m<sup>4</sup>/d (e.g. 40 m<sup>3</sup>/d at a head of 25 m) (figure XII). Since the prices of PV systems are still being reduced by improvements in manufacture and increasing sales, the economic future for PV pumping systems is promising. Today (1991) the world price for PV modules in high volume sales is about \$US 5/Wp. The prices of whole pumping systems, including the motor-pump unit, storage tank and distribution pipes, are in the range \$US 15-20/Wp, depending on the size.

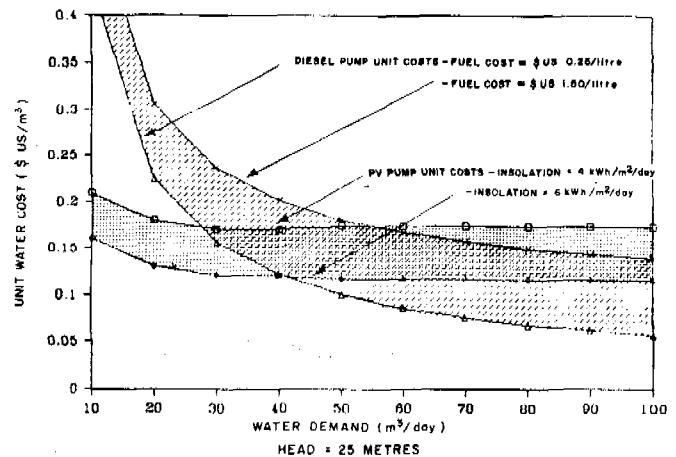

Figure XII. Solar pump and diesel pump cost comparison

Source: McNelis, B. and others, 1988.

Table 4 shows in more detail present and projected size specific costs of solar pumping systems. The costs shown are F.O.B. for the motor/pump subsystem. There is considerable variation of price between different systems having the same Wp rating especially for the small capacity systems where prices vary in the range \$US 8-20/Wp. The total system costs shown in the table include pipework, foundations, shipping, transport and labour for installation. The reduction in costs expected in the future will come from increased volume of sales, and the development of new solar cell manufacturing techniques. In the long run it appears that the cost of the PV array will become less significant than the cost of the rest of the system; even today the cost of the array is less than half of the total cost.

**Table 3. Cost comparison of a diesel pump, wind pump and solar pump for a particular location**

Location data:

Water requirement	27 m <sup>3</sup> /d
Pumping head	30 m
Annual average wind speed	4 m/s
Critical length of calm periods	5 days
Monthly average irradiation (in critical month)	14 MJ/m <sup>2</sup> /d (4 kWh/m <sup>2</sup> /d)
Critical length of cloudy periods	3 days
Smallest size of diesel engine available	3 kW rated power
Cost of 3 kW rated diesel pump	\$US 4500
Price of diesel fuel	\$US 0.50 /litre
Cost of wind pump	\$US 350/m <sup>2</sup> of swept rotor area
Cost of solar photovoltaic pumping system	\$US 22/Wp installed
Unit cost of water storage tank	\$US 30/m <sup>3</sup>
Discount rate	8%

Cost calculation: *diesel pump*

Hydraulic energy output requirement	2.25 kWh/d
Size of diesel engine	(smallest available engine) 3 kW rated power
Capital cost of diesel pump (3 kW rated power)	\$US 4500
Nominal power output	2 kW
Efficiency of pump	40%
Hydraulic power output of engine	0.8 kW
Water output	4.1 l/s
Hours of operation required per day	1.83 hours
Efficiency of engine	15%
Fuel consumption per hour operation	1.34 litres of diesel/hour
Fuel consumption per year	895 litres of diesel/year
Capacity of storage tank	1 day's supply = 27 m <sup>3</sup>
Capital cost of tank	\$US 810
Lifetime of tank	20 years
Lifetime of engine	5 years
Lifetime of pump	10 years
Capital cost on annual basis:	
engine and pump	\$US 960
tank	\$US 95
Annual fuel costs 895 litres at \$US 0.50/litre	\$US 450
Annual costs of operation and maintenance:	
engine and pump (5% of capital cost)	\$US 225
tank (2% of capital cost)	\$US 15
Annual cost of operator	\$US 500
Total annual costs	\$US 2240
Water output per year	9850 m <sup>3</sup>
Unit cost per m <sup>3</sup>	\$US 0.23/m <sup>3</sup>

Table 3. (continued)

Cost calculation: *wind pump*

Hydraulic energy output requirement	2.25 kWh/d = 821 kWh/year
Swept rotor area	$821:0.9 V^3$
E hydr : $0.9 V^3$	= 14.25 m <sup>2</sup>
Capital cost of wind pump	14.25 x 350 = \$US 5,000
Lifetime of wind pump	15 years
Capacity of tank required	5 + 1 = 6 days supply = 160 m <sup>3</sup>
Capital cost of tank	\$US 4800
Lifetime of tank	20 years
Capital cost on an annual basis:	
wind pump	\$US 650
tank	\$US 560
Annual costs of operation and maintenance:	
wind pump (5% of capital cost)	\$US 250
tank and piping (2% of capital cost)	\$US 100
Total annual cost	\$US 1560
Useful water output per year	9850 m <sup>3</sup>
Unit cost per m <sup>3</sup> pumped	\$US 0.16/m <sup>3</sup>

Cost calculation: *photovoltaic pump*

Hydraulic energy output requirement	2.25 kWh/d
Efficiency of motor and pump	40 %
Electrical energy output requirement	5.63 kWh/d
Peak watt rating of system	1700 Wp
Installed cost of solar pumping system	1700 x \$US 22/Wp = \$US 15,400
Lifetime of solar pump	15 years
Capacity of storage tank required	3 + 1 = 4 days supply = 110 m <sup>3</sup>
Capital cost of tank	\$US 3300
Lifetime of tank	20 years
Capital cost on annual basis:	
solar pump	\$US 2010
tank	\$US 390
Annual costs of operation and maintenance:	
solar pump (2% of capital cost)	\$US 310
tank and piping (2% of capital cost)	\$US 65
Total annual costs	\$US 2775
Water output per year	9850 m <sup>3</sup>
Unit cost per m <sup>3</sup> pumped	\$US 0.28 m <sup>3</sup>

Source: Hofkes E.H. and J.T. Visscher, 1986



**Table 4. Projected costs of solar pumps**

	Peak PV array power (watts)	In 1986	Potential 1993-1996
Module cost (\$US/Wp)	All	6	2
Motor pump subsystem (\$US/Wp)	200	6	4
	500	3.5	2.5
	1000	2.0	1.5
	2000	1.5	1.0
Installation costs (\$US/Wp)	200	3	3
	500	2.5	2.5
	1000	2	2
	2000	1.5	1.5
Total installed cost (\$US/Wp)	200	15	9
	500	12	7
	1000	10	6
	2000	9	5

Source: IT Power, 1986.

The actual prices of motor pump sets typically vary in the range \$US 700-1,200 for low lift floating or suction pumps, and \$US 1,500-3,000 for borehole pumps (up to heads of 50 m). So far as the individual buyer is concerned it is the actual total capital cost that is important. It has been reported that small PV pumps are available costing under \$US 1,000. Pumping at low volumes, they can lift a few cubic metres of water per day, depending on isolation and head. In Australia one firm advertises a 150 Wp system costing \$US 3,000 that should lift 12 m<sup>3</sup> of water through a head of 10 m on a sunny day (7 kWh/m<sup>2</sup>), and correspondingly more or less water under other conditions.

Looking into the future, with the figures in table 4 in mind, one can envisage that by the mid-1990s these costs could at best be halved. Even if thin film technology is able to provide very low cost PV modules by the end of the century, the motor/pump subsystem prices will not be capable of much reduction and the installation costs will remain the same. The absolute limits must be about \$US 1,200 for a 200 Wp system installed, and about \$US 5,000 for a 2 kWp system installed, not adjusted for inflation.

The use to which the solar pump is put will affect the economics. For rural water supply, where the demand is constant, solar pumps are typically competitive with alternatives up to sizes around 1 kWp, except in good wind regimes where a windpump may be better. However, even if the solar pump is slightly more expensive than the alternative, it might be the preferred option because of low running costs and general reliability. The case of irrigation pumping is more problematic. There is a large variation in demand from month to month, so a system sized to meet peak demand will be under-utilized in other months. Even if the cost of a solar pump for irrigation is less than the cost of alternative systems, the investment in the solar pump might still not be justified unless the market value of the crop grown offsets the cost of the pump. For this reason solar pumping is more cost-effective for high value crops requiring low quantities of water, such as fruit. The ability of farmers to pay for solar pumping in the first instance, whether or not it is theoretically economic, is important. Finance in the form of capital grants and low interest loans may be needed. Community arrangements might enable groups of farmers to share the costs and utilization of portable solar pumps because solar pumps are too expensive for small farmers to own individually.

---

## F. Environmental impacts of solar pumping

There is little to say about the environmental impacts of solar pumping. Solar pumping systems are small-scale, so their environmental effects are slight. Some units are portable and they have no permanent effects on the land where they are used. Fixed installations having solar panels, motor-and-pump, and a storage tank occupy no more land than a few small buildings and can easily be incorporated into a village layout. The valuable solar array must, however, be protected from damage by farm animals, vehicles, etc., with a secure fence or wall.

Solar pumping systems are environmentally benign in comparison with systems using other sources of energy. They have less visual impact than wind pumps, and they make far less noise than diesel or biomass engines. Solar systems are also perfectly clean: they produce no fumes or smoke, and there is no need to handle fuels that spill and make the surroundings dirty. The use of solar pumps instead of biomass systems may also help to protect the local environment indirectly by removing one incentive for villagers to take wood and other vegetable matter from forests.

## G. Social aspects of solar pumping

*The social and institutional matrix* within which a solar pumping project operates may be more important than technological factors in determining whether or not the project is successful; different results will be obtained in different locations and communities. Experience in numerous projects, mostly for village water supplies, shows that solar pumping systems are well appreciated by users. In order to ensure the social success of an installation, villagers have to be involved from the beginning. This will impart to the users a full understanding of their responsibilities and motivate their commitment to the project. Villagers should build as much of the local infrastructure as possible themselves (pipes, storage tanks, access, etc.), meeting the cost from their own resources. Technical support and on-going professional advice must generally be brought in from outside.

It is important to ensure that good communications exist between the users and the technical support. If faults in the equipment are not repaired quickly, a negative attitude to the solar system can develop. Sometimes, however, problems occur that give rise to dissatisfaction because they are perceived as failures of the solar system, even though they are not, such as a rise in the demand for water beyond what the system was originally designed to supply, or problems with the distribution of the pumped water.

When a solar pumping system is installed the local community should set up a *management committee* to make decisions on how the water is to be shared equitably, how the expenses associated with the running of the system are to be met, etc. The committee should maintain contacts with professional experts and with commercial suppliers. They will probably have to appoint a caretaker responsible for receiving payments for charges to users, for carrying out routine maintenance, for procuring spare parts and making simple repairs when needed, and for knowing when to call in outside experts to deal with faults that cannot be handled locally.

An early report of the social impact of a solar pump was *the case of the village of Sarwal near Ranchi, Bihar, India*. This village of two hamlets had 350 inhabitants in 66 households, almost all belonging to a native tribe. It was very poor and isolated, without electrification, and with its food production seriously affected by the lack of water outside the monsoon period. These features had determined the choice of the village for the project in 1979, but another factor had been the

availability of technical and administrative support in Ranchi. Planning of the project included studies to ensure that the solar pump would be accepted as a means of improving the life of the entire village. Various difficulties delayed the installation of the pump, but these delays actually served to enhance the involvement of the villagers in the operation, through greater participation in the work, and through a revitalization of the village itself, for example a reopening and enlargement of the village school, the developing of previously neglected land, the setting up of two small shops and the digging of new wells.

The solar pump was a 1.3 kWp PV system capable of pumping 100 m<sup>3</sup> of water per day through a head of 15 m. It was donated by France and was airfreighted by the Indian Government in 1981. The civil work was carried out by the villagers, who were left to make their decisions themselves at their own pace. The commissioning of the pump and the first production of water created great excitement. At first they watered a field above the pump, but later decided that the water must be stored for drinking in a tank at the top of the village. The monsoon would soon bring water to the fields.

The use of the water for irrigation became important in 1982 when the monsoon was so late that there was insufficient water for sowing rice in May-June. The villagers reorganized their farming practices to share land and undertake small-scale dry season irrigation. Some were sent to the regional agricultural training centre, and the project gained official recognition from the regional department officer at Ranchi. Thus irrigation became the main concern, without, however, allowing the drinking water to lose its importance. From 1983 the farmers were for the first time producing dry-season crops: wheat, potatoes, onions, brinjals, chillies, tomatoes, etc.

*A recent case study in Thailand* of a solar-powered pumping system installed in a rural community as a joint venture between a government department and a large Australian manufacturer of photovoltaic panels has provided information on the social impact of the project, including a description of the management system adopted, and how the villagers solved the problems they encountered. The community consists of two villages close to each other situated about 30 km from the nearest town. The combined population of the two villages is about 2,800. The community is served by a government

district office and public facilities (police station, post office, schools, hospital) and the Buddhist temple is their cultural centre. There is electricity and a bus service to the town all day. The traditional occupation of the villagers was rice and cassava farming, but in recent years the rice yield has been very poor because of drought, and many of the villagers now migrate, permanently or temporarily, to obtain other work elsewhere.

Before the installation of the solar-pumped supply, groundwater was the most important source of water for domestic use in the dry season. The water was saline but could be used for washing and for animals. Water was also available from a public pond and a lake, but it was not clear. In the wet season rainwater was important. For drinking, shallow wells were the most important source in the dry season. Most of the households were also able to save about 2 m<sup>3</sup> of rainwater in containers, but by the end of the dry season the majority of the containers were

empty and the people had to rely on water from the shallow wells.

The problems initially identified by the villagers were: first, that the nearest wells, which were 1-2 km away, were privately owned and the water from them had to be purchased, and second, that the public wells, which were 3-4 km distant, were too far away. The villagers were satisfied with the quality of the water from these wells; it was "clear and tasted good".

The solar system was designed to provide drinking water for the community. An investigation revealed a good quality water source at 20 m depth located 2 km outside the village. Because this location was too far away from the main electricity grid, solar energy was the only feasible source of electrical power for pumping. The scheme is illustrated in figure XIII.

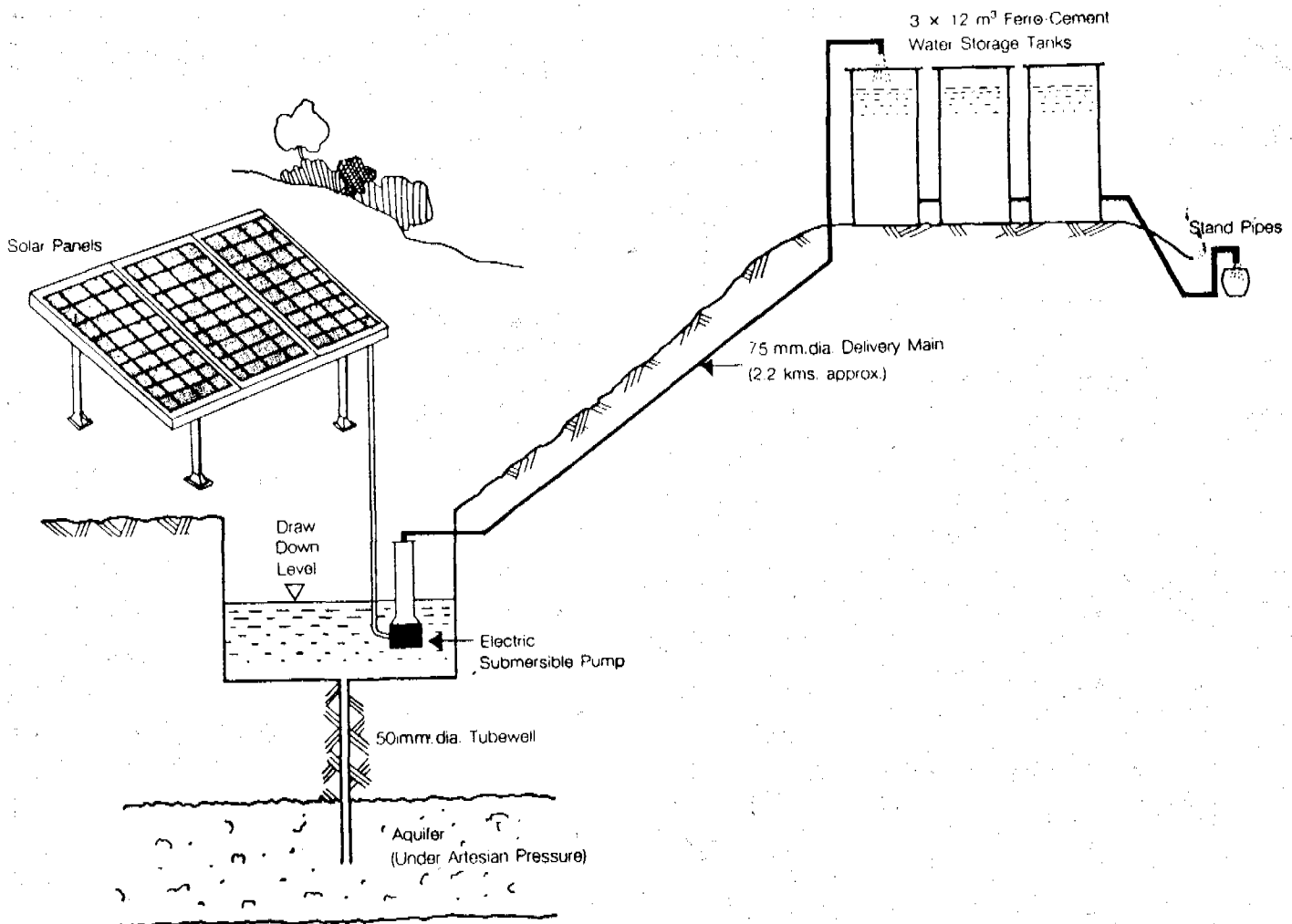

Figure XIII. Water supply system for a village in Thailand

It was found that the village leaders were capable of managing the project. Although the two villages had no prior experience with water systems, they were able to adapt experiences from other development activities to water management. Village labour was used for pipe laying and tank construction, a workable and fair system was established for distributing the water, and a fund was set up to guarantee proper maintenance when external support ceased. After the opening ceremony in March 1988 a village meeting was held in the temple; two caretakers, a financial committee of six, and an accountant were selected for managing and monitoring the project. It had been agreed early in the planning of the project that water from the scheme would be sold at a nominal price. The money received goes to the maintenance fund, out of which the caretakers are paid. In the dry season only one cartload of water can be bought per person; a second cartload can be bought only after all the others have received water in the first round. This system has worked well.

Some unexpected problems were encountered in the project. In the wet season there was a case of a farmer who used the water to irrigate his rice field close to the pump site without permission. Another wet season problem was occasional overflow from the storage tanks. The overflow was channelled into a fish pond and occasionally villagers took water from the fish pond for domestic use.

On one occasion, in the dry season the pipe in the temple was cut by a contractor in order to obtain water for a small building operation, and the water was allowed to run out unchecked while the main system valve was open. As a result other points in the distribution system were deprived of water. A report was made that the pump was not working properly. The engineers called in to solve the problem told the villagers that there was nothing wrong

with the pump, and that a valve should be put on the cut pipe, even though some of the villagers felt that the cut pipe should be left as it was in order to offer some convenience to the monks.

Other problems included persuading one of the caretakers to continue doing the work even though he felt it was not worth the compensation he received, and there were problems keeping the accounts because the accountant could not collect the money from all the subscribers on time.

#### Results of the study and conclusions

- (a) Although the original purpose of the project was to provide drinking water, the water is actually used more for domestic purposes because the villagers do not like the taste of the water. Instead they prefer drinking the water from the open shallow wells (which seems less hygienic).
- (b) The piped water scheme is well accepted for domestic purposes, especially in the dry season.
- (c) People in one area, where the groundwater is more saline, are very satisfied with the alternative water source provided by the solar pump.
- (d) The success of the project depended greatly on the quality of the local leaders acting in liaison between the implementing agencies and the villagers.
- (e) The reliability of the caretakers in enforcing the project regulations and dealing promptly with problems is crucial in the management of the system.

Corrections

Page 21, right column, first paragraph, line 7

For and divide it by substitute by dividing by

Page 37, left column, second paragraph, line 14

After see insert part One,

## H. Advantages and disadvantages of solar pumping

Comments on the advantages and disadvantages of solar pumping are to be found in many places in this report. The present short section serves to bring these comments together in one place for ease of reference and comparison of solar pumping with alternatives. Subsection (c) lists characteristics of solar pumps that are not necessarily advantages or disadvantages, but are nevertheless important when the possibility of using solar pumps is being considered.

### (a) *Advantages of PV solar pumps*

- Present day technology is mature and reliable.
- Systems have a long life (expected to be about 20 years).
- No fuel supplies are needed.
- Maintenance and running costs are low.
- Systems can be operated by unskilled personnel.
- Solar pumps have no bad effects on the environment.
- Output is greatest in sunny weather when water demand is highest.
- PV arrays can be used for other purposes when water demand is low (e.g. in the off-season for irrigation).

### (b) *Disadvantages of PV solar pumps*

- Their high capital cost is too much for individual families and small farmers.
- The system operates only from 8 a.m. to 4 p.m. each day.
- Daily output varies with weather conditions.
- Skilled engineers are needed for maintenance.

### (c) *Other characteristics of PV solar pumps*

- The future trend in solar pumping costs is expected to be down.
- Solar pumping is suitable for low power requirements (200 W to 5 kW).
- Solar pumping is suitable for remote areas with sunny climates (average solar irradiation  $>15 \text{ MJ/m}^2$  per day).
- Systems need monthly check-up maintenance and annual high level back-up support.
- Straightness of boreholes is critical for submerged pumps driven from the surface by a shaft or rod, but not for submerged motor pump sets.
- Surface motors and pumps are more easily maintained than submerged units, which must be withdrawn for maintenance.
- Floating units are suitable for lakes, rivers and shallow wells.

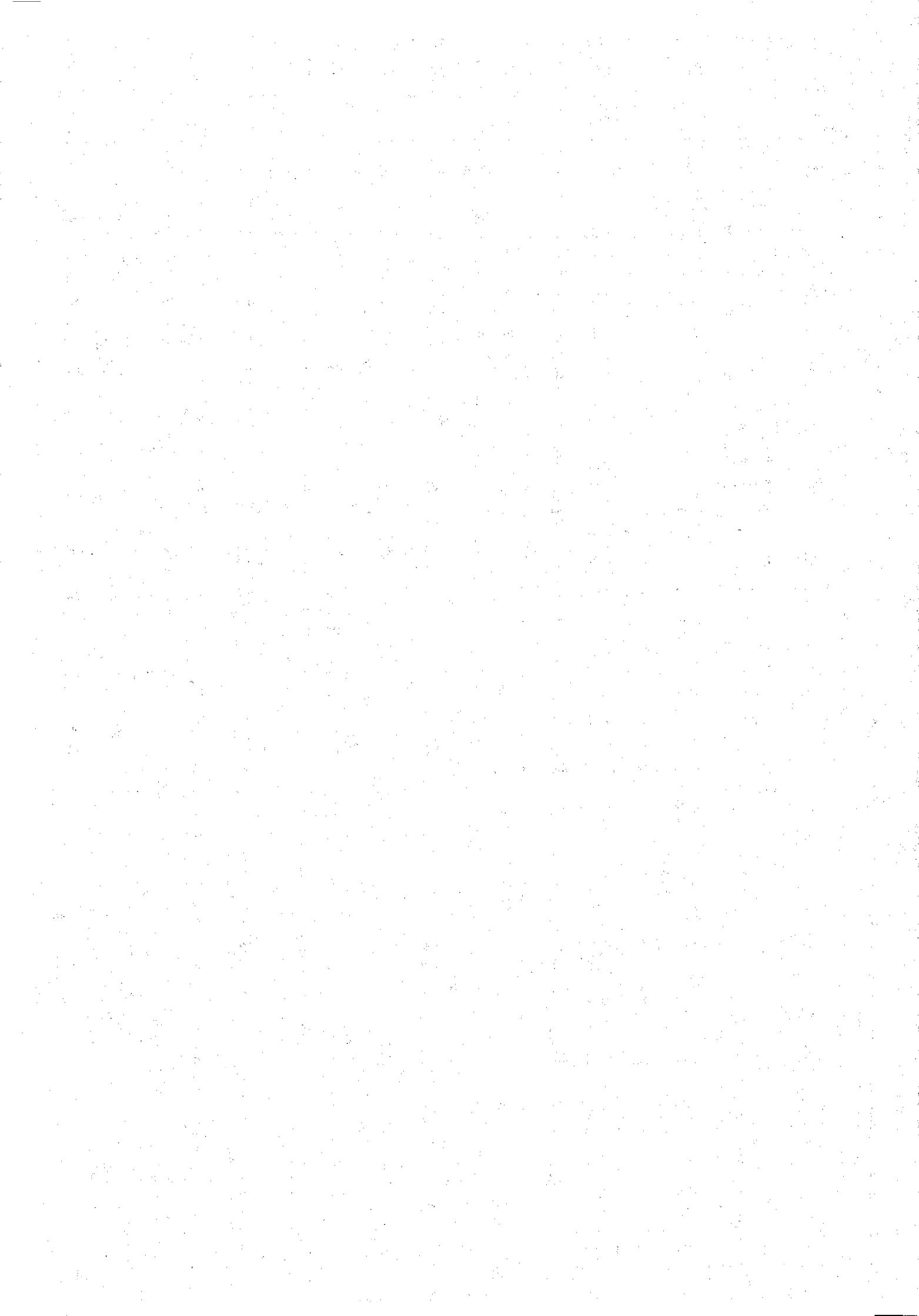



## **Part Two**

### **APPLICATION OF SOLAR PUMPING**



### A. Solar pumping in regions other than ESCAP

The continent of *Africa*, and specifically *Egypt*, enjoys the distinction of having the longest history of solar pumping in the world. It is said that Hero of Alexandria c.100 B.C. made a solar water pump using heated air. Even in the twentieth century Egypt was an early starter: a solar thermal steam pump with an output varying in the range 14-54 kW was built in 1912-13. More recently, at the start of the 1980s, PV pumps for low lift irrigation were tested in Basaisa, an isolated village of 300-400 people in the Nile Delta as part of an on-going integrated field project for introducing new energy technologies to the rural community. The irrigation system in Egypt is complex; in the area of Basaisa, 85 per cent of the pumps were water wheels powered by animals. Several different PV solar pumps were demonstrated in the project. Today at other sites in Egypt there are large deep-well solar pumping systems for irrigation.

*Mali* is another African country where much attention has been given to solar pumping, more than 80 PV pumps having been installed during the 1980s, mostly for village water supplies. The PV pumps were installed under the auspices of charitable and other organizations with financial support from various aid agencies. A detailed appraisal of the solar pumps in Mali, from the technical, economic and social aspects, has been published. It was observed that the technology improved significantly over the study period and that care had to be taken at the design stage to avoid undersizing (with failure to meet the water demand) and oversizing (with additional cost). The systems were economic versus diesel if they were not large (see section E), and continuing institutional support plus well organized local management were both necessary to integrate the solar pumps successfully into the rural communities.

Originally most of the PV pumping systems installed in Mali had submerged pumps and surface-mounted DC motors. There were few problems with the PV arrays, apart from discolouration of the cells and corrosion of the module frames. Most technical problems were associated with the pumps, motors and control systems: wells not vertical, or not deep enough, and insufficient yield of water leading to the pump running dry. A change to AC submerged motor/pump sets has increased reliability. The proportion of time in operation of the more recent systems should be around 95 per cent (i.e. 5 per cent of time lost due to faults). The performance of the PV systems was often below manufacturers' claims, which underlines the need for clear

specification and prior testing before shipment of systems to the sites.

Capital costs of PV pumping systems installed in Mali were found to fall steadily over the study period: a 1.3 kWp system cost \$US 35/Wp in 1979, and \$US 11/Wp in 1988, with \$US 6-10/Wp added for shipping and installation. The ability of local communities to organize themselves and levy charges on users determines their ability to maintain, and even expand, the systems themselves. The cost of maintaining a system is a few hundred dollars (eg. \$US 300) per year.

According to a more recent report there were 157 PV pumping systems in Mali by early 1990, which are very cost competitive in a broad middle range of well depths and water requirements. In terms of the relative life-cycle costs of water, the PV systems have comparable or lower water costs than handpumps, animal traction and diesel pumps for water table depths greater than 15 m in villages with more than 250 persons. Complete PV systems initially cost \$US 35-60 per person (including borehole, storage and distribution) compared with \$US 27-126 per person for handpumps, depending on depth. Families have been willing to make a \$US 100 down payment and annual payments of about \$US 150 for a reliable water source. The most critical need continues to be infrastructure for parts, services and user training. Because of this successful experience, 226 PV water pumps were planned to be added in Mali, and 814 pumps in other areas of the Sahel.

Information from the brochures of commercial manufacturers shows that PV solar pumps are now installed all over the *African continent*. The countries listed by one supplier where five or more of its pumps had been installed by June 1989 are as follows (with number of systems, use, and sponsorship in parentheses):

Algeria	(40, village water, government),
Botswana	(11, water supply, local procurement),
Ethiopia	(38, water supply and irrigation, mostly church aid),
Kenya	(30, water supply and irrigation, foreign aid),
Morocco	(137, water supply, government and aid programmes),
Malawi	(21, water supply, foreign aid),

Mali	(46, mostly water supply, charitable and foreign aid),
Namibia	(9, livestock and wild life),
Niger	(5, water supply, foreign aid),
Somalia	(20, water supply, mostly church aid),
Sudan	(12, mostly water supply, mostly church aid),
Tanzania	(11, mostly water supply, mostly church aid),
Zimbabwe	(5, water supply and livestock, local farmers plus charity).

It has recently been reported (1991) that another manufacturer has been awarded a very large contract for the installation of PV systems in Cape Verde Islands, Gambia, Guinea-Bissau, Mauritania and Senegal. It includes 410 pumping systems, 89 cooling systems, 303 lighting systems and 33 battery charging systems. The combined capacity is 640 kWp.

A few of the solar water pumping projects outside Africa and Asia will be mentioned. Nineteen PV water pumping systems have been installed in the semi-arid region of *Brazil*. The systems range from 420 Wp to 1,400 Wp and supply water for human and animal consumption as well as for agricultural drip irrigation. A unique feature of these projects is that all nineteen systems were entirely designed and manufactured by the Brazilian national PV industry in coordination with the governmental technical agency operating in the Northeastern Region. It is significant that *Brazil's* participation in the "Workshop on Solar Pumping in Developing Countries", held in Manila in June 1981, was an important opportunity to collect information about existing techniques and international experience, especially on borehole PV pumping systems installed in Africa.

Photovoltaic pumping systems have been installed elsewhere in Central and South America. One European company reports having its systems installed in Argentina, Bolivia, Peru and the West Indies. The same company has also supplied 19 systems to *Spain* mostly for irrigation, and 80 systems to the *United States of America* for livestock watering and small-scale irrigation.

An unusual, but interesting, PV pumping system has been installed in Pennsylvania. It is used to solve the problem of watering livestock during the winter when water normally freezes. The barn where the animals are kept is 1km from the electricity grid. Twin 56 Wp PV modules and four deep-cycle lead-acid batteries operate a pump delivering 7.6 m<sup>3</sup>/d from a tank protected from the cold 1.8 m deep under the ground. The system requires only two hours of sunlight per day to recharge the batteries. The significance of this project is that it proves that solar-powered water pumping has an economic future even in the winter in remote areas of the northeast United States.

Over the last four decades *Israel* has pioneered the development of solar energy and its applications. Among its many contributions to the technology the production of electricity from low level heat sources, such as may be obtained in solar ponds, is important. Rankine cycle engines using organic fluids have been linked, through an electrical generator, to a water pump for use in remote areas of *Israel* and elsewhere. In one system, 43 m<sup>2</sup> of flat-plate solar collectors with 16 m<sup>2</sup> of flat mirrors to enhance the radiation falling on the collectors provide heat at 90-125°C to a 600 W turbogenerator driving a pump delivering 11 m<sup>3</sup> of water at a 40 m head per day on the average.

## B. Questionnaire survey on solar pumping in the ESCAP region

*Applications of solar pumping in Asia and the Pacific.* Extracts from the responses to a questionnaire circulated by ESCAP to the countries of the ESCAP region and reported in a note by the Secretariat in 1989 are shown in table 5 to indicate the utilization of solar pumping in Asia and the Pacific. It appears that most of these countries have used solar energy in general applications in pilot/demonstration projects and at a lesser level in commercial activities. Both photovoltaic and thermal processes have been applied. However, less than half of the countries have utilized solar energy for water pumping in the pilot/demonstration projects. Only Australia has reported use of PV-powered water pumping systems at the commercial level and the USSR has mentioned the use of thermal systems. China and Indonesia have utilized solar energy in both PV and thermal applications in pilot/demonstration projects. Malaysia, the Philippines, Thailand, Tonga and Vanuatu have also used PV pumps in such projects.

**Table 5. Utilization of solar water pumping in Asia and the Pacific**

Country/area	Pilot demonstration project	Commercial level	Type of technology
Afghanistan	No	No	
Australia	Yes	Yes	PV
Brunei Darussalam	No	No	
China	Yes	No	PV, Thermal
Guam	No	No	
Hong Kong	No	No	
Indonesia	Yes	No	PV, Thermal
Lao People's Democratic Republic	No	No	
Malaysia	Yes	No	PV
Mongolia	No	No	
New Zealand	No	No	
Niue	No	No	
Philippines	Yes	No	PV
Republic of Korea			
Samoa	No	No	
Singapore	No	No	
Thailand	Yes		PV
Tonga	Yes	No	PV
USSR	Yes	Yes	Thermal
Vanuatu	Yes	No	PV
Viet Nam	No	No	

Source: E/ESCAP/NR. 15/2, 1989.

Although no questionnaire has been returned from Japan, it is known that solar pumping systems have been developed there at the commercial level, particularly for export. Pilot projects and demonstration work have been going on in India where a very large number of solar pumps are now installed.

Thus, although the region is well endowed with solar energy, it appears that this source has not yet been tapped adequately for water pumping purposes. In this respect Asia and the Pacific are lagging behind Africa (see part two, section A above)

*Assessment of prospects for solar pumping applications in Asia and the Pacific.* Table 6 shows the responses to the recent questionnaire on the prospects for solar pumping applications in Asia and the Pacific. Except for New Zealand, all the countries have indicated their interest in the utilization of solar energy for water pumping.

**Table 6. Purposes for which solar water pumping might be considered in Asia and the Pacific**

Country/area	Domestic water supply		Industry and commerce	Irrigated agriculture
	Urban	Rural		
Afghanistan	x	x	x	x
Australia	Solar water pumping is widely utilized			
Brunei Darussalam		x		x
China		x		x
Guam		x		x
Hong Kong		x	x	
Indonesia		x		
Lao People's Democratic Republic		x		x
Malaysia		x		
Mongolia		x		x
New Zealand				
Niue		x		x
Philippines		x	x	x
Republic of Korea		x		
Samoa		x	x	x
Singapore	x		x	
Thailand		x		x
Tonga	x	x		
USSR		x		
Vanuatu		x		
Viet Nam		x		

Source: E/ESCAP/NR. 15/2, 1989.

The major purpose for which solar water pumping appears to have prospects is for rural water supply and, to a lesser degree, for irrigated agriculture. Afghanistan wishes to utilize solar energy for water pumping for all the listed uses. A few countries list urban water supply and industrial and commercial purposes, despite the inability of solar systems to compete in these sectors. It seems more likely that urbanized and industrialized countries would be interested in the production of solar systems for selling to agricultural countries.

The prospects for the application of solar water pumping are very good, although cost considerations limit such applications somewhat at present. Lack of awareness of this maturing technology is doubtless another factor.

According to the completed questionnaire, concerns on various aspects of establishing solar water pumping, were indicated by many countries and areas, as presented in table 7. Most were concerned that the capital cost of purchasing and setting up the systems might be too high. Australia, Hong Kong, Mongolia, Singapore and the USSR did not indicate the capital cost as a major concern. Brunei Darussalam, China, Guam, Indonesia, Niue, Samoa, Singapore and Thailand were of the opinion that using solar technology might not contribute significantly to the overall water supply. Indonesia, Niue and Vanuatu also indicated that both the climatic conditions and the technology might not be appropriate in their case. New Zealand reported unsuitability of the climate for solar energy applications in water development and reported that cheaper alternatives to solar energy were available in the country. The USSR indicated that the climate of its northern regions might not be suitable. Brunei Darussalam and Samoa were concerned about the suitability of the technology.

In addition to the major concern that the capital cost might be too high, a great number of the countries reported lack of trained manpower for the design, manufacture, installation and maintenance of solar water pumping systems. Brunei Darussalam, Guam, Indonesia, Lao People's Democratic Republic, Mongolia, Niue and Thailand indicated a lack of trained manpower for all aspects of related work, whereas Australia, China, Hong Kong, New Zealand, Republic of Korea, Singapore and the USSR reported the availability of the required manpower. Malaysia and the Philippines reported a lack of trained manpower in manufacture of the systems only, and Samoa and Vanuatu indicated no intention to design or manufacture solar pumping systems, and reported a lack of trained personnel for installation and maintenance. There was no report on the manpower situation from Afghanistan, Tonga and Viet Nam.

Information gathered on country requirements for assistance in promoting solar energy applications in water development in Asia and the Pacific is presented in Table 8. According to the responses to the questionnaire, in solar water pumping, the requirements for pilot projects and regional seminars/workshops were indicated by 14 countries, for pertinent guidelines by 12 countries, for assistance through TCDC by 11 countries, and for a technical advisory mission, by 10 countries. Australia, New Zealand and the Republic of Korea did not request any assistance. Hong Kong was interested in receiving pertinent technical and cost information, whereas China indicated interest in a pilot project only.

It is clear that there is much scope for ESCAP to help provide the assistance that these countries require. This topic is discussed in more details later in sections of the present report.

**Table 7. Country concerns in establishing solar water pumping in Asia and the Pacific**

Country/area	Climatic conditions may not be suitable	Technology may not be suitable	Capital cost may be too high	Insignificant contribution to water supply	Lack of trained manpower for system				Remark
					Design	Manu- facture	Instal- lation	Maintenance	
Afghanistan									No report on the subject
Australia									No problems anticipated
Brunei Darussalam		x	x	x	x	x	x	x	
China			x	x					Manpower available
Guam			x	x	x	x	x	x	
Hong Kong									No problems anticipated
Indonesia	x	x	x	x	x	x	x	x	
Lao People's Democratic Republic			x		x	x	x	x	
Malaysia			x		x				
Mongolia					x	x	x	x	
New Zealand	x	x							No manpower problem. Cheaper alternatives to solar application available
Niue	x	x	x	x	x	x	x	x	
Philippines			x			x			Local materials may not be available to manufacture the systems locally
Republic of Korea			x						Manpower available
Samoa		x	x	x	-	-	x	x	No intent to design and manufacture
Singapore				x					Manpower available
Thailand			x	x	x	x	x	x	
Tonga									No report on subject
USSR	Northern regions								Manpower available
Vanuatu	x	x	x		-	-		x	No intent to design and manufacture
Viet Nam			x						No report on manpower

Source: E/ESCAP/NR. 15/2, 1989.

**Table 8. Country requirements for assistance in promoting solar water pumping in Asia and the Pacific**

Country/area	Assistance required in promoting solar energy in water pumping in the form of				
	Regional seminar/ workshops	Pertinent guidelines	Technical advisory mission	Pilot project	Assistance through TCDC
Afghanistan		x	x		x
Australia	No request for assistance				
Brunei Darussalam	x	x	x	x	
China				x	
Guam	x	x	x	x	x
Hong Kong	Technical and cost information requested				
Indonesia	x	x	x	x	x
Lao People's Democratic Republic	x	x	x	x	x
Malaysia	x	x	x	x	x
Mongolia	x			x	x
New Zealand	Cheaper alternatives available				
Niue	x	x	x	x	x
Philippines	x	x	x		x
Republic of Korea					
Samoa	x	x	x	x	x
Singapore	x	x			
Thailand	x	x		x	x
Tonga	x			x	
USSR	x			x	
Vanuatu		x		x	
Viet Nam	x		x	x	x

Source: E/ESCAP/NR. 15/2, 1989.



### C. Notes on selected countries in the ESCAP region

The notes in this chapter give information on countries and projects in the ESCAP region for which interesting information on solar water pumping has been seen in the literature. No attempt has been made to include everything, so the omission of a country, or a project, does not mean that the activity is not important. The principal sources consulted include journals, conference proceedings, a directory of institutions and projects employing photovoltaics in six Asian countries, and a comparative study of energy policies in twelve Asian countries.

#### Australia

The sunny climate and the huge size of Australia, plus the existence of small communities in remote areas far from the main centres of the population make solar energy a potentially attractive option for supplying power in many places in this country. Accordingly, the Australian government is in favour of developing solar and other renewable sources of energy, but not at any price. A major obstacle to the greater use of solar power is its high cost relative to the conventional alternatives such as coal, oil and gas. However, there are no significant social attitudes constraining the use of solar energy, and the concern that Australians show for environmental impacts of development is a positive factor. Australia has long been active in solar energy research, both in government laboratories and in the universities, and the International Solar Energy Society has its Headquarters in Victoria.

Much of the use of solar energy in Australia has been thermal, but photovoltaic systems are widely used for communications. Early field trials of PV systems showed that the balance of plant, rather than the PV arrays themselves, were the major concern as regards reliability. Today, however, it has been reported that solar water pumping is widely utilized in Australia. By mid-1989 one company alone had supplied 115 systems for stock watering to different farming projects, both private and government.

Australian companies are also supplying solar PV pumping systems. They include a large international company with an office in New South Wales, and sales offices in Pakistan, Malaysia, Indonesia, Papua New Guinea and Thailand. The office in Thailand is selling PV panels (not necessarily for water pumping) to surrounding countries, and sales in 1991 will double those of 1990. Another Australian company with its Headquarters in

Victoria and branches all over Australia supplies solar pumping systems in a wide range of configurations and sizes for different purposes such as stock watering, water supply, drip irrigation and low pressure spray systems. Yet another company in Western Australia offers seven standard solar lift pumping kits for stock water, household water, trickle irrigation and water transfer. They range in size and price from 150 Wp at about \$A 4,000 (about \$US 3,000, or \$US 20/Wp) to 500 Wp at about \$A 8,500 (about \$US 6,600, or \$US 13/Wp). These prices, quoted in 1987, do not include transportation and installation. The solar modules carry a 10-year warranty and their expected life is in excess of 25 years.

#### China

The Beijing Solar Energy Research Institute is implementing a PV project in Yihe village, Beijing, in collaboration with Germany. The system is rated at 13.5 kWp and supplies power for basic needs of the villagers, such as communications, television and water pumping (11 kWp). There does not appear to be much interest in solar water pumping in China apart from this project. Wind power is considered to be more cost effective for water pumping in northwest China (Xinjiang and Inner Mongolia). It would seem, however, that if the price of PV systems continues to fall, then there could be a future for solar pumping in China, even under climatic conditions less favourable for solar energy than the conditions in tropical climates; for the climate in China resembles that in the northeast United States where a small PV pumping system has been found to be worthwhile, even in the winter (see part two, section A above).

#### India

The installation of a solar pump in the tribal village of Sarwal near Ranchi, Bihar, and the changes the system induced in the village life in the early 1980s have been described in part one, section G above. It was reported in 1984 that Khandia, another small village in the vicinity of Baroda, Gujarat, chosen because of its obscurity and lack of basic amenities was to become India's first "solar village" with solar and other non-conventional energy sources. The Indian Department of Non-conventional Energy Sources, even at this early date, announced plans for the extensive establishment of PV water pumping units during the Seventh Five-Year Plan. By 1988 the number of PV pumping systems installed in India was over a thousand and by now (1991) it is estimated that

there are more than two thousand solar pumps installed. Financial assistance has come from United Nations agencies (UNDP, FAO) and the government body in charge is the Department of Non-conventional Energy Sources (DNES). There are two large Indian manufacturers producing photovoltaic panels locally, and the pumps are also manufactured by Indian companies. Although PV pumping systems are too expensive for the majority of individuals, they can be afforded by the wealthier persons, and also collectively by communities. There is still a large rural population in remote villages with no access to the main electricity grid and PV pumping could play an important role in meeting the basic demand for water, even though about 80 per cent of Indian villages should by now be electrified and the number of electric pumps for irrigation runs into the millions where they can be used. Although India is capable of manufacturing its own PV modules and pumps, equipment is also being imported from abroad, and a foreign manufacturer has recently been collaborating with the Indian government in establishing service workshops and training for local technicians. During the 1980s the technical aspects of water pumping were often overshadowed by the social and institutional problems; in one case a PV system was chosen, because of a constant history of breakdowns and fuel supply problems with an existing diesel pump. The experiments in India with solar thermal pumps have been mentioned above in part one, section C above.

Foreseeing that renewable energy must supply a significant portion of the Gujarat's anticipated energy needs in the future, the State government is promoting research and applications projects that include the installation of 82 solar photovoltaic pumps even though PV systems are still too expensive to compete with conventional systems there. Other renewable water pumping systems have been installed: 130 water pumping windmills for irrigation and drinking water supply, and 87 gasifier engine pumpsets for irrigation. Experience has shown that if the farmers are unable to handle the technology they go back to diesel pumping. Often they cannot pay the costs of running the systems, so the installation of new technologies must lead to higher incomes of the villagers because agencies cannot give support from external funds indefinitely.

The PV Andhra Pradesh Pumping Demonstration Project had installed twenty PV pumping systems by 1984 and 250 more were planned for the period 1985-90. Each PV system of 300 Wp has provision for manual adjustment of the orientation of the array. Typical site specifications are: area 1.2 ha, lift 5 m, water output 30-40 m<sup>3</sup>/d. The total cost of each system is \$US 2,100. The

whole programme was supported by locally available resources.

## Indonesia

This country has been active in field-testing solar water pumps for some years. A solar water treatment demonstration system was installed in the Kedung village of West Java in 1986, which included a PV pump. There are the five thermal solar pumping systems mentioned in part one, section C above, and twenty PV pumping projects were listed in 1987. The PV projects cover a wide geographical area, ranging from Irian Jaya (near Merauke) in the east to Sumatra in the west, with important projects on Java and Sumba. They have been supported by the Government and by foreign aid. Most of them are for village water supplies of 5-25 m<sup>3</sup>/d with PV arrays rated at 1-2 kWp; but there is an important irrigation project pumping 250 m<sup>3</sup>/d with a PV array rated at 5.5 kWp in Java. By 1984 only 22 per cent of the villages in Indonesia had been electrified. It is planned to increase this to 47 per cent by 1994. Even then, the need for other sources of electricity besides the power grid will remain large for a long time to come and PV could help to fill the need. In some places villagers must walk very long distances to obtain water (15-20 km have been reported). The provision of wells with solar pumps would allow these people to make better use of their time and energy.

The Indonesian PV agricultural pumping demonstration system was installed in a small village, Picon, near Serang, West Java, in 1979. The 5.5 kWp PV array drives an AC pump set through an inverter. An average water output of 250 m<sup>3</sup>/d was reported. In 1981 the installation was damaged by floods 1.8 m deep (caused by heavy rainfall) and the system was modified several times thereafter. The modifications included changing the inverter and replacing the PV modules by a newly developed type after the old modules had been found to deteriorate due to internal discoloration.

Three village water supply PV pumping demonstration projects were installed on the Indonesian island of Sumba at Gollowatu, Pemuda and Wee Muu in 1982-83. The system in Gollowatu operated with two DC pumps (one borehole eccentric pump and one centrifugal pump) driven by a 5.76 kWp PV array. It was used to deliver drinking water from a 28 m deep subterranean river for about 6,000 people. After installation both DC motors failed and had to be replaced, and the shaft of the eccentric pump broke several times. In 1987 the system was changed to an AC one with a higher capacity, which worked well. Pemuda and Wee Muu each had 3.65 kWp PV arrays and submersible AC pumps providing drinking

water for 2,000 people. The systems have worked satisfactorily apart from minor faults with the inverters, which are now corrected. The system in Pemuda has since been enlarged.

### Japan

Although Japan does not appear to be using solar pumps within the country, it is well known as a leading manufacturer of PV modules and solar pumping systems in the region.

### Malaysia

A single-phase submersible pump for pumping 36 l/min through a total head of 55 m and powered by a PV array of 3.7 kWp has been installed in a village in Perlis. Trapezoidal mirrors double the solar irradiance in the array, whose orientation is adjusted periodically. The system has been operating satisfactorily without any major breakdown. Research on the project is being carried out at the University of Science of Malaysia in Penang. It is expected that 75 per cent of the rural population in Peninsular Malaysia will have access to electricity by 1990. In Sarawak only 53 per cent of the population is estimated to have access to electricity; so this area could probably benefit significantly from solar water pumping.

### Federated States of Micronesia

The Micronesian Mariculture Demonstration Center in the Republic of Palau has, with the help of foreign aid and expertise, designed and constructed a PV solar seawater pumping system for use in giant clam mariculture. Because the clams are dormant at night and the photosynthetic process is shut down, solar electricity seems to be the perfect match. During sunlight hours, when algal cells inside the clams are photosynthesizing, unfiltered lagoon water is pumped through the hatchery tanks to supply nourishment, remove wastes and prevent potentially lethal overheating. Eight 43 Wp modules provide the power. Major components of the plant are not experiencing seawater corrosion and the only maintenance required is periodic inspection of the pump motor for normal wear. It has been suggested that serious consideration should be given to the use of solar power for seawater pumping systems elsewhere in Micronesia.

### Nepal

It is known from commercial brochures that PV pumps have been installed for pumping drinking water from boreholes in Nepal. The limited development of

rural electrification and the nature of the terrain would appear to make this country typical of those for which solar pumping systems would be valuable. An experimental solar PV panel providing energy for pumping water in Nepal was illustrated in a publication of the FAO in 1990, and there is a very large project in that country for installing PV systems at the present time.

### Pakistan

In the early 1980s photovoltaic pumping systems for irrigation were installed in Pakistan by international agencies with the objective of demonstrating, testing and evaluating the suitability of this technology for the needs of rural people. It has been estimated that about half a million pumps could be used in Pakistan, where 44 per cent of the farmers own 1-3 ha of land. These small farmers would be interested in the technology for lifting 100-300 l/min of water from depths of 2-5 m below the ground, although high cost is still a barrier. One young farmer with 5 ha of land completely replaced his animal-driven Persian wheel pump with a solar pump during the trials. Studies of the cost of water pumping with solar PV units compared with wind, petrol engines, solar thermal and grid-connected electricity suggested that solar PV pumping might fit into the low-volume low-lift category for use in remote areas.

An economic assessment of PV programs, applications and markets in Pakistan published by the World Bank in 1989 indicated that the use of PV in many applications was economically justified, even at current costs and with commercially available technology. This was true for health clinics, household power supply and telecommunications. However, PV pumping systems (at PV module costs of \$US 6/Wp) were not economically competitive in Pakistan with diesel pumps or handpumps for village water supply, except in cases of high heads or larger settlements where maintenance and diesel fuel supply would be difficult. However, at reduced module costs (\$US 3Wp) PV pumps would have a niche for settlements of 50-500 people, depending on pumping head and insolation. In the case of irrigation, in the Punjab where the study was made, even under the best conditions (low PV costs, high diesel fuel costs and poor diesel pump efficiency), PV pumping would be cost-competitive with diesel pumping only for small farms of up to about one hectare. Because the small farmers could rent diesel pump sets, or buy water, more cheaply than using PV, the near term prospects for solar irrigation pumps were not good. PV pumping would not be viable for drainage compared with diesel and electrical pumping due to the large discharges required.

The 1989 World Bank report on Pakistan recommended that, because village water supplies need highly reliable equipment and fuel supply, solar pumps would be justified for villages in areas where the operation, maintenance and fuel supplies of diesel engines were unreliable, even for larger villages than economic considerations indicate. It would be useful for the Government to undertake field testing to ensure reliability of the PV pumping systems, and to identify appropriate sites for such systems. The report also recommended that it would be worthwhile for a systematic monitoring of recent solar pumping technology and diesel pumps to be made, with particular emphasis on farming practices and water application methods needed to make PV pumping competitive. Tests in different regions besides the Punjab should be made, since the competitiveness of PV pumping is very sensitive to cropping patterns.

The economic market size for PV pumping in Pakistan estimated by the 1989 World Bank report was 165 kWp for village water supplies and 10 kWp for irrigation pumping over five years (1989-1994), assuming a price of \$US 6/Wp. If the module price were reduced to \$US 3/Wp, the market size in five years was estimated at 750 kWp for village water supplies, but still only 10 kWp for irrigation.

### Philippines

A number of PV demonstration projects that included water pumping were conducted in the Philippines in the 1980s. The project in Talampas, Talaksan, funded by UNDP with the cooperation of the World Bank, was for testing small-scale solar-powered irrigation pumping systems. In Cebu Province a potable water pumping project assessed the suitability of solar-powered pumping systems for providing the water needs of rural communities in the Philippines. Other projects have included water pumping as components of the load in PV power systems for villages. The Republic of the Philippines is an archipelago of some 7,000 islands, out of which 2,300 are inhabited and only 27 are electrified. For this reason there are serious plans for the use of PV systems, several hundred of which will by now have been installed, with drinking water supply as an important use of the electrical power.

### Sri Lanka

This country is well known for having the first ever pilot project on developing an integrated rural energy centre. The Sri Lankan Rural Energy Centre was initiated in 1976 and was fully commissioned in 1980 at Pattiapola village a few kilometres inland from the

southern tip of the island. It was sponsored by UNEP with foreign costs provided by UNEP and local costs provided by the Sri Lankan Government. The short term objective of the project was to study, on an experimental basis, the possibility of harnessing locally available renewable sources of energy and to determine the socio-economic impact that this would have on the rural populations.

Most of the villagers in Pattiapola obtained their drinking water from open wells scattered around the village, or from the village reservoir. The quality of the water was poor and was susceptible to contamination with organic pollutants. The equipment in the Rural Energy Centre included a 2 kWp PV array whose output was used, among other things, for water pumping. The whole energy system is shown in figure XIV. Thus one of the benefits of the project to villagers was a better supply of drinking water. The water supply system at the Centre included a tube-well as source, a water purification facility, and storage.

The facilities provided in the village have improved the life of the people there, but the system is not economic as it was set up at a time when renewable energy technologies were first appearing. Now the availability of grid-based electricity in certain nearby villages with 24-hour supply and lower cost brings about a certain amount of concern. The people are, however, better off than those who live in the thousands of other villages of Sri Lanka who do not have access to any electricity at all. Experience from this project indicates that careful prior study of all the factors involved, both technical and social, and planning so as to help the poorest section of the society with efficient and reliable energy systems, are needed in such undertakings.

### Thailand

In 1986 80 per cent of rural villages were connected to the main electricity grid, and it is planned to have all the villages (i.e. 100 per cent) connected by 1997. For this reason interest in photovoltaics in Thailand has been limited to remote navigation and telecommunications installations. There has, however, been some research done on solar pumping in universities and government research establishments. Here is a list of the solar pumping projects in the field:

- (a) Si Chang Island, 1-5 kWp for plankton cultivation, funded by Chulalongkorn University.
- (b) Ban Tha-yien village, Sakon Nakhon

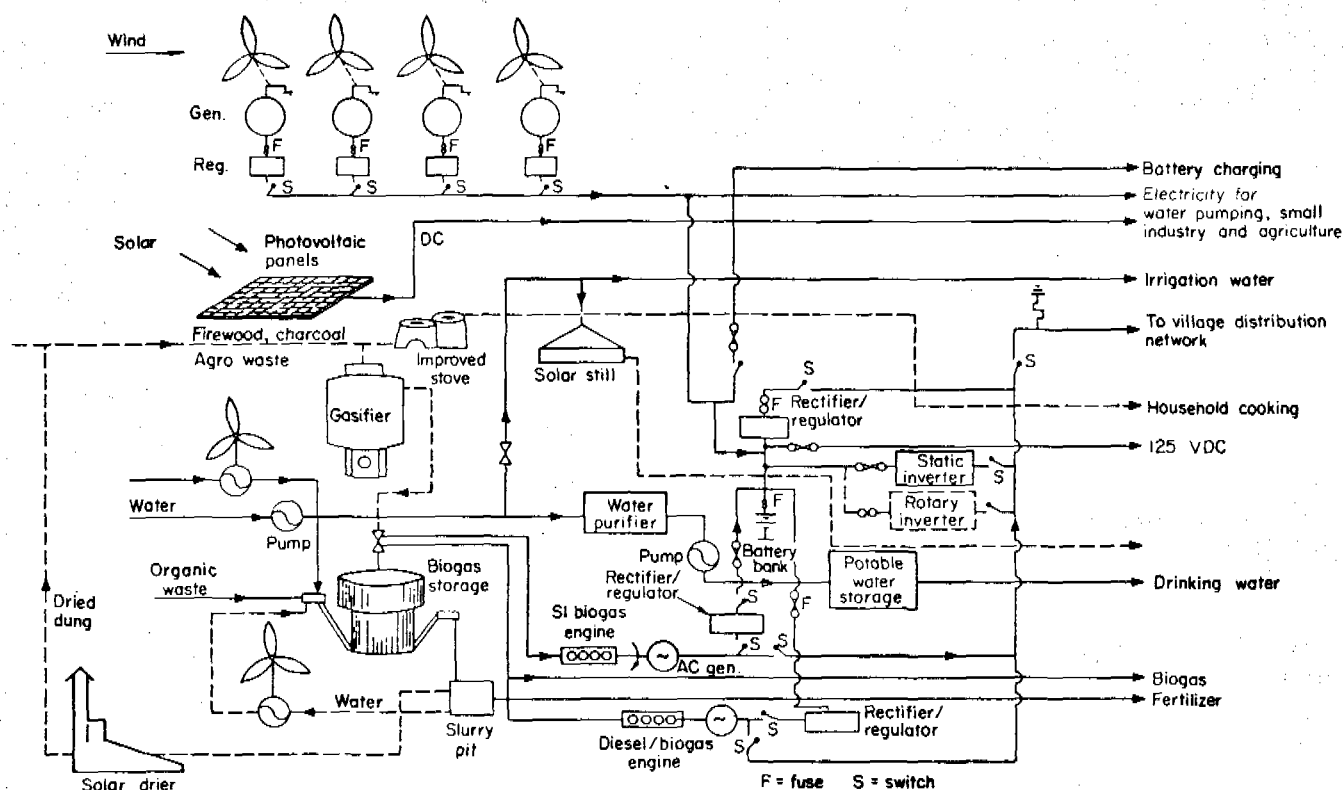

Figure XIV. Integrated rural energy centre in Sri Lanka

Source: ElMahgary, Y. and A.K. Biswas, 1985.

- Province, 720 Wp for domestic water supply, with foreign aid.
- (c) Maharakam Province, 259 Wp for irrigation and to circulate water in a fish pond, funded by the Government.
- (d) Phra Yuen, Khon Kaen Province, 630 Wp for village water supply, commercially funded. This is the project whose social aspects were described above in part one, section G. Solar PV pumping was chosen because the location of the water source was too far away from the main electricity grid for the use of ordinary electrical pumping. The ability of the villagers to manage the project themselves was a crucial factor in the success of the project.
- (e) Khao Hin Son, Royal Development Study Centre, for irrigation in orchards.
- (f) King Mongkut's Institute of Technology Thonburi, has undertaken some field research in solar pumping.

- (g) The Asian Institute of Technology, near Bangkok, has an "Energy Park" containing demonstration and testing facilities for solar PV panels and solar water pumps, several varieties of which are on display.

*In conclusion* it may be noted that there has been much more attention given to solar pumping in Africa than in Asia and the Pacific. Two reasons may be advanced as possible explanations of this. First, the countries of Africa are generally drier than those of Asia (some extremely so around the Sahara desert) and the problem of water supplies is more acute in Africa than in Asia. Second, the attention of European manufacturers and international aid agencies has been more on Africa than on Asia for both historical and geographical reasons. In comparison with Africa, the countries of Asia and the Pacific have wetter climates and water is less of a problem, except in the dryer areas of the region towards the Middle East, and in central Australia. Consequently, the introduction of solar pumping technologies has been slower in Asia and the Pacific than in Africa.

## D. International cooperation through ESCAP in the promotion of solar pumping

The purpose of this chapter is to discuss the role that ESCAP might play in the promotion of solar water pumping in the region. This will be done in the light of the status of solar water pumping in the world today and the needs of the various countries of the region. An overview of the status of solar water pumping from the points of view of economics, technology, and social factors has been given in Part one, while information on the actual application of solar pumping in the world today has been given in the previous chapters in Part two.

The sorts of actions that ESCAP might take are suggested by the *Proceedings of the High-Level Regional Consultative Meeting for the Mobilization of Financial Resources for New and Renewable Sources of Energy and of the Meeting of Focal Points on New and Renewable Sources of Energy*. However, there are two differences between the circumstances that gave rise to those proceedings and the circumstances under which this report is being prepared. First, those meetings covered the wider scope of renewable energy in general, whereas this report is restricted to solar energy, and within solar energy to the subject of water pumping. Second, at the time of those meetings in 1984 the technology of solar water pumping was unreliable and very expensive. Today reliable solar water pumping systems are available on the market at lower prices than before, and the prices are still falling gradually. Solar water pumping is on the edge of economic viability. Indeed, PV pumping is cost effective and the preferred choice against alternatives in certain circumstances. Therefore, differences can be expected to exist between what ESCAP was recommended to do in 1984, and what ESCAP is likely to consider it should do today.

The activities recommended to ESCAP were divided into six broad areas.

- (a) *Energy assessment and planning:* activities envisaged included studies for producing and publishing a data base, and for training in data collection and analysis. This was to include studies of demand-supply and socio-economic aspects. In the case of solar pumping, the resource data base (solar irradiation) is now rather well known in the ESCAP region, and adequate estimates of it can be compiled from existing information. The need to launch large solar irradiation measurement programmes has probably passed, since satellite climatology will give

the main features of the resource in the region. What is required, then, is for ESCAP to identify researchers and help arrange funding, if necessary, for producing the required publication of data. Studies of the demand-supply and socio-economic aspects of solar pumping are currently being made by manufacturers because they believe that solar pumping is developing into a growth market for their products. ESCAP should monitor these studies and help to increase awareness and contact between suppliers and users of the solar pumping systems.

- (b) *Research, development and demonstration:* the approach suggested then was to promote the establishment of networks of R, D, and D institutions to coordinate efforts in this area. Today it is hard to see what R, D, and D institutions of the region can do that is not already being done by the manufacturers of solar pumping systems. What is happening at the moment in the region is that manufacturers are supplying technology that has already been developed and demonstrated. Many countries appear to be passing from a phase that needed external financial support, because the users could not afford to pay for the technology, to a phase in which the users (government or private) will find it economic to buy solar pumping systems when conditions are appropriate. Such cases should be recorded by ESCAP, and information on them should be made available to other parties interested in solar pumping. These parties could then learn what can be done by visiting the project sites.
- (c) *Transfer, adaptation and application of mature technologies:* two activities were proposed under this heading: the organization of a meeting of those interested in the transfer of mature technologies, and the commissioning of a study of the policy measures and implementation strategies needed to accelerate the use of existing technologies in individual ESCAP countries. Both of these proposed activities are still appropriate today. The proposed meeting would include government officials,

manufacturers of solar pumping equipment and entrepreneurs to identify specific constraints on the transfer of solar pumping technologies and suggest ways and means of removing them, such as the introduction of incentives and subsidies to indigenous manufacturers and users, financing arrangements, and the creation of public awareness of the technology. The proposed study (to which the present report is a contribution) should give a status report on solar pumping and an assessment of its relevance and suitability in countries of the ESCAP region.

- (d) *Information flows:* it was felt earlier that information on new and renewable energy activities in the region and elsewhere was scanty. A variety of different types of publication were envisaged, which included: review papers on the state-of-the-art, handbooks and leaflets on the application of the technologies, directories of personnel in institutions engaged in new and renewable energy activities, and regular newsletters. The situation today, however, is different. In the case of solar pumping there is now plenty of information published, and the task today is selecting what is useful and bringing it all together. This important task is, of course, time-consuming and expensive. Attention must be directed to the type of information needed, which today is on manufactured products and prices rather than on researchers and institutions in the region. The information must be supplied to the users, who are those persons, government or private, responsible for the provision of water supplies in locations where solar energy might be a better option than other sources of energy. ESCAP could examine whether it should undertake this on-going work itself, or should identify another agency to do it with the help of funds raised for this purpose. There are good handbooks available for explaining solar pumping systems, and there are simple guidelines and detailed computer packages for designing solar pumping systems in specific applications.

- (e) *Education and training:* this is an important factor in the development of any technology, especially solar pumping, which requires an adequate supply of people who

*understand the systems and are capable of*

- making preliminary assessments of the type, size and cost of solar pumping systems appropriate for specific uses in the field,
- installing, operating and maintaining solar pumping systems, and
- correcting faults and knowing when to call in expert help for repairs, replacements or system modifications.

ESCAP would be able to assist by supporting or helping to organize training programmes for such personnel actively involved in the installation and use of solar pumping systems.

*Training courses of this type have been conducted under the UNDP/World Bank Project. For example a five-week training course on photovoltaics and solar powered pumping systems for engineers held in 1985 had as its objectives:*

- To reinforce the knowledge of the participants in the principles of solar energy and photovoltaic conversion with specific reference to solar pumps.
- To review the main applications of photovoltaics.
- To establish an understanding of alternative solar pump types.
- To consider installation, operation and maintenance requirements of solar pumps.
- To review solar pump test procedures and establish an understanding of instrumentation and calibration methods for solar pump testing.
- To obtain and analyse test results for (i) PV arrays, (ii) high head submersible solar pumps and/or (iii) medium head surface mounted solar pumps.
- To establish an understanding of the methods of economic analysis.
- To allow participants to become conversant with undertaking economic case studies on solar pumping systems.
- To review solar pump purchasing procedures, including tender documents and pump selection procedures.

- To learn the essentials of planning and implementing a field trial programme.

Another course intended for the basic training of technicians was conducted in 1988. It included the following topics: the solar photovoltaic system, electricity, wire sizing, photovoltaic panels, batteries, pumping systems, and the maintenance of PV systems.

Manufacturers of educational laboratory equipment are now producing *test stands for teaching solar energy*. For example, a European firm is advertising a solar pump system that enables students to analyze the interdependence of a solar PV generator (two modules 36 V, 0.5 A), a drive motor (DC shunt type excited by a permanent magnet) and a centrifugal pump. The motor is fed from the solar PV generator directly without intermediate battery storage. The parameters that can be adjusted by control

units are the radiation intensity (simulated by two 1000 W lamps), the motor speed, the discharge pressure, and the discharge flow. It might be useful for ESCAP to disseminate information on products such as this to universities in the region, and if possible to assist these universities financially to acquire the equipment for educational purposes.

- (f) *Mobilization of financial resources.* It was noted in the earlier meetings that additional financial resources over and above those available in the United Nations budget system would be needed for the regional projects in renewable sources of energy. The sources of such funds might be donor agencies, but today as solar pumping approaches economic viability, other sources of funds from industry, governments and private users might become increasingly important.



**Part Three**  
**CONCLUSIONS AND RECOMMENDATIONS**



## A. Conclusions

Most of the developing countries in the ESCAP region lie between 35° N and 35° S, in an area which receives the highest concentration of solar energy. Although the region is well endowed with solar energy it appears that this source has not yet been tapped extensively for water pumping purposes. During the 1980s Asia and the Pacific lagged behind Africa in the utilization of solar energy for water pumping.

Solar pumps are most suitable for use when there is little variation between peak demand and the average annual demand while irradiation is high and does not vary greatly from month to month. This is true throughout the ESCAP region, except in a few areas such as Southern China, the islands of Indonesia along the equator and the extreme south of Australia and New Zealand. Nevertheless, the use of solar pumps is expanding in Indonesia.

Solar pumps appear to be economically more viable for village water supplies and livestock watering than for irrigation since people are prepared to pay higher prices per cubic metre for drinking water in the relatively small quantities involved.

If solar-powered water pumping is used in irrigation, it is more suitable for smaller farms growing cash crops and requiring irrigation throughout most of the year. In such cases short-term storage of water would give the farmer improved water control and would smooth out day-to-day variations in the water supply from the solar powered system. In other types of farming, long-term storage of water may be necessary requiring rather costly storage facilities; this is not feasible with solar pumping.

Many countries are now using solar water pumping in pilot projects or at the commercial level and there is significant interest, in the region, in the application of solar energy to water pumping, particularly in the provision of rural water supplies.

Both solar thermal and solar photovoltaic pumps are technically feasible, but, although some solar thermal systems have been successfully demonstrated, solar PV systems are the only types in general use. PV solar pumping technology is now a mature and reliable

technology, and many different models are available on the market.

Prospects for the application of solar water pumping are high in the Asia and Pacific region where it has been estimated that 100 million pumps are required. The suitability of the climate, with high solar radiation rates all the year round in most parts of the region, suggests that a significant number of these pumps could be powered by solar energy. The total solar PV requirement for pumping in Asia has been estimated at about 25 MWp.

The present costs of solar pumping systems are high (\$US 1,000 - \$US 20,000, depending on size) although they are comparable to the costs of fuel-powered systems in remote areas and islands for the provision of drinking and domestic water supplies. It is probable that, with the reduction of the cost of PV arrays and with fuel prices increasing, solar-powered water pumping will become a viable alternative in areas with adequate year-round irradiation. Tax incentives by governments would also serve to increase the use of photovoltaics.

For each individual application of a PV solar-powered water pumping system correct sizing of the components is important, and the economic viability must be ascertained taking into consideration local conditions and the cost of alternatives, including wind-powered, fuel-powered and electric pumps.

For the promotion of solar pumps, and for their successful application, the public must be made familiar with their use. Publicity campaigns and commercial advertising may serve this purpose. The required skills for operation and maintenance could be imparted through training courses to the people who will be involved in operating the pumps.

When a solar pumping system is provided to a community with government or institutional support it is essential that the users should be involved throughout, from the planning stage onwards, and that workable arrangements are made for the users to manage the operation of the system themselves and take action, as necessary, to have faults corrected promptly.

## B. Recommendations

The recommendations are divided into three broad categories:

- (a) *The dissemination of technical information on solar pumping.* A number of handbooks and manuals containing technical information on solar pumping, including methods of selecting the size and type of PV systems, economic evaluation of these systems, and testing their performance are available. These manuals should be kept up-to-date and should be widely advertised and distributed through the regular channels of publication.

Existing data from ground observations and global satellite surveys should be analyzed to produce up-to-date solar radiation climatologies for the region. The areas susceptible to typhoons and floods should be screened so that valuable equipment should not be installed in places where it would be prone to frequent damage.

Market surveys of the demand/supply and socio-economic aspects of solar pumping applications made by manufacturers should be monitored and published where possible.

- (b) *The exchange of data and experiences between suppliers of solar pumping systems and users in the region.* Information on the solar pumping equipment and systems available on the market should be compiled and made available in the region by the publication of a directory of manufacturers, agents, equipment and services. This will include firms outside the region as well as firms located within the region.

In cases in the region where the solar option has been chosen for water pumping at the commercial level, or in demonstration projects, data on the cost, installation and operation of the systems should be recorded and made available to other parties interested in solar pumping.

Meetings should be organized to bring together government officials, manufacturers and users, to display the technology in exhibitions, and to discuss ways and means of heightening awareness of solar pumping technology and promoting its use in the region. Manufacturers of solar pumping systems should be approached for advice and support in this work. Government agencies should establish contacts with the private sector and reduce taxes on solar panels.

- (c) *Training and education.* Training programmes on the installation, operation and maintenance of solar pumping systems should be organized and supported. The ESCAP regional network for training in water resources development could be used for this purpose.

Information on commercially available test stands for the teaching of solar pumping technology in universities and technical institutes should be collected and disseminated. Universities and technical institutes should be given assistance in the acquisition of teaching equipment such as this.

## Bibliography

The following is a list of publications covering the general subject area of solar water pumping which have provided much of the basic material for the present report.

1. ElMahgary, Y and Biswas, A.K. *Integrated Rural Energy Planning*. Butterworth, England, for UNEP and International Soc. for Ecological Modelling, 1985.
  2. ESCAP Secretariat. *Assessment of Experience in Application of Solar and Wind Energies in Water Resources Development and Prospects for Application in the Region*. Paper No. E/ESCAP/NR.15/2, 1989. [For the Fifteenth Session of the Committee on Natural Resources and Energy in Bangkok, 9-13 October 1989.]
  3. Hofkes, E.H. and Visscher, J.T. *Renewable Energy Sources for Rural Water Supply*. Technical Paper 23, International Reference Centre for Community Water Supply and Sanitation, The Hague, The Netherlands, 1986. [Provides guidance and information to support the systematic consideration of various renewable energy sources and devices for rural water supply pumping.]
  4. I.T. Power. *Solar Powered Pumping Systems: Their Performance, Cost and Economics*. Ref: 85190. Reading, UK and Washington DC, USA, 1986. [A report prepared for the World Bank.]
  5. Kenna, J. and Gillett, B. *Solar Water Pumping: A Handbook*. Intermediate Technology Publications, London, 1985. [A practical introduction to solar water pumping.]
  6. Lucas, N. J. D., Ambali, J., Chang, E., Forbes-Ricarte, M. S. and Shrestha, R. M. *Energy Policies in Asia: A Comparative Study*. McGraw-Hill, 1987.
  7. McNelis, B., Derrick, A. and Starr, M. *Solar-Powered Electricity: A Survey of Photovoltaic Power in Developing Countries*. I.T. Publication, UK, in association with UNESCO, 1988. [Covers water pumping, refrigeration, lighting, rural electrification and other applications, with recommendations taking into account technical, economic, social and institutional factors.]
  8. United Nations. ESCAP Secretariat *Regional New and Renewable Sources of Energy. Development Programme for Asia and the Pacific*. Publication No. ST/ESCAP/345, 1985. [Proceedings of the High-Level Regional Consultative Meeting for the Mobilization of Financial Resources for New and Renewable Sources of Energy and of the Meeting of Focal Points on New and Renewable Sources of Energy].
  9. Sir William Halcrow and Partners and Intermediate Technology Power Ltd. *Small-Scale Solar-Powered Pumping Systems: The Technology, its Economics and Advancement*. Main Report. UK, 1983. [Describes the work which the consultants undertook for the World Bank in the period 1981-83 as part of UNDP Project GLO/80/003 to test and demonstrate renewable energy technologies.]
- Besides the above publications, the conference proceedings and periodicals listed below have been searched for information. Miscellaneous papers, articles, unpublished reports, company brochures and advertising literature have also yielded data on individual projects and manufactured equipment.
10. Bloss, W.H. and Pfisterer, F. (Editors). *Advances in Solar Energy Technology*. Pergamon, 1988.
  11. Sayigh, A.A.M. (Editor). *Energy and the Environment into the 1990s*. Pergamon, 1990.
  12. *RERIC News*. Asian Institute of Technology.
  13. *Renewable Energy Review Journal, and RERIC International Energy Journal*. Asian Institute of Technology.
  14. *Solar Energy*. Pergamon.
  15. *Sunworld*. International Solar Energy Society.