

2 3 2 . 5

8 6 P R

**IDRC-MR102eR**

International Development Research Centre

# MANUSCRIPT REPORT

## **Proceedings of a Workshop on Hydraulic Ram Pump (Hydram) Technology**

**February 1986**



232.5-86PR-5783

The International Development Research Centre is a public corporation created by the Parliament of Canada in 1970 to support research designed to adapt science and technology to the needs of developing countries. The Centre's activity is concentrated in five sectors: agriculture, food and nutrition sciences; health sciences; information sciences; social sciences; and communications. IDRC is financed solely by the Parliament of Canada; its policies, however, are set by an international Board of Governors. The Centre's headquarters are in Ottawa, Canada. Regional offices are located in Africa, Asia, Latin America, and the Middle East.

#### **IDRC Manuscript Report**

**This series includes meeting documents, internal reports, and preliminary technical documents that may later form the basis of a formal publication. A Manuscript Report is given a small distribution to a highly specialized audience.**

IDRC-MR102eR

5763  
239.5 86PR. 2<sup>nd</sup> copy.

PROCEEDINGS OF A WORKSHOP ON  
HYDRAULIC RAM PUMP (HYDRAM) TECHNOLOGY

HELD AT ARUSHA, TANZANIA

MAY 29 - JUNE 1, 1984

ORGANIZERS:

- CENTRE FOR AGRICULTURAL MECHANIZATION  
AND RURAL TECHNOLOGY (CAMARTEC)  
ARUSHA, TANZANIA
- INTERNATIONAL DEVELOPMENT RESEARCH CENTRE (IDRC)  
OTTAWA, CANADA

Technical Editor: Eric J. Schiller

Material contained in this report is produced as submitted and has not been subjected to peer review or rigorous editing by IDRC Communications Division staff.

Mention of proprietary names does not constitute endorsement of the product and is given only for information.



	<u>CONTENTS</u>	<u>PAGE</u>
<b>FOREWORD</b>	A.B. Redekopp	4
<b>WORKSHOP CONCLUSIONS AND RECOMMENDATIONS FOR ACTION</b>		6
<b>OPENING ADDRESS</b>	E.M. Ngaiya	9
<b>INTRODUCTION</b>		
The Hydraulic Ram Pump (Hydram): Its History, Operating Characteristics and Potential Use	E.J. Schiller	11
<b>COUNTRY PAPERS</b>		
The Application of Hydram Pumps in Rural Water Supply Schemes in Tanzania	A. Mzee	24
The Use of Hydrams for Water Pumping in Tanzania	D. Tulepona	28
The Hydraulic Ram Pump in Kenya	Oyuko O. Mbeche	34
The Hydraulic Ram Pump Technology and Practice in Zambia	W.T. Weerakoon & V. Liyanage	37
<b>MANUFACTURE, OPERATION AND MAINTENANCE</b>		
Practical Aspects of Hydram Operation	E.J. Schiller	54
The Manufacture of Hydrams	S.S. Jandu	59
<b>COMMUNITY PARTICIPATION</b>		
Community Participation and the Development of Hydrams in Rural Water Schemes	L.G. Msimbe	62

<u>CONTENTS (Continued)</u>		PAGE
Socio-economic Considerations in Rural Water Supply Development	W. Baynit	66
<b>RESEARCH NEEDS</b>		
The Theory and Design of the Automatic Hydraulic Ram Pump	P.O. Kahangire	71
Hydraulic Rams as Potential Pumping Units for Rural Water Supply Schemes in Tanzania	T.S.A. Mbwette and E.Th.P. Protzen	100
<b>LIST OF PARTICIPANTS</b>		120

## FOREWORD

Providing adequate domestic water supplies for scattered rural populations poses a major problem to many developing countries. Sparsely populated settlements cannot be easily served by conventional piped water systems. In addition, the fuel and maintenance costs of operating a conventional pumping system using diesel or gasoline engines are becoming prohibitive for many developing countries. The hydraulic ram pump (hydrum) is a simple technology that uses readily available, renewable energy (a drop in water level of at least 1-2 meters in a flowing stream) and has only two moving parts that can be manufactured and maintained by local personnel.

In the context of the International Drinking Water and Sanitation Decade, hydrum technology has not received the attention it deserves as a potentially useful component in national rural water supply programs. Widely used in the 19th and the early 20th centuries, hydrums have been installed throughout the world for water supply to villages and farms and for small scale irrigation. In India, they supplied water to the famous fountains in front of the Taj Mahal. In recent years the lack of emphasis placed on hydrum technology by international agencies is due to the preference of groundwater over surface water as a source of domestic water supplies. However, in many regions of the world potable ground water is not readily available.

Until recently, research on operating characteristics and standardized designs for hydrums have been lacking. Recently, research has been conducted by the University of Ottawa, the University of Dar es Salaam and elsewhere on commercially-available hydrums as well as simple locally-made models. These tests have determined the characteristics of some commercially-made hydrums with the objective of designing simple locally-made pumps with comparable operating characteristics.

This research needs to be continued in order to improve the design and durability of locally-made hydrums. Locally-made pumps need to be field-tested to determine their performance characteristics and durability under operating conditions in village settings. The social acceptance of these pumping devices will need to be established to determine if and how these devices fit into the existing social patterns of supplying water. These pumps will have to be maintained by the local community which will involve close cooperation, and community participation of local users. Socio-cultural studies will need to be conducted in this connection. Having developed a locally-made, economical, durable and socially acceptable pump, the final step will be to assist in the planning of an indigenous production capacity.

IDRC recently sponsored a workshop held in Arusha, Tanzania to address the above issues and to look carefully at various aspects of the implementation of these systems at the village level within the context of East Africa. The workshop also included a visit to Jandu Plumbers (Arusha) who are manufacturers of hydrams and field trips to observe pumps installed in the vicinity of Arusha. The workshop provided an opportunity for participants to share information on hydram technology and plan for future development of this technology. Research priorities for Africa were discussed and research protocols prepared.

#### Acknowledgements

Mr. D. Tulapona of CAMARTEC and Mr. A. Redekopp of IDRC, served as administrative organizers for this workshop. The following assisted in the research proposal writing process at the end of the workshop. A. Redekopp and J. Chauvin, IDRC, E.J. Schiller, University of Ottawa, E. Protzen, University of Dar es Salaam, and P. Kahangire of the Water Department of Uganda. Finally, E.J. Schiller served as technical editor in the publication of the proceedings.



WORKSHOP CONCLUSIONS AND RECOMMENDATIONS FOR ACTION

Conclusions

1. Conventional pumping methods are becoming more and more difficult to maintain in developing countries. The need to use renewable energy technologies in rural areas has increased. The use of the hydraulic ram pump (hydrām) is an example.
2. One of the problems with hydrām technology is that a majority of potential users are not aware of these pumping devices. Therefore, promotion and dissemination of information of hydrām technology should be increased. Hydrāms are commercially available and technical drawings of working devices already exist. These must be made available to users. Even more detailed technical information must be generated and disseminated.
3. Training of users, water engineers and technicians in installation, operation and maintenance should be stressed.
4. It seems that at present a predominant problem is that most durable hydrāms are prohibitively expensive. There is a need to develop low cost, locally manufactured lightweight versions.
5. The first step in such a development is a good evaluation of existing analytical models as a design aid. All interested groups should be involved in this process.
6. Each country should identify all potential hydrām sites including hydrological, topographical, geographical, water-quality and population data.
7. Each country should make a thorough survey of existing operating and non-operating hydrāms for technical and sociological information.
8. A designed lightweight version should be installed in selected sites and field-tested. To facilitate this, complete operating characteristics must be developed with the aid of a computerized analytical model. Field tests could indicate the need for future design and manufacturing improvements.

9. There is a need to interest manufacturers in the lightweight, low-cost version and improve fiscal benefits by more cooperation between users, design engineers and manufacturers.
10. Though the hydram is a low maintenance device, it is still important to plan for adequate maintenance and spare parts supplies. When schemes are commissioned beneficiaries should feel responsible to protect, operate and maintain the system.
11. Lack of health education makes the community less aware of the importance of improved water supply systems. Also cultural beliefs in some instances may not favour the use of hydrams.

#### Recommendations for Action

1. Countries planning to promote hydram technology should begin with a thorough survey and inventory of potential sites and existing installations. This should include a study of the technical, social and economic potential of hydrams.
2. A common East African computerized hydram model should be completed immediately to:
  - a) generate operating characteristics of all existing hydrams; and
  - b) to assist in the design of new low-cost versions of the hydram.
3. Local manufacture of low-cost, sufficiently durable hydrams should be undertaken.
4. The new versions of the hydram should be installed and field-tested.
5. Health education programmes should be implemented to improve water use habits.
6. Hydram operator-caretakers should be chosen from among the villages and properly trained.

Research Needs

Given the above recommendations, there is a need to conduct research on the technical, social and economic potential of hydrams. Demonstration schemes should also be set up to assess their technical performance and social acceptability, and to train and monitor the effectiveness of village level operator caretakers.



Some delegates at the Workshop on Hydrum Technology

OPENING ADDRESS

**E.M. Ngaiza**

I take this opportunity to welcome participants of this Workshop to Tanzania and Arusha in particular. It is my hope that you had a pleasant trip here. Welcome to Tanzania and please feel at home during your stay.

I would like, at this juncture, to thank IDRC for convening this Workshop in Tanzania and especially in Arusha where CAMARTEC is located. I feel we are very much honoured to have CAMARTEC as co-organizers of the Workshop. We will do our best to make the Workshop a success. Also, we will do our best to make your stay as comfortable as possible.

The theme of the Workshop is of great importance. You all know the current socio-economic problems facing many communities of the developing countries. This has prompted many researchers, social and natural scientists, to explore various alternative means of solving our development problems. Among the socio-economic problems, which is of great importance to our development, is water supply. The question of water supply and sanitation is crucial. We need water for domestic use, for irrigation, and for producing power. This Workshop focuses on the use of water energy to supply water, that is, the hydraulic ram technology.

The use of hydraulic rams to pump water for domestic use and irrigation is not as widespread as the use of other water lifting devices. Many factors are involved but I will make reference to a few. You will have time during the sessions to discuss them in detail. Technical and social barriers affect the widespread use of hydraulic rams. Technically, in each country there have been engineering design problems. In Tanzania, for example, the manufacturers of hydraulic rams are Jandu Plumbers Ltd. of Arusha who have been working on hydraulic rams in East Africa for the last fifty years. The engineering design in use in Tanzania has not changed much and has not been given serious study by experts other than those working with Jandu Plumbers Ltd. It should be possible to modify the design to make it more attractive and less costly.

Socially, the widespread use of the hydraulic rams is affected by the different ways of introducing the technology to the end users. A lack of exposure and knowledge of the technology to the users and potential manufacturers is one of the major factors. The end-users need to be aware of the advantages of using hydraulic rams for domestic and farm water supply. Costs of the pumps should be within the limit of the user's purchasing power.

I hope the participants will have time to consider the problems mentioned above and will finally come out with well considered projects for implementation.

I, therefore, declare this Workshop open and wish you all the best.

## **THE HYDRAULIC RAM PUMP (HYDRAM):**

### **ITS HISTORY, OPERATING CHARACTERISTICS AND POTENTIAL USAGE**

**E.J. Schiller**

#### **ABSTRACT**

The hydram is introduced as one of a series of renewable energy technologies in rural water supply. The operating principles of the hydram are outlined. A short history of hydram development is given. Present day usage is surveyed. The main operating characteristics of hydrams are described. Present and future research activities are noted.

#### **INTRODUCTION**

The hydraulic ram pump (hydram) is one of a group of renewable energy technologies that use the energy of the sun or an energy from that is directly derived from the sun. In the case of the hydram, the energy source is a small drop in elevation in a flowing stream.

The hydram shares several characteristics in common with other renewable energy technologies used in the water supply sector such as windpower pumping, handpumps, stream-driven turbines and solar driven devices. Many of these devices have the capability of being manufactured locally using local skills and materials. These technologies are relatively simple compared to fossil fuel devices that require heat resistant metals, and electrical devices that require an electrical network or an electrical generator. Most renewable energy devices can be operated independently with minimal spare parts needed for regular maintenance. They can therefore function reasonably well even if the transportation and communications network in a country is not highly developed. This factor makes these devices well suited to rural populations that are widely scattered.

#### **THE OPERATION OF THE HYDRAM**

The hydram makes use of the sudden stoppage of flow in a pipe to create a high pressure surge. This is commonly known as water hammer. This high pressure wave is utilized to pump

some of the water to a higher elevation or to a location that is displaced horizontally from the pump. If the flow in an inelastic pipe is stopped instantaneously, the theoretical pressure rise that can be obtained is

$$\Delta H = - \frac{Vc}{g}$$

where  $\Delta H$  = pressure rise (m)

$V$  = the original velocity in the pipe (m/s)

$c$  = the speed of an acoustic wave in the fluid (m/s)

$g$  = acceleration due to gravity ( $9.8 \text{ m/s}^2$ )

The above represents the maximum pressure rise possible. The actual value will be lower since all pipes have some elasticity, and it is impossible to instantaneously stop the flow in a pipe.

To make use of the above principle, a typical hydam is constructed as in the diagram below.

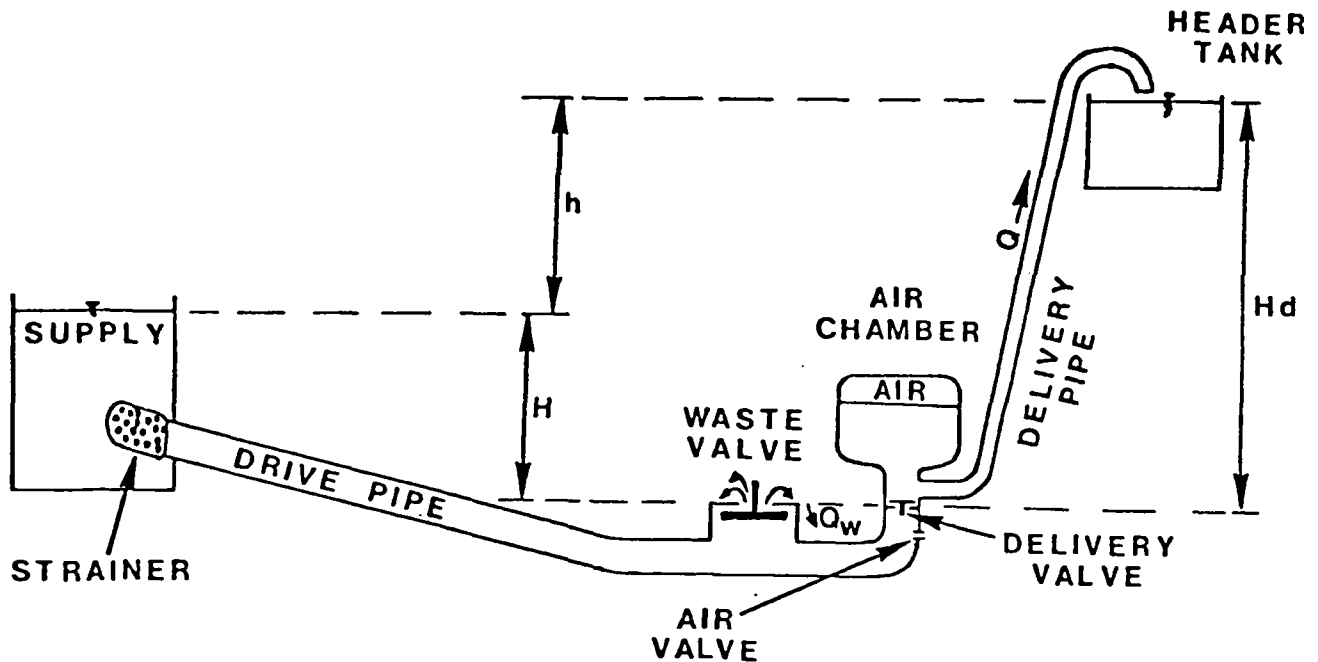

Figure 1: A TYPICAL ARRANGEMENT IN A HYDRAM INSTALLATION

The hydram is simple in construction. It contains only two moving parts, the waste valve and the delivery valve. There are two pipes, the drive pipe leading the water into the pump and the delivery pipe directing the water to the place where it will be stored and subsequently used. An air chamber and air valve are the other two components in the body of the hydram.

The pumping cycle of the hydram begins with the waste valve open. In a natural stream, the supply is taken from upstream, perhaps from a small dam created in the stream. Because of the head created, water accelerates in the drive pipe and leaves through the waste valve. The equation for this acceleration is well known in fluid mechanics and can be given as,

$$H - M \frac{V^2}{2g} = \frac{L}{g} \frac{dV}{dt} \quad (1)$$

where  $M \frac{V^2}{2g}$  expresses the total friction losses

$L$  = length of the drive

and  $V$  = velocity of flow in the pipe

$t$  = time

Eventually this flow will accelerate enough to begin to close the waste valve. This occurs when the drag and pressure forces in the water equal the weight of the waste valve. For the purpose of analysis, the force on the valve can be represented as a drag force,  $F_d$ , given by the equation.

$$F_d = C_d A_v \gamma \frac{V^2}{2g} \quad (2)$$

where  $A_v$  = cross sectional area of the waste valve

$\gamma$  = specific weight of water

$C_d$  = drag coefficient of the waste valve

For optimum operation, the closing of the valve should be as fast as possible. On this basis alone a light valve with a short stroke length is best. However, if a valve is too light it will not open soon enough later in the cycle; on the other hand, if the stroke is too short, not enough water can escape out of the waste valve opening, this limiting pipe velocities and thus reducing water hammer pressures. The proper design of the waste valve must therefore be an optimal balance between all the various factors involved.



The sudden closing of the waste valve creates a high pressure surge as explained previously. This surge is great enough to open the delivery valve and release some of the water into the delivery pipe. With the release of this water, the high pressure surge in the drive pipe collapses and slight negative pressure recoil occurs.

Three significant things occur when the pressure wave collapses in the drive pipe. Firstly, the delivery valve closes thus ending the pressure surge that is sent to the delivery pipe. The air chamber cushions the pressure pulse so that a reasonably continuous flow is sent to the delivery pipe. In this cushioning process the air-water interface is continually agitated and moving. This tends to dissolve the air into the water. The air supply is replenished by a second phenomenon that occurs at this time. The slight negative pressure pulse enables air to be sucked into the air valve. Later in the delivery phase, this air passes the delivery valve and goes to the air chamber. This air valve can be a one-way air valve or it can be a very small drilled hole (1mm) which releases water during the pressure surge and sucks in air during the collapse of the pressure wave.

The third event that occurs at the end of the pressure pumping phase is that the waste valve opens, either by the action of its own weight or by means of an activating spring. When this happens, the flow is ready to begin again. The hydram cycle thus repeats itself continually, at a frequency between 40 to 200 beats per minute. The fact that this pump operates 24 hours per day with only minimal maintenance is one of its main advantages.

#### **THE HISTORY OF THE HYDRAM**

The history of the hydram goes back more than 200 years. We are, therefore, not discussing a new technology, but an old technology that is experiencing a renaissance, brought about by the fossil fuel crisis and energy shortages in general. The hydram shares this characteristic with other renewable energy technologies such as windmills, handpumps and various solar devices.

The first person apparently to try to use a water hammer pressure in a pipe for pumping was John Whitehurst, an Englishman in 1775. His hydram was not automatic, but the operation was controlled manually by opening and closing a stop-cock. Although Whitehurst installed a few of these devices, the apparatus was difficult to operate and did not become very popular.

The inventor of the automatic hydram as we know it today was a Frenchman, Joseph Montgolfier, who patented the device in 1797. He introduced the waste valve that opened and closed automatically and gave us the name "hydraulic ram" pump. This creative Frenchman also

invented the hot air balloon, which in the French language is named after him. However, the hydram of Montgolfier suffered from a defect. The air in his air chamber eventually dissolved, causing intense banging in the mechanism which was especially serious with the larger models. It was his son, Pierre Franois Montgolfier, who designed the air or snifter valve to introduce air into the air chamber. This made possible the design and construction of large hydrams and made it possible to pump water to higher delivery heads.

During the nineteenth century there was intense activity in the design and construction of hydrams often on a very large scale. This activity, which originated in Europe, including Britain, spread to North America. Very large hydrams are reported in the U.S.A. from the end of the nineteenth century (Mead, 1901) with a 10-inch (250mm) diameter intake pipe capable of pumping 870 L/min. to a height of 25m in Illinois and an even larger 12-inch (300mm) diameter hydram in Seattle which is reported to have pumped 1700 L/min. to a height of 43m (Carver, 1918; Mead, 1933). These hydrams were enormous in size and the drive pipe walls had to be made very thick to withstand the water hammer pressures.

With the advent of steam power, fossil fuel driven engines and electrification, this period of hydram manufacture began to decline. Although some few companies have continued to manufacture hydrams, it is only in the last two decades that a renewed interest in hydrams has occurred as the world-wide energy shortage has begun to change our energy patterns. Companies are now developing smaller, lighter hydrams suitable for use in scattered areas.

A list of present day manufacturers and distributors in North America and England is as follows:

- Berry Hill Limited (Davey hydrams)  
75 Burwell Road  
St. Thomas, Ontario N5P 3R5  
CANADA
  
- Rife Hydraulic Engine Manufacturing Company (Rife hydrams)  
132 Main Street  
Andover, New Jersey 07821  
USA

- C.W. Pipe Inc. (Fleming hydro-ram)  
P.O. Box 698  
Amherst, Virginia 24521  
USA
  
- John Blake Limited (Blake hydrams)  
Hydraulic Engineers  
P.O. Box 43  
Royal Works, Lancashire  
ENGLAND BB5 5LP
  
- Green and Carter Ltd. (Vulcan hydram)  
Vulcan Works  
Winchester  
ENGLAND

#### **PRESENT DAY USAGE OF HYDRAMS**

The hydram is employed in many scattered areas of the world, although not in great numbers. They are still employed throughout Europe, England North America although their period of peak usage there dates back to the last century. The famous fountains of India's Taj Mahal were powered by hydrams and they are used in rural areas in Russia.

However, the main area of interest for present-day hydram application is in the countries of the developing world. They are used throughout East Africa. They are most appropriate with streams in hilly terrains, and it is in such regions where hydrams tend to be concentrated.

It is the role of women to carry water in most developing countries, and carrying water in hilly country is especially arduous. Therefore, women have the most to gain by the development of pumping technology (Madeley, 1981).

#### **HYDRAM OPERATING CHARACTERISTICS**

It is standard engineering practice to depict the performance of water pumps by giving their operating characteristics. For the hydram there are two sets of characteristic curves that are especially useful.

The first is a plot of head ratio ( $h/H$ ) versus flow ratio ( $Q/Q_w$ ). For definitions of the symbols see Figure 1. This is a dimensionless curve that illustrates hydram performance for a given supply head. For high head ratios the curves tend to be similar but some divergence is noted for the lower head ratios. Kahangire (1984) found this trend to be true for most of the hydrams that he tested.

In general, these curves show that hydrams can pump much water for low lifts, but as the lift increases the amount of water decreases.

Another useful curve is the curve of efficiency, defined as

$$e = \frac{Q \cdot h}{Q_w \cdot H}$$

as a function of delivery flow. This tells how efficiently the hydram pumps the water. This is important where the driving source of water is limited and waste water must be kept to a minimum. Where the stream flow is abundant, the efficiency is not so important. However, efficiency readings give us a good indication of the hydraulic performance of the hydram. High efficiency machines have low friction losses and are hydraulically well designed. For a given head ( $H$ ), the efficiency curves of different hydrams will indicate which type of hydram is most suitable for the particular setting. Figure 3 shows the efficiency curves for various hydrams operating with a head of 2m.

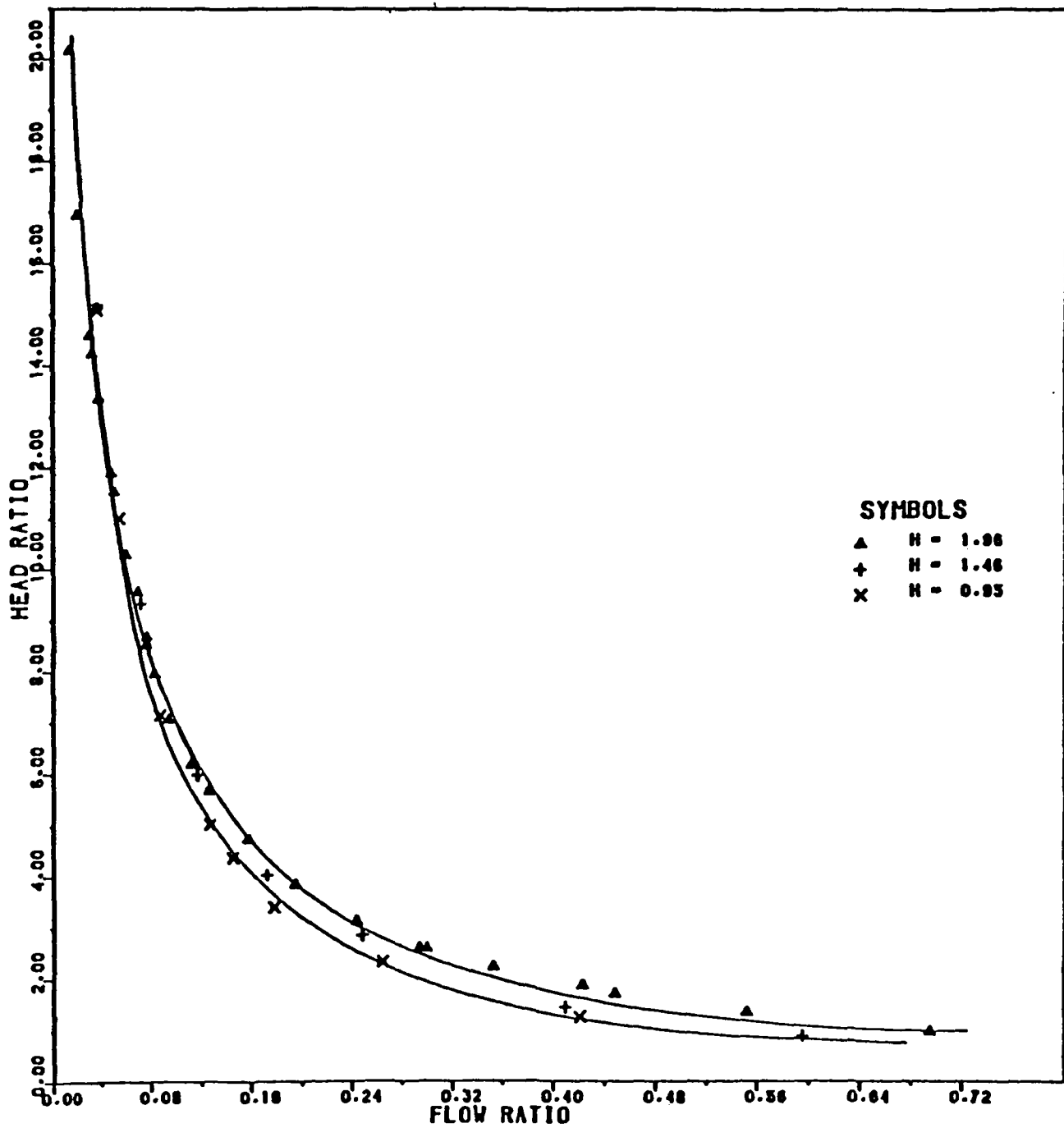

Figure 2: DAVY HYDRAM HEAD RATIO VS FLOW RATIO

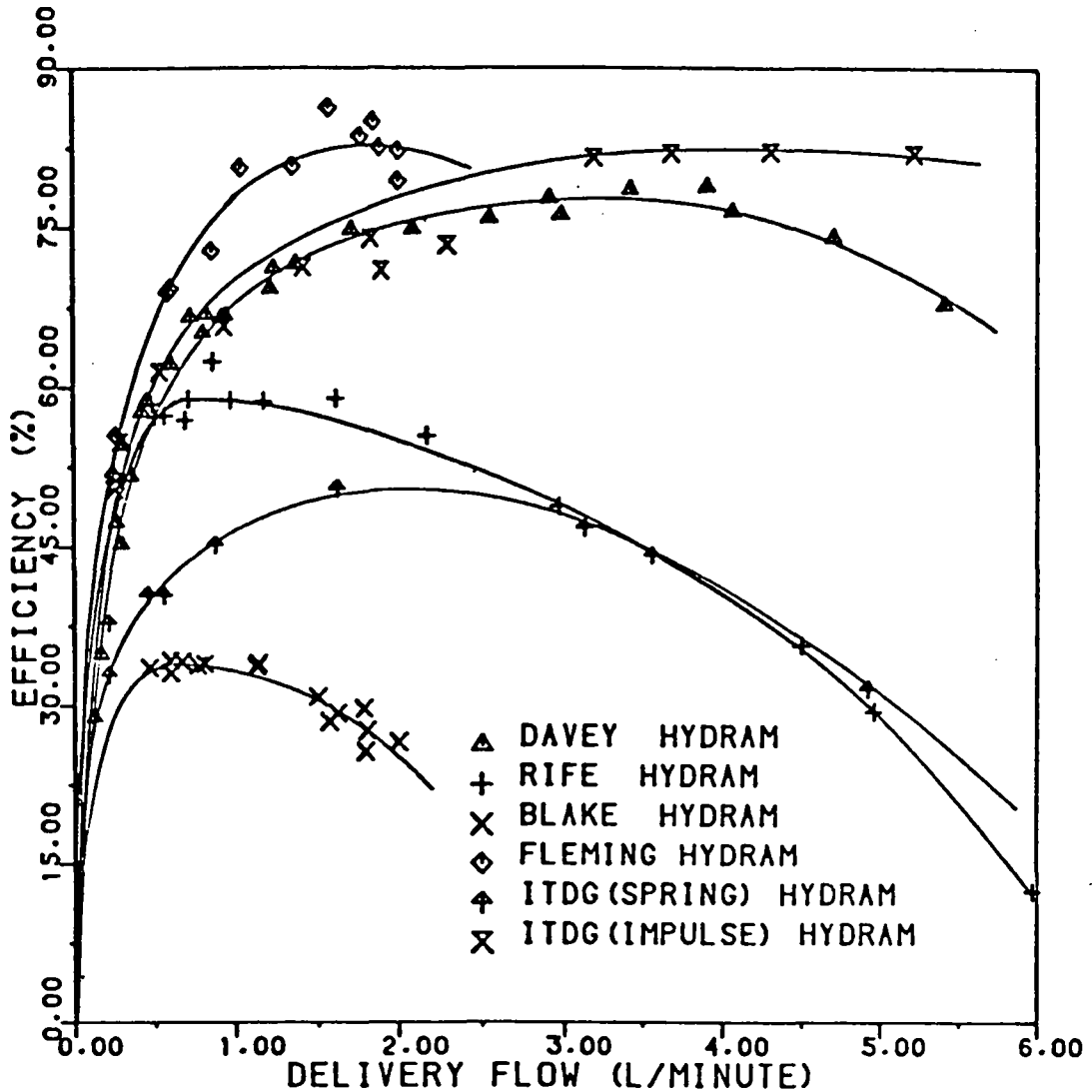

Figure 3: EFFICIENCY VS DELIVERY FLOW

#### COMPUTER MODELLING OF THE HYDRAM

The purpose of computer modelling is to allow designers to predict the influence of given factors on hydram performance. Kahangire (1984) has developed a computer model for hydrams which has been produced in basic computer language for micro-computers. Data describing the proposed site together with hydram dimensions and friction loss characteristics are inputted into the programs. Operating characteristic curves are then produced by the computer program. Figures 4 and 5 are curves plotted by the computer model. They indicate the kinds of analysis that can be done with the use of this computer model. Figure 4 can be useful in assisting the design of more efficient waste valves and Figure 5 can be used to help install hydrams in different sites with different heads available.

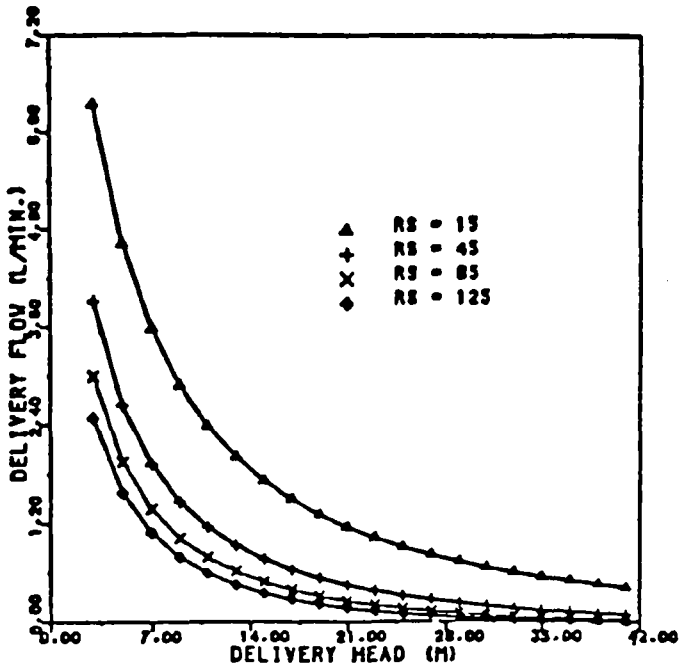

Figure 4: EFFECT OF FRICTION HEAD LOSS OF THE WASTE VALVE ON PUMP CAPACITY

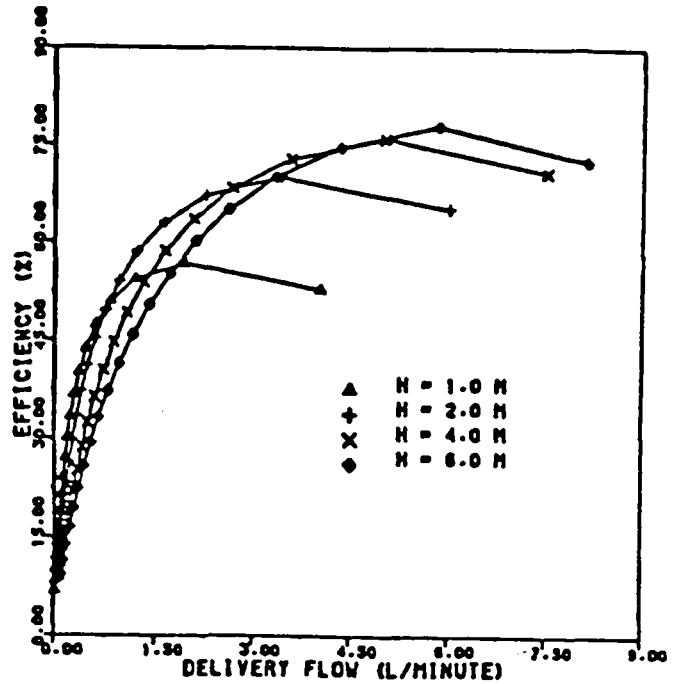

Figure 5: EFFECT OF SUPPLY HEAD ON HYDRAM EFFICIENCY

**AREAS OF HYDRAM INVESTIGATION AND DEVELOPMENT**

Because of increased interest in this renewable energy technology, there are a number of centres where research has been done or is still continuing in hydram pumps.

Research activity has been reported in Indonesia (Hanafie and de Longh, 1979) and the Technische Hogfeschool Eindhoven and the Delft Hydraulic Laboratories, both in Holland. The Intermediate Technology Development Group (ITDG) in England has published books in this area (Watt, 1978). In the USA, Volunteers in Technical Assistance has published hydram manuals (Kindel 1975; Inversen, 1979) and the Peace Corps has published a "Training Manual in Conducting a Workshop in the Design, Construction, Operation Maintenance and Repair of Hydrams" 1981.

The University of Ottawa has completed extensive tests on hydrams in order to (1) determine the operating characteristics of commercial hydrams, (2) compare these operating characteristics with those of a locally-made hydram, and (3) suggest design modifications for locally-made hydrams.

Finally, in Tanzania, the Institute for Productivity Innovation at the University of Dar es Salaam is conducting tests to model hydram performance with a goal to improve present designs.

#### **FUTURE HYDRAM DEVELOPMENT**

Three main areas for future research are identified:

- 1) Existing hydram designs, some of which are very durable have a price that makes it difficult to be purchased in developing countries. Economic studies should be done to determine true hydram costs, spread over the lifetime of the hydram.
- 2) Low priced hydram models need to be designed, manufactured and field-tested.
- 3) An improved computerized hydram model needs to be developed and produced for computation with microcomputers. This would enable rapid comparisons to be made of existing hydrams. It would also be a useful tool in future design modifications.



#### REFERENCES

1. Behrends, F.G. (1926) "Use of the Hydraulic Ram". The Farm Water Supply (Part ii). Cornell Extension Bulletin 145, New York State College of Agriculture, Cornell University.
2. Cabine, Charles (1937) "Joseph de Montgolfier et le Belier Hydraulique". Proceedings, Institution of Civil Engineers, London.
3. Carver, T.H. (1918) "Hydraulic Ram Shows 91% Efficiency". Engineering News Record, Vol. 80, No. 21, New York.
4. Dickenson, H.W. (1937) "Early Years of the Hydraulic Ram". Proceedings of the Institution of Civil Engineers, January, pp. 73-83, London.
5. Hanafie, J. and DeLongh, H. (1979) "Teknologi Pompa Hidraulik Ram". Institut Teknologi Bandung.
6. Inversin, A.R. (1979) "Hydraulic Ram for Tropical Climates". Vita Publication, Vita, Mt. Rainier, Maryland.
7. Iversen, H.W. (1975) "An Analysis of the Hydraulic Ram". Journal of Fluids Engineering, ASME No. 75-FE-F, Transactions. New York, ASME, June, pp. 191-196.
8. Kahangire, P.O. (1984) "An Experimental Investigation and Design of Hydraulic Ram Pumps", M.A.Sc. Thesis, Civil Engineering Department, University of Ottawa.
9. Kindel, E.W. (1975). A Hydraulic Ram for Village Use. A Vita Publication, Mt. Rainier, Maryland.
10. Krol, J. (1952) "The Automatic Hydraulic Ram". Proceedings of the Institution of Mechanical Engineers, Vol. 165, pp. 53-65.
11. Lansford, W.M. and Dugan, W.G. (1941) "An Analytical and Experimental Study of the Hydraulic Ram". Bulletin No. 326, Vol. 38. University of Illinois Engineering Experimental Station.
12. Madeley, J. (1981) "Ram Pumps and Kenyan Women's Water Trek", World Water, London, October, pp. 51-52.

13. Mead, D.W. (1933) "The Hydraulic Ram". Hydraulic Machinery. New York: pp. 358-383.
14. Mead, D.W. (1901) "A Large Hydraulic Ram". The Engineering Record, Vol. 44, No. 8, New York: August.
15. Peace Corps (1981). A Training Manual in Conducting a Workshop in the Design, Construction, Operation, Maintenance and Repair of Hydrams.
16. Protzen, E.P. (1980) "A Proposal for Simple Performance Prediction of the Hydraulic Ram". (Unpublished Reserch results), Institute for Production Innovation. University of Dar es Salaam, Dar es Salaam.
17. Schiller, E.J. (1982) "Development of a Locally Made Hydraulic Ram Pump". ENERGEX '82 Conference Proceedings, Solar Energy Society of Canada. August, pp. 503-506.
18. Schiller, E.J. (1982) "Renewable Energy Pumping from Rivers and Stream". Water Supply and Sanitation for Developing Countries. Michigan: Ann Arbor Science Publishers, pp. 53-64.
19. Silver, Mitchell (1977), Use of Hydraulic Rams in Nepal. A guide to Manufacturing and Installation, Kathumandu, Nepal: UNICEF, September.
20. Smallman, W.S. (1934) "The Hydraulic Ram, Its Construction and Use". Newcastle, Australia, Newcastle Division of the Engineers of Australia, paper No. 569, pp. 357-360.
21. Stevens-Guille, P.E. (1970) "An Innovation in Water Ram Pumps for Domestic and Irrigation Use". London, Appropriate Technology, Vol. 5, No. 1.
22. Stevens-Guille, P.D. (1977) "How to Make and Install a Low-cost Water Ram Pump for Domestic and Irrigation Use". Cape Town: Department of Mechanical Engineering, University of Cape Town, August.
23. Watt, S.B. (1978) A Manual on the Hydraulic Ram for Pumping Water. London, Intermediate Technology Limited.

THE APPLICATION OF HYDRAM PUMPS IN RURAL  
WATER SUPPLY SCHEMES IN TANZANIA

A. Mzee

**ABSTRACT**

A survey of Tanzania's water development goals is given, together with the mix of technologies presently used in the water supply sector. A preliminary survey of hydram potential is advocated, together with a field testing program. The proposed program should determine in detail the potential for hydram development in Tanzania.

**INTRODUCTION**

The Tanzanian twenty-year (1971-1991) long-term water supply goals, in accordance with UN Water Supply and Sanitation Decade resolutions, plans to supply everyone with clean, potable and adequate water within easy reach by 1991.

A major constraint in the implementation of the Rural Water Supply Programme is a lack of adequate financial resources for construction of new projects as well as operation and maintenance of the completed schemes. With the high cost of fuels and equipment, it is of utmost importance to deploy technologies with less energy demand that can utilize available renewable energy resources. It is equally important to fabricate and maintain locally-made appropriate devices used in harnessing such resources. At present, most of water pumps in rural areas are run on diesel. These pumps and engines need a constant supply of fuel, skilled manpower, spares, equipment and transportation for their maintenance. These are scarce and costly commodities. To reduce dependency on these items, the need for alternative methods is desirable.

A water sector review in 1976 showed that water supply systems were being undertaken in accordance with the following technology mix:

TECHNOLOGY USED AND UNIT COSTS OF EXISTING SYSTEMS (1976)

TYPE OF SUPPLY	% TOTAL POPULATION SERVED	PER CAPITA COST (Shs)	
		DESIGN POPULATION	PRESENT POPULATION
Surface gravity	28	230	345
Surface diesel powered pump	41	250	375
Surface hydram pump	*	*	*
Surface windmil pumped	*	*	*
Borehole diesel power pumped	22	300	450
Borehole windmill pumped	*	*	*
Shallow wells hand pumped	9	80	120

\* Negligible population

Cost analysis showed that it was necessary to adapt least cost, simple technology options if the programme goals were to be achieved. Further, the Government declared its intention to go for options such as wood/bamboo, windmills, hydraulic rams, etc. Reporting to the party (CCM) conference in 1980 the Ministry of Water and Energy stated, "It is the Government's intention to encourage the use of hydraulic rams whenever it is difficult to convey water by gravity. Batteries of rams can be installed instead of diesel engines". The report was adopted by the party. Hitherto, no serious consideration has been given to the field of hydrams in the program. The hydram potential has not been determined, although it is believed there is significant potential in Kilimanjaro, Tanga, Iringa, Mbeya, Rukwa, Ruvuma, Morogoro, Kigoma, Kagera and other hilly regions where perennial rivers are abundant. Further, the knowledge available with regard to the development and operation of the schemes is too scarce to enable provision of national guidelines. In order to popularize the option for wide-scale application, preliminary knowledge on limitations, cost implication, acceptability, adaptability, reliability and maintainability is necessary. This would assist in making sound decisions on the application of hydrams. To avoid an ad hoc approach, the following research needs are considered necessary.

**PRELIMINARY SURVEY**

The main objective of the survey is to collect and compile relevant hydrological and topographical data in order to determine water flows and topographic levels. This would form the basis of selecting suitable sites for hydram schemes. Water Master Plan Studies already carried out in many regions would be the main source of information.

A survey of village patterns including locations, size, population and water demand will be carried out to assess areas of use and relevant size of hydrant project. This will help in knowing the extent to which the hydrant technology will be used in comparison with other technology mixes. An idea of the most common size of a hydrant pump likely obtained from such information would further assist in fixing standards for the hydrant designs.

Upon selection of suitable project locations further preliminary surveys will be undertaken to investigate the economic factors, existing social conditions, attitude of villagers towards scheme ownership, participation in construction and maintenance of the hydrant water supply system.

#### **ORGANIZATION OF THE HYDRANT FIELD TESTING**

Based on the findings of the preliminary survey, hydrant schemes will be constructed at selected villages under normal project implementation procedures. Guided by the input from the villagers, the method of implementation shall be decided with emphasis of beneficiaries' participation, self-help labour or otherwise. The installation of hydrants shall be done by project personnel who would continue to inspect and monitor its performance.

During the course of the hydrant operation, performance tests shall be carried out. This will include collection of important information and taking measurements to verify design parameters and to assess durability of hydrants under field conditions. The behaviour of various components of the system such as valves, springs, air chambers and pipe fittings shall be monitored. An analysis of hydrant parts at the end of the project shall be necessary. Parameters such as volumetric efficiency, water head, water output, frequency of use, stream flows shall be recorded. Suitable and reasonably accurate devices shall be used in taking measurements.

Careful consideration shall be given to the location of the schemes. For ease and convenience of construction and maintenance, inspection and monitoring the accessibility to the site will be important. The scheme construction shall be as simple as possible. Locally available materials such as burnt mud bricks or wood staves shall be used to construct the head pond and supply reservoirs. The piping material shall be determined by the drive, delivery and supply heads available for each scheme. For the purpose of comparing operating characteristics, it is proposed to install both locally and commercially made hydraulic ram pumps.

## CONCLUSION

In view of the high cost of fuels and lubricants, difficulties in transportation, shortage of skilled manpower and materials to maintain diesel engines, it is imperative to encourage use of indigenous renewable energy resources such as hydraulic ram pumps. The research proposed here aims at understanding the suitability of such applications in Tanzania. At the end of the research, answers to the following questions should be found:

1. Are hydraulic ram pump applications technically, economically and socially acceptable?
2. What is the approximate cost and size of a village hydram scheme?
3. What would be the most common size of a hydram to be used in the water programme?
4. What is the unit cost of water production using hydrams as an optional technology?
5. To what extent can hydrams be used in the water programme?
6. What is the extent of energy saving using this option?
7. What are the weak parts of the hydraulic ram as a pumping device?
8. What level of reliability can be expected from a village hydram scheme?
9. How comparable in performance and economy are locally fabricated hydrams?
10. To what extent should beneficiaries' participation be expected in construction, operation and maintenance of a hydraulic ram system?
11. Who should be encouraged to own a hydraulic ram scheme - a public institution or a private undertaking?

Finally, it is hoped that the existence of such preliminary knowledge will assist planners, engineers and financiers in making sound decisions on the use of hydraulic ram pumping schemes in the development of water schemes in the country.

THE USE OF HYDRAMS FOR WATER PUMPING IN TANZANIA

by D. Tulaona

**ABSTRACT**

The need for more renewable energy technologies in the rural water supply sector is highlighted. Some design aspects are discussed and the outlook for local manufacture is surveyed.

**INTRODUCTION**

In Tanzania, as in most developing countries, the problem of water supply is not only its general scarcity, but also where it is plentiful there is the problem of getting it to where it is needed. In principle, there is water everywhere in Tanzania even in the drier central plateau. The success of the Shallow Wells Project in the Lake Zone and Morogoro Region proves the point. The southern and northern highlands are endowed with fast flowing rivers which have enough water all the year round. The great lakes which almost surround half of the country and smaller lakes scattered throughout the country are all cold water sources.

In general, Tanzania's water sources can be utilized for domestic and irrigation purposes. The saline water of the sea has been left out of this discussion purposely as its use for domestic or irrigation purposes requires technologies not included in this Workshop. The three forms in which cold water occurs are: running water (rivers, springs, streams), stagnant water (lakes, dams, ponds) and underground water. Being on the surface, the first two forms are easy to tap and ready for use, provided health precautions are observed. Underground water, on the other hand, has to be extracted by digging and drilling wells to bring water to the surface. The water table varies from place to place thus making the task of lifting the water even more difficult.

There are a number of water-lifting devices with varying outputs and uses. There are the pumps which range from the simple low-output handpumps to the high-speed high-capacity centrifugal pumps. Others include Persian wheels, Archimedean screws, axial flow pumps and hydraulic rams. Of course, there are also shadoofs, windlass and pail, treadmill and others less familiar in this country.

All these devices require energy to operate them. The energy required varies according to the type of device and the amount of water to be lifted. The low-speed, low-output devices such as handpumps, Persian wheels, shadoofs, windlass and pail, treadmill and Archimedean screw all utilize human or animal power. Windmills are also used to drive pumps which lift water from bore holes and deep wells. The well-known handpump and the windlass and pail are primarily for lifting water for domestic use and stock watering only. Due to their low output, they are not suitable for lifting water for irrigation. In most cases, they are used to lift water from wells. The Persian wheel lifts water from wells, the shadoof which lifts water from wells or rivers (canals) and the treadmill, which lifts water from rivers, are mostly found in Asia but could be introduced in this country as well.

The high-speed and high-output centrifugal pumps which supply water to urban areas or large scale irrigation farms are beyond the scope of this paper. But the medium capacity centrifugal or piston pumps driven by fuel engines and used to supply water to rural communities need special mention. A number of these were installed in many villages in this country but unfortunately most of them are not working. There are many factors which have contributed to this problem. Lack of expertise in the villages to repair the engines and pumps, shortage of spare parts and the shortage and ever-rising prices of fuels are just a few of the factors.

Hydraulic rams, which are not very numerous in this country, require neither fossil fuel, animal nor human power to pump water from running streams to very high levels. Although the technology for this device has been in existence for the last two centuries, its use in Tanzania has not been widespread. A few hydrams were installed and used in settler coffee and sisal estates around Arusha and Moshi about forty to fifty years ago, but most of them are not working now due to neglect. In recent years, however, people have come to realize the usefulness of hydrams, especially after engine operated pumps failed due to reasons mentioned above. During this period there have been efforts to continue production and supply of hydrams in Tanzania. Jandu Plumbers Ltd. of Arusha has been the only local manufacturer of hydrams.

#### **HYDRAM PERFORMANCE**

The performance of a hydram is determined by the working fall down which the driving water travels and also by the vertical height to which the pumped water must be raised. Thus, when working fall and vertical height are known, the output can easily be determined from operating charts or tables. The increase of vertical fall usually increases the amount of drive water and thus increases the output of the hydram.



To calculate output of the hydram, some required information must be known. The vertical fall in meters, volume of drive water in litres per minute and the vertical delivery elevation in meters must be measured accurately. A typical efficiency of hydrams is around 60%. The output can, therefore, be estimated according to the following simple formula:

$$D = \frac{V \times F \times 6}{E \times 10}$$

where D = Output in litres per minute

V = Volume of water flowing through drive pipe in litres per minute

F = Vertical (working) in meters

E = Vertical elevation of delivery in meters

After obtaining the D in litres per minute, hourly and daily outputs can be obtained by multiplying it by 60 and 1,440 respectively.

The table below shows the performance of a hydram at different working falls and delivery heights.

Working Fall (Meters)	Vertical height which water is raised above hydram (meters)											
	5	7.5	10	15	20	30	40	50	60	80	100	1
1.0	144	77	65	33	29	19.5	12.5					
1.5		135	96.5	70	54	36	19	15				
2.0		220	156	105	79	53	33	25	19.5	12.5		
2.5		280	200	100	125	66	40.5	32.5	24	15.5	12	
3.0			260	180	130	87	67	51	40	27	17.5	12
3.5				215	150	100	75	60	46	31.5	20	14
4.0				255	173	115	86	69	53	36	23	16
5.0				310	236	185	118	94	71.5	50	36	23
6.0					282	216	140	112	93.5	64.5	47.5	34.5
7.0							163	130	109	82	60	48
8.0							187	149	125	94	69	55
9.0							212	168	140	105	84	62
10.0	LITRES PUMPED 24 HOURS						245	187	156	117	93	69
12.0	PER LITRE/MIN OF DRIVE WATER						295	225	187	140	113	83
14.0							265	218	167	132	97	
16.0								250	187	150	110	
18.0								280	210	169	124	
20.0									237	188	140	

Source: John Blake Limited

## SOME DESIGN CONSIDERATIONS

Over the years many researchers have been experimenting with new materials and new methods of manufacture in an attempt to design a lightweight hydraulic ram. Most of these lightweight designs have proven unsatisfactory due to the material not being strong enough to support the high pressures which develop within the hydram. Although the hydrams have initially performed well, it is not known for how long they will continue to function. It is doubtful whether they will be capable of running for fifty years or more, like the traditional ones made of heavy cast steel.

Volunteers in Technical Assistance (VITA) and the Intermediate Technology Development Group (IITDG), to mention just two organizations, have done research on simple hydrams which have been field-tested with encouraging results. The VITA hydram is constructed from available galvanized iron pipe fittings and locally-made valves. The construction requires no special skill and minimum number of tools. A drill press and some hand tools are all that is required. Welding, brazing and soldering are not required. The cost of the hydram is very low compared to the cast one but its durability is yet to be determined.

The first consideration for hydram design is durability. The hydram exploits the non-compressibility of water. If water flowing at a certain speed is abruptly stopped, a high pressure (water hammer) will develop. The hydram utilizes this property by harnessing the water hammer and any pump body with a tendency to expand under pressure or is made of weak material must not be used as it will break. Although rather expensive, it is necessary to use heavy non-elastic materials. Heavy cast steel with parts of copper and brass have proved most ideal.

Another very important consideration is the internal contour of the hydram body, both from the point of view of frictional losses which will prevent the maximum speed from being achieved and air pockets which will prevent attainment of maximum pressure. Loss of speed and pressure will seriously affect the efficiency of the pump.

The success of the hydram will be guaranteed if rigid materials are used, if it is correctly made and installed and requires very little attention. The working parts which need changing about once a year are the rubber valve discs. Only simple maintenance is required to ensure that the waterways are clear and free-flowing.

## MANUFACTURE OF HYDRAMS

The manufacture of hydrams in Tanzania is not as widespread as would have been expected, taking into consideration the acute problem of water lifting. There exists adequate manufacturing facilities but the main constraint on widespread local manufacture of the pumps is that strict quality control during manufacture is essential if the ram is to operate efficiently for a long period of time. Well made pumps have been known to run continuously for more than fifty years with only minimum maintenance but poorly engineered pumps break down easily and quickly.

During the era of cheap oil of the 1950's and 1960's, interest in the use and, therefore, the manufacture of the hydrams waned in Tanzania and elsewhere. However, due to the fact that hydrams require no fuel to run them, they are now back in favour. Because of this lapse in interest for the hydrams, many people do not know much about them, but now that they have been rediscovered, they should be popularized and made available.

In Europe and America, a few firms are still manufacturing hydrams, though not as a main product line. John Blake Ltd. of England and Rife Hydraulic Engine Manufacturing Co. of New Jersey, U.S.A. are well known and experienced hydram manufacturers. Unfortunately, hydrams from these long-standing manufacturers are not being imported into Tanzania. The few imported hydrams were installed before the cheap oil era. One of the main reasons for the underutilization of hydrams is a lack of awareness of this technology among potential users.

The sole manufacturer of hydrams in Tanzania is Jandu Plumbers Ltd. of Arusha. A variety of sizes are produced but the production rate is very small. Only about ten hydrams are produced per month but the demand for them is increasing, both within the country and in neighbouring countries. Jandu Plumbers could produce more if the hydrams were made the main product line. As mentioned earlier, there are a number of manufacturing firms in Tanzania with adequate facilities to produce hydrams. These firms could be persuaded to include hydrams as a product line and would be willing to do so if the market could be guaranteed. Small scale industries which are mushrooming all over the country could be utilized to manufacture the hydrams, especially at the assembly stage. Complicated parts could be manufactured by medium or large scale industries which have better production facilities. Small scale industries could produce the simple parts and perform simpler operations and the final assembly.

THE HYDRAULIC RAM PUMP IN KENYA

Oyuko O. Mbeche

**ABSTRACT**

The present rural water supply structure in Kenya is outlined, and reference made to the role of hydrams. Community involvement, organizational financing, operation and maintenance and public health aspects of rural hydram development are surveyed.

**INFORMATION**

Reports from the Ministry of Water Development (MWD) state that the access of the rural population to improved water supplies varies widely from 13-15% as a national average to 3-4% in some districts. The Government, through the Ministry, has initiated four national Rural Water Supply Programmes over the years involving some 280 schemes, half of which are operational, with the other under design or construction.

It is estimated that one-half to two-thirds of the rural population with access to an improved water supply is directly supplied through the MWD schemes. The rural water supplies under the MWD are administered mainly through the following programmes:

- Rural Water Supply Programmes (RWSI, RWSII, RWSIII and RWSIV) started in early 1970
- Self-help Schemes Programmes
- Rehabilitation Programme

International agencies and bilateral donors, for example, the Government of Sweden through SIDA and the World Bank, have over the years assisted the RWS in the country.

Hydraulic ram pumps along with other types of pumps have been used in many Self-help Schemes Programme following the 1976 International Women's Year - Harambee ya Wanawake Kwa Afya. In the early 1950's and prior to 1980, British-made hydrams dominated the Kenyan market. Today in 1984, due to stringent controls on foreign exchange, the major firms who had been importing these and similar foreign-made hydrams, no longer stock them. The inexpensive Intermediate Technology

Development Group (ITDG), U.K., and Volunteers in Technical Assistance (VITA), USA, hydrants produced at rural and village polytechnics in the country are now more popular among rural communities.

#### **COMMUNITY INVOLVEMENT AND ORGANIZATIONAL FINANCING**

The Kenya Government, through its Ministry of Water Development has been able to implement various water schemes in the country. The Ministry, however, has indicated that the problem experienced in water supply is the difficulty in obtaining payment for the water supplied coupled with the lack of community involvement. A water use study carried out by the Ministry has revealed that only about 30-50% of water distributed and invoiced in the rural areas in Kenya are paid for by the users. The reason is that due to culture and tradition, water is free and the idea of paying for water is altogether strange, if not repugnant. This defeats many self-help efforts, such as the Rural Development Fund (RDF), by killing any forthcoming cash contributions and possible labour input. Similarly, the use of communal water points have suffered setbacks due to questions of revenue collection, responsibility and ownership.

#### **OPERATION AND MAINTENANCE**

Different types of ownership generate different management structures, due to the fact that different problems arise depending upon whether the structures are privately, institutionally or publically owned. The most difficult problems arise from types of ownership resulting in unfairness in distribution, such as the exclusion, restriction and interference in institutional activities. Other problems result from the general failure of water users, particularly in communal government projects, to share responsibility for hygiene and cleanliness at the source. For example, sometimes communities fail to contribute the labour required to prevent the pumping site from lapsing into a state of disrepair. Finally, for many government or donor projects in the rural communities a common problem is one of a lack of follow-up with a reliable maintenance system. The ideal situation would occur if people at the communal or village level would be able to buy, own, manage, maintain, repair, and overhaul or replace the pump, if and when the need arises. For every pump installation there is also a need for local organization within the communities with an elected and highly motivated management committee to insure a reliable program of future care and maintenance.

## **PUBLIC HEALTH**

It is a truism that a community cannot exist without water. However, access to that water has direct and implicit costs to the community. These costs vary with each community in terms of time and energy spent in collecting water, ill-health due to lack of sufficient water, ill-health due to contaminated water, and in some cases, actual cash paid for water.

At the outset, it is important to determine a community's health situation which should include:

1. the determination of the incidence of water-related diseases, such as skin diseases, trachoma, diarrhoeas, cholera, bilharzia, and others;
2. the community's level of knowledge and awareness;
3. the community's practices and expectations; and
4. the community's social and economic structure.

After determining the communities' health status, a sustained programme of water and health education should be developed to create an awareness and appreciation of clean, safe water in rural areas through community involvement and participation.

HYDRAULIC RAM PUMP TECHNOLOGY AND PRACTICE IN ZAMBIA

W.T. Weerakoon and V. Liyanage

**ABSTRACT**

A hydram installation in the Western Province of Zambia is examined in detail. Its history of usage, modifications and improvements are documented. Test results and analysis for this hydram installation are given.

The rural water supply situation in Zambia is surveyed with emphasis on community participation programs. Research on locally-made hydrams at the University of Zambia is described and preliminary conclusions are drawn.

**INTRODUCTION**

Historical information reveals that hydraulic ram pumps have not been used in Zambia except in a few instances. This may be due to the fact that the full potential of this particular technology has not been exploited. However, it appears that windmills have been most popular among farmers to lift water from boreholes. With the introduction of engine and electrically-driven pumps, windmills too, got phased out of the system. The only known hydram is installed at St. Mary's Mission in Kawambwa (Luapula Province). This pump was installed in 1961 and has a supply head of 9 metres and delivery head of 70 metres. The diameter of the drive pipe is 6 inches (150mm) and the capacity is 182m<sup>3</sup>/day. The main storage tank is situated at a distance of 3.5km away. After nearly fifteen years of use, this pump has had to be repaired several times. Main repairs were carried out on the delivery pipe and bronze impulse valve seat. Since 1976, this pump has not been operating properly. It was repaired once again by the Technology Development and Advisory Unit (TDAU) and it is now in operation with an output of 144m<sup>3</sup>/day.

Due to the increased price in fuel and difficulty in obtaining foreign exchange, it has become necessary to look at the possibility of reintroducing hydraulic ram pumps in Zambia. At present, Zambia has to rely on engine- or electrically-driven pumps. The maintenance of these pumps are now becoming expensive and difficult. The hydram because of its low cost, ease of operation, dependability, efficiency and simplicity in construction offers a better choice to Zambia than other pumps. However, these pumps will be restricted to specific areas where a sufficient and steady water supply is available with a minimum required water head.



Since hydrams have not been widely used, it is not possible to provide comprehensive information about their operation. However, it can be concluded that due to foreign exchange difficulties and a lack of infrastructural facilities available, repairs and maintenance of conventional pumping systems has become an extremely difficult task. It is in this context that hydrams can play an important role, both in the community water supply and agricultural development.

#### THE HYDRAULIC WATER RAM PUMP IN THE WESTERN PROVINCE

The hydram at the Bubenshi River was installed by the manufacturer in 1961, when St. Mary's Mission was established in this region. The water is taken from the river at a spot of 9m above the hydram. It is led through a pipe to an open surge tank, 36m from the ram. From there, the water goes through the drive pipe to the ram (see Figure 1). The breather pipe was not present. The ram pumped the water through a 3.5km long 2-inch (50mm) delivery pipe to the main storage tanks, 70m above the ram. According to the manufacturer's data, the ram capacity was 100m<sup>3</sup>/day.

From the start, the ram installation experienced a technical fault: the drive pipe burst. A team from the manufacturing company (Blake) visited the site and suggested strengthening of the drive pipe, especially at the elbow bend.

The community, using water from this installation, was expanding and after some time the ram was considered to be too small. It was replaced by a diesel pump and later by two electric pumps, all situated in a pumphouse near the inlet of the supply pipe of the surge tank. The electric pumps have a combined capacity of 290m<sup>3</sup>/day.

However, the maintenance of the diesel pump became increasingly troublesome, and the power supply to the electric pumps was irregular, especially during the rainy season. An automatic on/off switching mechanism for the electric pumps failed to operate. This led to an erratic water supply, sometimes interrupting the water supply to the users. To overcome these problems, it was decided to use the hydram installation again.

During the initial use of the hydram, the bronze impulse valve seat had shattered. A new cast-iron valve seat was copied from the remainder of the old one and installed in 1975. Meanwhile, the delivery pipe of the ram was increased to 3-inches (75mm) and led from the hydram to the pumphouse, where it was connected to the pump's delivery pipe. According to Blake's data, the ram can pump up to 182m<sup>3</sup>/day under these circumstances. These flows have not been obtained at this site. When the TDAU engineers visited the site, the hydram was pumping, but only occasionally did this flow reach the tanks.

## MODIFICATIONS CARRIED OUT ON THE HYDRAM

The interference of shock waves in the drive pipe caused an effective hydraulic blockage in the pipe. It may have been contributing to the bursting of the drive pipe as well. To overcome this interference, a breather pipe was welded on the drive pipe about 4m downstream of the elbow (see Figure 1).

The rubber of the faulty non-return valve was cut to the appropriate size. The holes in the impulse valve seat were cleaned. The diameter of the hole in the impulse valve rubber was increased over a depth of 5mm to allow a greater valve opening. Provisions were made to have the rubber move easily over the valve seat (see Figure 2).

Finally, the valve rubber was secured by a tapered rubber washer in the lowest position. The diameter enlargement in the rubber had to extend over 10mm in length in this configuration (see Figure 3). Several other modifications have been tried out with different results. None of these were finally incorporated and are therefore not included in this paragraph.

## RESULTS OF THE MODIFICATIONS

After the installation of the breather, it was found initially that the ram was still beating irregularly and weakly. The interference of shock waves in the drive pipe could no longer be observed. After cleaning the holes in the impulse valve seat and the introduction of the cut-out in the valve rubber, the ram beat became strong and steady. Systematic tests of this modification - indicated as floating valve rubber - were carried out. The complete test results are presented in Tables 1 and figures 4 and 5. It was found that the hydram was pumping up to  $48\text{m}^3/\text{day}$  with a high beating frequency.

An attempt to increase the hydram performance by increasing the stroke of the non-return valve failed completely. The hydram was only pumping air and the output in the tanks was nil. Blocking one of the four air vents did not alter this. Next, the impulse valve rubber was secured in the lowest position by a tapered rubber washer. With this modification systematic tests were carried out as well. The complete test results are presented in Table 2 and figures 4 and 5.

TABLE 1

Hydrum performance, measured at main storage tanks, floating valve rubber

Valve setting (revolutions)	Pumped volume (m <sup>3</sup> /day)	Ram speed (beats/min)
1	10	114
2	39	110
3	41	108
4	45	108
5	48	106
6	48	106

TABLE 2

Hydrum performance, measure at main storage tanks, fixed valve rubber

Valve setting (revolutions)	Pumped volume (m <sup>3</sup> /day)	Ram speed (beats/min)
2	51	108
3	91	80
4	108	66
5	115	60
6	123	58
7	119	56
8	132	56
8 + 1 pump	290	--
8 + level control	123	56

The hydram performance increased dramatically while the beating frequency reduced. The maximum pumping capacity was found to be  $132\text{m}^3/\text{day}$ . To reduce the chance of pumping air, the water level in the surge tank of the ram was controlled by letting small amounts of air escape through a tap. This reduced the ram performance by 8%.

Using a flat rubber washer instead of a tapered one increased the maximum measured ram performance by 8% to  $144\text{m}^3/\text{day}$ . After fifteen hours pumping, however, the outer part of this washer was completely smashed. The surface of the valve seat was also damaged; small parts had disappeared. It was also found that with the fixed valve rubber, the hydram could cooperate with one electric pump. The pumping capacity was then  $290\text{m}^3/\text{day}$  which is just as much as both electric pumps. A third pump further increased the pumped volume of water.

#### DISCUSSION ON THE TEST RESULTS

It can be seen clearly from figures 4 and 5 that the fixed valve rubber modification had the highest pumping capacity and the lowest beating frequency. Reducing the maximum stroke of the impulse valve rubber reduced the pumped volume and increased the beating frequency.

The largest measured volume of water being pumped was 75% of the manufacturer's prediction. Unfortunately, only the diameter of the delivery pipe and the delivery height was stated, and it is not clear whether the friction of the 3.5km delivery pipe length was included as well. Both floating and fixed valve rubbers increased the effective taper of the impulse valve. However, the required axial movement of the floating valve rubber was apparently much slower as compared with the elastic bending of the fixed rubber and reduced the magnitude of the waterhammer shock wave needed for pumping. Since it was observed that the beating frequency with the floating rubber was higher and didn't vary very much with the valve setting, the conclusion may be justified that the valve never opened completely. This would reduce the maximum waterflow through the impulse valve and therefore reduce the waterhammer pressure. The damage of the surface of the valve seat may have three causes:

- Cavitation or surface fatigue
- Corrosion of the valve seat during the six-year inactive period
- Casting faults

If the damage was caused by cavitation or surface fatigue, the damaged area will increase, eventually leading to failure of the valve seat. In this case, one may use a harder material for the valve seat, like cast steel to delay or stop the phenomenon. It may be possible, and even likely that due to the waterflow and the impact of the valve ruber, corroded parts have been cleaned and small bits of material near shrinkage cracks or graphite inclusions have been torn off. In this case, the damaged area will not increase.

## **COMMUNITY PARTICIPATION**

Community involvement and participation in water projects has been one of the built-in features in Zambia. According to the Third National Development Plan (TNDP), it is clearly stated that the Ministry of Health and all those working in the health field will redouble their efforts in educating and mobilizing the people to take greater responsibility in promotion and preservation of health and prevention of diseases. Since the Government alone cannot provide adequate water, refuse disposal and environmental health facilities for all, communities will therefore be encouraged to undertake these projects on a communal basis, with the technical advice available from the Ministry of Health, Water Affairs and other agencies. An example of such a community activity is the Public Stand Water Supply in Mwachisompola Health Demonstration Zone.

Organization of public participation is usually encouraged through existing networks and government agencies. Usually, project managers seconded from their respective duties for a specific period in these projects are the key figures responsible for organizing public participation. Financing comes from either the Government or outside agencies. For example, funds for the above project came from the International Reference Centre for Community Water Supply (IRCCWS) in the Netherlands.

In almost all projects, due to lack of technically qualified manpower, breakdowns occur which are not attended to immediately. Lack of spares and transport and preventive maintenance programmes can be said to be the other features that aggravate this situation. Training of manpower and educating the communities can go a long way to cope with this situation.

## **RURAL WATER SUPPLY SITUATION IN ZAMBIA**

During the Second National Development Plan (1972-1976), about 1,531 wells, 342 well points, 652 boreholes and 100 piped water supplies were completed under the Village Cooperative and Water Supplies Programme. Approximately 250,000 people benefited from these facilities, bringing the

total of rural population with hygienic water to 2.1 million. During the INDP (1979-1983), some progress was made, but due to increased fuel prices and erratic behaviour of the world economy, it was not possible to maintain the same speed of progress.

Still, large numbers of people have no access to clean water supply. Due to an absence of adequate reliable water supply, many children under the age of six years die. Statistical reports indicate that more than 70% of the diseases are connected with unclean water. An attempt has been made by the Government and local authorities to make available safe water to all rural villages. Although cities and urban areas usually have satisfactory water storage and distributing facilities, still much more work is needed to make clean water available to the rural population.

#### RESEARCH AND DEVELOPMENT ACTIVITIES

The first research and development activities related to hydrams started in 1975 by the Magoye Regional Research Station (Department of Agriculture) in Magoye. The second pump was manufactured by Jere (TDAU). Both these pumps had not been previously tested properly, so that it was felt necessary to carry out tests to determine the operational viability of these pumps. Work reported here is a result of the extensive work carried out by Mwafuililwa of School of Engineering. This project was jointly sponsored by the School of Engineering and Technology Development and Advisory Unit (DTAU).

The purpose of the Lusaka project was to determine the performance of the TDAU and Magoye manufactured hydrams in order to examine the effect of varying the supply head, supply rate, drive pipe, impulse valve stroke and tension, the hydam beat frequencies, delivery height and the delivery rate on the efficiency and performance of the hydam.

The following conclusions were reached from the tests carried out on the two pumps:

1. An increase in number of cycles per minute decreases the efficiency. This can be seen for the curves 5 and 6 (see Figure 6).
2. The delivery rate increases with the increase in efficiency up to a certain point only (see Figure 7).

3. An increase in delivery head tends to decrease the overall efficiency of the pump. The maximum delivery head seems to depend more on the supply head than the impulse valve settings (see Figure 8).

Finally, the Lusaka project indicated that these pumps can be easily used for active water pumping, since they perform well under the environment in which they were tested. However, it is important to field-test them before any decision can be made to manufacture them locally. It is also felt that some other designs should be introduced for field-testing to compare the efficiency of each design and select the ones best suited to the local conditions.

## CONCLUSION

The Third National Development Plan clearly indicates the necessity to generate more and fuller employment as a major objective of development, and to that end, to adopt technology which is labour-intensive, paying due regard to the resources available and the social needs of the Zambian economy. Further diversification of the economy from a copper base to agriculture has been emphasized by the Party and its Government in their efforts to reduce the economy's dependence on copper. Besides these objectives, the basic need to supply clean water for drinking is also an important factor in any rural development in Zambia. There is an urgent need to have an active research programme in hydraulic ram technology in Zambia and to undertake research and demonstrate the capability of this inexpensive technology which needs very little skills to maintain. It is also important to train the local artisans to manufacture and maintain these pumps at the village level.

TABLE 3: NOTATION FOR CURVES ON FIGURES 6, 7 AND 8

a) SUPPLY HEAD = 3.205m

<u>Curve Number</u>	<u>Valve Stroke</u> (mm)	<u>Bolt Tension</u> (no. of clock-wise turns)
1	10	0
2	20	0
3	30	0

b) SUPPLY HEAD = 4.22m

<u>Curve Number</u>	<u>Valve Stroke</u>	<u>Bolt Tension</u>
4	10	0
5	10	1
6	10	2
7	20	0
8	30	0

REFERENCES

1. Report on Trouble Shooting Visit to Waterram in Kawambwa, Luapula Province. Colijn, A; Hommerson, G.; Shouten, C.P.; and Vlugman, A.A. 1982.
2. The Hydraulic Analysis of Water Rams. Mwafuililwa. 1983
3. Public Standpost Water Supplies, Volume 13 and 14. IRCCWS Publication. 1979.
4. Third National Development Plan, Zambia. 1979.
5. Public Stand Water Supplies (PSWS) Project Lusaka. 1983.



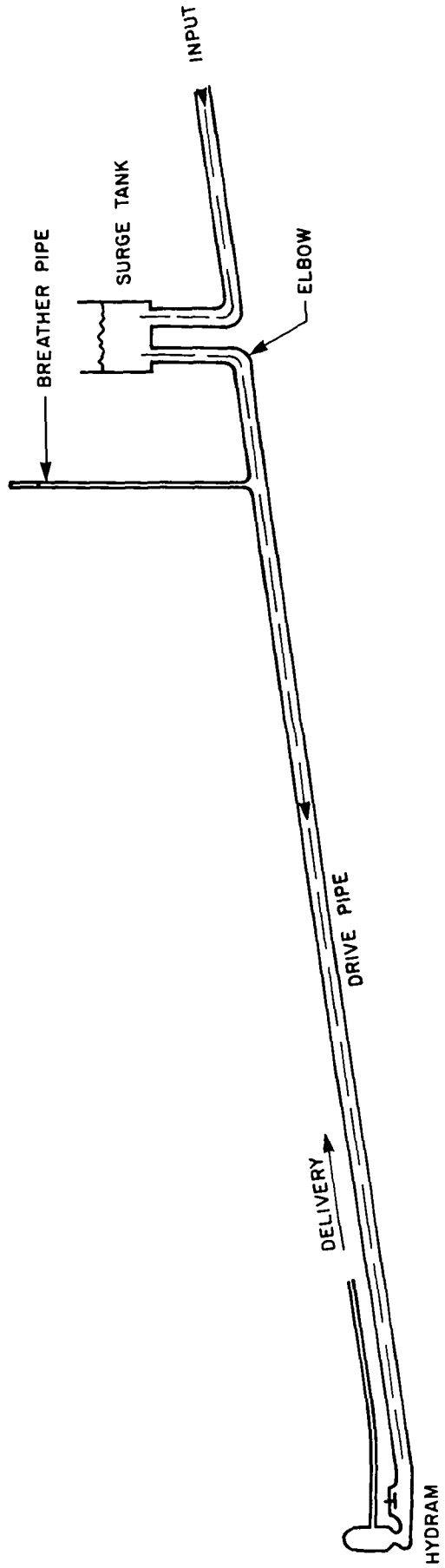

FIG. 1 : LAYOUT OF THE HYDRAM INSTALLATION AT THE BUGENSHI RIVER

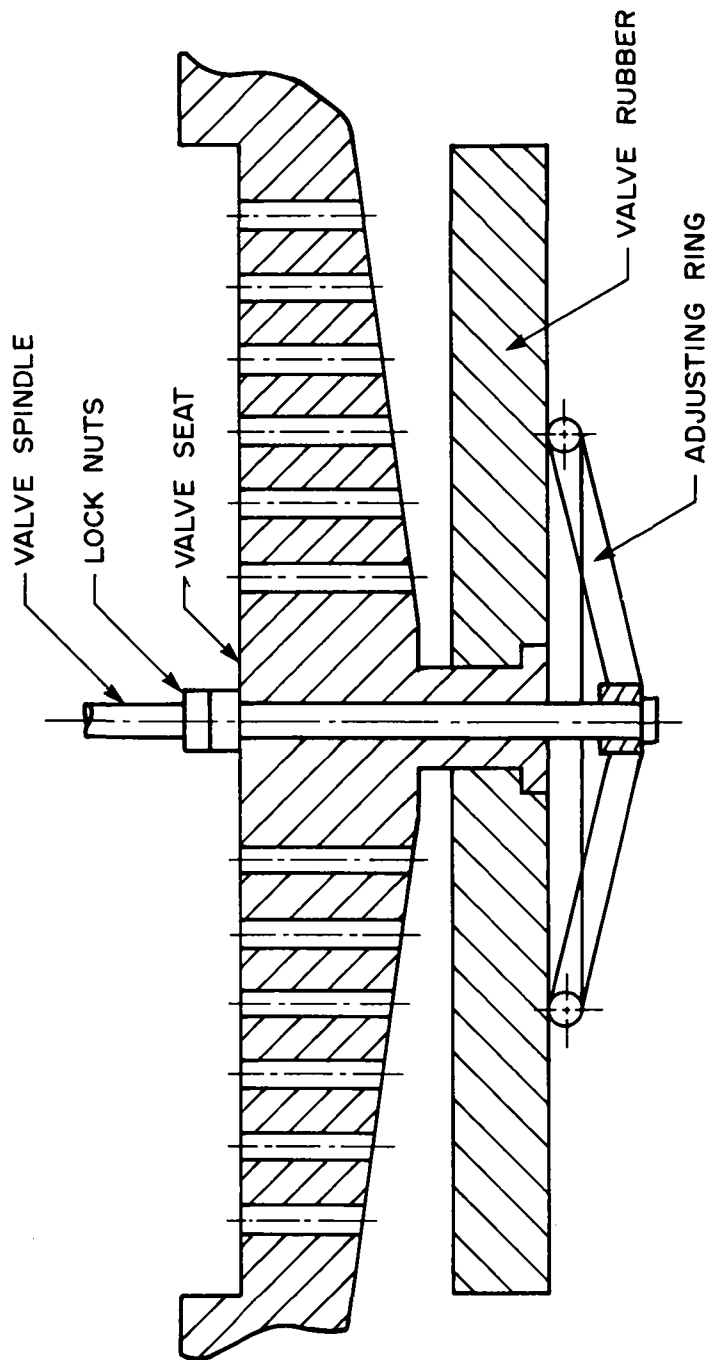

FIG. 2 : IMPULSE VALVE, FLOATING VALVE RUBBER

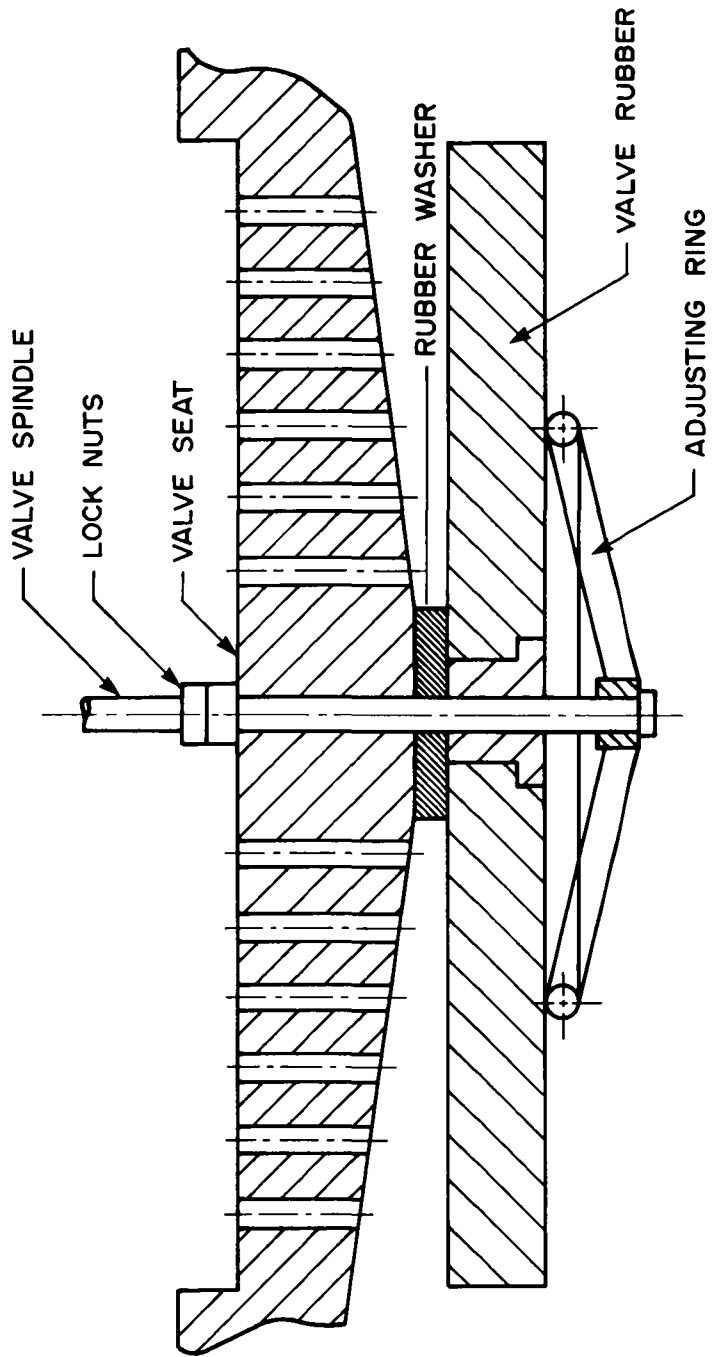

FIG. 3 : IMPULSE VALVE, FIXED VALVE RUBBER

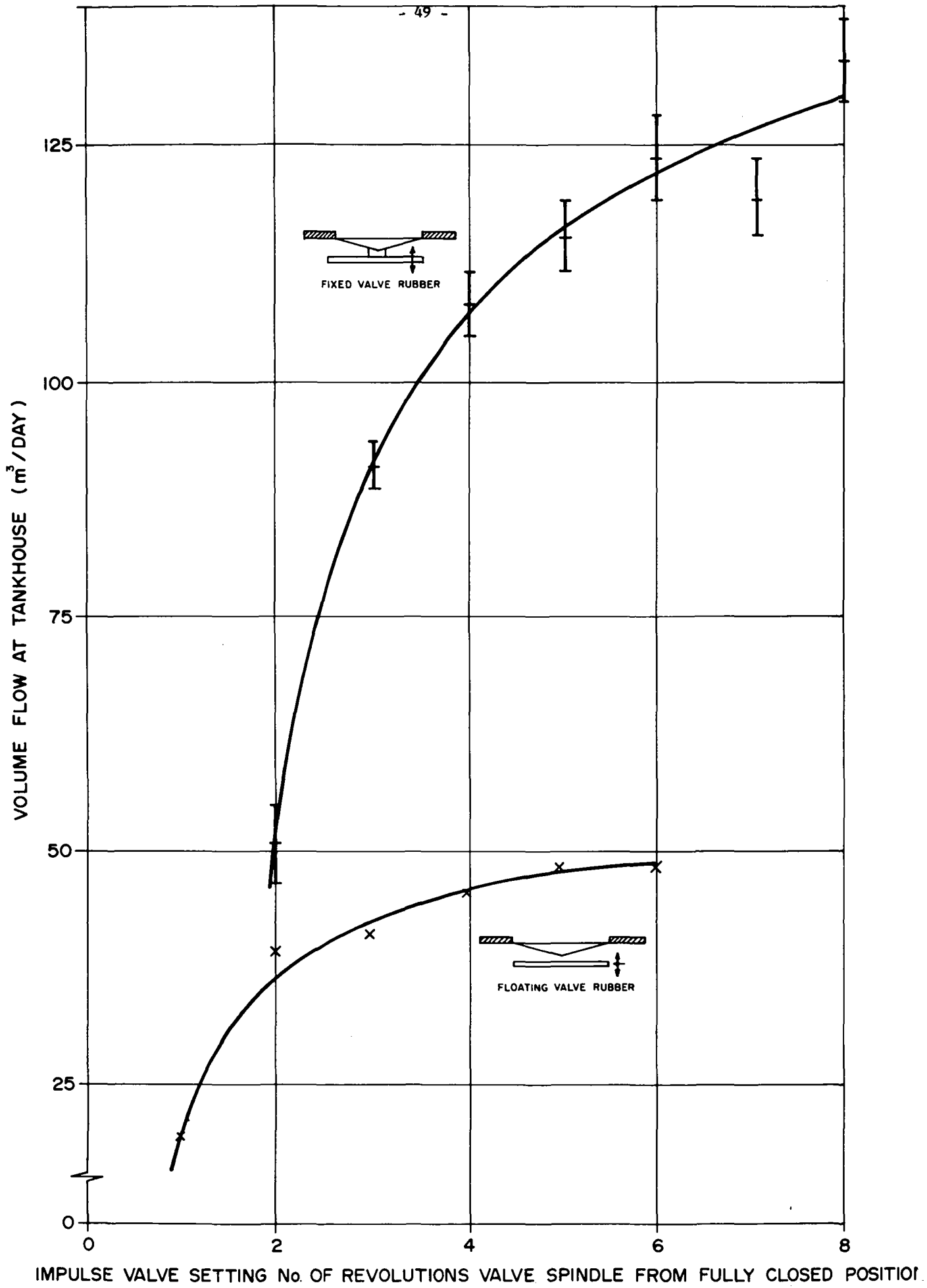

FIG. 4 : HYDRAM PERFORMANCE CURVES

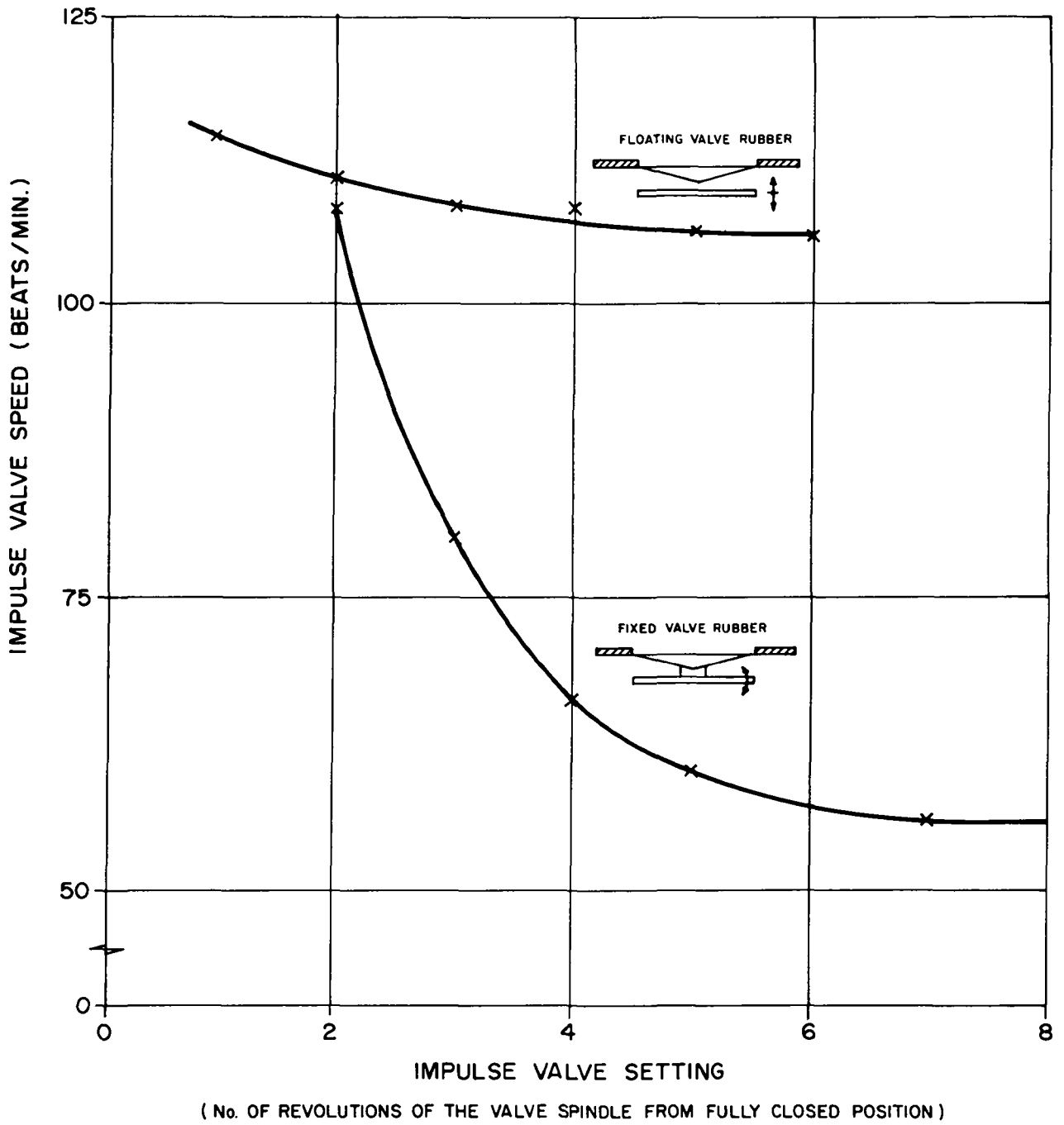

FIG. 5: HYDRAM FREQUENCY AS A FUNCTION OF IMPULSE VALVE SETTING

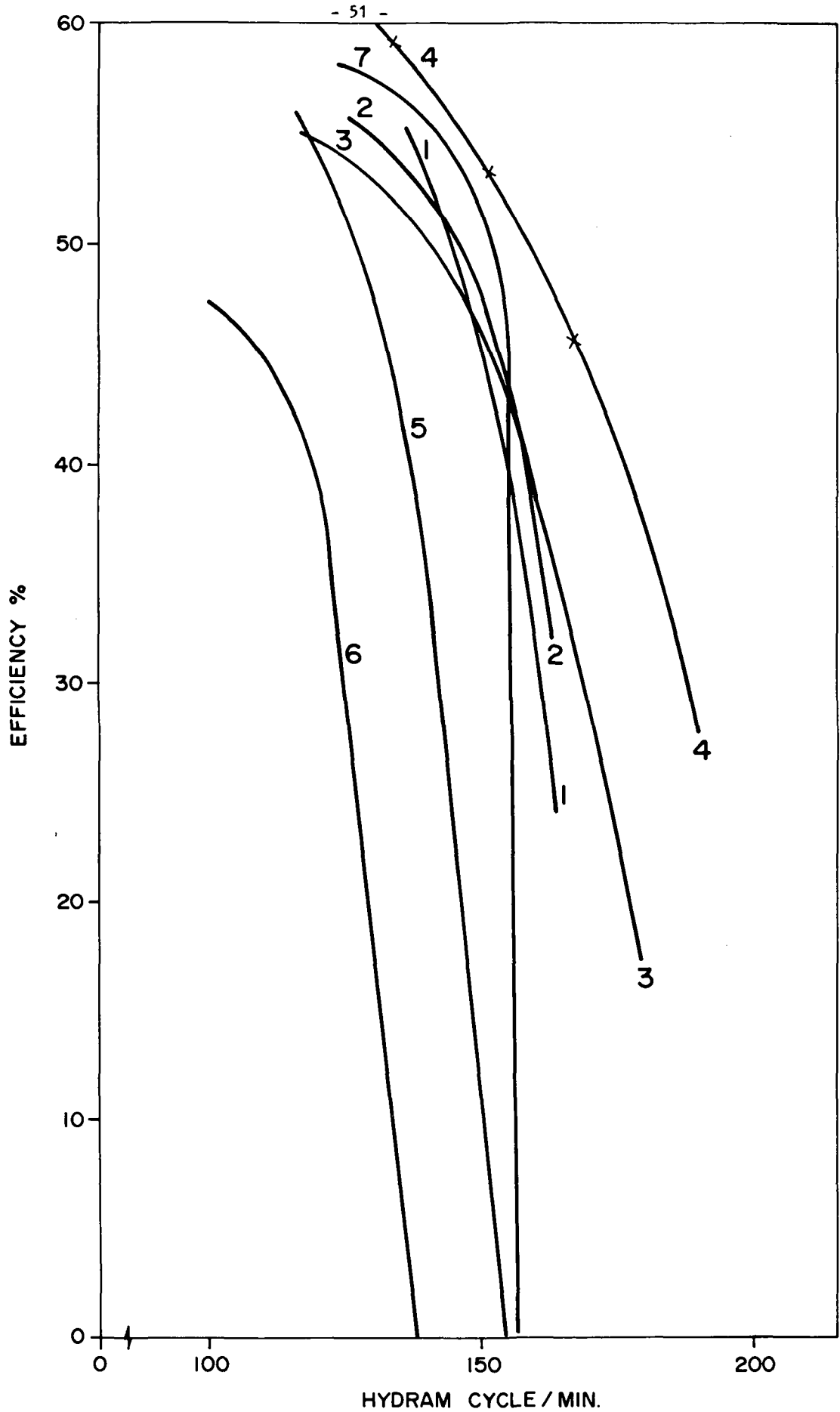

FIG. 6: EFFICIENCY VS. BEAT FREQUENCY

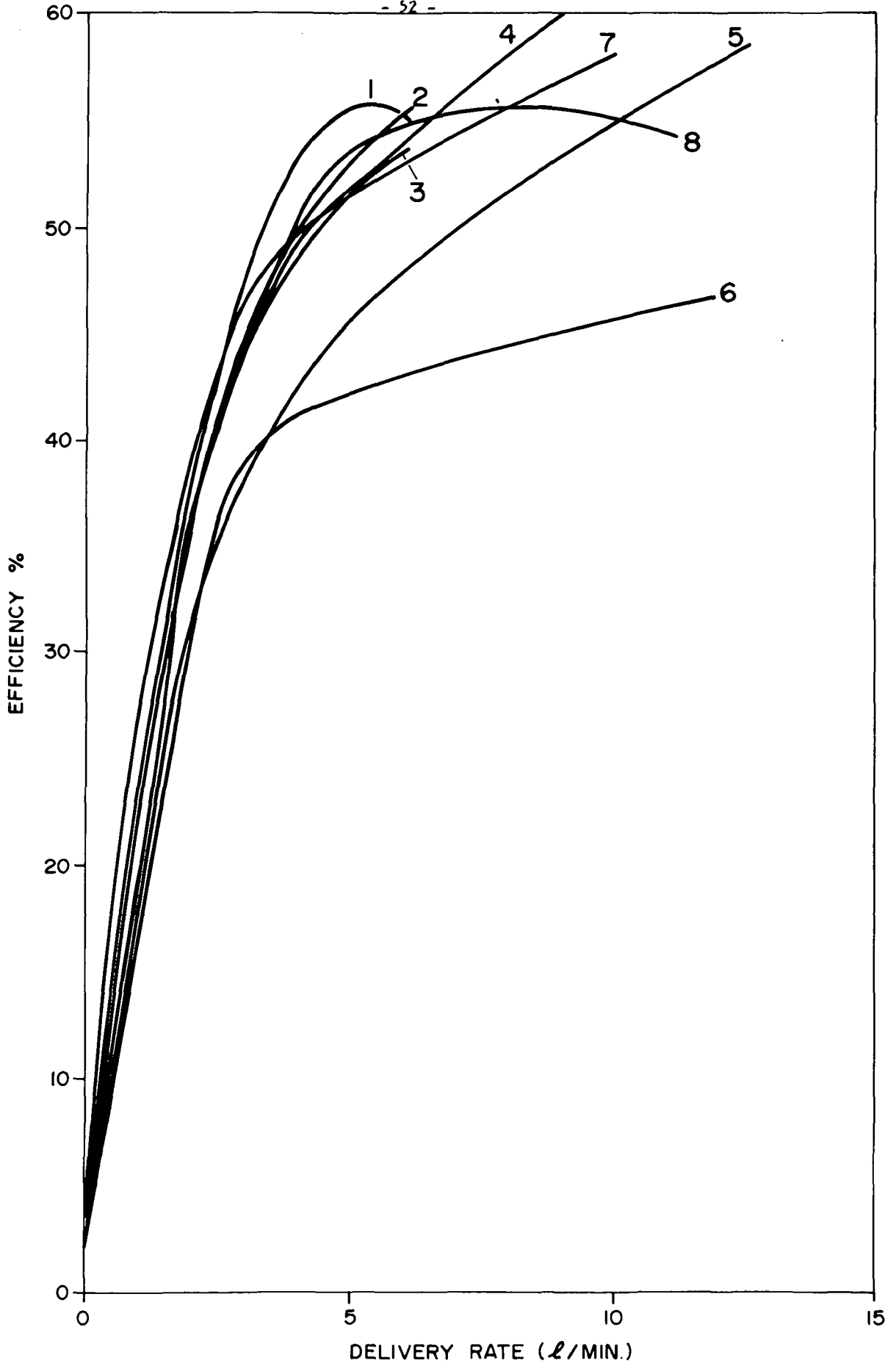

FIG. 7: EFFICIENCY VS. DELIVERY RATE

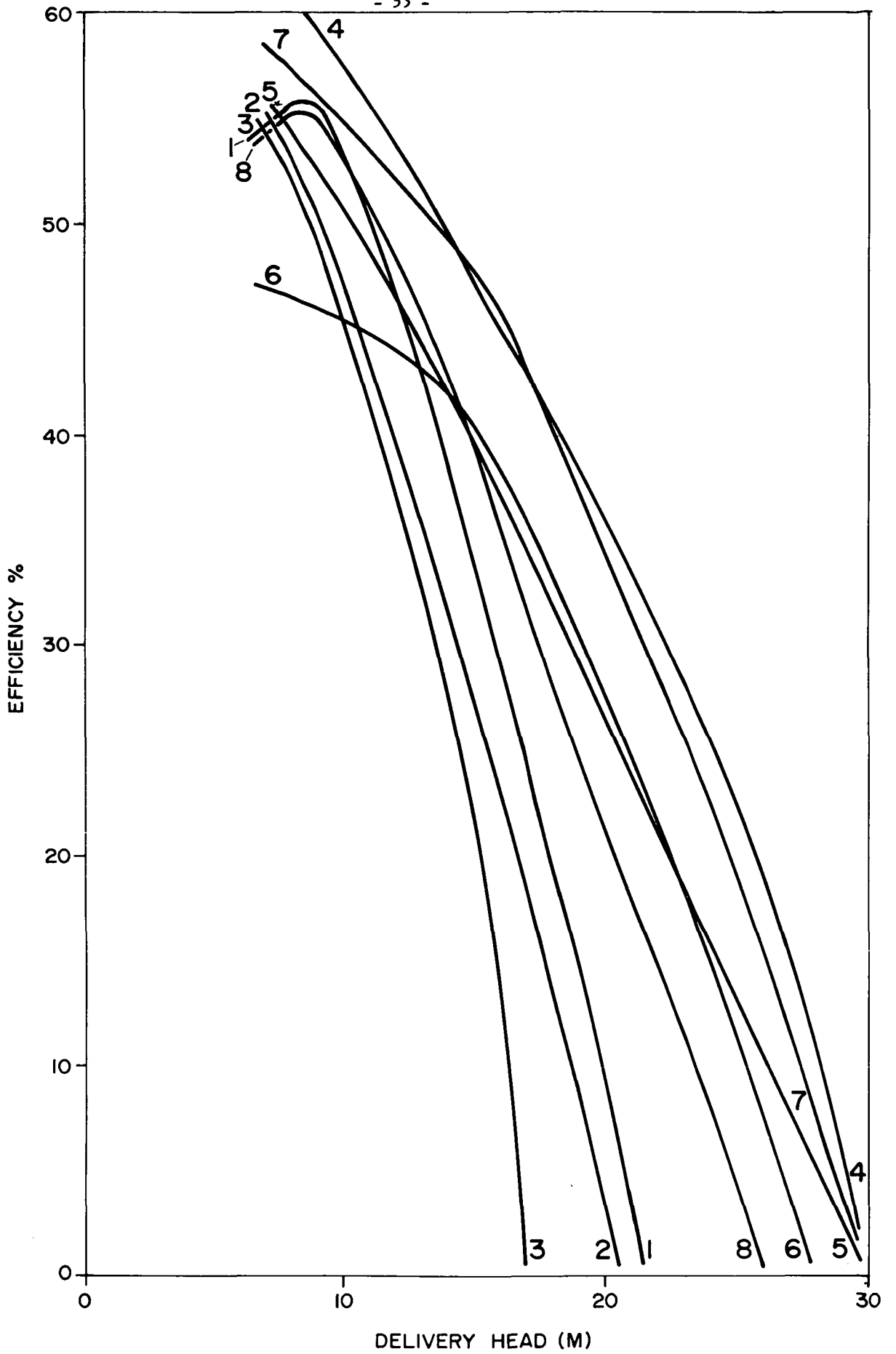

FIG. 8: EFFICIENCY VS. DELIVERY HEAD



## PRACTICAL ASPECTS OF HYDRAM OPERATION

E.J. Schiller

### ABSTRACT

Selection of the correct hydram for a given physical site is considered. The measurement of field parameters and site construction is outlined. Some key operation and maintenance factors are noted.

### INTRODUCTION

In the following paper some practical aspects of hydram installation and operation will be discussed. The first question to be addressed is the selection of the hydram, in terms of type and size for a given site. Having correctly installed the hydram, questions of daily operation and maintenance need to be considered.

### SELECTING A HYDRAM FOR A GIVEN SITE

It was previously shown that two characteristic curves embody most of the operating characteristics for a given hydram. The correct use of these curves can aid in choosing the best hydram for a given site.

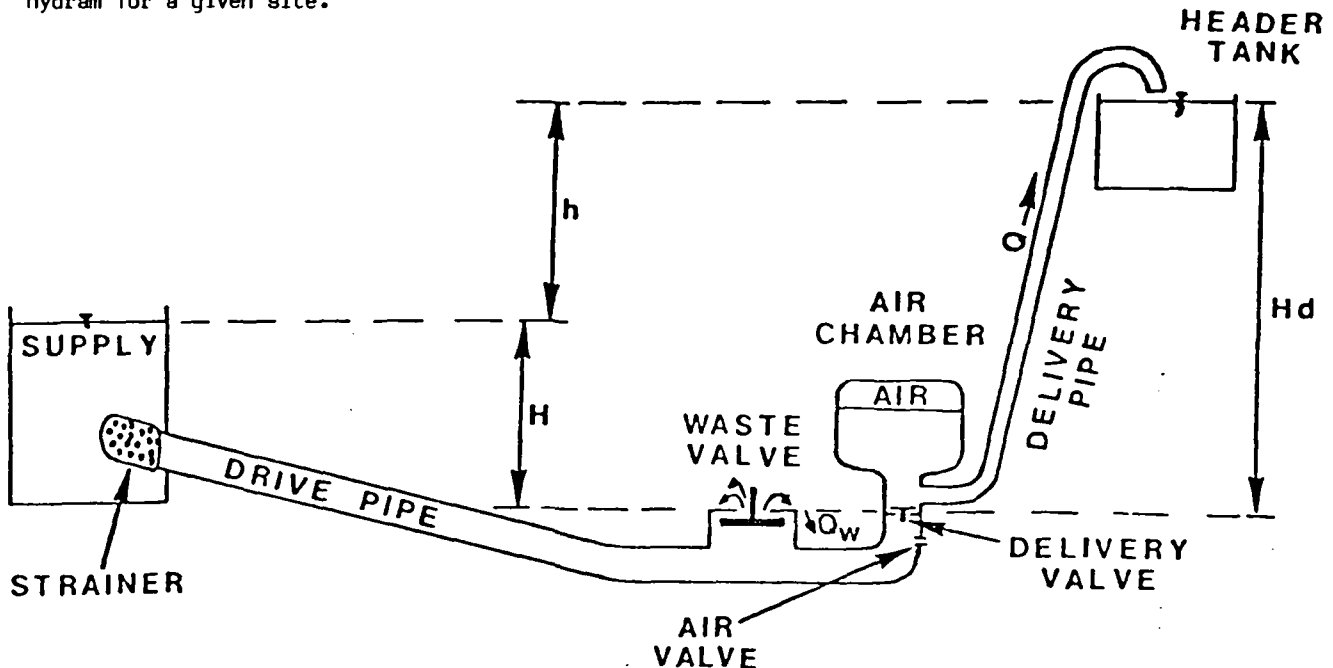
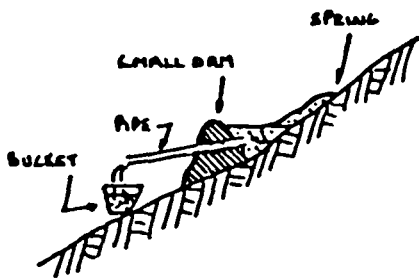

FIGURE 1: A TYPICAL ARRANGEMENT IN A HYDRAM INSTALLATION

### SITE PARAMETERS

A given site will have the following parameters which will usually need to be measured in the field.

- i) Stream Flow. Stream flows can be measured by various methods including the volumetric method for very small flows.



a.) MEASURING A SMALL FLOW.

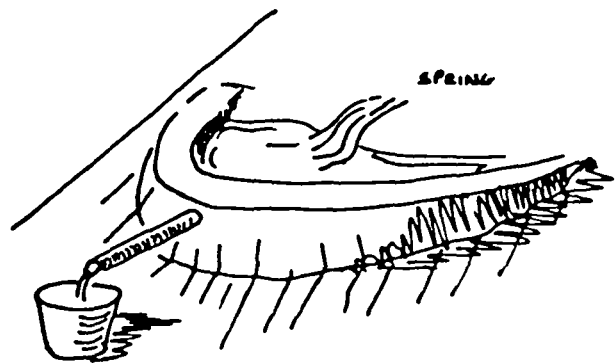

and the temporary V-notch weir for larger flows.

Watt (1978)

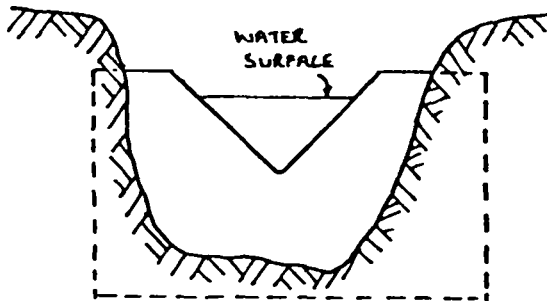

TEMPORARY DAM WITH V-NOTCH.

b.) MEASURING LARGER FLOWS

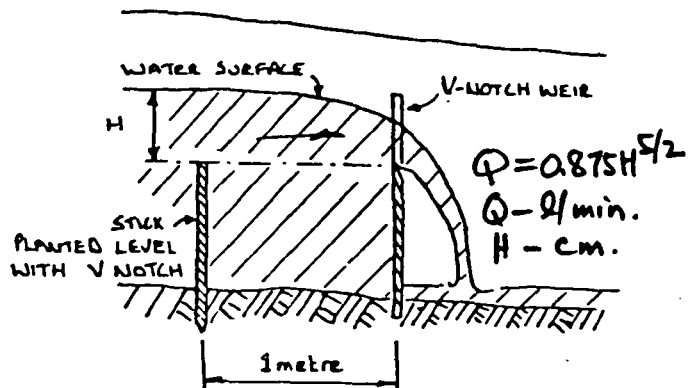

MEASUREMENT OF WATER DEPTH H ONE METER UPSTREAM FROM V-NOTCH WEIR. Watt (1978)

For even larger flows, velocity measuring meters (either the pygmy type or the large Price and Ott current meters) can be used. Sufficient readings of the stream flow should be taken in a yearly cycle to determine the minimum guaranteed flow available ( $q_{\min}$ ).

- ii) The drop in the flowing stream from the source to the site of the hydam is an important parameter. The stream may have a natural drop or a drop can be created by means of a small dam. The amount of this drop can usually be determined with a simple surveying level or even with a carpenter's level attached to a stick.

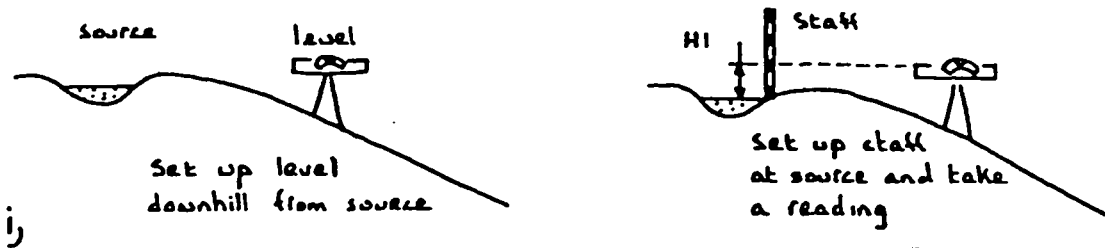

Katt (1978)

- iii) The distance from the hydam site to the storage point must be measured both in terms of the lift required ( $H_d$ , Figure 1) and in terms of the length of the delivery pipe required.
- iv) An estimate of the water demand is required. If this is to be used for domestic consumption in a rural setting, this can be approximated by:

$$\text{Water Demand} = \text{Population} \times \text{Per Capita Consumption} \quad (1)$$

A typical per capital consumption is 30-40 L/p/day. If animals are present, their water consumption should be included also.

#### MATCHING PUMP CHARACTERISTICS TO THE SITE AND DEMAND CHARACTERISTICS

Given the water demand from equation (1) and the fact that hydrams operate twenty-four hours per day, the required flow will be:

$$Q = \frac{\text{Water Demand (litres)}}{24 \times 60 \text{ (min)}} \quad (2)$$

We next refer to curves of pump efficiency for the same supply head, H, as was measured at the site. We should select a pump that works near its maximum efficiency at the flow given in equation (2). Curves derived by a computer model will greatly facilitate the pump selection process.

When a pump has been selected, the head ratio-flow ratio curves can be consulted. The pump will need to supply enough pressure head to lift the water to the storage tank and to overcome all friction losses in the delivery pipe. In general, this will be equal to:

$$\text{Delivery head} = H_d + \left( \frac{fL}{D} + E_k \right) \frac{V^2}{2g}$$

- where  $H_d$  = height to which water is lifted  
 $f$  = pipe friction factor  
 $L$  = delivery pipe length  
 $D$  = delivery pipe diameter  
 $V$  = average velocity in delivery pipe  
 $E_k$  = sum of various minor losses in delivery pipe  
 $g$  = acceleration due to gravity

Once the required delivery head is determined, the head ratio can be determined. From the head-ratio versus flow-ratio curve, the flow ratios ( $Q/Q_w$ ) can be determined. The sum of the delivery flow and waste flow must be less than the minimum guaranteed stream flow, i.e.

$$Q + Q_w < Q_{\min} \quad (3)$$

Highly efficient pumps reduce  $Q_w$ . If the stream flow is abundant, the hydam choice may emphasize durability more than efficiency.

#### HYDRAM SITE CONSTRUCTION

In most cases a small dam will need to be built. The drive pipe must enter the dam high enough from the bottom to avoid settled debris that will accumulate at the bottom of the headpond. The drive pipe should be fitted with a screen mesh to eliminate debris that would enter the drive pipe. This would tend to increase the wear of the waste valve and the delivery valve.

The drive pipe should be well braced, for it will have a high pressure wave travelling up along it. Care should be taken to ensure that pipes will not resonate with the imposed beat frequency of the hydam. Finally, the hydam itself should be well mounted on a concrete pad, with provision made for proper drainage of the waste water away from the hydam and back to the stream source. This feature is essential, and any site that cannot allow proper drainage from the hydam site should not be chosen.

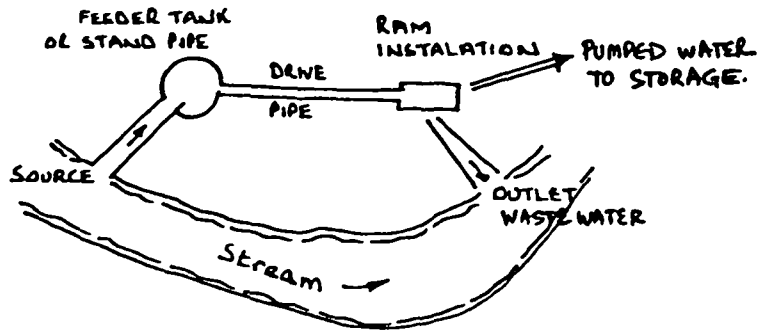

PLAN ON RAM INSTALLATION.

Watt (1978)

#### OPERATION AND MAINTENANCE

The hydam operates continuously with only two points of wear at the waste and delivery valves. Eventually, these valves will wear out and need replacement. Spare rubber disks should be kept on hand to repair these two valves when this occurs.

The drive pipe strainer should be checked periodically and cleaned as needed.

The air valve should be kept clear and clean. If air ceases to enter the hydam, very noisy and irregular operation will result.

Most hydrams can be tuned by varying the stroke of the waste valve. When hydrams are tuned they should be locked and not altered.

The above represent the major areas of maintenance. As long as the water supply is assured and the pump is kept free of debris, long periods of trouble-free operation can be obtained with hydrams.

#### REFERENCES

Watt, S.F. (1978). A Manual on the Hydraulic Ram for Pumping Water, Intermediate Technology Publications Ltd., London.

## THE MANUFACTURE OF HYDRAMS

S.S. Jandu

### ABSTRACT

Unrealistic approaches to local hydram design and manufacture are examined. Some aspects of the manufacture of hydrams in Tanzania are considered.

### INTRODUCTION

Jandu Plumbers Ltd. first began installing hydraulic rams in East Africa fifty years ago at which time the technology was already two hundred years old. The type of hydrams that Jandu has installed had previously been in manufacture for over seventy years. Therefore, our initial reaction on receiving an invitation to a seminar on the design and use of hydraulic rams was one of surprise that it should be necessary to do research into such a long-established technology.

We have seen hydraulic rams become beloved of the armchair Intermediate Technology (I.T.) and Appropriate Technology (A.T.) engineers for romantic rather than rational reasons. Indeed, it is partly for similar reasons that we manufacture them ourselves rather than some more profitable line. However, as engineers, we now see that the problems of making this sort of technology available to the rural population as a whole, are more social or even political than technical. We shall be happy to leave this aspect to the experts but would like to comment on one example of the naive application of the I.T. attitude. You will all have seen the neat hydram made from standard pipe fittings and adopted by VITA. Now - this is very convenient for the volunteer with the VITA handbook working in a remote area and with access to those fittings, but do we foresee hundreds of villagers descending on their nearest town to purchase fittings and then making and installing the ram in the village? We contend that it is much more likely that such technology will spread if appropriate equipment is readily available at the local market town at reasonable prices. Tanzania is, we believe, not untypical of many developing economies in its lack of spare parts and equipment. If you were to set out to build the VITA ram here, you would spend considerable time searching for the parts and should you be fortunate enough to find them, then the open market value of the components would be quite high since they will have been imported into the country, and consequently be a foreign exchange cost to the country. If you add this to the time and expense of searching and assembling, then the cost is considerable. Surely then, it is better to make available a commercially-built ram, or better still, to encourage the local manufacture of a hydram.

We hear a great deal about the "transfer of technology". In our experience this is greatly aided by having a foundry since this has enabled us to find equipment that has served its purpose and been well proven over the years and then, quite frankly, we copy the design.

We have been tempted to search for the most "efficient" hydram but now realize that it is more important that the machine selected should be cost-effective in terms of first cost and maintenance and that it should tend to keep working even when the conditions are not optimal. We selected our pattern of hydram because it is simple in having no metal moving parts, no bearings and no springs.

Our foundry has been built up over the last six years around the manufacture of the hydram but has diversified into many other items in our line of water supply and plumbing equipment. Our hydrams are made from locally-available scrap which is selected into different grades for different tasks and even the rubber valves are made locally by our supplier in Tanzania. Not only the hydrams, but also the foundry is made from local materials with the exception only of some electric motors and fire cement. We would not expect a foundry to be supported by the manufacture of hydrams alone and it is a further advantage of foundry work that once the cost of patterns has been covered, it is not expensive to change from the manufacture of one item to another to meet current demand.

One of the greatest aids to our type of small scale manufacturing industry would be the ability to buy secondhand machine tools from Europe where machinery that would be invaluable to us are frequently broken up for scrap. We have been lucky that through the good offices of the Ministry of Industry, we have been able to do this on one occasion and the machinery has been in full production ever since. The potential for industrial development by such means is huge, but the restrictions on importation of secondhand machinery makes it extremely difficult.

Our customers have included: aid agencies working in rural development, mission hospitals, schools, agricultural research stations, and many farms and plantations. If financing were readily available, villages would also buy direct. Incidentally, we know there is a well-developed demand for the hydrams - from the number of thefts that are reported to us.

I invite you all to visit our workshop and also see some of the hydrams that we have installed in the Arusha area. From this, you will have a better idea than I am able to convey in a speech, of the performance of the hydram and the problems we face in manufacture.



Jandu hydrants and a VITA hydrant on display at Jandu Plumbers Ltd., Arusha, Tanzania



The foundry at Jandu Plumbers Ltd, Arusha, Tanzania



**COMMUNITY PARTICIPATION IN THE DEVELOPMENT AND MAINTENANCE  
OF HYDRAMS IN RURAL WATER SCIENCES**

**L.G. Msimbe**

**ABSTRACT**

A historical review of the role of community participation in rural water supply in Tanzania is given. Possible areas of local participation in a hydram development program are given.

**INTRODUCTION**

Community participation in the development and maintenance of hydrams in water schemes has to be seen as an integral part of the beneficiaries' involvement in the total development of public services given to the rural populace, such as health centres, schools, roads, water schemes, etc. During the struggle for political independence, and as a result, in the early years of independence, mass mobilization was quite high. As a result, in the early years of independence, people's participation in what was then popularly known as self-help development programs was remarkably high. The success of the famous 'MTU NI AFYA' (a person is his health) campaign in the sixties and the number of schools, dispensaries, and health centres built during that time on a self-help basis clearly demonstrated the spirit people had towards development programs. In a nutshell, people had accepted that development was their own responsibility and that there would be no outside group who would help them in the transformation of their lives.

**LOSS OF MOTIVATION**

However, as years went by, that spirit progressively faded away. Although there are many factors which led to this change of attitude, the following are a few of the main ones:

1. Government involvement in the implementation of development schemes assumed a predominant role. The introduction of big development programs necessitated institutional management, and involvement of beneficiaries was ignored under the pretext of achieving the objectives within a predetermined economic timeframe. Planners felt that involvement was a parameter that they could not control.

2. The removal of local government authorities in the early seventies meant development programs would be more centrally planned and executed.
3. Some of the political decisions were misunderstood by the general public to mean the government was duty-bound to provide the basic public services free.
4. The second half of the sixties and first half of the seventies were very 'rosy' times and the government seemed financially able to assume the role of providing for the basic needs to its rural populace.
5. Some government decisions disturbed the order in society to the extent that people could not really identify their role in the development of their country.
6. Some individuals misused the existing potential of community participation for their own benefits. Incidences are on record where people were persuaded to put effort into projects which later had to be abandoned.
7. The present hard economic times characterized by shortages of many of the essential commodities has encouraged individualistic development.
8. Public participation was done on a voluntary basis. There was no legislation to enforce it and ensure its continuity as a necessary input in the development process.
9. There was no assessment made to evaluate the social and economic impact of community development on development programs.

#### **RESTORATION EFFORTS**

In the course of time, the government realized its limitations in terms of resources and implementation capacity. More importantly, the government realized that development cannot be 'planted'. Beneficiaries' involvement is a necessary input if development programs are to be real and meaningful. Therefore, the government is now taking positive steps to restore the apparently lost glamour of local participation. As a first step, the government encouraged formation of village governments which will manage funds and provide public services. The process of village legislation has been regrettably slow. The establishment of local government in 1983 is also seen as a positive contribution towards reactivation of the self-help spirit, although it also has some undesirable features like personal tax.

As evidence of a new trend, a department of community participation has been established in the prime minister's officer.

**COMMUNITY PARTICIPATION POTENTIAL IN HYDRAM SCHEMES**

Regarding the development and maintenance of hydrams used in rural water schemes, the following tables indicate areas of possible beneficiaries' involvement.

**TABLE 1: CONSTRUCTION**

Activity	Community Involvement
Site identification	+
Community mobilization	+
Survey	x
Design	x
Supervision of construction work	x
Materials (local)	+
Materials (foreign)	x
Skilled labour	x
Unskilled labour	+
Installation	*
Construction	+

**TABLE 2: OPERATION AND MAINTENANCE**

Activity	Community Involvement
Protection	+
Attendance	+
Running expenses	x
Repairs	+
Reporting	+
Ownership	+

NOTE: + - implies participation possible  
x - participation is not possible  
\* - limited participation

Table 2 clearly demonstrates that there is a large scope of community involvement, particularly in the operation and maintenance of hydrams.

## CONCLUSIONS AND RECOMMENDATIONS

The need for community participation in development programs cannot be overemphasized. At present, it is difficult to organize community participation. Therefore, there is a need to conduct a study to ascertain the level of community participation that would be possible in the development and maintenance of hydrams. The main objectives of the study should be the following:

- identification of options which will reactivate the spirit of community participation, particularly in the development and maintenance of hydrams;
- determination of cultural influences on the acceptability of hydrams;
- assessment of attitudes of people towards water supply services;
- assessment of local skills and their influence on the development and maintenance of hydrams;
- assessment of the level of need of service; and
- determination of the influence of economic differences in the development and maintenance of hydrams.

## **SOCIO-ECONOMIC CONSIDERATIONS IN RURAL WATER SUPPLY DEVELOPMENT**

**W. Baynit**

### **ABSTRACT**

Some cultural constraints to hydram usage are noted. The difficulty with fossil-fuel pumping is enumerated and potential areas for hydram development in Tanzania are listed. Some aspects of a hydram feasibility study are given.

### **INTRODUCTION**

Constraints to the application of any technology should not necessarily be confined to technical aspects. Social and even political aspects may be crucial in constraining the demand for a technology. This is true for hydrams as well as any other technology.

### **SOCIAL CONSTRAINTS IN HYDRAM APPLICATION**

When discussing the social constraints in the application of hydrams in Tanzania, a major issue may be the potential users' lack of awareness and exposure to hydram technology in areas where this technology could be used. Other social and economic barriers could include: excessively high capital costs, users' cultural barriers and sensitivities, social structure of the users' community-like settlement patterns, ownership pattern, government policies, and economic aspects such as inflation.

One of the main cultural barriers and sensitivities of the rural communities in Tanzania as well as in most other African countries, is superstition. The unique sound that hydrams make while working could trigger some speculation among the villagers. Some hydrams are installed in strange-looking areas and left unattended. There are thus no visible paths leading to them and yet the sound reaches quite a distance. This may make the villagers suspicious and refuse to accept the hydram as a useful tool. It is a commonly-held belief that the natural water sources like springs are holy places and should not be tampered with. Experience has shown that, in some cases, villagers will not only abandon the area in which the pump is installed but also the river from which the hydram draws its water. Villagers would rather look for an alternative water source which may be miles away than draw their water from a tampered-with or "bewitched" river or spring. This problem will be resolved through exposure to various working hydrams and education.

## POTENTIAL FOR WIDESPREAD USE OF HYDRAMS

Following the campaign to settle peasants in Ujamaa (communal) villages, a number of water pumps were installed to supply water to these villages. Most of the pumps were driven by fossil-fuel engines and a few by windmills. The pumps were installed at a time when the world was about to bid farewell to the cheap fuel era. The villagers did not enjoy piped water for long before the oil crisis struck. For some time more pumps continued to be installed as the world expected the crisis to be temporary but only recently has it been realized that the cheap oil era is gone forever.

With the ever rising prices of fossil-fuel and spares, the engines one by one ground to a stop. Villagers who could afford the fuel and spares lacked the expertise to repair and maintain the engines. The last blow came when fuel was in short supply and rationing was introduced. It became very difficult for villagers to obtain the fuel although some had the money to buy it. The pumps were abandoned with unserviceable engines and the villagers had to revert to trekking miles in search of water. The situation is still the same today and there is no indication of ever reviving the engines again. In fact, some of the engines have been brought back to towns where they are driving other machines, including grain mills.

Windmills have been used to pump water in Tanzania but the initial costs of purchasing and installing them are out of reach of most villages. The few seen here and there in some parts of the country were bought by the government and installed free-of-charge to the villages. Even a government cannot afford to supply a windmill free-of-charge to every village in the country. Even with the few windmills supplied by the government, most of them are either not working or the pumps are not working due to lack of regular maintenance.

The hydram, therefore, is the ideal alternative to the pumps mentioned above. The fact that it consumes no fossil-fuel, needs minimum maintenance and can be reasonably priced, weighs heavily in its favor. As mentioned earlier, the technology is quite simple and all the hydrams which may be required can be manufactured locally. This will serve two purposes. Firstly, foreign currency can be saved, and secondly, the end users will have somewhere to turn in case of problems.

There are many areas in Tanzania where hydrams could be installed both for domestic and irrigation purposes. The Northern Highlands with fast-flowing rivers are quite ideal. It is in this area that some of the oldest hydrams were installed many years ago; some of them can still be found in working condition. The Southern Highlands have numerous rivers running in deep ravines formed by low hills. Dwelling houses are built on the hills making it difficult to fetch water up the hills. Some hydrams can be found in this area also.

The Usambara Mountains are another potential area for installing hydrams. The area has plenty of rivers with many waterfalls but most of the rivers run deep between steep, low hills thus creating a problem of fetching water uphill. In the Uluguru Mountains, people live on the slopes and a lot of rivers run down the slopes to the sea many miles away. As in the Usambara, here also hydrams could be useful to lift water to the dwellings. The people living in these areas are good cultivators of vegetables but they have difficulty in bringing water to the high ground where they live and farm.

#### **CONCLUSION AND RECOMMENATION**

In Tanzania the experience of the failure of the engine-powered pumps should give all those concerned a new outlook in rural water supply. The fact that a hydram uses no fossil fuel and has the ability to work continuously for up to fifty years with minimum maintenance, confirms the appropriateness of the pump. The experience of owners of hydrams installed around Arusha after the cheap oil era proves further that hydrams have a future in this country.

It is true that the initial cost of the pumps and installation is rather high and beyond the reach of most individuals. For domestic purposes, one hydram can supply water to a sizeable community provided the storage tank is big enough. The cost, therefore, will be spread among all potential users.

To promote the widespread use of hydrams in Tanzania, a feasibility study, especially of water sources available and socio-economic aspects, must be made. The recommendations mentioned below may prove useful in this respect.

1. A study on the use of hydrams should be carried out to find out the actual potential for these devices. This will include water sources and the geographical and socio-economic aspects.
2. Efforts should be made to enhance the manufacture of hydrams within the country. More entrepreneurs should be encouraged to use their facilities for this purpose. The small scale industries which have been established in various parts of the country could be most useful for this purpose.
3. Institutions such as CAMARTEC should be charged with the responsibility of selecting and evaluating a few proven designs which can be manufactured locally.

4. The technology must be disseminated in the rural areas by launching a nation-wide campaign. A few demonstration pumps could be installed in selected areas and villagers should be encouraged to meet all expenses.
5. Owners should be trained to adjust the hydrams and to change worn-out working parts. This also could be done by CAMARTEC or the manufacturers. Other maintenance aspects of the hydram should also be taught to the owners.
6. Villages now are bigger and more populous than before the Ujamaa villages. This calls for larger size hydrams, as these will be cheaper than a number of smaller ones.



FIELD TRIP PHOTOS



Twin-acting hydram in the Arusha area



Jandu Hydram, operating in the Arusha area

## THE THEORY AND DESIGN OF THE AUTOMATIC HYDRAULIC RAM PUMP

P.O. Kahangire

### ABSTRACT

The automatic hydraulic ram pump and its generalized action are briefly described. The basic methods commonly used to study the principles of hydraulic ram operation are summarized. A simple approximate analysis of the operation of the hydraulic ram pump and the resultant operating characteristics are derived and presented. The theoretical hydram model results are then compared with experimental results for two hydrams.

The influence on hydram performance by (i) design features of the hydram itself, and (ii) such external parameters as the supply head, drive pipe length and velocity of water in the drive pipe are discussed. Finally, topics for further research are examined.

### INTRODUCTION

#### The Automatic Hydraulic Ram

A hydraulic ram pump (hydram) is a unique device that uses the energy from a stream of water falling from a low head as the driving power to pump a portion of the water to a head much higher than the supply head. With a continuous flow of water, the hydram will operate automatically and continuously with no other external energy. Hydrams are suitable for small scale water supply schemes, farmhouses and isolated settlements (Schiller 1982).

The hydram is structurally simple consisting of two moving parts: the waste valve and the delivery (check) valve. There is also an air chamber and in most hydrams, an air (snifter) valve. The operation of the hydram is intermittent due to the cyclic opening and closing of the waste and the delivery valves. The closure of the waste valve creates a high pressure rise in the drive pipe and hydram. The air chamber is necessary to prevent these high pressures in the delivery pipe and transform the intermittent pumped flow into a continuous stream of flow. The air valve allows air into the hydram to replace that absorbed by the water due to the high pressures and mixing in the air chamber.

## Hydrum Utilization

Hydrums can operate trouble-free for a long time and need no fossil fuels or other external source of energy other than the falling stream of water. They are mechanically simple and operate with relatively high efficiency and require only limited simple maintenance. In spite of all these advantages, the hydrums have not been utilized as much as they should. The hydrum has not been widely used partly because the detailed mechanics of its operation are not well understood. As a result, significant design improvements and variations have been difficult to make and the commercial hydrum remained almost the same for 190 years. The operating limitations of hydrums are also not well known. As a result, the commercial hydrum market remained small and reserved for small scale applications.

## **RESEARCH INTO THE PRINCIPLES OF HYDRAM OPERATION**

There have been many attempts to study and predict the hydrum operation. The studies can be divided into three main groups as follows.

### Empirical Methods

The method relied on experimental tests with results not supported or correlated by theory. The empirical formulations were of limited applicability and sometimes led to some 'rules-of-thumb', some of which were misleading. Empirical formulas were insufficient for the prediction of hydrum operation because the hydraulic ram operation depends on many variables, most of which were neglected in the formulas.

### Analytical Methods

Using the basic rules of hydraulics and fluid mechanics, attempts have been made to ascertain the rate of change of the variable velocity of water in the drive pipe during each phase of the cycle. From these analyses operating characteristics of the hydrum are determined (Bergeron 1928, Iversen 1975). The methods were not very successful because several parameters relating to the operation of the hydrum are best obtained experimentally. These parameters include loss of head by friction and turbulence through the waste valve, friction loss in the drive pipe and the delivery valve. Without these experimentally-determined parameters, the formulations become very complex and include parameters that are difficult to estimate.

Rational Methods

Methods based on theoretical analysis of the hydraulic ram, with some parameters determined experimentally have been verified by Gosline and O'Brien (1933), Lansford and Dugan (1941), Krol (1951), Kahangire (1984). This is so far the most successful approach to the study of the operation of the hydraulic ram pump.

**ANALYSIS OF THE HYDRAULIC RAM ACTION**

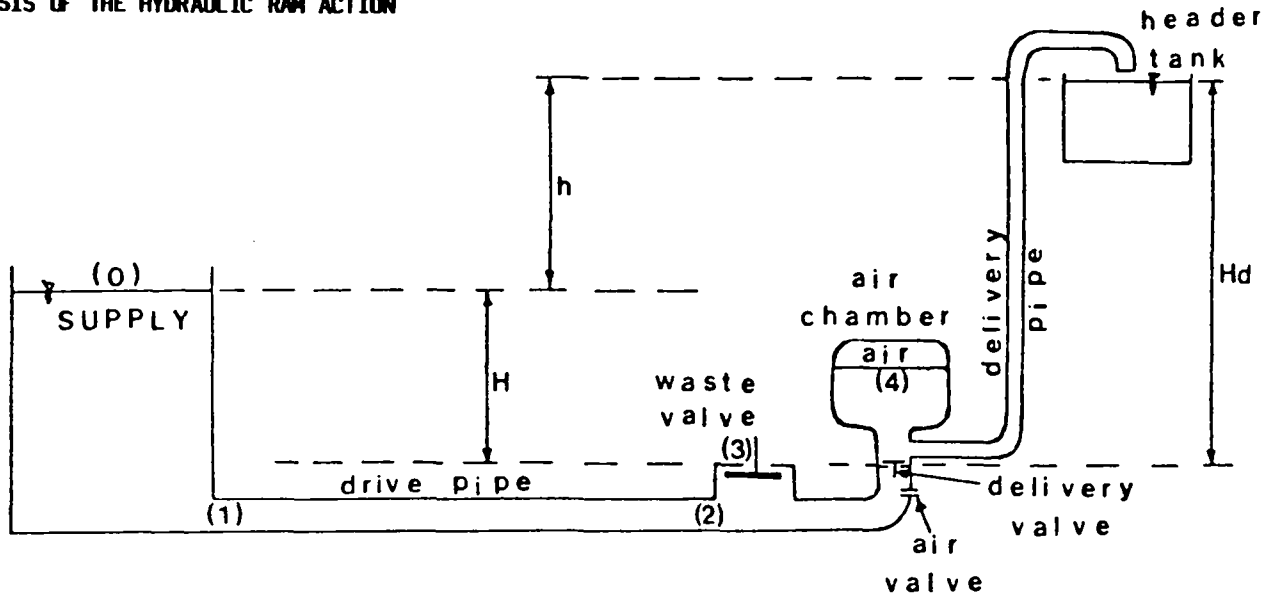

**FIGURE 1: TYPICAL HYDRAULIC RAM INSTALLATION**

Hydraulic Ram Action

The momentum produced by a flow of water from a low supply head,  $H$ , (Figure 1) is used to pump a small part of the flow to a higher head,  $H_d$ , above the waste valve opening. The rapid opening and closing of the waste and delivery valves creates pressure surges which are superimposed on the major effects of steady pressure differences and kinetic energy of the flow in the drive pipe. The pressure fluctuations create compression waves which, in turn, are superimposed on the velocity changes in the drive pipe. Considering all these effects would lead to a very complex analysis. Theoretical models that predict the hydram performance accurately are therefore lengthy and complex which reduces their usefulness to practical designers and users of hydrams.

The approximate analysis presented in this paper is based on the average effects of the supply head, atmospheric pressure, delivery head and frictional forces. Only the main effects of the hydam action are considered and the model derived is simple to understand and use. The major waterhammer effects are considered together with the friction head losses. The details of recoil and effects of elasticity of valve materials are neglected (Kahangire 1984). The analysis lies between the detailed analysis of Krol (1951) and the simplified analysis of Iversen (1975).

### Hydam Operation

For this simple analysis the pumping cycle of the hydam is divided into four main periods. The division is based on the position of the waste valve and the average time-velocity variation in the drive pipe (Figure 2).

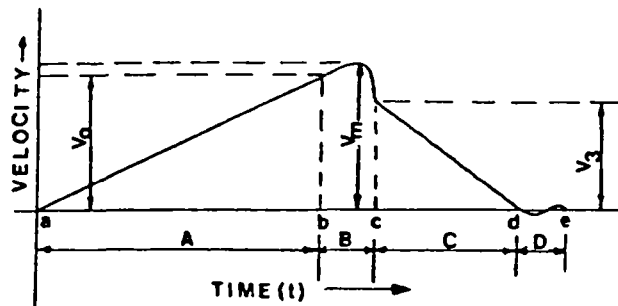

FIGURE 2: TIME-VELOCITY VARIATION IN THE DRIVE PIPE

- A. The waste valve is open and water starts to flow from the source and escapes through the waste valve. The flow accelerates under the effect of the supply head,  $H$ , until a velocity  $V_0$  is attained in the drive pipe. At this velocity, the total drag and pressure forces on the waste valve equals its weight and thereafter the valve begins to close.
- B. The waste valve continues to close and is finally fully closed. For a good hydam design, the valve closure is rapid or instantaneous.
- C. The waste valve is fully closed and remains closed. The sudden closure creates a high pressure in the hydam and on the check valve that is in excess of the static delivery pressure. The check valve is forced open and pumping takes place until the velocity becomes zero and pumping stops, under the retarding effect of the delivery pressure head.

D. The delivery valve closes. The pressure near the check valve is much higher than the static supply pressure and the flow is reversed towards the supply source. This action is termed recoil. The recoil action creates a vacuum in the hydram, temporarily forcing a small amount of air to be sucked into the hydram through the air valve. The pressure on the underside of the waste valve is also reduced and together with the effect of its own weight, the waste valve opens automatically. The water in the drive pipe returns to the static supply pressure as before and the next cycle begins. The action is repeated automatically at a frequency of a few beats to over 300 beats per minute.

#### **THEORETICAL MODEL OF THE HYDRAULIC RAM**

At the University of Ottawa, a computerized theoretical model based on the assumed cycle of operation given in the previous section was developed to assist in deriving the operating characteristics of any given hydraulic ram pump. The computer program listing was originally given in Fortran language but has now been converted to Basic language for use on microcomputers.

The development of the model is based on the following assumptions:

1. Approximate one-dimensional steady flow equation is applicable for the flow in the drive pipe.
2. The friction losses in the drive pipe and pump do not vary with the variation in velocity but are constant. Therefore, the parameters determined under steady flow conditions are approximately constant.
3. The waste valve closure is instantaneous.
4. The velocity of water in the drive pipe when the waste valve begins to close and that when the waste valve is finally close are almost the same.
5. The resistance due to spindle movement through the valve guide is negligible and constant.
6. Only the average flow velocity and pressure difference variations in the system are considered.

In order to use the derived model, the following parameters need to be obtained (some experimentally) from the hydram design and installation. These include: (a) drive pipe length (L); (b) cross-sectional area of the drive pipe; (c) drive pipe diameters and thickness; (d) supply head (H); (e) delivery head (h); (f) friction head loss in the drive pipe alone (XM); (g) friction losses through the waste valve alone (RS); (h) friction head loss at the delivery valve (HVD); (i) the velocity in the drive pipe when the waste valve begins to close ( $V_0$ ); and (j) the steady flow velocity ( $V_g$ ) through the waste valve when fully open.

#### COMPARISON OF OBSERVED AND COMPUTER MODEL RESULTS

The theoretical hydram model derived above was tested against experimental results from two 1½ inch (32mm) hydrams, one of which was made locally from steel pipe fittings. Various experimental test results were done for a supply head of about 2m, stroke lengths between 1mm-12mm and drive pipe length of 15.5m (Kahangire, 1984). For a typical run,  $V_g$ , M, N,  $V_0$ , HVD and XM were determined experimentally under steady flow conditions. The results presented here are for the locally made hydram with a valve weight of 0.36N, valve stroke length of 2mm, and drive pipe length of 15.5m. For this test run, the following parameter values were obtained and used in the model:  $V_0 = 0.40\text{m/sec}$ ;  $M = 69$ ;  $N = 69$ ;  $HVD = 70$ ; and  $XM = 12$ . The comparison of the observed and model results is shown in figures 3, 4, 5 and 6. This pattern of agreement was observed in the other tests with the locally-made hydram and the commercial hydram (Davey model 4) (Kahangire, 1984).

#### PRACTICAL ASPECTS OF HYDRAM DESIGN AND INSTALLATION

##### Efficiency

There are two methods commonly used to compute the efficiency of a hydram installation; the Rankine and the D'Aubuisson methods, both of which were proposed by Eytelwein (Mead 2933, Calvert 1957). The difference depends on whether the surface elevation of the water source or the waste valve opening is taken as the datum.

$$E \text{ (Rankine)} = \frac{Q \cdot h}{Q_w \cdot H} \quad (1)$$

$$E \text{ (D'Aubuisson)} = \frac{Q \cdot Hd}{(Q+Q_w)H} \quad (2)$$

Where  $Q$  is the pumped flow per minute,  $Q_w$  is the wasted flow per minute,  $h$  is the pump head above the source,  $H$  is the supply head above the waste valve opening and  $H_d$  is the total delivery head above the waste valve opening (Figure 1).

For practical purposes, it does not matter which formula is used. The two equations give slightly different results and any references to hydam efficiency values should indicate the method used. The D'Aubuisson formula gives higher values. It also has the shortcoming of giving efficiency values even when no useful work is done by the pump. For field tests and practical applications, the Rankine definition of efficiency is to be preferred.

Some empirical formulas have been suggested based on experimental tests. Eytelwein with data from over 1100 experiments from two different hydrams derived the following equation for hydam efficiency

$$E = 1.12 - 0.2 V \frac{h}{H} \quad (3)$$

(Cleghorne 1919). Another one by D'Aubuisson was of the form

$$E = 1.42 - 0.28 V \frac{hd}{H} \quad (4)$$

(Anderson 1922) where  $h$  and  $H$  are as defined earlier. These equations relate to the specific hydrams tested. They also indicate the general nature of the efficiency curves for these types of pumps and show how efficiency reduces as the pump head increases for a given supply head.

#### Drive Pipe Specifications

The drive pipe is an important component of the hydam installation. The drive pipe must be able to sustain a high waterhammer pressure caused by the closing of the waste valve. Its diameter depends on the size of the hydam, strength requirements, cost considerations, availability of pipe materials and, in some cases, the available supply flow.

In spite of several experimental investigations, there is no agreement as to what length of the drive pipe should be used. The drive pipe length should depend on the supply head and its own diameter. The length commonly used in Europe and North America lies between the limits



6HCL12H (Krol 1951). Eytelwein suggested an empirical relationship to determine drive pipe length

$$L = h + 0.3 \frac{h}{H} \quad (5)$$

(Weisbach and Herrmann 1897).

Russian researchers derived an empirical formula to determine suitable drive pipe length (L) as

$$L = \frac{900 H}{N^2 D} \quad (6)$$

where D is the drive pipe diameter and N is the number of valve beats per minute. Calvert experimentally determined the limits of suitable drive pipe length as

$$150 \leq \frac{L}{D} \leq 1000 \quad (7)$$

Outside these limits the pump will not work properly. On the basis of analytical studies, for the pump to operate continuously and automatically, the drive pipe length (L) should lie between the limits

$$0 \leq L \leq D \left[ \frac{C_d A_v j H - W(1 + E h_1 + RS)}{W_f} \right] \quad (8)$$

(Krol 1951, Kahangire 1984). For practical purposes, Calvert's equation gives better guidelines since it takes into account the size of the drive pipe.

Due to the high pressures involved, the drive pipe is usually made of steel or cast iron. Other materials can be used but will not give as good results as steel in terms of the delivery pressures that the pump will develop. The pipes must also be sufficiently thick (Figure 3) to withstand the high waterhammer pressures that are generated (Watt 1975).

In a recent study, Kahangire (1984) used a theoretical computerized model to investigate the effects of drive pipe length on hydram operation. By varying the length between 1 m and 121 m, the following effects were observed: Increasing drive pipe length slightly reduced peak pump efficiency, decreased pumped flow and peak power. Cycle duration was greatly increased by

40-50%. Generally, the length should not be too short as the valve will close very fast, often with no significant increase in water being pumped. If the length is very long, the friction head losses will dominate and reduce the pump capability. If the supply head is high and the drive pipe is long, the momentum of water in the drive pipe will be very high and the pump will be damaged. In that case, a stand pipe should be inserted along the drive pipe to reduce the effective supply head.

### Air Chamber

The effect of the air chamber size on hydram operation is not clearly known. Krol (1951) noted an increase of 10% in pump efficiency when the air chamber volume was doubled. Krol recommends the air volume to be approximately 100 times the volume of water delivered per cycle. Cheghorne (1919) recommended the volume to be approximately twice the volume of the vertical height of the delivery pipe. Experiments with a locally-made hydram from pipe fittings with a 2-inch (51mm) diameter pipe and lengths between 0.30 m - 1.3 m showed no significant effect of the air chamber volume on the operating characteristics of the hydram (Kahangire 1984). Inversin (1978) also found no effect of air chamber volume on hydram operation. Probably for high supply heads and long drive pipes, large air chambers and air volumes may be necessary to absorb the increased waterhammer pressures that will occur in the hydram.

### Air Valve

This is usually a small hole or a one-way valve. Experiments with different sizes indicate that the size has a negligible effect on the hydram operation. Only when the hole became so large that half of the pumped flow was escaping through it, did the effect become noticeable on hydram efficiency (Figure 4). The pump capacity, however, was not affected. A small hole less than 1.0 mm should suffice (Kahangire 1984).

### Design of the Waste Valve

A good waste valve design and proper adjustment are very essential for smooth and efficient hydram operation. The design details include proper proportioning of the valve opening or orifice area ( $A_o$ ) and the cross-sectional area ( $A_v$ ), its weight ( $W$ ) and the stroke length ( $S$ ) of the waste valve itself. The mechanism controlling the valve movement or valve guide should allow free and smooth movement. If good quality steel is not available, weighted impulse valves are more suitable than spring-type valves.

Common sizes of the waste valve are less than 4 inches (100 mm) and very few actually exceed 3-inch (75 mm). These sizes are considered more efficient while larger sizes are not (Richards 1922). Bergeron (1928) showed analytically that the flow area through the waste valve should equal or exceed the cross-sectional area of the drive pipe to avoid 'choking' the flow. In most commercial hydrams, the waste valve area  $A_v$  is usually bigger than the size of the inlet at the drive pipe-hydrum connection.

Experiments at the University of Ottawa with a locally-made hydrum indicated that there is a wide range of combination of  $A_D$  and  $A_v$  for which the hydrum operation was not affected for valve sizes not exceeding 70-75% of the valve 'pot' or 'housing' diameter (Figure 5). The experiments also indicated that changing valve stroke had a similar effect as changing the valve weight on hydrum operation. However, increasing valve stroke gave better and a smoother hydrum operation than increasing the weight. In general, increasing valve stroke or weight reduced pump efficiency (Figure 6) but increased the flow. The head ratio-flow ratio-curve remained the same (Figure 7). The effect of valve stroke on hydrum operation for well-designed commercial hydrums may be small. Changing the valve stroke length altered the characteristics of the valve (Figure 8) and the results indicate that hydrum operation may be more stable for stroke lengths greater than 4 mm. It was verified with the theoretical model that high friction losses through the waste valve are undesirable as they reduce the pump capacity (Figure 9) and affect its general operating characteristics. To minimize energy losses, the waste valve should be reasonably light and adjusted in such a way that it will close fast. It was shown analytically that for a given installation and valve design and stroke, the valve weight should lie within the limits

$$0 < W < \frac{C_d A_v j H}{M} \quad (9)$$

Krol (1976) indicated that there is a relationship between valve stroke ( $S$ ) and the maximum weight of the waste valve,  $W_{max}$ , that can be used, such that

$$SW_{max} = \text{Constant} \quad (10)$$

### Delivery (Check) Valve

Generally, the valve should be such that it opens fast, closes evenly and offers as little resistance to the flow as possible. As to its opening, Anderson (1922) recommends one square inch (6.54 sq cm) of area through the valve for every gallon (4.5 litres) of water to be delivered. Recent experimental studies with delivery valves made of a perforated plate and covered with a rubber disc of different thickness indicated that thin rubbers give high hydram efficiencies but weaken fast and have to be replaced quite often. The rubber tends to get sucked into the perforations and get cut due to the back pressure from the delivery pipe and air chamber. Increasing the rubber thickness affected hydram operation, primarily the pump efficiency (Figure 10). The theoretical model gave correlated results showing that the head losses through the delivery valve had their largest effect on hydram efficiency (Figure 11). For high supply and delivery heads, a thicker rubber will be necessary to withstand the back pressure and last long. In that case, the perforations could be enlarged to minimize the friction losses. It was noted in the experiment that except for very thick rubbers (10 mm) the pumped flow was not significantly affected (Figure 12).

### Supply Head

Increasing the supply head increases the velocity and momentum of water in the drive pipe. Inversin (1978) deduced from experimental results that with the simple weighted impulse valves, the supply head should not exceed 4 m, otherwise the valve will be closing so rapidly and frequently that no useful work will be done. In such a case, the valve should be assisted by a spring to regulate its closure. Experimental results indicated pump efficiency and pumped flow increased in direct proportion to the increase in supply head, particularly pump flow (Q). Power and valve beat frequency also increased. The theoretical model using supply heads of 2 m - 6 m indicated a big increase in peak pump efficiency and pumped flow. The cycle duration was greatly decreased. Therefore, depending on the waste valve design, stroke length and weight, there is a maximum supply head at which the pump will not work properly. There is also a minimum supply head necessary to operate the hydram.

### Velocity of Water in the Drive Pipe

The most important design parameter is the velocity at which the waste begins to close,  $V_0$ . Studies with the theoretical model (Kahangire 1984) indicated that this parameter is the most important for determining hydram operation (Figure 13 and 14). Therefore, any hydram design,

installation and adjustment conditions that affect the valve of  $V_0$ , will dramatically affect the general operating characteristics of the hydram.  $V_0$  is affected by the weight, stroke length, size and the general design of the waste valve.

## CONCLUSION

Many researchers have shown that with some assumptions and parameters determined empirically, the performance of the hydraulic ram can be predicted. Kahangire (1984) went further and demonstrated that the models can be used for preliminary design of hydrams and investigation of suitable hydram sites.

The mechanism of a hydram and its simple mechanical design and maintenance requirements make it a unique water-pumping machine potentially suitable for small scale water supply schemes in developing countries. Only a spring balance, stop watch and a calibrated cylinder or pail are sufficient to determine factors for the design of a simple efficient hydraulic ram pump. The computer program can also determine its performance curves.

Theoretical models can be used to predict hydram performance and can assist in the preliminary design and survey of possible sites for hydram use. The simple model developed has the capability of predicting the major characteristics of the hydram within acceptable errors. Some more work is needed to improve on its accuracy while still keeping it simple.

Information on practical hydram sizes and installation limitations is often not available. Such information is necessary to prevent expensive failures in the field and arbitrary hydram designs and installations. Computer programs can yield this information. This would lead to cost-effective hydram designs and installations.

LIST OF SYMBOLS

- A - cross-sectional area of the drive pipe
- $A_0$  - area of the waste valve orifice
- $A_v$  - cross-sectional area of the waste valve
- c - speed or celerity of an acoustic wave in water
- $C_d$  - dimensionless drag force coefficient
- E - modulus of elasticity of the drive pipe material
- e - mechanical efficiency of the pump
- f - friction factor of the drive pipe
- F - drag force on the waste valve
- g - acceleration due to gravity
- H - supply or drive head above the waste valve
- $\Delta H$  - change in pressure head due to waterhammer
- $H_d$  - total delivery head above the waste valve
- HVD - frictional head loss factor of the delivery valve alone
- h - pump head
- $\sum H_l$  - total minor losses in the drive pipe
- $h_r$  - head loss through the delivery valve during pumping
- $h_{max}$  - maximum pressure head the pump can develop
- K - bulk modulus of elasticity of water
- $K_c$  - composite modulus of elasticity of water and pipe material
- L - length of the drive pipe
- M - total head loss factor of both the drive pipe and waste valve
- m - velocity ratio =  $V_0/V_s$
- N - total head loss factor of both drive pipe and delivery valve
- P - pump power
- $\Delta p$  - change in pressure due to waterhammer
- Q - pumped flow rate
- RS - head loss factor the waste valve alone
- t - time in general
- T - total duration of the cycle of hydram operation
- $t_p$  - thickness of the drive pipe
- V - velocity of water in the drive pipe in general
- $V_0$  - velocity of water in the drive pipe when the waste valve begins to close
- $V_s$  - steady state flow velocity in the drive pipe

LIST OF SYMBOLS (continued)

- $V_m$  - the velocity of the drive pipe just before complete waste valve closure
- $\Delta V$  - change in velocity due to waste valve closure
- $V$  - flow volume per period of the cycle
- $W$  - maximum weight or spring tension of the waste valve
- $X_M$  - frictional head loss factor of the drive pipe alone
- $\gamma$  - specific weight of water
- $\rho$  - density of water

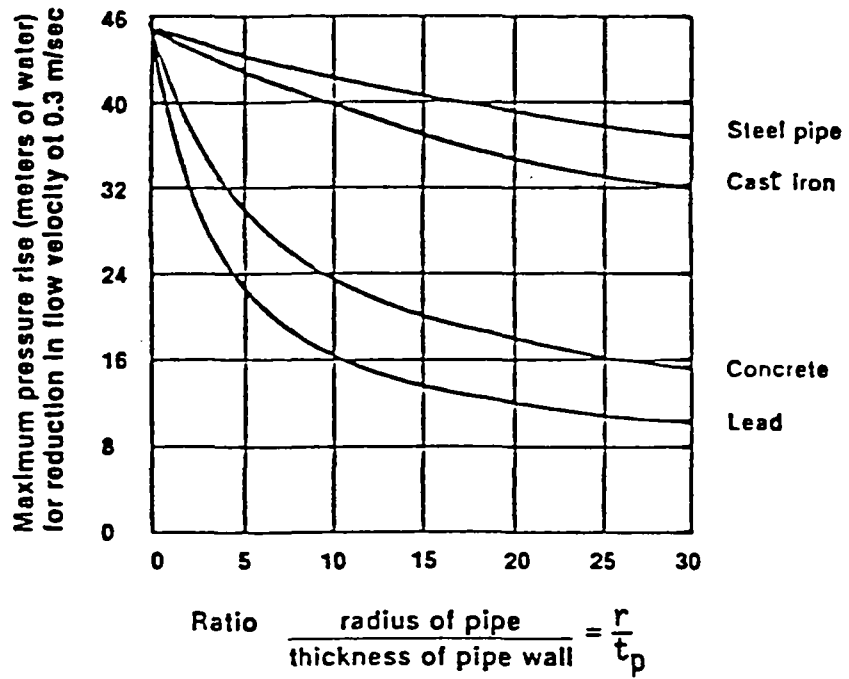

FIG. 3 DRIVE PIPE SPECIFICATIONS (Watt 1975)



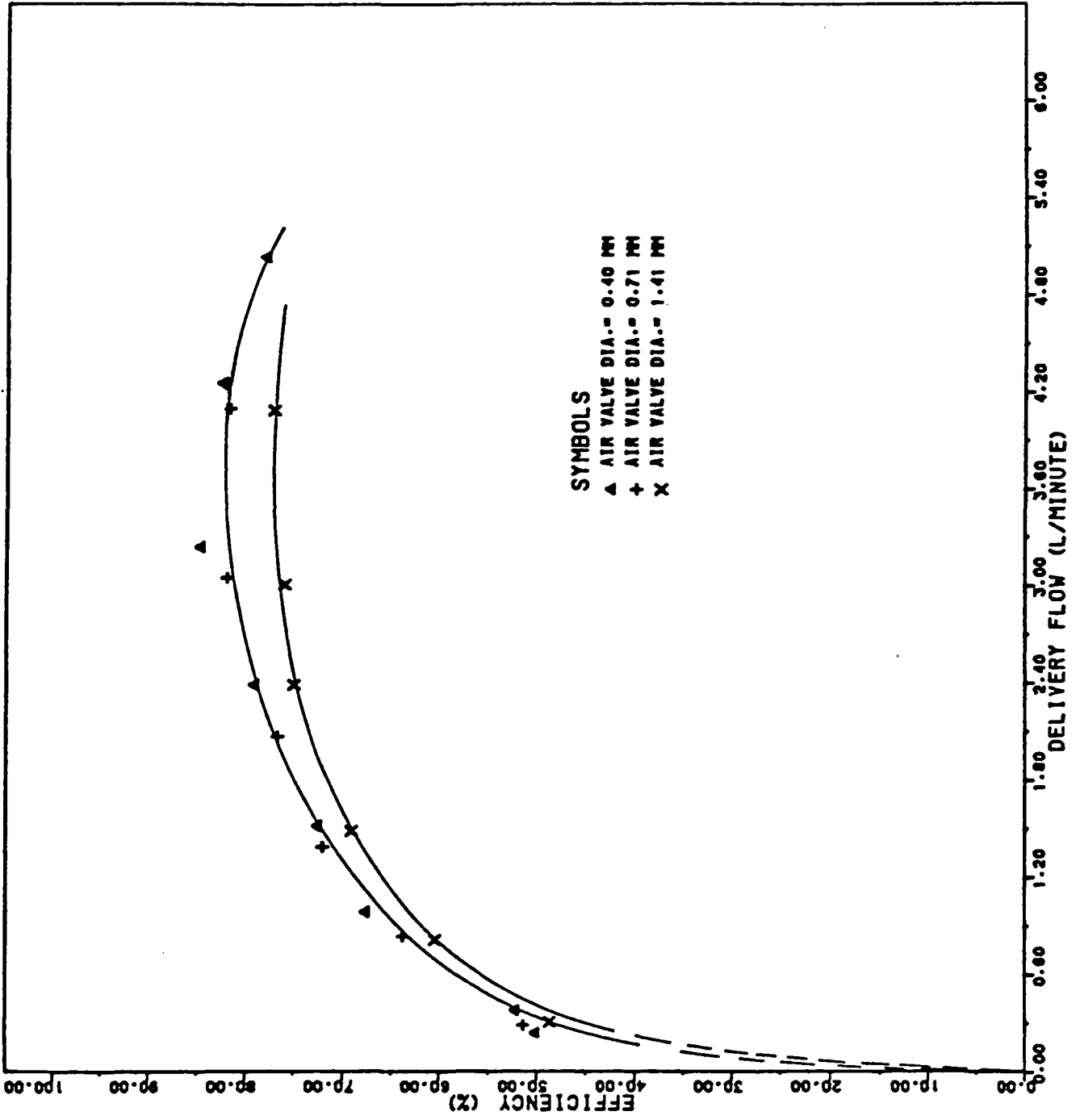

FIG. 4 ITDG (IMPULSE) HYDRAM: EFFECT OF AIR VALVE ON PUMP EFFICIENCY.

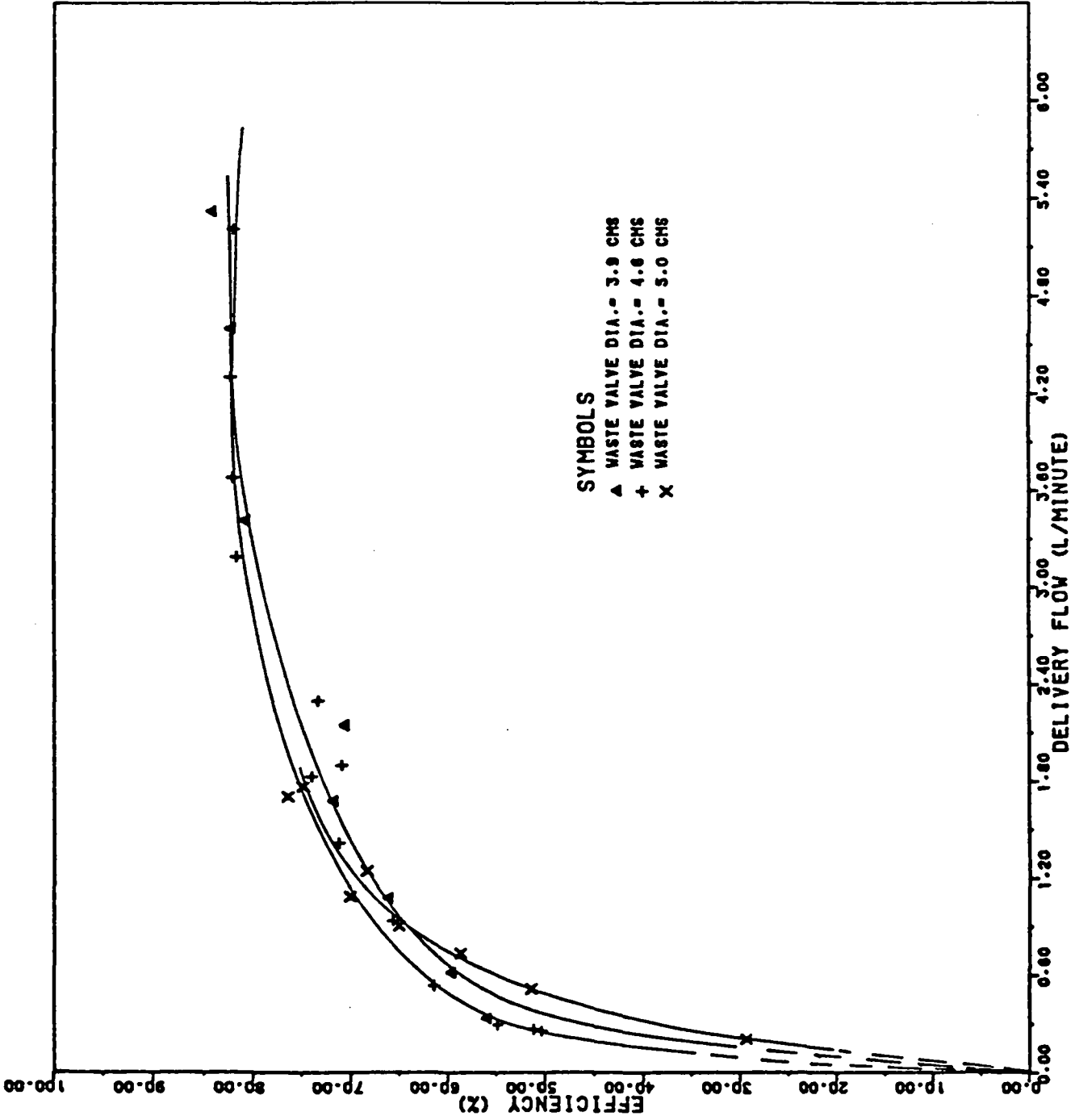

FIG. 5 ITDG (IMPULSE) HYDRAM. EFFECT OF WASTE VALVE DIAMETER ON PUMP EFFICIENCY. ORIFICE DIAMETER = 3.0 CMS

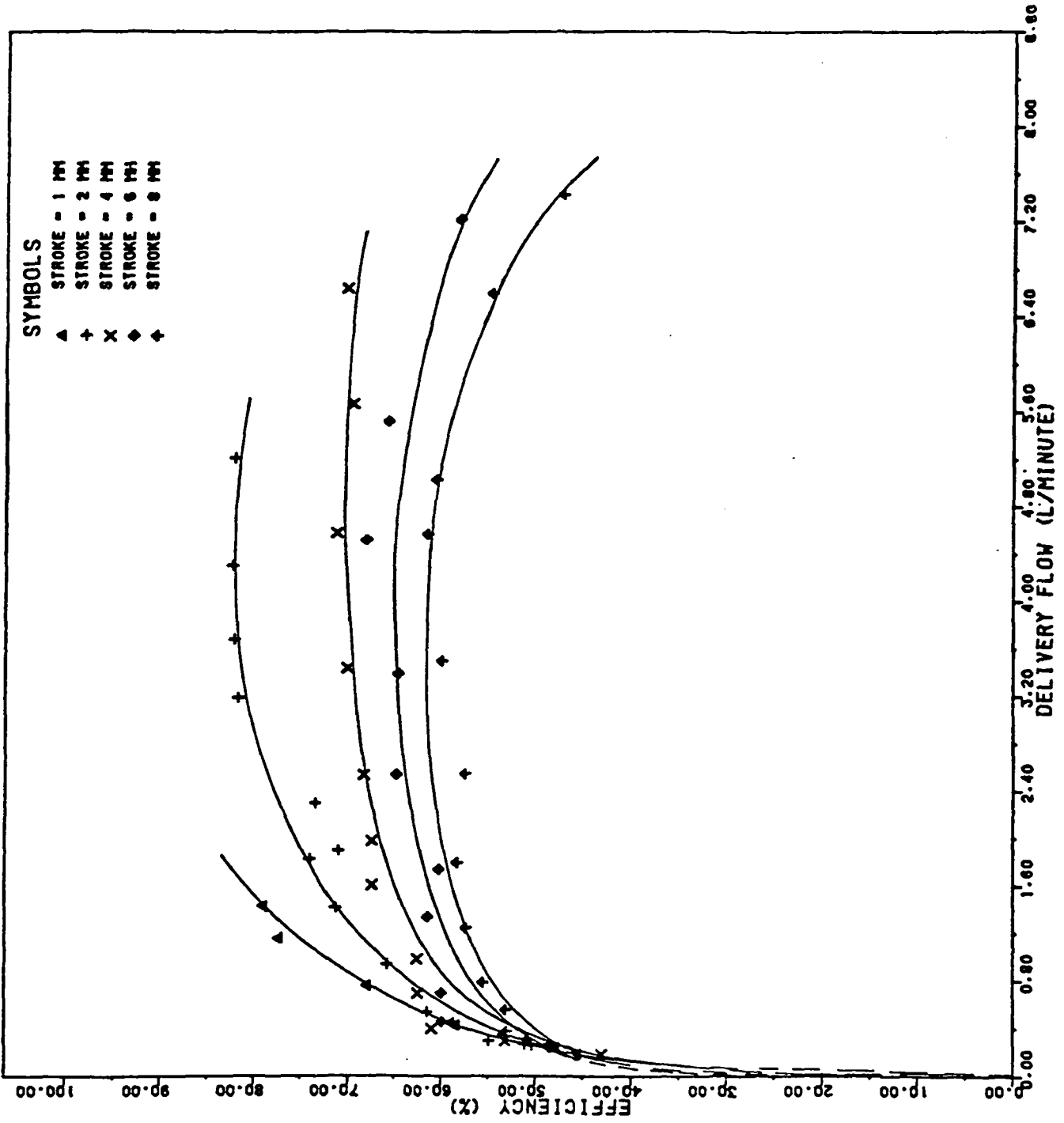

FIG 6 ITDG (IMPULSE) HYDRAM EFFECT OF VALVE STROKE ON PUMP EFFICIENCY

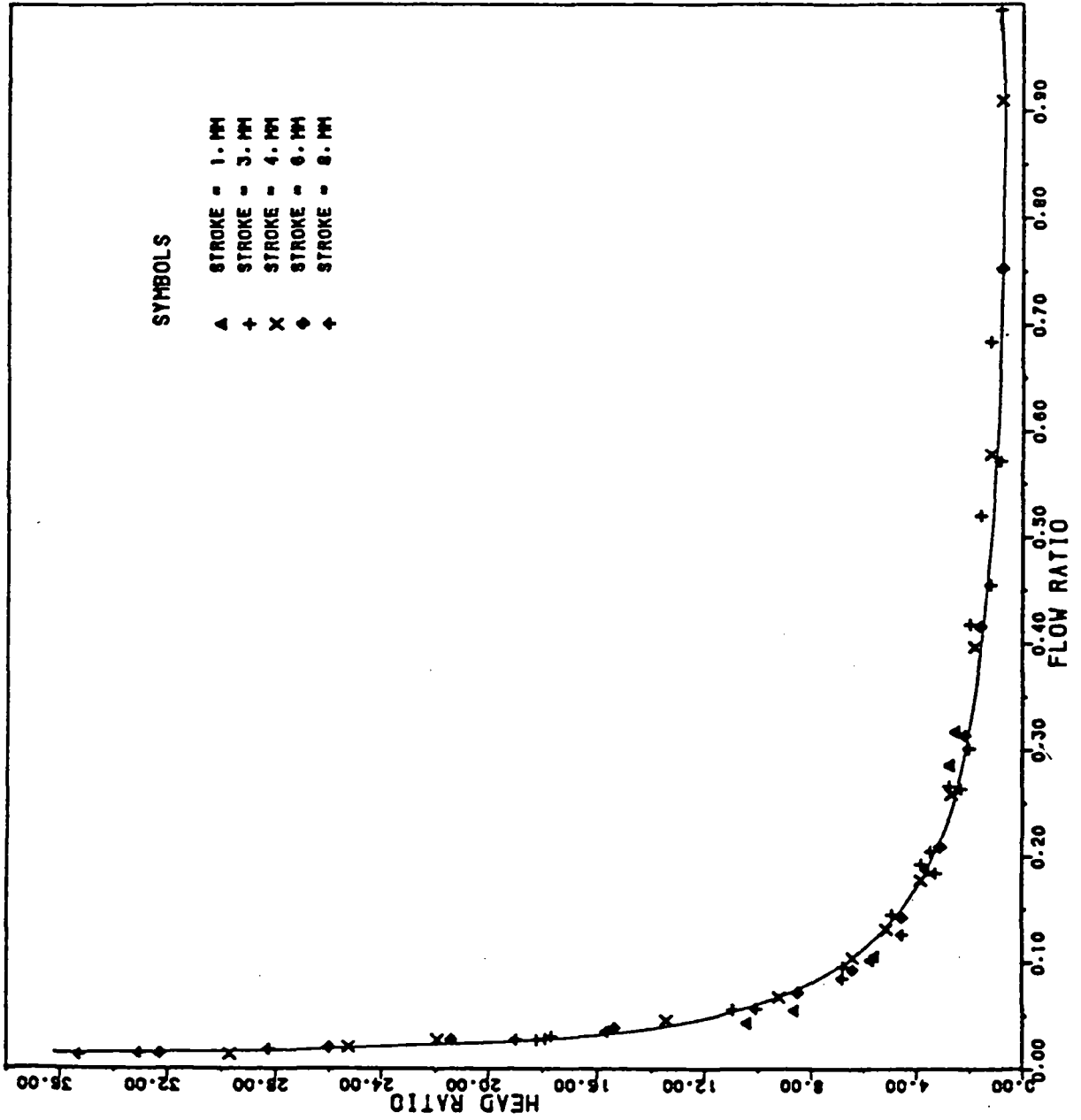

FIG. 7 ITDG (IMPULSE) HYDRANT HEAD RATIO VS FLOW RATIO

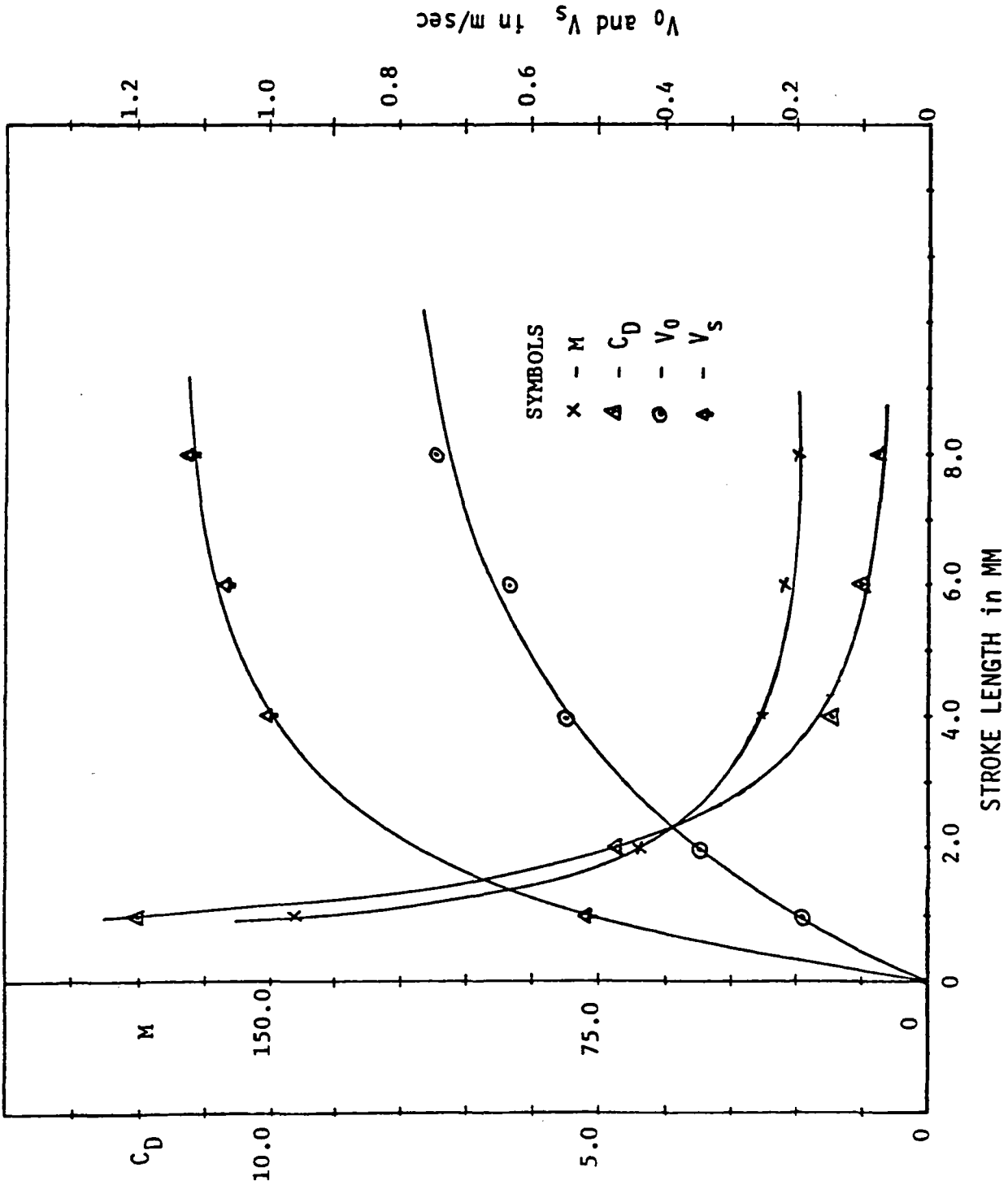

FIG. 8 VARIATION OF  $M$ ,  $C_D$ ,  $V_0$  AND  $V_s$  WITH STROKE LENGTH FOR THE ITDG (WEIGHTED IMPULSE VALVE) HYDRAM

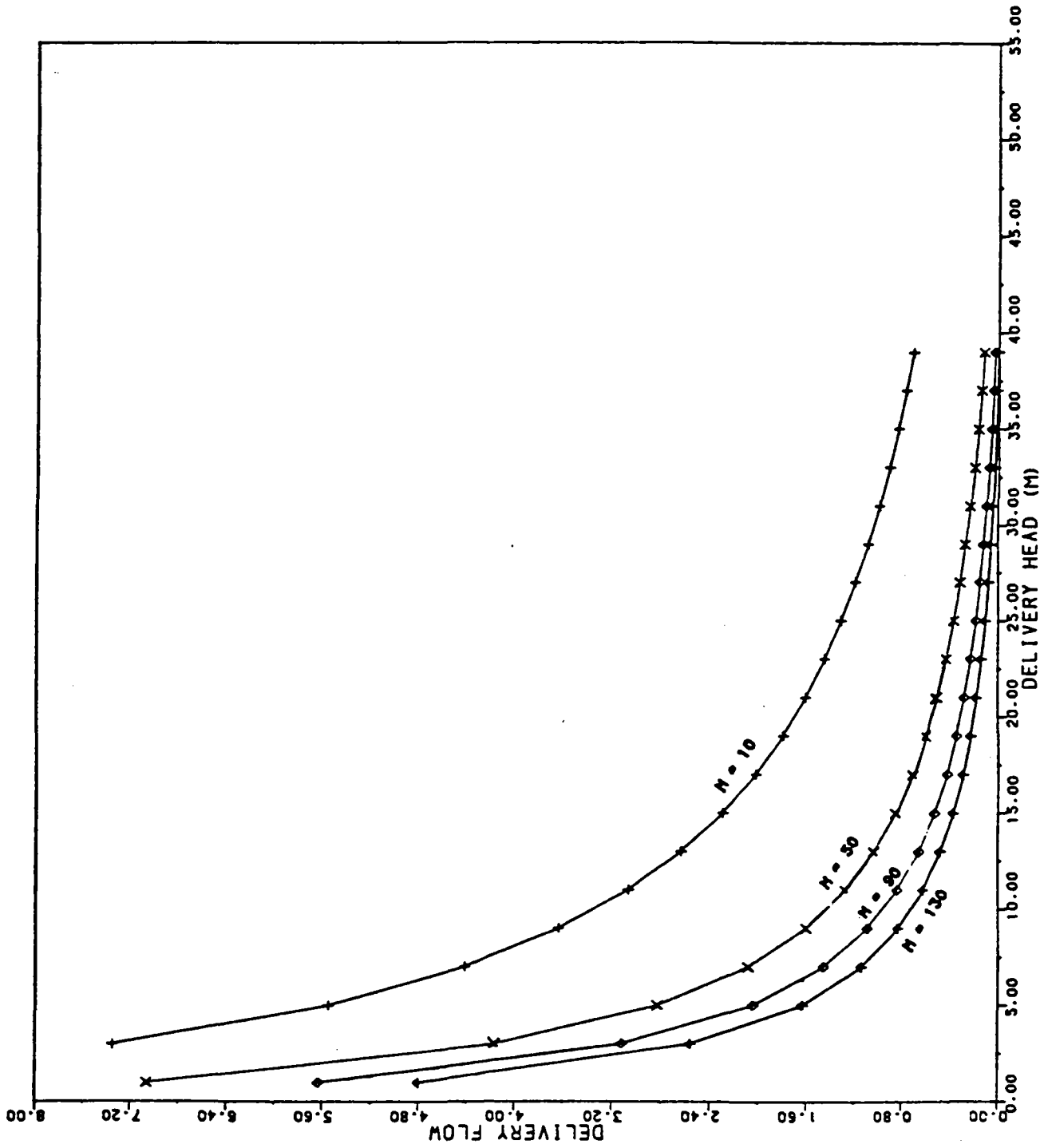

FIG. 9 EFFECT OF THE FRICTIONAL HEAD LOSS OF THE WASTE VALVE ON PUMP CAPACITY

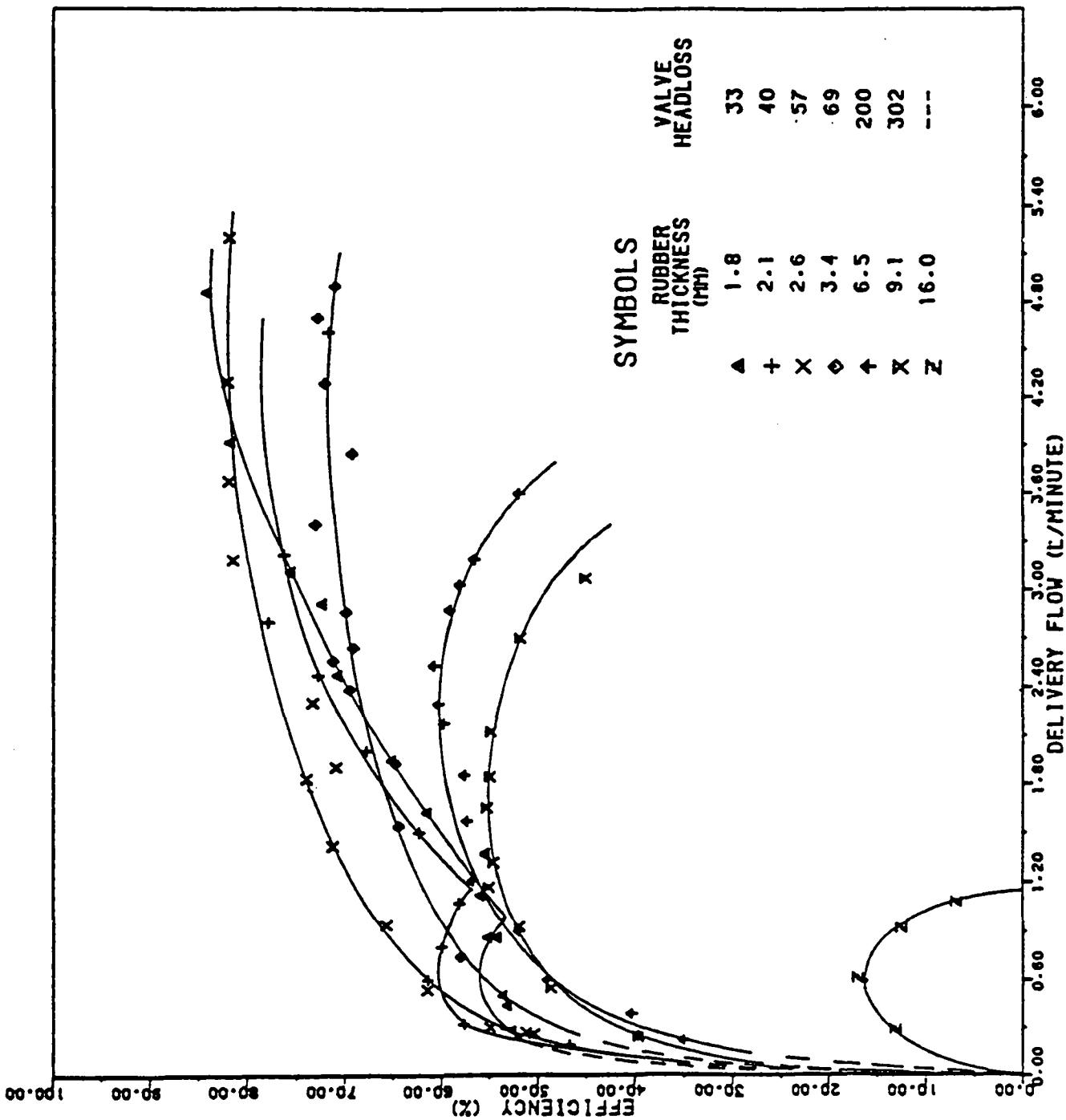

FIG. 10 ITDG (IMPULSE) HYDRAM • EFFECT OF DELIVERY VALVE ON PUMP EFFICIENCY

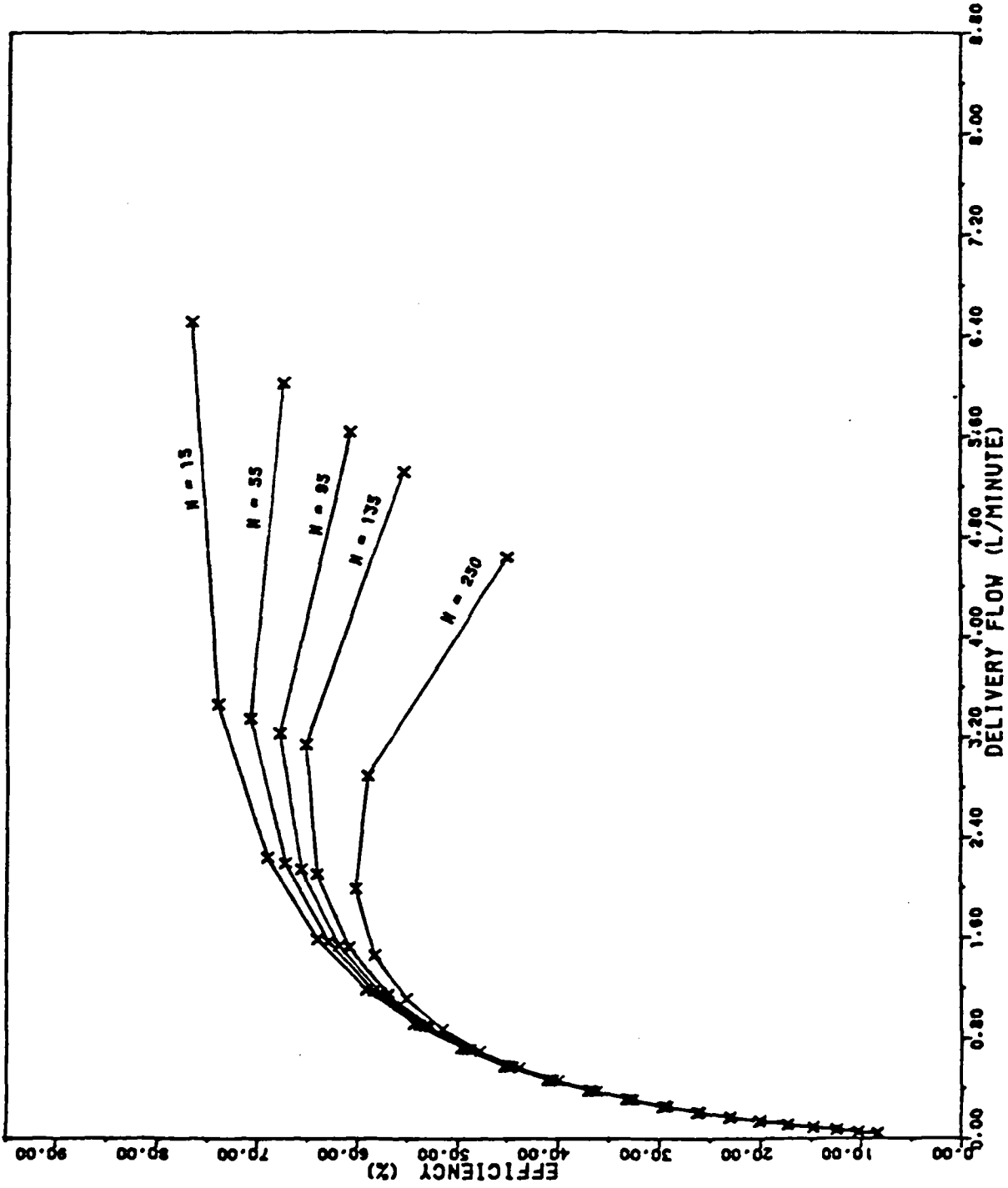

FIG. 11 EFFECT OF FRICTIONAL HEADLOSS OF THE DELIVERY VALVE ON PUMP EFFICIENCY



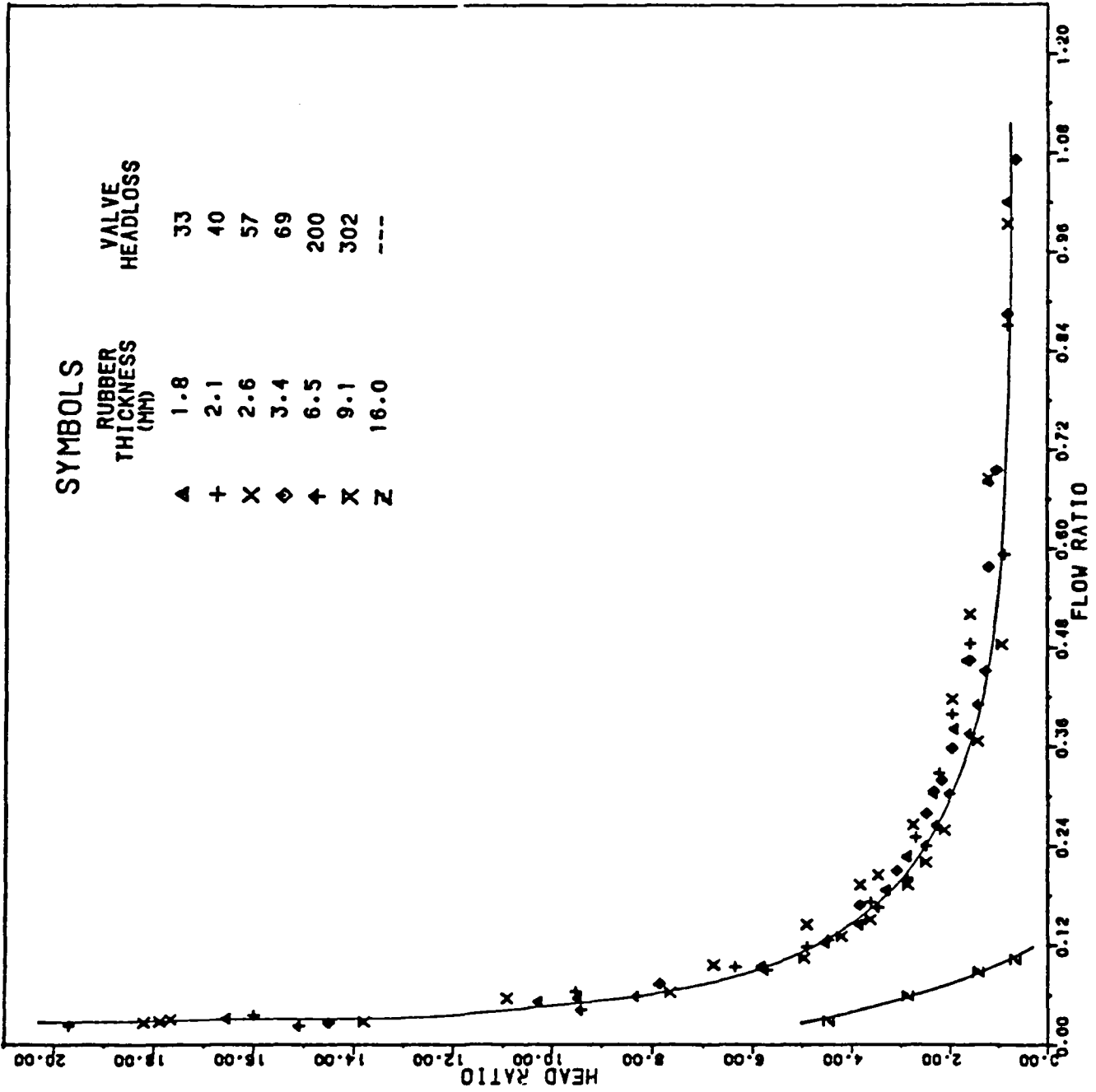

FIG. 12 ITDG (IMPULSE) HYDRUM EFFECT OF DELIVERY VALVE ON PUMP PERFORMANCE

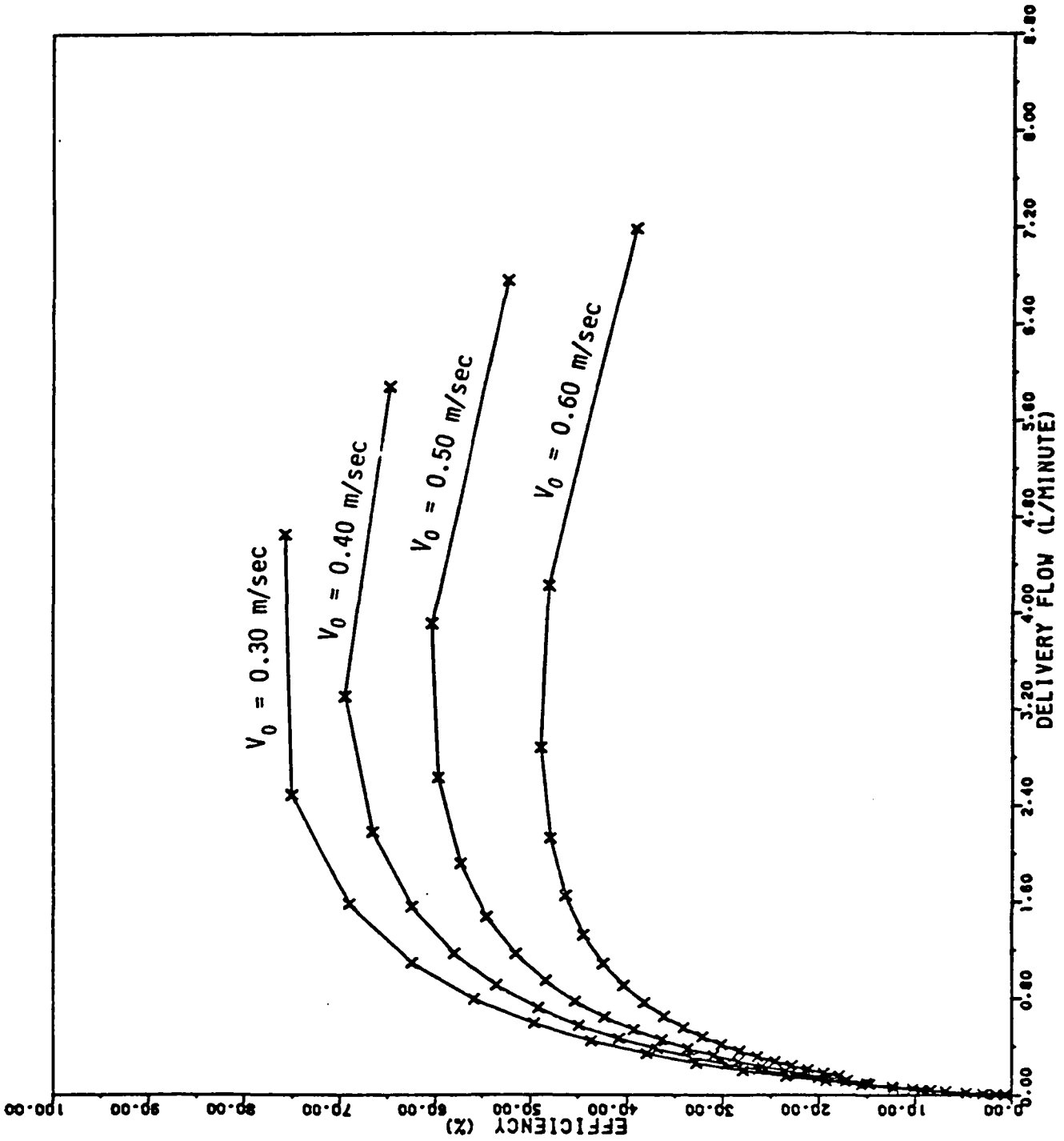

FIG. 13 EFFECT OF  $V_0$  ON PUMP EFFICIENCY

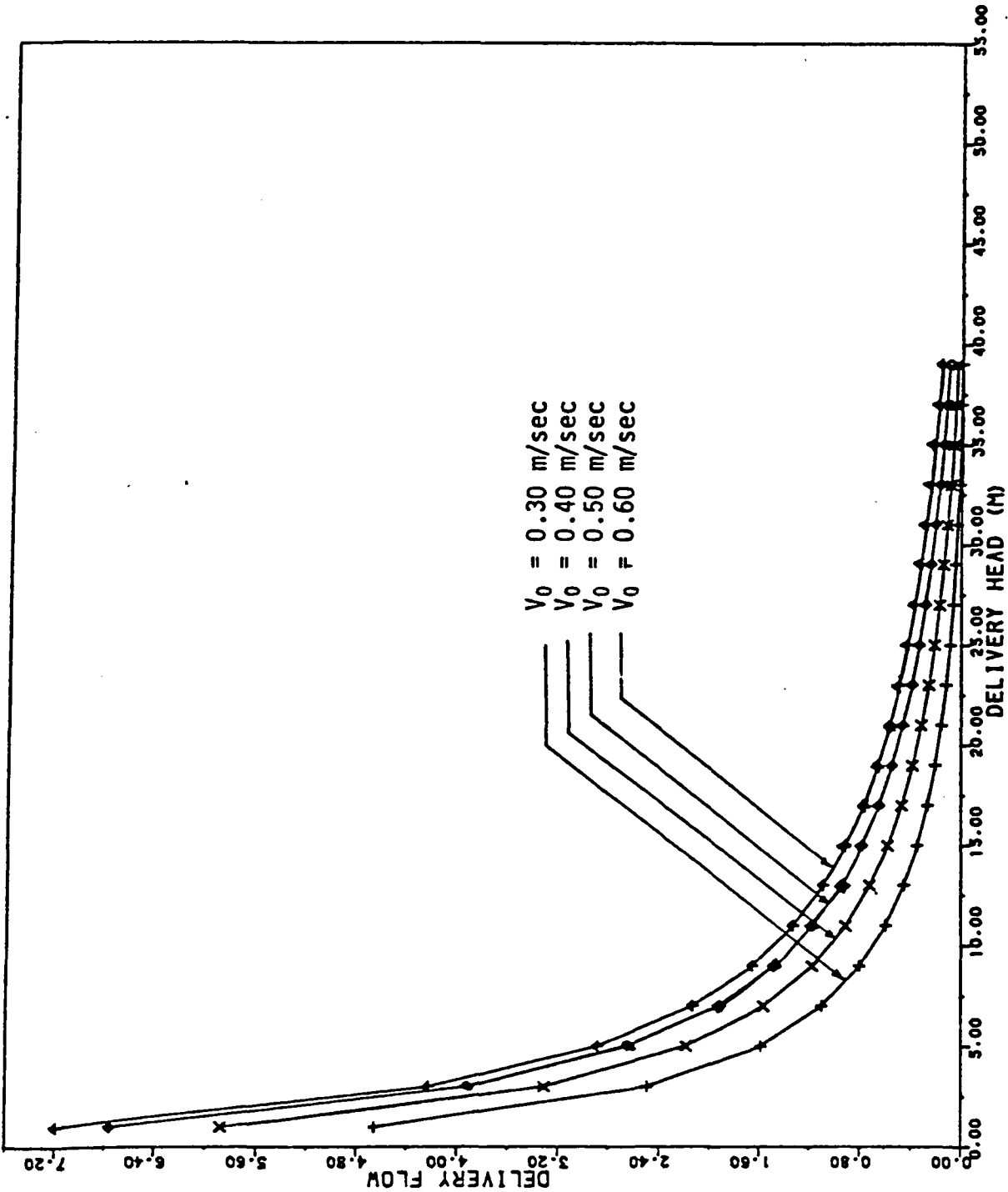

FIG. 14 EFFECT OF  $V_0$  ON DELIVERY FLOW

## REFERENCES

1. Addison, H. A treatise on Applied Hydraulics. London: Chapman and Hall Ltd., 1964.
2. Anderson, E.W. "Hydraulic Rams". Institution of Mechanical Engineers, Proceedings, Vol. 1, 1922. pp 337-335.
3. Bergeron, L. "Beliers Hydrauliques" (Translation). Paris: Dunod, 1928. pp 60-104.
4. Calvert, N.G. "Drive Pipe of a Hydraulic Ram." The Engineer, Vol. 206 No. 5370. London: December, 1985. pp1001.
5. Calvert, N.G. "Hydraulic Ram as a Suction Pump." The Engineer. London: April, 1960.
7. Clark, J.W. "Hydraulic Rams, their Principles and Construction: A Handbook for Practical Men." London: T.T. Batsford, Sept. 1907 (2nd Edition).
8. Cleghorne, W.S.H. "The Hydraulic Ram." South African Journal of Industries. Feb. 1919. pp 135-142.
9. Gibson, A.M. Hydraulics and its Applications. London: (5th Edition) 1961.
10. Hwang, N.H. Fundamentals of Hydraulic Engineering Systems. New Jersey: Prentice-Hall Inc., Eaglewood Cliffs. 1981.
11. Inversin, A.R. "Hydraulic Ram for Tropical Climates." Vita Publication. Vita, Mt. Rainier, Maryland. 1979.
12. Inversin, A.R. "The Construction of a Hydraulic Ram Pump." Papua New Guinea: South Pacific Appropriate Technology Foundation. Feb. 1978.
13. Iversen, H.W. "An Analysis of the Hydraulic Ram." Journal of Fluids Engineering, ASME, No. 75-FE-F, Transactions. New York: ASME, June 1975. pp 191-196.
14. Kindel, E.W. A Hydraulic Ram for Village Use. A Vita Publication. Mt. Rainier, Maryland: Vita Inc. 1970.

15. Krol, J. "The Automatic Hydraulic Ram." Proceedings of the Institution of Mechanical Engineers, Vol. 165. 1952. pp 53-65.
16. Krol, J. "The Automatic Hydraulic Rams: Its Theory and Design." ASME Proceedings. ASME, January 1977.
17. Kaufman, A.W. "Hydraulic Ram Forces Water to Pump Itself." Popular Science, October 1948. pp 231-133.
18. Madeley, John. "Ram Pumps End Kenyan Woman's Water Trek." World Water, October 1981.
19. Massey, B.S. Mechanics of Fluids, 13(3rd Edition). London: Van Nostrand Reinhold Co., 1968.
20. Lansford, W.M. and Dugan, W.G. "An Analytical and Experimental Study of the Hydraulic Ram." Bulletin No. 326, Vol. 38. University of Illinois Engineering Experimental Station: 1941.
21. Mead, D.W. "The Hydraulic Ram." Hydraulic Machinery. New York: 1933. pp 358-383.
22. Mead, D.W. "The Hydraulic Ram for Use in Public Waterworks Systems". Illinois Society of Engineers and Surveyors, 11th Annual Report. Illinois: 1896.
23. Mead, D.W. "A Large Hydraulic Ram". The Engineering Record, Vol. 44 No 8. New York: August 1901.
24. Molyneux, F. "The Hydraulic Ram Pump for Rural Water Supply." Journal of Fluid Handling, October 1960. pp 274-276.
25. Gosline, J.E. and O'Brien, M.P. "The Hydraulic Ram". University of California Publications in Engineering, Vol. 3, No. 1. University of California Press: Berkeley, California, 1933. pp 1-58.
26. Parker, P.M. "The Hydraulic Ram". The Control of Water as Applied to Irrigation, Power and Town Water Supply Purposes. London: Routledge, G & Sons Ltd., 1932. pp 843-853.
27. Parmakian, John. Waterhammer Analysis. New York: Dover Publications, Inc. 2nd Edition. 1963.

28. Protzen, E.P. "A proposal for Simple Performance Prediction of the Hydraulic Ram." (Unpublished Research Results), Institute for Production Innovation. Dar Es Salaam, University of Dar Es Salaam. June 1980.
29. Richards, J. "Hydraulic Rams." New York, Journal of the Association of Engineering Societies, Vol. 10. January 1898. pp 27-50.
30. Rife Hydraulic Engine Mfg. Co. Rife Hydraulic Ram (Owner's guide to installation, operation, maintenance and service). New Jersey, 1969.
31. Rife Hydraulic Engine Mfg. Co. Manual of Information: Rife Hydraulic Water Rams, New Jersey: 1981.
32. Schiller, E.J. "Development of a Locally Made Hydraulic Ram Pump." ENERGEX '82 Conference Proceedings, Solar Energy Society of Canada. August 1982. pp 503-506.
33. Schiller, E.J. "Renewable Energy Pumping from Rivers and Streams." Water Supply and Sanitation for Developing Countries. Michigan: Ann Arbor Science Publishers, 1982. pp 53-64.
34. Silver, Mitchell. Use of Hydraulic Rams in Nepal. A guide to Manufacturing and Installation. Kathumandu, Nepal: UNICEF, September 1977.
35. Stevens-Guille, P.D. "An Innovation in Water Ram Pumps for Domestic and Irrigation Use." London, Appropriate Technology, Vol. 5 No. 1, May 1970.
36. Stevens-Guille, P.D. "How to Make and Install a Low-cost Water Ram Pump for Domestic and Irrigation Use." Cape Town: Department of Mechanical Engineering, University of Cape Town, August 1977.
37. Streeter, V.L. and Wyle, E.B. Hydraulic Transients. N.Y.: McGraw Hill Book Company, 1967.
38. Watt, S.B. A Manual on the Hydraulic Ram for Pumping Water. London, Intermediate Technology. London, Intermediate Technology Ltd. 1975.
39. Weisbach, J. and Herrmann, G. "The Hydraulic Ram." The Mechanics of Pumping Machinery. London: McMillan, 1897. pp 255-265.

## HYDRAULIC RAMS AS POTENTIAL PUMPING UNITS FOR RURAL WATER SUPPLY SCHEMES IN TANZANIA

T.S.A. Mbwette and E. Th. P. Protzen

### SUMMARY

This paper presents one of the many efforts made by the Faculty of Engineering and the Institute of Production Innovation of the UDSM (University of Dar Es Salaam) towards the realization of the aims of the International Water Supply and Sanitation Decade. Special reference is made to the use of hydraulic rams along with some simple water treatment methods. Beyond the account of theoretical and practical work done to date in the field of water supply, the following recommendations are made in order to enable water engineers to utilize the hydraulic ram in their future design work:

- 1) that an external sponsor be identified to help evaluate the presented theoretical model to enable an evaluation of present designs and, where necessary, make modifications.
- 2) that tests be made on a typical design. The work can easily be done locally since hydraulic rams are already produced in Tanzania.
- 3) that an external sponsor help produce performance charts for the Tanzanian design.
- 4) that the new design be marketed.

### INTRODUCTION

For several years now members of staff of the Faculty of Engineering and the Institute of Production Innovation at the University of Dar es Salaam have been working on simple water treatment and pumping systems. This paper gives a brief summary of detailed investigations carried out in this field. Extensive documentation of these activities can be found in references (2), (4) and (7). Tanzania has known the hydraulic ram for at least five decades, but most of the many pumps initially installed have now disappeared although their simplicity of operation, their relatively negligible maintenance requirement and especially the fact that these pumps draw their motive power from their water source are technical factors which highly favour their application in remote rural areas.

The authors both remember very well how fascinated they were as children by the numerous thumping water pumps which could be found along many streams and brooks. It seems a joke that people should now be working on the reactivation of hydraulic ram technology.

#### **A SHORT HISTORY OF THE HYDRAULIC RAM**

Invention of the hydraulic ram is credited to an Englishman, Mr. John Whitehurst, whose first machine was installed in a brewery in 1773. The drive valve - tap - was operated manually by a child. (8) In 1779 Joseph Michael de Montgolfier developed the self-acting hydraulic ram. On his machine it was found that over a period of time the air in the air vessel was gradually absorbed by the water passing through it and the working of the ram was affected. This problem was solved by the younger brother of Montgolfier who added the snifter valve to keep the vessel supplied with air.

Since then, quite a number of types of hydraulic ram pumps have been put on the world market - some have disappeared, others are still being manufactured. Quite a lot of work has been invested in the theoretical approach (5), (6), (7). It seems though that to date, the manufacturers and the theoreticians have seldom got down to working together in an attempt to optimize the performance and use of the hydraulic ram in water supply systems.

#### **APPLICABILITY OF HYDRAULIC RAMS IN WATER SUPPLY SCHEMES**

Regarding the possibility of introducing hydraulic rams into drinking (or small scale irrigation) water supply schemes: as long as topographical and hydrological requirements are satisfied, they can be used to pump either raw water from a source into the treatment plant or as a single stage pump from a pretreatment unit into the main treatment facilities. However, it is not very common to use hydraulic rams for pumping treated water to storage tanks because the conventional design would involve wastage of a big proportion of the treated water which would have to pass through the drive valve during the pumping cycles. It would only be possible if the raw water does not need any treatment besides disinfection before distribution. In this case, disinfection can be conveniently done in the storage tank if no contact reservoir is provided. (It must be noted here that rams are available that can utilize untreated water to pump clean water.) In essence, this means that hydraulic rams can be very suitably applied in schemes where the source is lower than the end user if the topography allows water to be supplied by gravity after single stage pumping through the treatment plant or storage tank. A cross section of such a system is shown in Fig. 1 below.



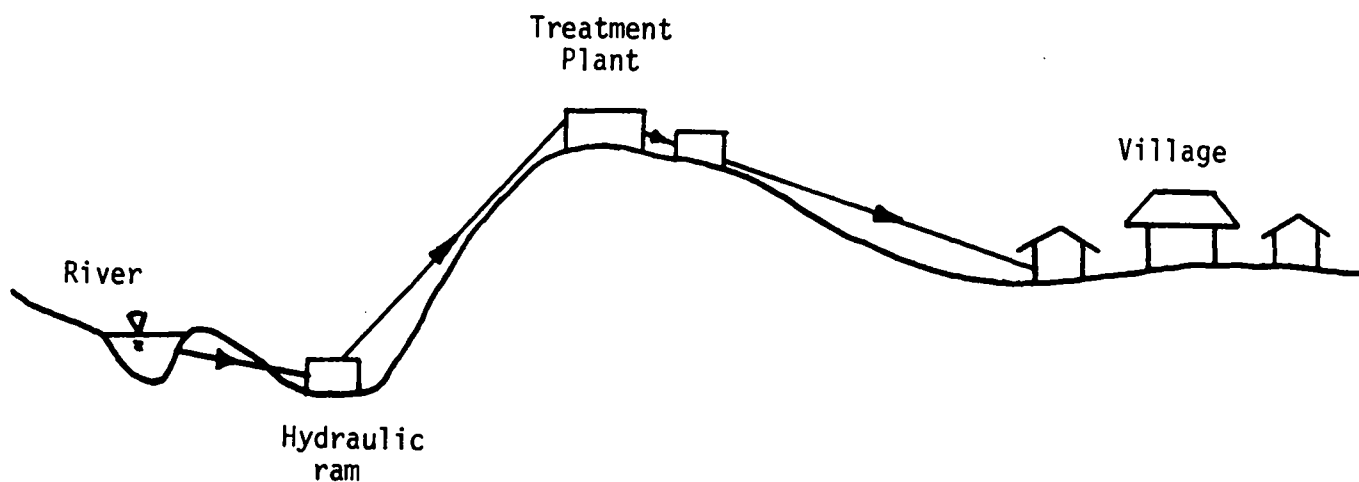
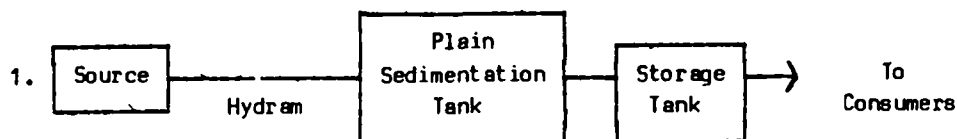
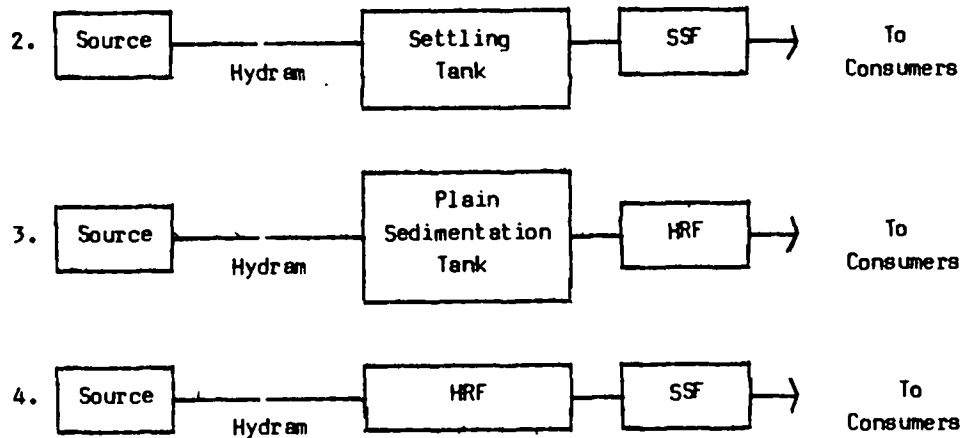

Fig. 1 Schematic cross section of a village water supply scheme with a hydraulic ram pump.

#### HYDRAULIC RAMS IN SIMPLE TREATMENT PLANTS

In cases where raw water has to be treated or improved to acceptable levels before distribution to consumers, the use of hydraulic rams along with some simple treatment or pretreatment methods can ensure the reliability and appropriateness of the whole scheme in remote rural areas. The flow charts Nos. 1 - 4 below give some for the options of simple treatment systems for raw water pumped by hydraulic rams.





Note: SSF = Slow Sand Filter  
HRF = Horizontal Roughing Filter

Flow charts 1 through 3 are suitable for raw waters with fairly poor physical quality and rather low bacterial pollution levels (4). Flow chart number 4 is suitable even for cases of water with relatively poor physical quality and high bacterial pollution as long as the filtration rates used are limited to acceptable levels.(1) (2) It must however be noted that, in all the four cases considered here, it is assumed that the raw water has very few or no foreign chemical pollutants since the effect of industrial activities on water pollution is not yet very pronounced in rural areas of most developing countries.

#### RESEARCH IN PRETREATMENT FOR SLOW SAND FILTERS IN TANZANIA

Since 1979 and after getting reports of poor performances of most of the Slow Sand Filters (SSF) built in different parts of Tanzania, the Department of Civil Engineering of the UDSM has been conducting extensive research into the use of Horizontal Flow Roughing Filters (HRF) as a pretreatment of water entering SSFs. To this end, the Civil Engineering Department first established that the cause of the poor operating condition of the SSF was the extended direct feeding into the SSF of raw waters of unacceptable quality (i.e. with turbidity of more than 50 NTU or suspended solid concentration of more than 10mg/l) which resulted in very fast clogging of the filter beds. Thereafter, laboratory and field tests were carried out in order to establish the best and simplest biophysical pretreatment methods. HRF proved to be superior in comparison with the other three methods investigated(3) (namely, plain sedimentation, plain sedimentation aided with lamella settlers and vertical roughing filters).

In 1981, a pilot plant of village scale was constructed in Iringa in order to carry out longterm field tests with the HRF-SSF systems there (see Fig.2). The research work has proved the technical suitability of this method in practise<sup>(4)</sup> and at the moment, the Civil Engineering Department of UDSM, in collaboration with the Ministry of Water and Energy, Danish International Development Aid (DANIDA), the Norwegian Agency for International Development (NORAD) and the International Reference Centre for Wastes Disposal (IRCWD), is involved in the last stage of field investigations which involves constructing and monitoring the operation of a number of village demonstration schemes in the regions of Mbeya, Rukwa and Iringa in order to gain more experience with this technique of water treatment. In addition, this programme will enable the assessment of the technique's acceptability and suitability and evaluate community participation aspects. NORAD has already started construction of one such scheme with hydraulic ram pumps, HRF and SSF in the village of Kasote in Rukwa region. More information about the research work in HRF - SSF systems carried out at UDSM can be obtained from references (2) and (3).

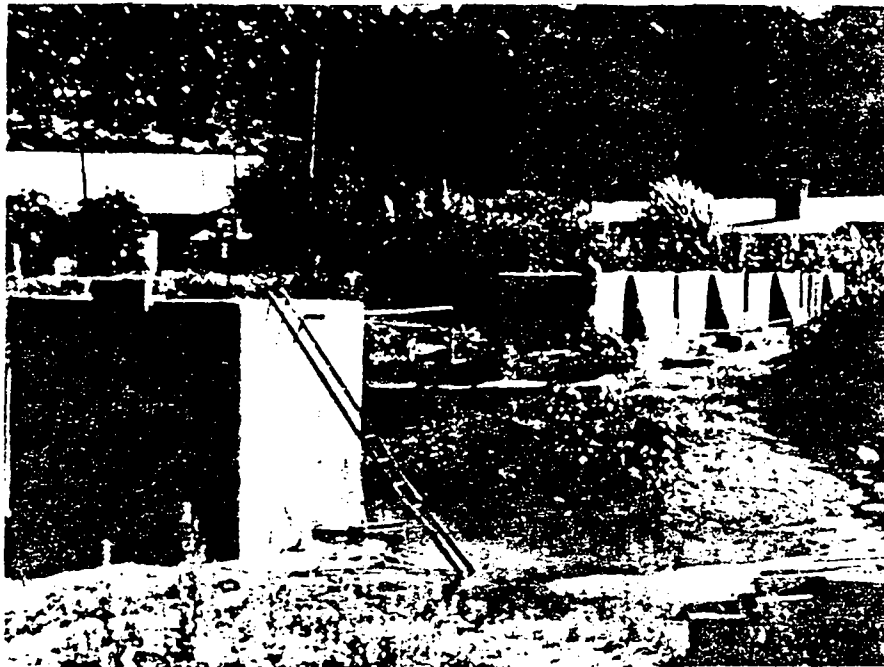

Fig.2. The pilot plant constructed at Iringa

## OPTIMAL HYDRAULIC RAM PERFORMANCE

It is our idea that for every size of hydraulic rams, suppliers should have at hand a set of charts that will help engineers to fully utilize the possibilities of the pump. This is common practice for any other type of pumps (centrifugal pumps, plunger pumps). Only with such charts in hand can water engineers set out to design good water supply systems with hydraulic rams. To this end, since 1976 the Department of Mechanical Engineering of the Faculty of Engineering and later the Institute of Production Innovation both at the USDM have been analysing theoretical approaches to the prediction of pump operation. We have been following the activities of Jandu Plumbers in Arusha who are competent builders of hydraulic rams of the Blake type. We are aware of the fact that there is still a lot of scope for improvement and that it is possible to develop a new generation with yet better and truly predictable performance, possibly competitive enough for export to neighbouring countries.

## EXTERNAL INPUTS REQUIRED FOR A CONTINUATION OF STARTED WORK AT THE UNIVERSITY OF DAR ES SALAAM

Based mainly on two published papers<sup>(5)</sup><sup>(6)</sup> which in our view give sufficient theoretical background to the design engineer for a good optimization of dimensions, performance and end use, we formulated a theoretical model in 1980 <sup>(7)</sup> that to date has required only limited refinement. An evaluation of the model requires the use of quite a powerful computer with a plotter, both of which we do not have.

It is very easy to build a working hydraulic ram, but an optimum design with predictable performance can only be made once the full evaluation of a theoretical model has taken place.

## THE THEORETICAL MODEL

For the following development we assume that the reader is familiar with basic hydraulic ram theory. The symbols used are defined at the end of this paper.

The entire period of a complete cycle of events in hydraulic ram operation is composed of:

- a) the period of acceleration of the drive flow from zero velocity to the velocity at which closure of the drive valve takes place;

- b) the period of deceleration of the pumped flow from the time of simultaneous opening of the discharge valve with closure of the drive valve until the pumped flow reaches zero velocity;
- c) the period of deceleration of the reverse flow from the time of simultaneous closure of the discharge valve with opening of the drive valve until the flow reaches zero velocity to initiate another period a).

$$-\frac{dp}{g\rho} - dz - \frac{fV^2dL}{2gD} = \frac{dV}{dt} \frac{dL}{g} \quad (0)$$

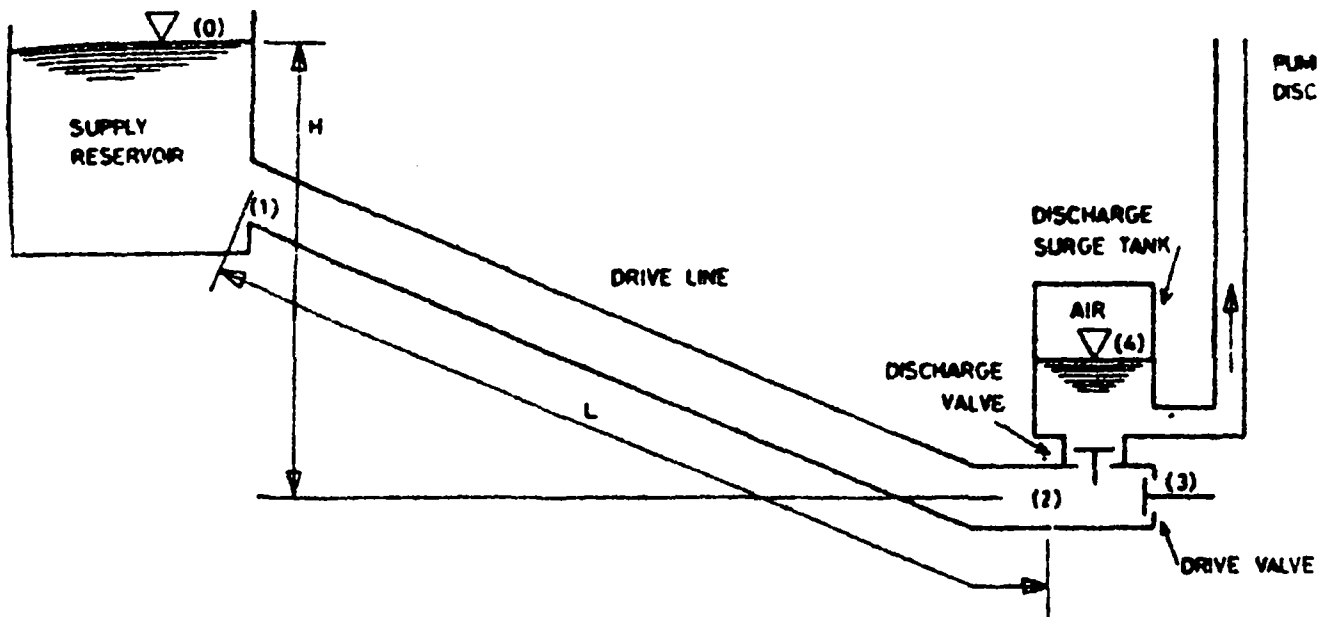

Fig. 3. The Hydraulic Ram Control Positions

Formulating this equation specifically for the above-mentioned periods in connection with Fig. 3 and taking volumetric losses into account one arrives at:

I) the volume of water actually pumped during one pumping interval

$$Q_p = \frac{LA}{N_p} \ln \left( \frac{N \phi}{K_p \frac{h}{H}} + 1 \right) - Q_1 \quad (I)$$

with  $\phi = F/(\rho gHA)$  characterizing the load on the drive valve.

If during the operation of a hydraulic ram, the delivery head,  $h$ , is increased gradually, there comes a point at which the machine will still operate but not pump. Under the assumptions of perfectly sealing valves this point is characterized by the equation

$$\frac{LA}{N_p} \ln \left( \frac{N \phi}{K_p \frac{h}{H}} + 1 \right) = Q_1$$

II) the volume of water actually wasted during one drive interval is:

$$Q_d = \frac{LA}{N_d} \ln \left( \frac{1}{\frac{1-N_r}{K_d}} \right) + Q_1 - \frac{LA}{N_r} \ln \left( \frac{N_r \left( \frac{h}{H} \right)^2 \rho gH}{2B} + 1 \right) \quad (II)$$

Especially with a low drive head,  $H$ , a hydraulic ram will not operate when a certain delivery head,  $h$ , is exceeded. This phenomenon occurs when the volumetric loss,  $Q_1$ , is greater than or equal to the reverse flow volume per cycle.

$$Q_1 \gg \frac{LA}{N_r} \ln \left( \frac{N_r}{2B} \left( \frac{h}{H} \right)^2 \rho g H + 1 \right)$$

III) the time required for the full sequence of events is:

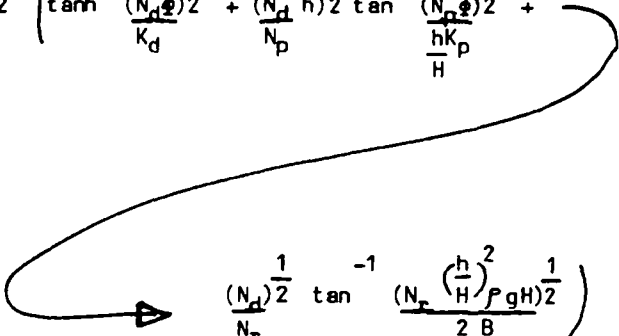
$$t = \frac{(2L^2)}{gHN_d} \frac{1}{2} \left( \tanh^{-1} \frac{1}{\frac{N_d}{K_d}} \frac{1}{2} + \frac{H}{N_p} \frac{1}{2} \tan^{-1} \frac{1}{\frac{h k_p}{H}} \frac{1}{2} + \right.$$

$$\left. \frac{1}{N_r} \frac{1}{2} \tan^{-1} \frac{1}{\frac{N_r}{2B} \left( \frac{h}{H} \right)^2 \rho g H} \frac{1}{2} \right) \quad (III)$$

With the aid of values from equations (I) and (II) the efficiency of the system from position (0) to position (4) Fig. 3 is calculated by:

$$\eta = \frac{Q_p}{Q_d} \frac{h}{H} \quad (IV)$$

Furthermore a quality criterion is defined that allows quick comparisons to be made between different hydraulic rams operating on the same drive line bore. High efficiency alone does not characterize the good machine; in addition to this, the delivery flow must be as high as possible, the drive line dimensions and cycle frequency as low as possible.

$$C = \eta \frac{Q_p}{L.A} \quad (V)$$

#### FURTHER DEVELOPMENTS

With the above theoretical model at hand we would see a further development of the started work to consist of five phases

Phase I: An evaluation of the equations for some standard size hydraulic rams with variations of topographic and geometric data.

Phase II: A judgement of the present Tanzanian hydraulic rams with the resulting evaluation followed, if necessary, by a new design.

Phase III: The determination of head loss coefficients of valves.

Phase IV: An evaluation of the theoretical model for the full range of Tanzanian hydraulic rams be it of a new design or the already existing one.

Phase V: Either continued manufacture of the present Jandu model or manufacture of the new design, marketed with performance charts.



As already stated above, we are not in the position to do the evaluation work in Tanzania. We are fully aware of the fact that this involves pure donkey work and we would gladly do it if we had the right computer at our disposal. How rewarding the expected results would be, is demonstrated in Fig. 4 to 9 which compare the values of  $\eta$ ,  $C$ ,  $\xi$ ,  $\eta$ ,  $\varphi_p$ ,  $\varphi_t$  for two hydraulic rams on a 3-inch drive line and a 3-inch delivery valve. One ram has a 4 1/4 inch the other an 8 1/2 inch drive valve. Striking is the short drive line on the latter and the substantially increased performance for points on the max-2% line. The figures are a result of a tedious effort to programme the theoretical model on an electronic calculator and finally to plot the results manually. Since the performance of a hydraulic ram depends on the Reynolds number the evaluation for Phase I would have to be undertaken for say a 3/4 inch and an 8 inch drive pipe by:

- varying  $H$  from  $H = 1 \text{ m}$  to  $H = 20 \text{ m}$

- varying  $A_p/A$  from  $A_p/A = 1$  to  $A_p/A = 1$

- varying  $A_d/A$  from  $A_d/A = 1$  to  $A_d/A = 20$

and plotting  $\eta(L \text{ h/H})$ ,  $C(L \text{ h/H})$ ,  $\xi(L \text{ h/H})$ ,  $\eta(L \text{ h/H})$ ,  $\varphi_p(L \text{ h/H})$ ,  $\varphi_t(L \text{ h/H})$

- with  $L$  from  $L = H$  to  $L = 1000\text{m}$

- with  $\frac{h}{H}$  from  $\frac{h}{H} = 1$  to  $\frac{h}{H} = 100$

- with  $\xi$  varying at any point ( $L \text{ h/H}$ ) to maximize efficiency.

The judgement in Phase II would then allow the same evaluation to take place in Phase IV with selected values of  $A_p/A$ ,  $A_d/A$ . Whereas, in Phase I any sensible value of valve loss coefficients would serve the purpose, true measured values from Phase III would be inserted for Phase IV.

## CONCLUSIONS

1. From the point of view of water supply design, the engineers are only awaiting a hydraulic ram with established performance data so as to confidently incorporate it in their schemes.
2. The theoretical model for hydram optimization and performance prediction is ready for evaluation. This evaluation cannot be done in Tanzania for lack of sufficient computer capacity.
3. Given a sponsor for the evaluation design work on a new generation of rams with true performance data, the work can be undertaken and designs placed at the disposal of water engineers.

REFERENCES:

- 1) "Slow Sand Filtration for Community Water Supply in Developing Countries", A Design and Construction Manual. Technical paper 11, (1978). IRC/WHO, The Hague - The Netherlands.
- 2) WEGELIN, M. and MBWETTE, T.S.A. (July 1982). "Slow Sand Filter Research Project Report 3". Research report CMS 82.3, University of Dar es Salaam - Tanzania.
- 3) WEGELIN, M. (July 1980). "Slow Sand Filter Research Project Report 2". Research Report CMS 80.2, University of Dar es Salaam - Tanzania.
- 4) MBWETTE, T.S.A. (October 1983). "Horizontal Flow Roughing Filters for Rural Water Treatment in Tanzania", M.Sc. Thesis, University of Dar es Salaam - Tanzania.
- 5) IVERSEN, H.W. (June 1975). "An Analysis of the Hydraulic Ram", Journal of Fluids Engineering (Transact of the ASME), pp 191 - 196.
- 6) KROLL, J. (1951). "The Automatic Hydraulic Ram", Institution of Mechanical Engineering Proceedings, Vol. 165, No. 64, pp 53 - 73.
- 7) PROTZEN, E.Th.P. "A Proposal for Simple Performance Prediction of the Hydraulic Ram" Internal Technical Report Available from IPI, USDM.
- 8) STARMER, C. (MARCH 1981). "Blake's Hydram or The Rise and Fall of the Hydraulic Ram, CME, pp 19 - 21.

**NOMENCLATURE**

- A - Cross-section area of flow in drive pipe
- $A_p$  - Cross-section area of delivery valve
- $A_d$  - Cross-section area of drive valve
- B - Bulk Modulus of Water
- C - Quality Criterion
- D - Diameter
- f - Friction factor
- F - Load on drive valve
- g - Gravitational acceleration
- h - Delivery head measured from water level in supply reservoir
- H - Drive head
- $K_p$  - Head loss coefficient of discharge valve
- $K_d$  - Head loss coefficient drive valve
- L - Pipe length, drive pipe length
- $N_p$  - Combined pump flow head loss factor of system
- $N_d$  - Combined delivery flow head loss factor system
- $N_r$  - Combined reverse flow head loss factor system
- p - Pressure
- $Q_p$  - Pumped volume per cycle
- $Q_d$  - Wasted volume per cycle
- $Q_1$  - Lost volume below discharge valve
- $Q_t$  - Total volume per cycle
- t - Time
- V - Average velocity
- $V_p$  - Pumped volume flowrate
- $V_t$  - Total volume flowrate
- $\phi$  - Force coefficient
- $\rho$  - Density of Water
- $\eta$  - Efficiency
- $\nu$  - Cycle frequency

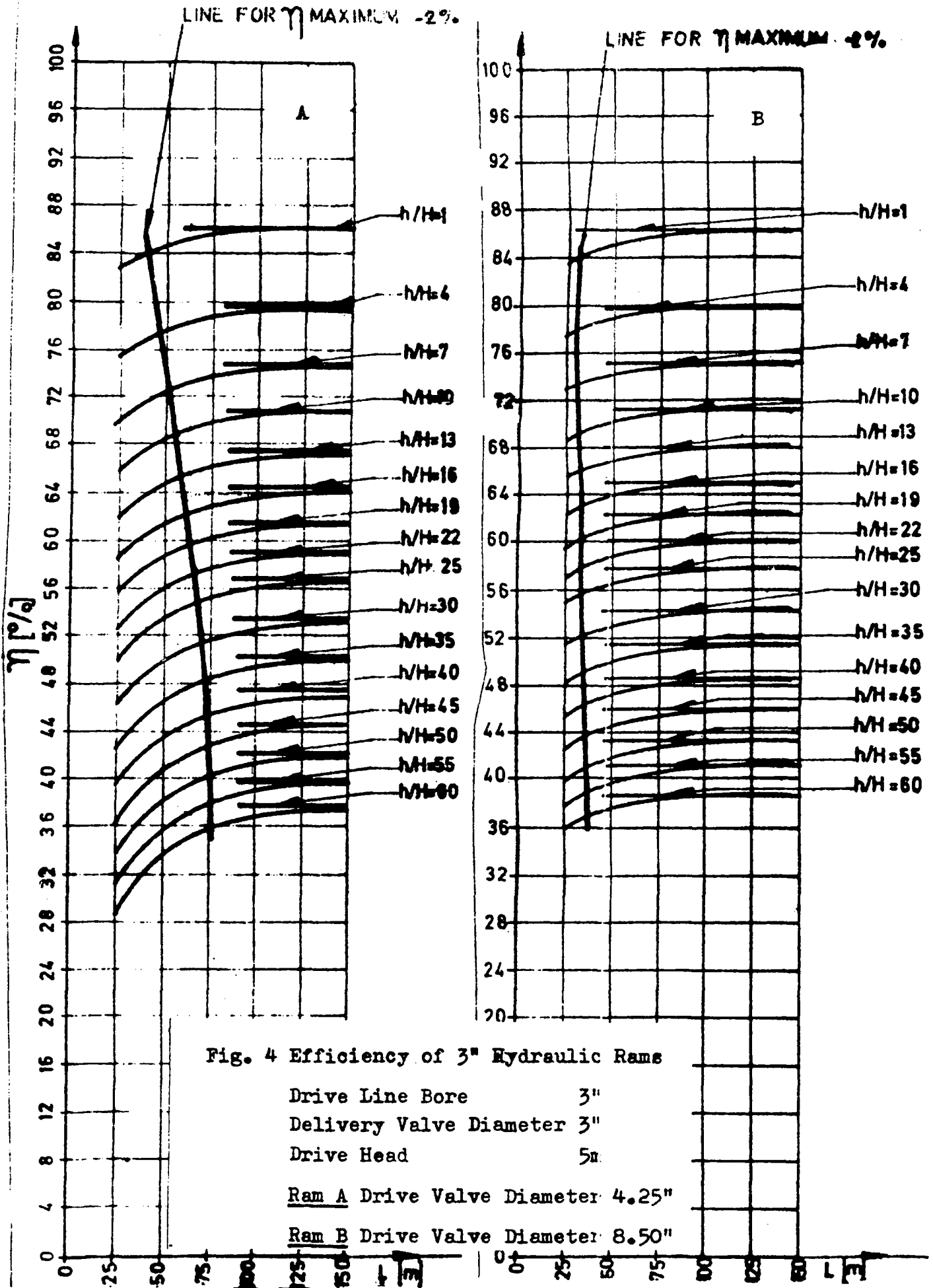

A

B

Fig. 5 Quality Criterion of 3" Hydraulic Rams

Drive Line Bore 3"

Delivery Valve Diameter 3"

Drive Head 5m

Ram A Drive Valve Diameter 4.25"

Ram B Drive Valve Diameter 8.50"

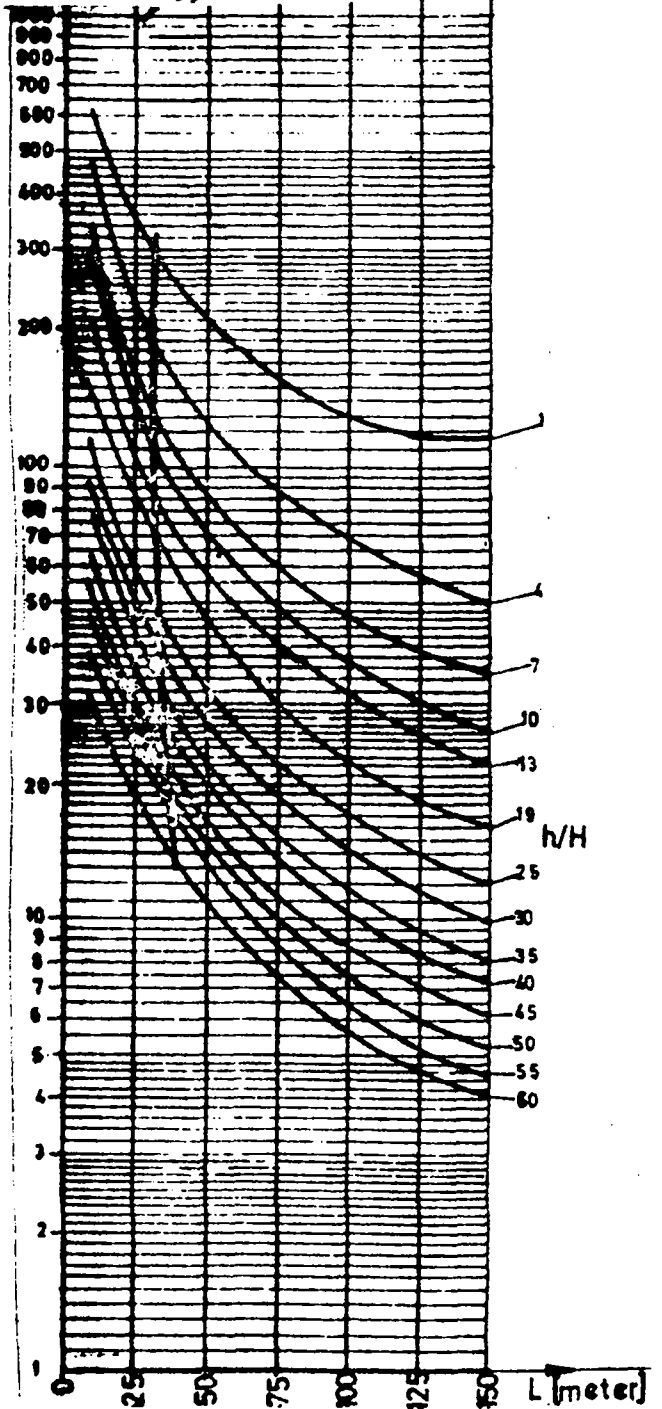
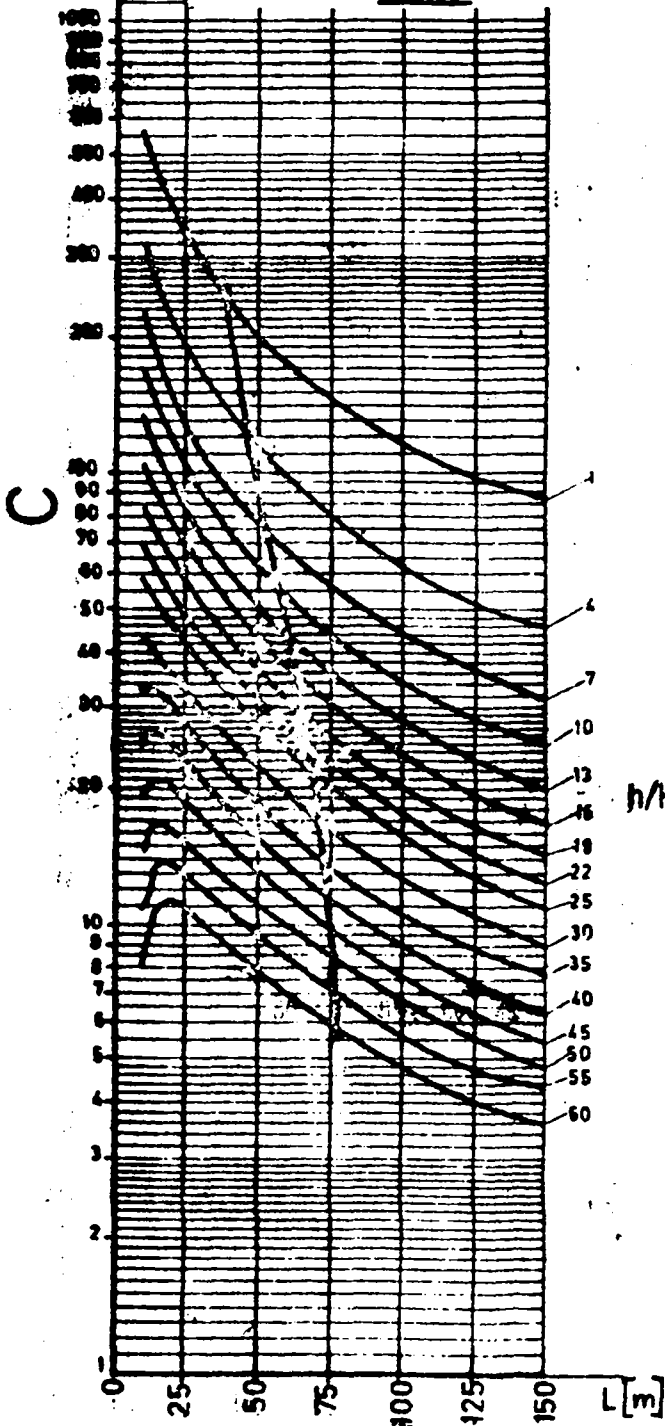

Fig. 6 Load Coefficient of 3" Hydraulic Rams

Drive Line Bore 3"

Delivery Valve Diameter 3"

Drive Head 5m

Ram A Drive Valve Diameter 4.25"

Ram B Drive Valve Diameter 8.50"

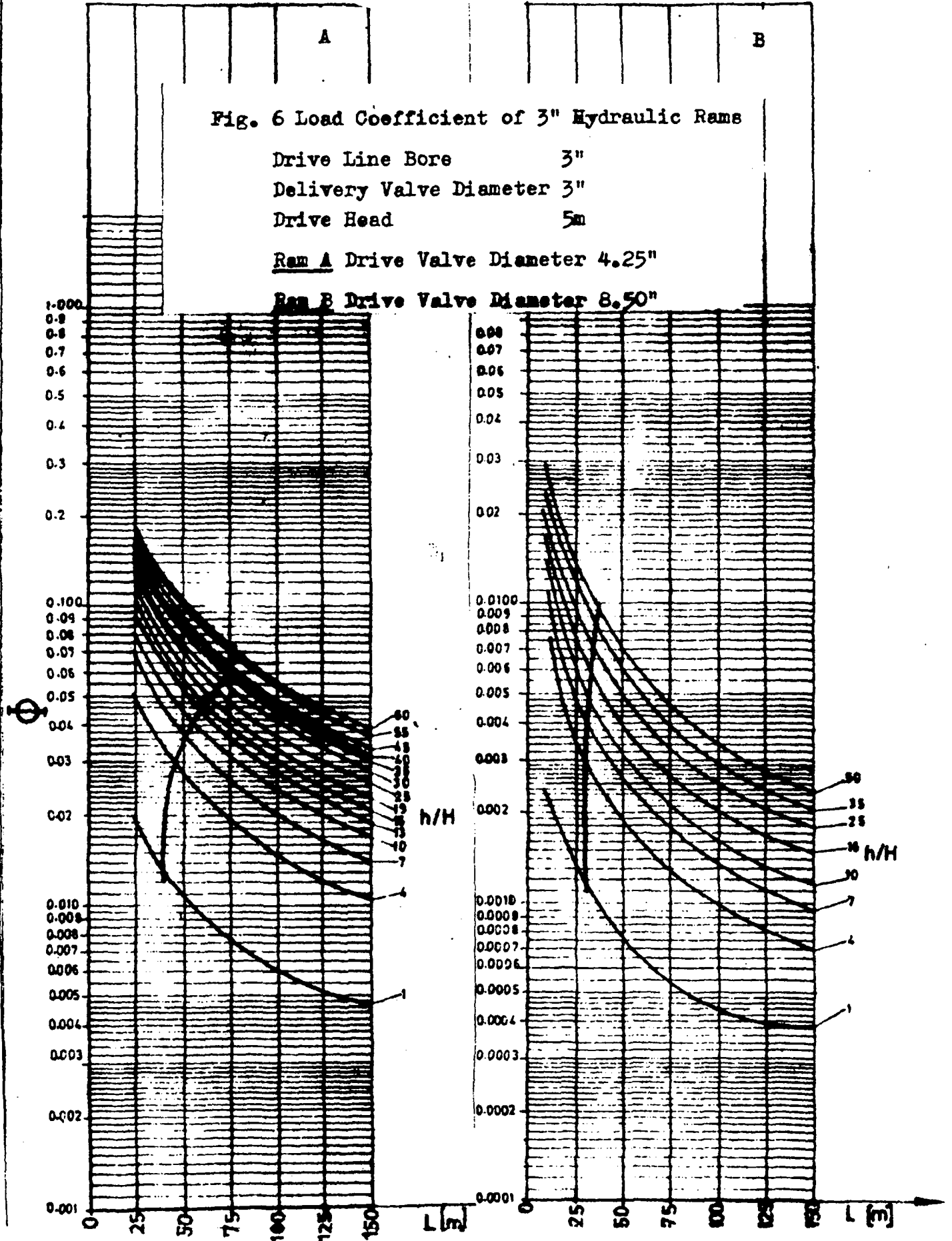

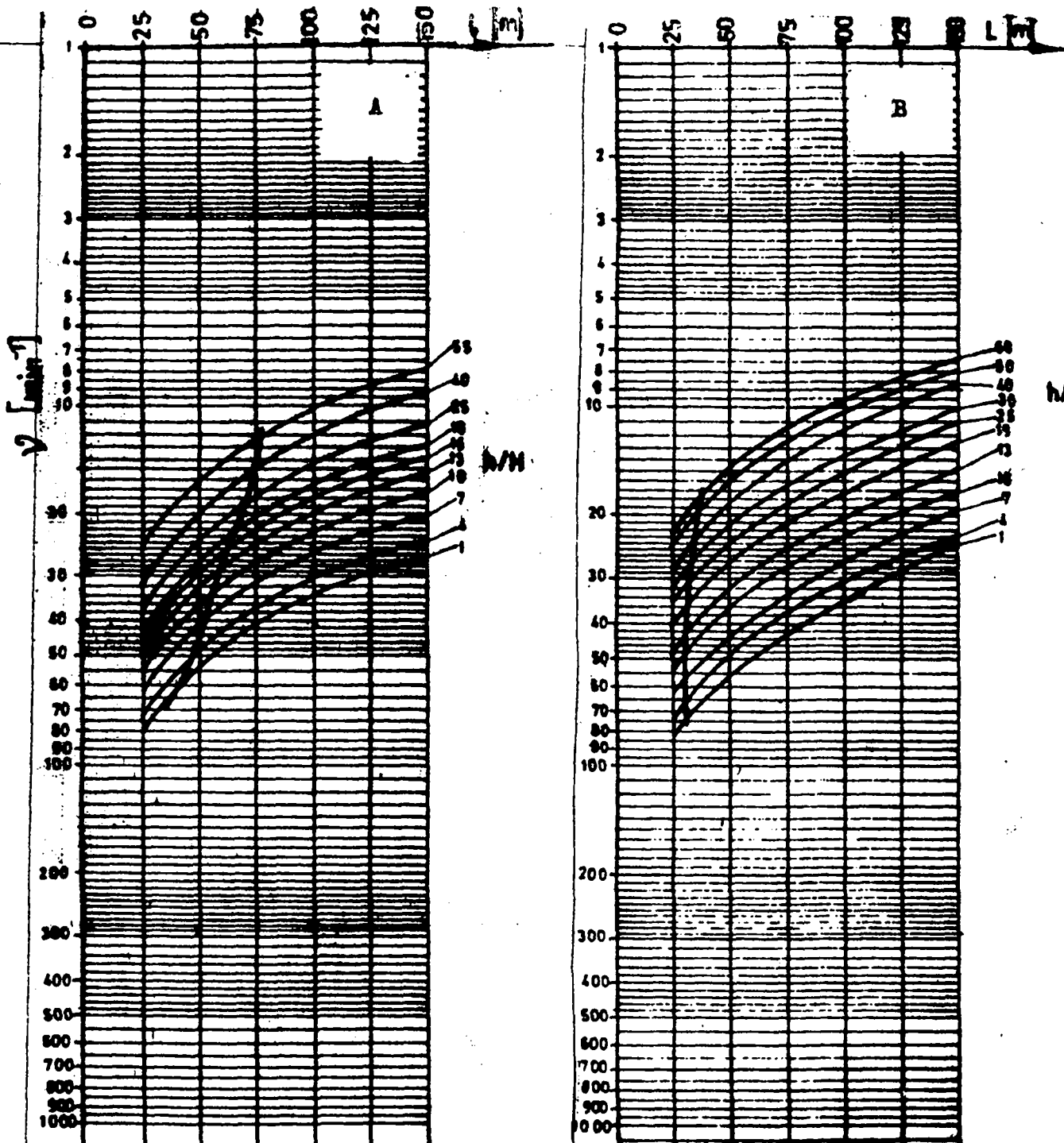

Fig. 7 Frequency of 3" Hydraulic Rams

Drive Line Bore 3"  
Delivery Valve Diameter 3"  
Drive Head 5m

Ram A Drive Valve Diameter 4.25"

Ram B Drive Valve Diameter 8.50"



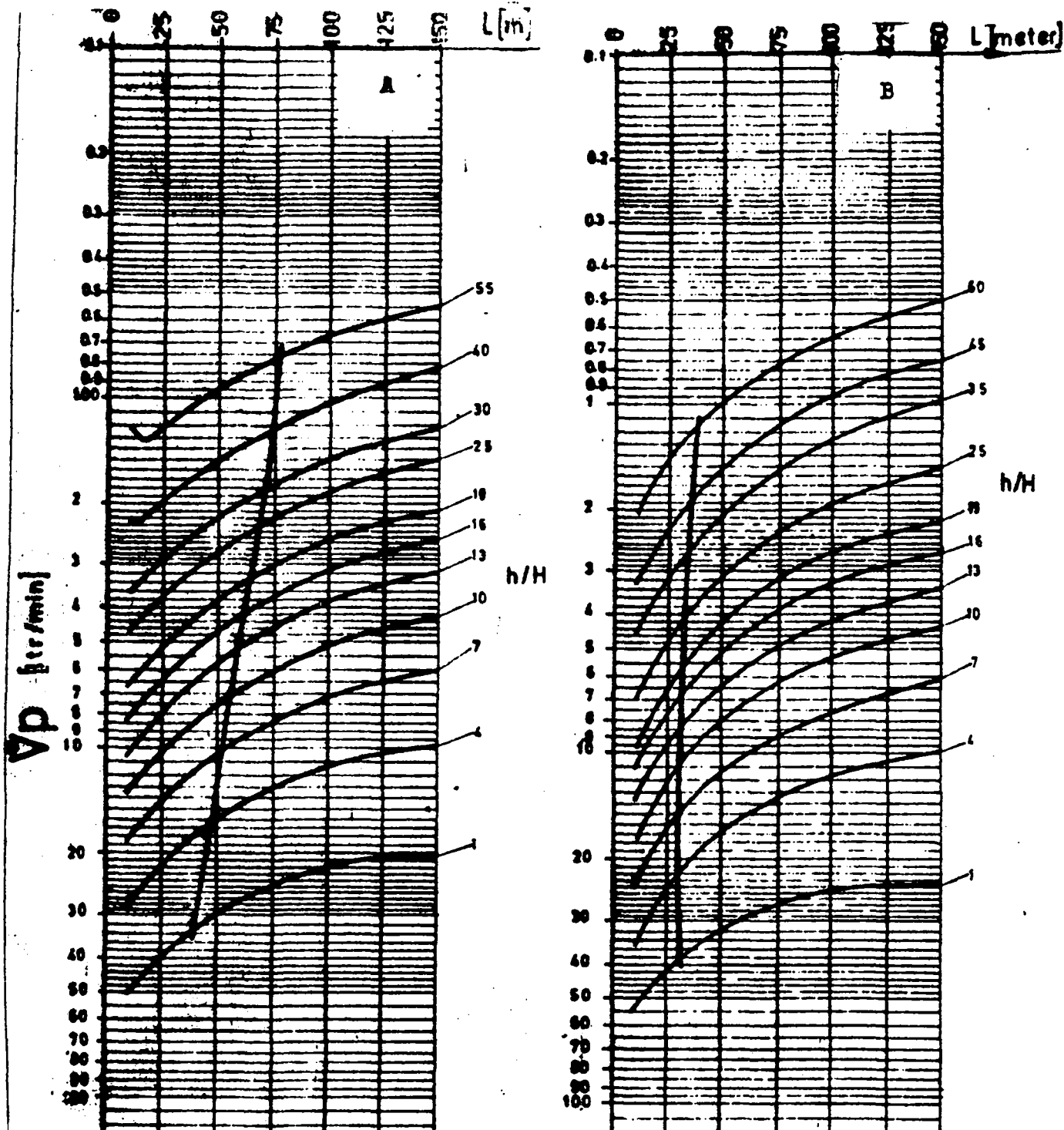

Fig. 8 Pumped Volume Flow of 3" Hydraulic Rams

Drive Line Bore 3"

Delivery Valve Diameter 3"

Drive Head 5m

Ram A Drive Valve Diameter 4.25"

Ram B Drive Valve Diameter 8.50"

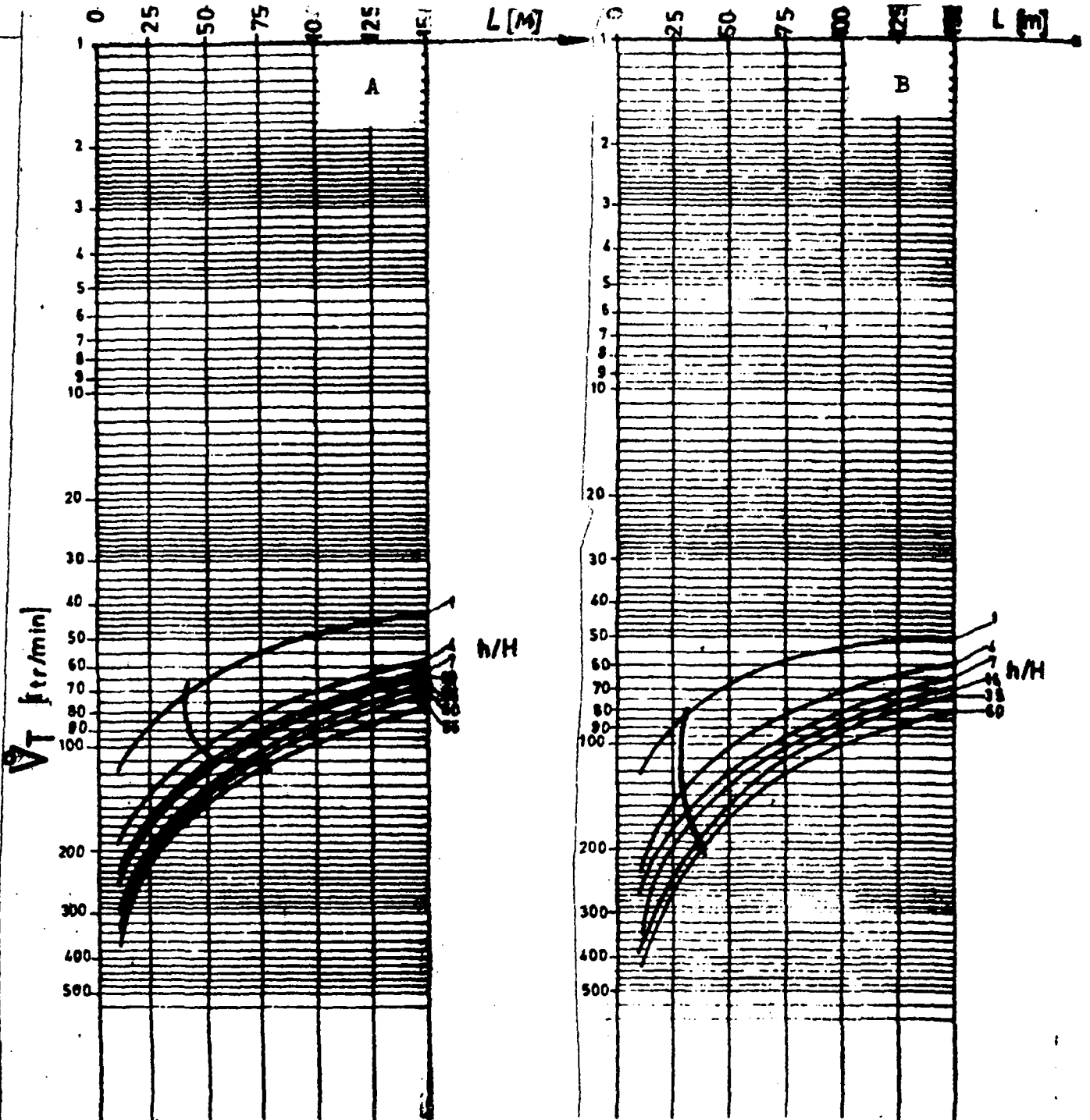

Fig. 9 Total Volume Flow of 3" Hydraulic Rams

Drive Line Bore 3"

Delivery Valve Diameter 3"

Drive Head 5m

Ram A Drive Valve Diameter 4.25"

Ram B Drive Valve Diameter 8.50"

HYDRAM WORKSHOP PARTICIPANTS

Tanzania

Mr. William A. Baynit  
Sociologist  
Centre for Agricultural Mechanization and Rural Technology (CAMARTEC)  
Box 764  
Arusha  
Tanzania

Mr. Apollo I. Bwojo  
Mechanical Engineer  
Water Resources Institute  
P.O. Box 35059  
Dar Es Salaam  
Tanzania

Mr. S.S. Jandu  
Jandu Plumbers  
P.O. Box 409  
Arusha  
Tanzania

Mr. A.N. Kaaya  
CAMARTEC  
Box 764  
Arusha  
Tanzania

Mr. S.A. Mbwette  
Faculty of Engineering  
Department of Civil Engineering  
Box 35131  
University of Dar Es Salaam  
Tanzania

Mr. L. Msimbe  
Research Engineer  
Ministry of Water, Energy and Minerals  
Box 9153  
Dar Es Salaam  
Tanzania

Mr. A. Mzee  
Chief Maintenance Engineer  
Ministry of Water, Energy and Minerals  
Box 9153  
Dar Es Salaam  
Tanzania

Mr. E.M. Ngaiza  
Director-General  
CAMARTEC  
Box 764  
Arusha  
Tanzania

**TANZANIA**  
(cont'd)

Mr. E. Th. Protzen  
Technical Manager  
Institute for Production Innovation  
University of Dar Es Salaam  
P.O. Box 35075  
Dar Es Salaam  
Tanzania

Mr. Alexander Schlusser  
CAMARTEC  
Arusha  
Tanzania

Mr. David Tulapona  
CAMARTEC  
Arusha  
Tanzania

**Uganda**

Mr. Patrick Kahangire  
Hydrologist  
Ministry of Lands, Minerals and Water Resources  
Box 19  
Entebbe  
Uganda

Mr. Robert Kilama  
Mechanical Engineer  
Ministry of Lands, Minerals and Water Resources  
Box 19  
Entebbe  
Uganda

**Zambia**

Mr. V. Liyanage  
Senior Project Engineer  
Technology Development and Advisory Unit (TDAU)  
Lusaka Campus  
The University of Zambia  
P.O. Box 32379  
Lusaka  
Zambia

**CANADA**

Mr. James Chauvin  
Program Officer  
International Development Research Centre  
P.O. Box 8500  
Ottawa, Ontario K1G 3H9  
Canada

Mr. Alex Redekopp  
Senior Program Officer  
International Development Research Centre  
P.O. Box 8500  
Ottawa, Ontario K1G 3H9  
Canada

Dr. Eric Schiller  
Civil Engineering Department  
University of Ottawa  
Ottawa, Ontario K1N 9B4