

M 2171  
EPA-600/2-83/026

255.1  
85FI

FILTRATION OF GIARDIA CYSTS AND OTHER SUBSTANCES  
Volume 2. Slow Sand Filtration

by

William D. Bellamy  
Gary P. Silverman  
David W. Hendricks  
Colorado State University  
Fort Collins, Colorado 80523

Cooperative Agreement No. CR808650-02

Project Officer

Gary S. Logsdon  
Drinking Water Research Division  
Water Environmental Research Laboratory  
Cincinnati, Ohio 45268

WATER ENVIRONMENTAL RESEARCH LABORATORY  
OFFICE OF RESEARCH AND DEVELOPMENT  
U.S. ENVIRONMENTAL PROTECTION AGENCY  
CINCINNATI, OHIO 45268

REFERENCE CAN BE  
MADE TO THE WATER SUPPLY AND  
SANITATION DIVISION

255.1-85FI-5884

reduce the filter's removal capabilities for approximately one day; this is the reason for Huisman (1979), Johnson (1978) and The World Health Organization (1980) recommending filtering to waste after the filter is scraped.

The amount of time for the biological population to mature in a new sand filter, also called ripening or curing, and provide stable and full treatment was found to vary. The World Health Organization (1980) says it can take from a few weeks to a few months. Fox (1983) found "about 30 days" were required to bring particle and bacterial effluents down to a stable level. Den Blanken (1982) found that phenol removal was complete after 50 days of maturing the filter. All researchers agree that a curing time for a new filter is required before the filter operates at its fullest potential.

TECHNICAL REPORT DATA <i>(Please read instructions on the reverse before completing)</i>		
1. REPORT NO. EPA-600/2-85/026	2.	3. RECIPIENT'S ACCESSION NO.
4. TITLE AND SUBTITLE Filtration of <u>Giardia</u> Cysts and Other Substances, Volume 2: Slow Sand Filtration	5. REPORT DATE	
	6. PERFORMING ORGANIZATION CODE	
7. AUTHOR(S) W.D. Bellamy, G.P. Silverman, and D.W. Hendricks	8. PERFORMING ORGANIZATION REPORT NO.	
9. PERFORMING ORGANIZATION NAME AND ADDRESS Colorado State University Department of Civil Engineering Fort Collins, Colorado 80523	10. PROGRAM ELEMENT NO.	
	11. CONTRACT/GRANT NO. CR 808650	
12. SPONSORING AGENCY NAME AND ADDRESS Water Engineering Research Laboratory - Cincinnati, OH Office of Research and Development U. S. Environmental Protection Agency Cincinnati, Ohio 45268	13. TYPE OF REPORT AND PERIOD COVERED Final 3/81 - 2/84	
	14. SPONSORING AGENCY CODE EPA/600/14	
15. SUPPLEMENTARY NOTES Project Officer: Gary S. Logsdon (513) 684-7345 See also: Volume 1, Diatomaceous Earth Filtration, EPA-600/2-84-114; Volume 3, Rapid Rate Filtration, EPA-600/2-85-027		
16. ABSTRACT Slow sand filtration research was conducted at Colorado State University in two phases, using 1 foot diameter filters. Phase I results showed removal of <u>Giardia</u> cysts exceeded 99.9 percent for the three hydraulic loading rates used. The most important operating condition was the development of a biopopulation within the sand bed. Removals of total coliform bacteria related well to the development of the biopopulation within the sand bed showing, 90 percent removal for a new sand bed operated at 0.40 m/hr filtration rate, and 99.99 percent removal for a mature sand bed and established schmutzdecke operated at 0.04 m/hr. Removals of standard plate count bacteria ranged usually from 88 to 91 percent because organisms were continuously sloughed from within the sand bed. Turbidity removal was usually 27 to 40 percent, as the turbidity within Horsetooth Reservoir was comprised mostly of mineral particles 1 um or smaller, which passed readily through the filters. In Phase II removals of total coliform bacteria ranged from 60 percent for the filter maintained with no biological activity (e.g. chlorinated between tests), to 99.9 percent for the filter having nutrients added. Removal for the control filter averaged 97 percent. Using larger sand size of 0.62 mm instead of 0.29 mm caused a decline in percent removals, as did using 48 cm depth instead of 97 cm. Operation at 2°C instead of 17°C caused a decline in percent removal to 92 percent compared to 99 percent for the control filter.		
17. KEY WORDS AND DOCUMENT ANALYSIS		
a. DESCRIPTORS	b. IDENTIFIERS/OPEN ENDED TERMS	c. COSATI Field/Group
18. DISTRIBUTION STATEMENT RELEASE TO PUBLIC	19. SECURITY CLASS (This Report) UNCLASSIFIED	21. NO. OF PAGES 327
	20. SECURITY CLASS (This page) UNCLASSIFIED	22. PRICE

DISCLAIMER

The information in this document has been funded wholly or in part by the United States Environmental Protection Agency under assistance agreement number CR808650-02 to Colorado State University. It has been subject to the Agency's peer and administrative review, and it has been approved for publication as an EPA document. Mention of trade names or commercial products does not constitute endorsement or recommendation for use.



## FOREWORD

The U.S. Environmental Protection Agency is charged by Congress with protecting the Nation's land, air, and water systems. Under a mandate of national environmental laws, the agency strives to formulate and implement actions leading to a compatible balance between human activities and the ability of natural systems to support and nurture life. The Clean Water Act, the Safe Drinking Water Act, and the Toxics Substances Control Act are three of the major congressional laws that provide the framework for restoring and maintaining the integrity of our Nation's water, for preserving and enhancing the water we drink, and for protecting the environment from toxic substances. These laws direct the EPA to perform research to define our environmental problems, measure the impacts, and search for solutions.

The Water Engineering Research Laboratory is that component of EPA's Research and Development program concerned with preventing, treating, and managing municipal and industrial wastewater discharges; establishing practices to control and remove contaminants from drinking water and to prevent its deterioration during storage and distribution; and assessing the nature and controllability of releases of toxic substances to the air, water, and land from manufacturing processes and subsequent product uses. This publication is one of the products of that research and provides a vital communication link between the researcher and the user community.

Giardiasis is an intestinal disease reported with increasing frequency especially in the western and northeastern United States. The disease is caused by ingestion of cysts of the protozoan Giardia lamblia. The cysts are commonly found in the cold clear streams of mountain environments, which are used as a source water supply by many communities. This report investigates the effectiveness of slow sand filtration in removal of Giardia cysts and other substances of concern, delineating the role of selected design criteria and operating conditions. Slow sand filtration is examined as a part of the EPA research program focused on water treatment problems of small communities.

This report is the second of three volumes entitled, "Filtration of Giardia Cysts and Other Substances." Volume 1 is subtitled, "Diatomaceous Earth Filtration," and Volume 3 is subtitled, "Rapid Rate Filtration."

Francis T. Mayo, Director  
Water Engineering Research Laboratory

## ABSTRACT

Water treatment efficiency of slow sand filtration was studied under various design and operating conditions to ascertain removal of Giardia lamblia cysts, total coliform bacteria, standard plate count bacteria, particles, and turbidity. Filter removals were assessed at hydraulic loading rates of 0.04, 0.12, and 0.40 m/hr, temperatures of 0°, 5°, and 17°C, effective sand sizes of 0.128, 0.278 and 0.615 mm, sand bed depths of 0.48 and 0.97 m, influent Giardia cyst concentrations of 50 to 5000 cysts/liter; and various conditions of filter biological maturity and influent bacteria concentrations. Testing was conducted from July 1981 to December 1983 with nine pilot filters, each 1 foot in diameter.

Results showed that slow sand filtration is an effective water treatment technology. Giardia cyst removal was virtually 100 percent for a biologically mature filter. Total and fecal coliform removal was approximately 99 percent. Particle removal averaged 98 percent. Standard plate count bacteria removal ranged from negative removals to 99 percent, depending on the influent concentration. Turbidity displayed a unique ability to pass through the filters, a characteristic not previously reported, and removal ranged from 0 to 40 percent.

Changes in process variables resulted in decreased filter efficiency for increased hydraulic loading rate, increased sand size, decreased bed depth, and decreased biological activity. Giardia removal was influenced by the biological maturity of the filter but not by the variables mentioned above. During filter start-up, Giardia removal was 98 percent; and once the filter was mature, removal was virtually complete.

Slow sand filtration is effective in removing Giardia cysts and bacteria and should be considered as an alternative to rapid sand filtration during treatment process selection for small communities. As a general principle, on-site pilot testing should precede any selection or installation of a water treatment system.

This report was submitted in fulfillment of Contract No. CR808650-02 by Colorado State University under the sponsorship of the U.S. Environmental Protection Agency. This report covers the period March 1, 1981 to February 28, 1984, and work was completed as of February 28, 1984.

## CONTENTS

Disclaimer.....	ii
Foreword.....	iii
Abstract.....	iv
Tables.....	viii
Figures.....	xv
Acknowledgments.....	xxii
1. Introduction.....	1
Investigation.....	1
Basis for investigation.....	1
Purpose.....	1
Objective.....	1
Scope.....	2
Significance.....	2
Principles of slow sand filtration.....	3
Literature review.....	4
<u>Giardia lamblia</u> .....	4
History.....	4
Structure.....	4
Disease.....	6
Waterborne transmission.....	6
Slow sand siltration.....	7
History.....	7
Performance.....	8
Removal mechanisms.....	10
2. Summary and Conclusions.....	12
<u>Giardia</u> cyst removal.....	12
Total coliform removal.....	12
Standard plate count removal.....	12
Turbidity removal.....	13
Particle removal.....	13
Process variables.....	13
Applications for slow sand filtration.....	21
3. Experimentation.....	24
Pilot plants.....	24
Phase I.....	24
Phase II and III.....	32
Experimentation program.....	41
Design of experiments.....	41

Phases of experimentation.....	41
Test run.....	48
Testing period.....	48
Testing procedures.....	49
Giardia testing and cyst procurement.....	49
Giardia sampling.....	51
Bacteria testing and procurement.....	59
Bacteria sampling.....	62
Turbidity and particle sampling.....	62
Analysis.....	62
Giardia cyst analysis.....	62
Bacteriological analysis.....	63
Turbidity and particle analyses.....	63
Data handling.....	63
Quality control.....	65
Flow-measurement and metering pumps.....	65
Turbidity meters.....	65
Temperature.....	66
Pressure.....	66
Microbiological controls.....	66
Automatic autoclave.....	66
Manual autoclave.....	66
Incubator and water bath.....	66
Bacterial analyses.....	66
Membrane filters.....	67
Data entry.....	67
4. Results and Discussion.....	68
Role of process variables.....	68
Hydraulic loading rate.....	68
Sand size.....	74
Sand bed depth.....	79
Temperature.....	81
Influent contaminant concentration.....	83
Modes of operation.....	86
Effect of modes of operation on the Biological community.....	86
Filter start-up.....	91
Schmutzdecke removal.....	106
Steady state operation.....	107
Biological community importance.....	109
Removals of dependent variables.....	113
Giardia cyst removal.....	113
Total coliform removal.....	113
Fecal coliform removal.....	115
Standard plate count removal.....	117
Turbidity removal.....	119
Turbidity characterization.....	122
Temperature.....	126
Headloss.....	126
Disinfection.....	127

Particle removal.....	127
Monitoring of filter operations.....	127
Hydraulic loading.....	127
Mechanism.....	128
Turbidity removal.....	130
References.....	131

APPENDICES

A - Results of Phase I Experiments for Slow Sand Filtration 7/1981 - 1/1983.....	135
B - Results of Phase II and Phase III Experiments for Slow Sand Filtration 2/1983 - 12/1983.....	164
C - Giardia Data for Slow Sand Filtration 2/1982 - 1/1983.....	183
D - Total Coliform Data for Slow Sand Filtration.....	190
E - Fecal Coliform Data for Slow Sand Filtration 2/1982 - 6/1982.....	201
F - Standard Plate Count Data for Slow Sand Filtration 2/1982 - 1/1983.....	204
G - Turbidity Data for Slow Sand Filtration.....	216
H - Particle Count Data for Slow Sand Filtration.....	230
I - Graphical Operating Histories for Temperature, Headloss and Hydraulic Loading Rate 7/1981 - 1/1983.....	233
J - Quality Control Data Sheets.....	243
K - Giardia Procurement, Analysis and Detection Limits.....	253
L - X-Ray Diffraction Analysis of Horsetooth Reservoir Water Turbidity.....	281
M - Disinfection by Chlorination.....	285
N - Particle Counting Protocol.....	289
O - Data Sheets and Computer Coding Forms.....	292
P - Synthetic Sewage Formula.....	304

TABLES

<u>Number</u>		<u>Page</u>
1	Different species names given to <u>Giardia</u> found in specific hosts (Jakubowski, 1979) .....	5
2	Performance of slow sand filters (van Dijk, 1982) .....	9
3	Media specifications for gravel underdrain .....	30
4	List of equipment and apurtenances used in the operation of the Phase I slow sand filtration pilot plant .....	31
5	List of equipment and apurtenances used for the Phase II and III slow sand filtration pilot plant .....	39
6	Dependent and independent variables of Phase I testing .....	42
7	Dependent and independent variables of Phase II testing .....	43
8	Dependent and independent variables for Phase III testing .....	44
9	Phase I experimentation program for slow sand filtration .....	45
10	Phase II experimentation program for slow sand filtration .....	46
11	Phase III experimental program for slow sand filtration .....	47
12	Sources used in obtaining dog fecal samples containing <u>Giardia lamblia</u> cysts .....	50
13	Slow sand filter treatment efficiency as effected by hydraulic loading rate, Phase I test .....	73

<u>Number</u>		<u>Page</u>
14	Correlation of total coliform breakthroughs to hydraulic loading.....	74
15	Effect of sand size on slow sand filter treatment efficiency, Phase III testing.....	76
16	Standard plate count bacteria removal as affected by sand size, Phase III testing. Filter 1 was the control. Bacteria concentrations are geometric means calculated from data abstracted from Table F-6, Appendix F.....	76
17	Effect of sand size on slow sand filter treatment efficiency while being operated at 5°C, Phase II testing.....	77
18	Slow sand filter treatment efficiency as affected by a diatomaceous earth coating of the sand surface, Phase III testing.....	78
19	<u>Giardia</u> cyst removal as affected by an effective sand size of 0.615 mm.....	78
20	Slow sand filter treatment efficiency as affected by sand bed depth, Phase II testing.....	79
21	Bacterial and turbidity removal by slow sand filtration as effected by temperature. Both filters had hydraulic loading rates of 0.12 m/hr and effective sand size of 0.278 mm.....	81
22	Effects of temperature on standard plate count bacteria removal by slow sand filtration, Phase III testing.....	81
23	<u>Giardia</u> removal by slow sand filtration as effected by temperature, Phase I testing.....	82
24	<u>Giardia</u> removal as effected by temperature, all filters were biologically mature and operated at 0.12 m/hr.....	83
25	<u>Giardia</u> removal as effected by a filter in the start-up mode of operation versus a filter with a mature biopopulation. Phase I results.....	103
26	Effect of sand replacement on <u>Giardia</u> cyst removal.....	105

<u>Number</u>		<u>Page</u>
27	<u>Giardia</u> removal by slow sand filtration as effected by schmutzdecke removal. Each of these tests were conducted within one day of removing the schmutzdecke.....	106
28	<u>Giardia</u> removal by slow sand filtration as effected by the maturity of the biological population. Tests with established schmutzdeckes.....	108
29	Effect of the biological community on filter effectiveness. These results are for established filter operations.....	109
30	Summary of results for <u>Giardia</u> cyst experiments for Phase I slow sand filtration, 2/1982 to 1/1983.....	110
31	Summary of results for <u>Giardia</u> cyst experiments for Phase II slow sand filtration, 4/83 to 8/83.....	112
32	Total coliform removal by slow sand filtration.....	114
33	Fecal coliform removal by slow sand filtration. Phase I results.....	116
34	Standard plate count bacteria removal by slow sand filtration.....	117
35	Turbidity removal by slow sand filtration.....	121
36	Typical size of particles in natural water (Bead, 1977).....	124
A-1	Results of experiments for slow sand Filter No. 1, v = 0.04 m/h.....	136
A-2	Results of experiments for slow sand Filter No. 2, v = 0.12 m/hr.....	145
A-3	Results of experiments for slow sand Filter No. 3, v = 0.40 m/h.....	155
B-1	Phase II slow sand filter data for Filter No. 1, the control filter.....	165
B-2	Phase II slow sand filter data for Filter No. 2, this filter has 1/2 the sand depth.....	168



<u>Number</u>		<u>Page</u>
B-3	Phase II slow sand filter data for Filter No. 3, this filter had chlorine added when tests were not being performed.....	171
B-4	Phase II slow sand filter data for Filter No. 4, this filter had nutrients added.....	174
B-5	Phase II slow sand filter data for Filter No. 5, this filter had large sand and was kept at 5°C.....	177
B-6	Phase II slow sand filter data for Filter No. 6, this filter was operated at 5°C.....	180
C-1	<u>Giardia</u> data for slow sand filtration, Filter No. 1 v = 0.04 m/h.....	184
C-2	<u>Giardia</u> data for slow sand filtration, Filter No. 2 v = 0.12 m/h.....	186
C-3	<u>Giardia</u> data for slow sand filtration, Filter No. 3 v = 0.40 m/h.....	188
D-1	Total coliform data for slow sand filtration, 7/1981 - 1/1983.....	191
D-2	Statistical summary of total coliform data in Table D-1.....	193
D-3	Total coliform data for Phase II slow sand filtration testing.....	194
D-4	Statistical summary of total coliform data in Table D-3.....	197
D-5	Total coliform data for Phase III slow sand filtration testing.....	198
D-6	Statistical summary of total coliform data in Table D-5.....	200
E-1	Fecal coliform data for slow sand filtration, 2/1982 - 6/1982.....	202
E-2	Statistical summary of fecal coliform data in Table E-1.....	203
F-1	Standard plate count data for slow sand filtration 2/1982 - 1/1983.....	205

<u>Number</u>		<u>Page</u>
F-2	Statistical summary of standard plate count data in Table F-1.....	208
F-3	Standard plate count data for Phase II slow sand filtration testing.....	209
F-4	Statistical summary of standard plate count data in Table F-3.....	212
F-5	Standard plate count data for Phase III slow sand filtration testing.....	213
F-6	Statistical summary of standard plate count data in Table F-5.....	215
G-1	Turbidity data for slow sand filtration, 7/1981 - 1/1983.....	217
G-2	Statistical summary of turbidity data in Table G-1.....	222
G-3	Turbidity data for Phase II slow sand filtration testing.....	223
G-4	Statistical summary of standard plate count bacteria data in Table G-3.....	226
G-5	Turbidity data for Phase III slow sand filtration testing.....	227
G-6	Statistical summary of turbidity data in Table G-5.....	229
H-1	Particle count data for slow sand filtration.....	231
H-2	Statistical summary of particle count data in Table H-1.....	232
J-1	Pressure gauge standardization data sheet.....	247
J-2	Dial thermometer standardization data sheet.....	248
J-3	Mercury thermometer standardization data sheet.....	249
J-4	National Bureau of Standards calibration certificate.....	250
J-5	Equipment operation record data sheet.....	251
J-6	Turbidity meter standardization data sheet.....	252

<u>Number</u>		<u>Page</u>
K-1	Cyst concentration by membrane filter sampling compared cyst concentration in source tank as determined by grab sample. Analysis by micropipette technique for both sampling methods. Tests conducted in laboratory of Dr. Charles Hibler, July 1982.....	259
K-2	Comparison of cyst recovered by sampling milk cooler feed tank water using membrane filters with cyst concentrations in tank as computed after adding cyst concentrate suspension. Analyses performed during slow sand filter experiments.....	260
K-3	<u>Giardia</u> cysts counted by three individuals using the micropipette technique at 1:1 dilution.....	271
K-4	<u>Giardia</u> cysts counted by three individuals using the micropipette technique at 1:5 dilution.....	271
K-5	<u>Giardia</u> cysts counted by three individuals using the Stoll technique.....	273
K-6	<u>Giardia</u> cysts recovered after passage through the push-pull pump and the filter.....	275
K-7	<u>Giardia</u> cysts/mL determined to be present in the tank prior to trial. Direct micropipette counts, 1:1 dilution of 1 cc samples.....	277
K-8	<u>Giardia</u> cysts/mL obtained following the push-pull pump and filtering through the nucleopore filter. All counts performed by direct micropipette, 1:5 dilution.....	278
K-9	<u>Giardia</u> cysts/mL obtained using the vacuum pump to pull sample through the nucleopore filter. All counts performed by direct micropipette, 1:5 dilution.....	279
M-1	Disinfection of effluent water from diatomaceous earth filtration test, Celite 503.....	288
N-1	Coulter Counter calibration worksheet.....	291
O-1	Operational data computer coding form, Phase I.....	293
O-2	<u>Giardia</u> data computer coding form, Phase I.....	294
O-3	Total coliform data computer coding form, Phase I.....	295
O-4	Standard plate count data computer coding form, Phase I.....	296

<u>Number</u>		<u>Page</u>
O-5	Particle count data computer coding form, Phase I.....	297
O-6	Operational data, total coliform, standard plate count, <u>Giardia</u> , dissolved oxygen, and particle data computer coding for Phases II and III.....	298
O-7	<u>Giardia</u> data analysis worksheet, all phases.....	299
O-8	Total coliform data analysis worksheet, all phases.....	300
O-9	Standard plate count data analysis worksheet, all phases.....	301
O-10	Particle count data analysis worksheet, all phases.....	302
O-11	Equipment list and experimental variable record, Phase I.....	303
P-1	Nutrient recipe for addition to slow sand Filter 4.....	305

FIGURES

<u>Number</u>		<u>Page</u>
1	Sketches of a) trophozoite, and b) cyst stages of <i>Giardia lamblia</i> (Jakubowski and Hoff, 1979).....	5
2	Effect of hydraulic loading on slow sand filtration performance. The points shown represent experimental results in Figure 4-1. The dotted line is hypothetical.....	14
3	Effect of sand size on slow sand filtration performance. The points shown represent experimental results in Figure 4-5. The dotted line is hypothetical.....	15
4	Effect of sand bed depth on slow sand filtration performance. The points shown represent experimental results in Figure 4-8. The dotted line is hypothetical.....	16
5	Effect of temperature on slow sand filtration performance. The points shown represent experimental results in Figure 4-9. The dotted line is hypothetical.....	17
6	Effect of biological activity on slow sand filtration performance. The points shown represent experimental results in Figure 4-17. The dotted line is hypothetical.....	18
7	Effect of influent contaminant concentration on slow sand filtration performance. The points shown represent experimental results in Figure 4-7. The dotted line is hypothetical.....	19
8	Effect of biological maturity within the filtration zones on slow sand filtration performance. The points shown represent experimental results in Figure 4-23. The dotted line is hypothetical.....	20

<u>Number</u>		<u>Page</u>
9	Trade offs of process variables for equal treatment efficiency in slow sand filtration. The response surface is an isopleth; it is a surface of equal treatment. The testing ranges for process variables are shown; they are for guidance only.....	22
10	Flow schematic of slow sand filter pilot plant for Phase I experimentation.....	25
11	Photograph of the slow sand pilot filter for Phase I experimentation.....	26
12	Temperature controlled milk cooler used as raw water storage tank for Phase I slow sand filter experimentation.....	27
13	Pressure slow sand filter cross-section and appurtenances for Phase I experimentation.....	28
14	Sieve analysis of sand used for Phase I slow sand filtration testing.....	29
15	Gravel support plate.....	30
16	Flow schematic of slow sand filter pilot plant for Phase II and Phase III experiments.....	33
17	Photograph of Phase II and III slow sand filter pilot plant.....	34
18	Gravity slow sand filter cross section and appurtenances for Phase II and Phase III experimentation.....	35
19	Sieve analysis of sand used for Phase II and III slow sand filtration testing. This is the sand used in the control filter (No. 1) and Filters 2, 3, 4 and 6.....	36
20	Sieve analysis of sand used for Phase II and III slow sand filtration testing. This is the large sand size used in Filter 5.....	37
21	Sieve analysis of sand used for Phase III slow sand filtration testing. This is the smallest sand used. It was placed in Filter 3.....	38

<u>Number</u>		<u>Page</u>
22	Constant head tank used for the Phase II and III slow sand filter pilot plant.....	40
23	Electrical control panel used for the Phase II and III slow sand filter pilot plant.....	40
24	Assembled 142 mm diameter filter holder used in testing for <u>Giardia</u> cysts.....	52
25	The 5 $\mu$ m pore size 142 mm diameter polycarbonate filter used for sampling <u>Giardia</u> cysts.....	52
26	Membrane filter and pump setup used to concentrate an influent <u>Giardia</u> cyst sample.....	53
27	Aspirator connected to effluent piping for membrane filter holder to draw off excess water.....	53
28	Spraying the top of the membrane filter holder with distilled water.....	55
29	Spraying the membrane support and the membrane filter with distilled water.....	55
30	Spraying the bottom of the membrane filter holder with distilled water.....	56
31	Emptying the <u>Giardia</u> cyst collection dish into sample jar.....	56
32	Washing membrane filter holder with hot, soapy water to make the filter <u>Giardia</u> "free".....	57
33	Schematic drawings of the three alternate flow paths during different steps of filter effluent sampling.....	58
34	Membrane filter sampling for <u>Giardia</u> cysts on effluent of slow sand filter.....	60
35	Coulter particle counter model TA II R used in slow sand filtration testing.....	64
36	Coulter Counter R aperture stand.....	64
37	Effect of hydraulic loading rate on total coliform bacteria percent removal. The plotted points are geometric mean removals for all operating conditions. The data were abstracted from Table 4-1.....	69

<u>Number</u>		<u>Page</u>
38	Effect of hydraulic loading rate on turbidity percent removal. The plotted points are average removals for all operating conditions. The data were abstracted from Table 4-1.....	70
39	Effect of hydraulic loading rate on standard plate count bacteria percent removal. The plotted points are geometric mean removals for all operating conditions. The data were abstracted from Table 4-1.....	71
40	Effect of hydraulic loading rate on <u>Giardia</u> percent removal. The plotted points are average removals for all operating conditions. The data were abstracted from Table 4-1.....	72
41	Effect of sand size on removal of total coliform bacteria for slow sand filtration, Phase II and Phase III experiments.....	75
42	Effect of sand bed depth on slow sand filter performance.....	80
43	Effluent coliform concentration as affected by influent coliform concentration at hydraulic loading = 0.12 m/h. When no coliforms were found in an effluent sample the value was plotted at $10^{-1}$ but 0 was used in the calculation of the mean.....	84
44	Effluent standard plate count bacteria concentration as affected by influent standard plate count concentration at hydraulic loading = 0.12 m/h.....	85
45	Percent coliform remaining in effluent as affected by influent coliform concentration at hydraulic loading rate = 0.12 m/h.....	87
46	Percent standard plate count bacteria remaining in effluent as affected by influent standard plate count bacteria concentration at hydraulic loading rate = 0.12 m/h.....	88
47	Influent and effluent total coliform concentration for Filter 1 and Filter 5 for the first 115 days of Phase II testing. The influent was common to both filters.....	89



<u>Number</u>		<u>Page</u>
48	State of the biological community for different modes of operation and at different locations within the filter. Growth refers to the process of establishing a biological community, i.e. biological growth. Mature refers to an established biocommunity, i.e., at steady state.....	90
49	Effect of temperature, sand size, one half sand bed depth, no biological growth, i.e., chlorinated and nutrient addition on filter start-up and mature operation. The plotted points are weekly averages for the first 10 weeks of operation.....	92
50	Influent and effluent total coliform concentrations during start-up and for mature operations of Filters 1 and 2, Phase II testing. Filter 1 was the control and Filter 2 had one half the sand bed depth. The plotted values were abstracted from Appendix D.....	93
51	Influent and effluent total coliform concentrations during start-up and for mature operations of Filters 1 and 3, Phase II testing. Filter 1 was the control and Filter 3 was chlorinated between test runs. The plotted values were abstracted from Appendix D.....	94
52	Influent and effluent total coliform concentrations during start-up and for mature operations of Filters 1 and 4, Phase II testing. Filter 1 was the control and Filter 4 had nutrients added. The plotted values were abstracted from Appendix D.....	95
53	Influent and effluent total coliform concentrations during start-up for mature operations of Filters 1 and 5, Phase II testing. Filter 1 was the control and Filter 5 had 0.165 mm sand and was operated at 5°C. The plotted values were abstracted from Appendix D.....	96
54	Influent and effluent total coliform concentrations during start-up and for mature operations of Filters 1 and 6, Phase II testing. Filter 1 was the control and Filter 6 was operated at 5°C. The plotted values were abstracted from Appendix D.....	97
55	Improved turbidity removal over time for Filter 1, Phase II testing. Filter 1 is the control filter.....	99
56	Improved turbidity removal over time for Filter 4, Phase II testing. Filter 4 had nutrients added.....	100

<u>Number</u>		<u>Page</u>
57	Influent and effluent turbidity concentration for Filter 3. Sodium hypochlorate at 5 mg/L was metered to this filter continuously except during test run. Plot demonstrates increase in turbidity after each chlorination and dechlorination of the filter.....	101
58	Influent and effluent standard plate count bacteria concentration for Filter 3. Plot demonstrates the increase in SPC bacteria after each chlorination and dechlorination of the filter.....	102
59	Effect of conditions of schmutzdecke and bed on percent remaining of total coliforms for three hydraulic loading rates.....	104
60	Influent versus effluent standard plate count bacteria concentrations flow slow sand filtration. Values obtained from a mature filter operating with an effective sand size of 0.287 mm, at a hydraulic loading rate of 0.12 m/h and at a temperature of 17°C, Filter 1, Phase II and III testing.....	118
61	Generalization of the influence of influent bacteria concentrations on effluent bacteria concentrations for slow sand filtration.....	120
62	Effect of hydraulic loading on the composition of the effluent bacteria concentration (from Hazen, 1913).....	120
63	Turbidity removal, from Horsetooth Reservoir water, by membrane filters of different sizes.....	123
I-1	Graphical operating history of temperature, headloss and hydraulic loading rate for Filter 1, Phase I operation.....	234
I-2	Graphical operating history of temperature, headloss and hydraulic loading rate for Filter 2, Phase I operation.....	235
I-3	Graphical operating history of temperature, headloss and hydraulic loading rate for Filter 3, Phase I operation.....	236
I-4	Graphical operating history of temperature, headloss and hydraulic loading rate for Filter 1, Phase II and Phase II operation.....	237

<u>Number</u>		<u>Page</u>
I-5	Graphical operating history of temperature, headloss and hydraulic loading rate for Filter 2, Phase II and Phase II operation.....	238
I-6	Graphical operating history of temperature, headloss and hydraulic loading rate for Filter 3, Phase II and Phase III operation.....	239
I-7	Graphical operating history of temperature, headloss and hydraulic loading rate for Filter 4, Phase II and Phase III operation.....	240
I-8	Graphical operating history of temperature, headloss and hydraulic loading rate for Filter 5, Phase II and Phase III operation.....	241
I-9	Graphical operating history of temperature, headloss and hydraulic loading rate for Filter 6, Phase II and Phase II operation.....	242
J-1	Calibration curve for Fluid Metering Inc. Pump, Model RPD R .....	244
J-2	Calibration curve for March Piston Pump, Model 212 R .....	245
J-3	Calibration curve for March Piston Pump, Model 210-10R R ..	246
K-1	<u>Giardia</u> analysis record form.....	257
L-1	Horsetooth Reservoir looking from the north to south.....	282

## ACKNOWLEDGMENTS

Special appreciation is extended to Dr. C. P. Hibler and his staff from the Department of Pathology for their assistance and expertise in analysis of samples for Giardia cysts. Thanks also to the late Dr. S. M. Morrison, Donna Howell, Roy Warbington and Kirke Martin of the Department of Microbiology for their assistance in bacterial analyses. Dr. Keith Elmund, Supervisor of Environmental Monitoring for the City of Fort Collins, collaborated on chlorine residual tests of slow sand filter effluent. His help is gratefully acknowledged. Mr. Gary P. Silverman, provided valuable assistance during the experimentation. Sandra S. Page prepared the report in the format through several stages of editing and revision. Ewald Patzer and his shop staff built the pilot plant facility.

Dr. Gary S. Logsdon, the U.S. Environmental Protection Agency project officer, offered valuable support and advice throughout the project.

## SECTION 1

### INTRODUCTION

#### INVESTIGATION

##### Basis for Investigation

This study of Giardia lamblia removal by slow sand filtration was initiated as one part of a cooperative agreement between Colorado State University and the U.S. Environmental Protection Agency (EPA). Its objective was to ascertain removals of Giardia lamblia cysts by slow sand filtration, rapid sand filtration, and diatomaceous earth filtration. This document describes the results of the slow sand filtration research.

Slow sand filtration was included in the cooperative agreement because of EPA interest in ascertaining appropriate treatment technologies for small communities. Outbreaks of giardiasis have been associated most often with small community water systems. A frequent cause of these outbreaks has been problems in operation of their rapid rate filtration systems. Slow sand filtration and diatomaceous earth filtration are possible alternative technologies, especially appropriate for small communities. Though slow sand filtration is well established in other parts of the world as an effective treatment technology, it has not been used extensively in the United States, where it has been largely pre-empted by rapid rate filtration since about the turn of the century. Thus there was interest by EPA in developing additional first hand knowledge about the process and in assessing its effectiveness in removal of Giardia lamblia cysts.

##### Purpose

The purpose of this study was to ascertain the suitability of slow sand filtration as an appropriate water treatment technology for small communities that could have an existing or potential Giardia problem. The project included developing an understanding of the respective roles of process variables. Recommendations were made for design and operating guidelines, with emphasis on removal of Giardia lamblia cysts.

##### Objective

The objective of this research was to determine the removal efficiencies of slow sand filtration for Giardia cysts, coliform bacteria, standard plate count bacteria, turbidity, and particles as influenced by process variables.

The process variables of interest included design parameters (hydraulic loading rate, sand bed depth, and sand size), and operating conditions (age of filter schmutzdecke, effect of schmutzdecke removal, age and condition of the biopopulation within the sand bed, effect of nutrient addition on accelerating biological development, concentrations of influent contaminants, and water temperature).

### Scope

The research was a classical experimental investigation in which the magnitude of one independent variable was changed while the others were maintained constant and the response of the dependent variables were measured. The dependent variables were: *Giardia* cysts, total coliform bacteria, fecal coliform bacteria, standard plate count bacteria, turbidity and particles. The independent variables were: hydraulic loading rate, sand bed depth, sand size, temperature, role of schmutzdecke, condition of the biological population within the sand bed and the effect of accelerating biological development. The "biological population" refers to the aggregate population of bacteria, protozoa, and higher organisms attached to the sand grains comprising the sand bed. The level of activity of this bio-mass is dependent upon the nutrient loading on the filter and the time elapsed since startup.

The experimentation was performed in three phases using laboratory scale pilot filters. The Phase I experimentation was conducted during the period August 1981 to December 1982, using three 1 foot-diameter filters. The three filters were operated at hydraulic loading rates of 0.04 m/hr, 0.12 m/hr, and 0.40 m/hr. This work ascertained how hydraulic loading rate, biological condition of the sand bed, the schmutzdecke, and influent concentrations of bacteria and cysts affected the removal of bacteria, cysts, turbidity and particles.

Based on the results of the Phase I tests, Phase II was designed to assess the influences of sand bed depth, sand size, biological activity in the sand bed, and temperature on filter performance. To accomplish six additional 1 foot-diameter pilot filters were built. One was a control; the other five were operated the same as the control, but a difference in one of the process variables was imposed for each of the other five filters, respectively. The Phase II testing period was from February to September 1983.

The Phase II test results lead to the design of the Phase III experiments, which were conducted with the same six pilot filters. The Phase III experimentation was an extension of the Phase II program and was designed to improve the resolution of the influence of temperature, sand size, and schmutzdecke development on filter performance.

### Significance

Rapid rate filtration is the water treatment technology used most extensively in the United States. Often it has proved inappropriate for

small communities. Essentially, rapid-rate filtration is a "high" technology that requires skilled operation, which in turn means trained operators who are retained in service by the community. Even with skilled operation, the process may not be effective, especially when cold, clear waters are used as a supply. This observation is borne out by the increasingly frequent outbreaks of giardiasis, many of which have been associated with improper operation of the rapid rate filtration process.

Slow sand filtration, on the other hand, is a "passive" technology that requires little attention because the filter effectiveness occurs naturally from the development of its schmutzdecke and of the bio-population within the sand bed. Knowledge of the relationships between removal effectiveness and process variables (the focus of this research) provides a basis for recommending improved design and operating guidelines for slow sand filtration. From this knowledge, design engineers, regulatory personnel, and water utilities have a basis for considering slow sand filtration as an alternative technology.

#### PRINCIPLES OF SLOW SAND FILTRATION

Slow sand filtration is a "passive" filtration process—that is, it is subject to very little control by an operator. There is no chemical addition or backwash. The raw water is passed through a sand bed where physical, chemical and biological mechanisms remove contaminants. The most important removal mechanism has been recently attributed to the biological processes, (Huisman and Wood 1974, van Dijk 1982, Taylor 1974). The first two authors outline general principles of design and operation and have served as important references for practice.

During operation, biological growth occurs within the sand bed and within the gravel support. That this phenomenon is important was a conclusion from the research reported within. Also, a layer of inert deposits and biological material, called the "schmutzdecke," forms on the surface of the sand bed. The schmutzdecke and the biological growth within the sand bed, which may require weeks or months to develop, have the most important roles in the effectiveness of slow sand filtration. The literature emphasizes the importance of the schmutzdecke.

Operation of a slow sand filter requires two periodic tasks: (1) removal of the schmutzdecke and (2) replacing the sand. The schmutzdecke is removed by scraping the top 2 cm from the surface of the sand bed after the filter bed is drained. The procedure is done when the filter headloss exceeds about 1 to 1.5 meters. The removal interval depends on the contaminants present in the raw water and the hydraulic loading rate. Weeks or months of operation should be expected between removals. Since operating expenses will be affected by the frequency of schmutzdecke removal, pilot testing is advisable to ascertain this important operating parameter.

Replacing sand is necessary after repeated scrapings have reduced the sand bed in the filter to its lowest acceptable depth, which is about 0.3 to 0.5 m. The method of replacing sand recommended by Huisman (1974) is to

remove the remaining 0.3 to 0.5 m of sand down to the gravel support layer, add new sand to one half the design depth, and place the sand previously removed on top of the new sand. This procedure results in clean sand being placed in the bottom half of the filter bed and formerly biologically active sand in the top half. It also provides for a complete exchange of sand over time, which alleviates any potential problem of excessive silt accumulation and possible clogging of the filter bed. Several years of operation should be expected before this operation is necessary.

The slow sand filter is designed to operate at hydraulic loading rates ranging from 0.04 m/hr to 0.40 m/hr. By contrast, the lowest expected hydraulic loading rate in rapid rate filtration is 13.6 m/hr (2 gpm/ft<sup>2</sup>). The effective sand sizes used range from 0.15 mm to 0.35 mm, with a uniformity coefficient of less than 2. In rapid rate filtration using dual media the effective sizes are about 0.45 mm for the sand and about 0.90 mm for the anthracite. The sand bed depth ranges from 60 cm to 120 cm, and is supported by 30 cm to 50 cm of graded gravel.

To summarize, slow sand filtration is a "passive" process, requiring development of biological activity within the filter. Because of the low hydraulic loading rates, a large filter bed area is required.

#### LITERATURE REVIEW

#### Giardia Lamblia

##### History—

The protozoan Giardia was first observed in 1681 by Antony van Leeuwenhoek (Dobel, 1932). Since that time the genus and species nomenclature have undergone changes and are still being disputed. In 1882 the organism was given the genus name of Giardia by Joseph Kunstler. The genus name Lamblia was used by Raphael Blanchard in 1888, and this name is still used to some extent in Europe (Levine, 1979). The species lamblia was established in 1915 by Charles Stiles and prior to this was synonymously known as intestinalis, duodenalis, and enterica.

Table 1 lists the different names used to identify Giardia cysts from different hosts. It is believed that the species in group 1 are the same and, therefore, may be cross-transmitted between host of different animal species. Hibler (Davies et al. 1983) has reported self infection using Giardia cysts obtained from dogs. The characteristics of Giardia lamblia cysts and Giardia canis cysts are identical, and there is every reason to believe that the two are the same organism. This is corroborated in a different manner by Hewlett, et al. (1982) who established that Giardia cysts from humans can infect dogs. Thus the designation Giardia lamblia is proper for the Giardia cysts used in this research, which were obtained from dog fecal samples.

##### Structure—

The organism has two life stages: a reproductive trophozoite stage and a dormant cyst stage. Sketches representing these two life stages are shown



Table 1. Different species names given to Giardia found in specific hosts (Jakubowski, 1979).

DIFFERENT SPECIES IDENTIFICATION		HOST ORIGINATED FROM
1. Claw-like Median Bodies		
<i>Giardia lamblia</i>		Man
<i>Giardia intestinalis</i>		Man
<i>Giardia enterica</i>		Man
<i>Giardia canis</i>		Dog
<i>Giardia cati</i>		Cat
<i>Giardia bovis</i>		Ox
<i>Giardia duodenalis</i>		Rabbit
<i>Giardia simondi</i>		Rat, Mouse
2. Rounded Median Bodies		
<i>Giardia muris</i>		House Mouse, Rat, Hamster

✓ Cross-transmittance of these species has not been demonstrated.

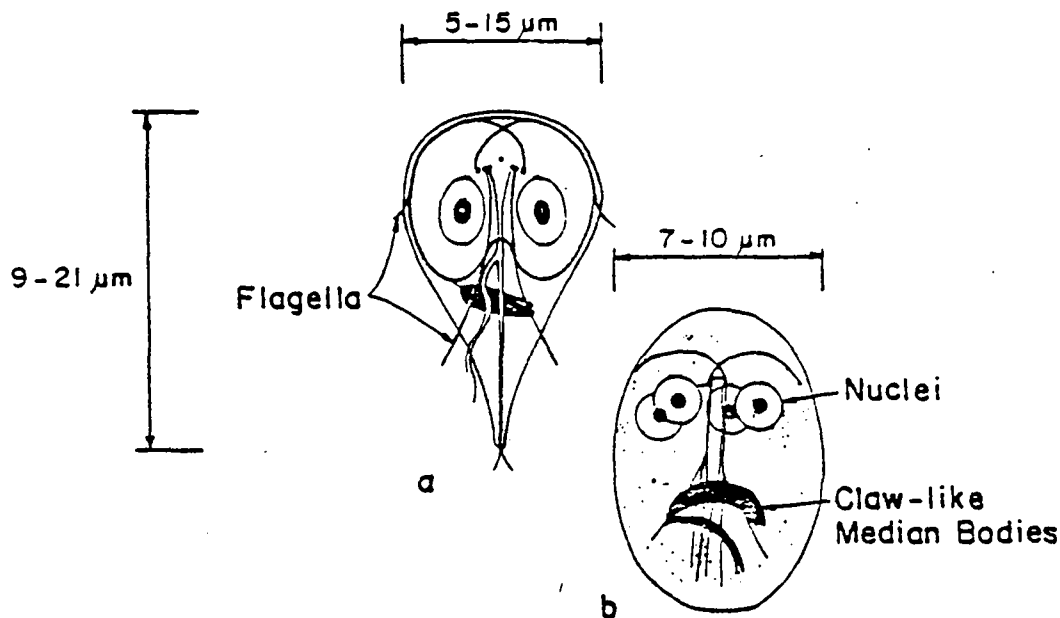

Figure 1. Sketches of a) trophozoite, and b) cyst stages of *Giardia lamblia* (Jakubowski and Hoff 1979)

in Figure 1. The trophozoite, shown in Figure 2-1a, is pear-shaped, with a broad anterior and a blunt, pointed posterior. The dorsal side is convex, while the ventral side contains a sucking disc and is concave. Its

dimensions are 9-12  $\mu\text{m}$  long by 5-15  $\mu\text{m}$  wide and 2-4  $\mu\text{m}$  thick. The trophozoite is also bilaterally symmetrical with two nuclei and eight flagella.

The cyst, shown in Figure 2-1b, is ovoid to ellipsoidal in shape with a translucent cyst wall approximately 0.3  $\mu\text{m}$  thick. Its dimensions are 8-12  $\mu\text{m}$  long by 7-10  $\mu\text{m}$  wide. Newly formed cysts have two nuclei while mature cysts usually have 4 nuclei. It is uncertain when division and doubling of organelles occurs, but during excystation two trophozoites emerge.

#### Disease—

Infection is caused by ingestion of as few as one and ten cysts (Rendtorff, 1954). Giardiasis symptoms will appear anywhere from two to thirty-five days after ingestion with one to two weeks as the most common incubation period. The cyst is the only life stage that is infectious. It survives digestive processes and harbors in the small intestine. Once exposed to Giardia lamblia the host can be a lifetime carrier. Presently, drugs with harmful side effects will cure the symptoms but the disease can recur, especially during stressful periods. The symptoms of the disease include: diarrhea, flatulence, foul stools, cramps, distention, anorexia, nausea, weight loss, belching, heartburn, headache, constipation, vomiting, fever, chills, and fatigue (Jakubowski and Hoff 1979).

#### Waterborne Transmission—

The first documented waterborne outbreak of giardiasis in the United States was in Aspen, Colorado, during the winter of 1965-1966. The town's water supply was treated with chlorine only. More than 11 percent of the 1,094 vacationing skiers surveyed over a two-month period developed giardiasis. At approximately the same time there were reports of epidemic giardiasis among travelers returning from the Soviet Union. The Center for Disease Control surveyed 1,419 members of 47 tour groups which visited the Soviet Union between 1969 and 1973. The CDC estimated 23 percent of the travelers had giardiasis (Jakubowski 1979). The largest outbreak of giardiasis in the U.S., and the first when a Giardia lamblia cyst was recovered from a municipal water supply, occurred in Rome, New York, from November 1974 to June 1975 (Shaw 1977). A total of 350 residents had laboratory-confirmed giardiasis and an estimated 5,300 others may have been symptomatic. Chlorine, again, constituted the only form of water treatment.

Outbreaks in Camas, Washington, in 1976 (Kimer 1978) and Berlin, New Hampshire, in 1977 (Lippy 1978) were the first cases in which Giardia cysts were found in filtered water supplies. Subsequent reports from Estes Park, Colorado, (Blair 1979) and Vail, Colorado (Blair 1980) substantiated the seriousness of the problem and the difficulties in adequately treating water to prevent Giardia cyst transmission.

## Slow Sand Filtration

### History--

Slow sand filtration has had a long and successful history of providing treatment for potable water use. It was first practiced at the beginning of the 19th century in Europe to remove undesirable materials from highly contaminated surface water sources. In a short period of time it became apparent that occurrences of cholera and typhoid were reduced when waters were filtered. Consequently, by the end of the 19th century most European countries, and experts in the United States, were advocating filtration for public waters and some required it by law. Slow sand filtration is widely used throughout the world and is still considered an excellent water treatment technology. The World Health Organization recommends it as the water treatment technology of choice for developing countries.

The first recorded use of slow sand filtration was in 1804 in Paisley, Scotland where John Gibb designed and constructed a filter to provide water for his bleaching business and for public purchase. Chelsea Water Company in 1829 provided the first slow sand filtration of a public water supply which was delivered through a piped distribution system (Baker, 1948). James Simpson designed and constructed the filter with a hydraulic loading rate of 0.1 m/hr which has become the standard of design (Fox, 1978). The attributes of filtered water became apparent to London's populace and in 1839 the city's commercial water suppliers began filtering their water. There were five successive increases in filter area until 1894 when the total filter surface area had reached 470,000 m<sup>2</sup> and was producing 890,000 m<sup>3</sup> of water per day. In 1852 the health benefits became so obvious that the London city government required filtration of many waters prior to public sale, and later established the Thames Conservancy Board to regulate potable water quality (Hazen, 1913).

Scientific evidence that filtration reduced the occurrence of disease was provided in 1850 when Dr. John Snow concluded that cholera was transmitted in water by "materia morbi" and that filtration could remove this substance. In 1892, a very graphic example of filtration benefits occurred in Germany. Hamburg had over 7500 people die in a typhoid epidemic while Altona, Hamburg's neighbor, had only a few typhoid deaths. Both used the Elbe river water as their water source; however, only Altona filtered the water prior to distribution (Huisman, 1974).

Continental Europe began filtering public waters by the 1850's. Filtration for Berlin began in 1856, Altona in 1860, Zurich in 1884, Hamburg in 1893 and Budapest in 1894. Hamburg's filter plant construction was done by day and night under electric lights to complete construction as soon as possible and prevent another cholera epidemic. By 1899 4.7 million cubic meters per day were being filtered in Europe (Hazen, 1913).

Europe is still using slow sand filtration as a major component in their water treatment systems, e.g., London, Zurich and Amsterdam. It was not until 1962 in Rotterdam that a large-scale rapid sand treatment plant, similar to U.S. designs, was constructed in Europe (Okun, 1962).

The use of slow sand filtration was not and is not as wide spread in the United States. The short filter runs associated with the turbid waters found in the East and Midwest caused interest in the new rapid sand technology developed in the 1890's. The first slow sand filter in the U.S. was designed by James P. Kirkwood and built in 1872 for the town of Poughkeepsie, New York. This was followed by filters in Hudson, N.Y., 1874; St. Johnsbury, VT, 187(?), and Lawrence, MA, 1894. By 1899 filtration in the U.S. had reached 1.1 million cubic meters per day but only 200,000 m<sup>3</sup>/day was by slow sand filtration.

The filters installed at Lawrence, Massachusetts were notable because of the extensive research conducted by the Massachusetts State Board of Health prior to the filter design and construction. This was the most scientific approach to design yet made. Three years of turbidity and bacteriological testing at different flow rates and sand sizes provided the proof that slow sand filtration would remove the typhoid germ which was causing up to 28 deaths per month in Lawrence. The effective sand size selected was 0.25 mm, the bed depth was 1.5 m and the hydraulic loading rate was 0.08 m/hr (McCarthy, 1974) which is within the specification recommended by the World Health Organization.

A study in 1899 for the city of Pittsburg determined that slow sand filtration removed 99 percent of the influent bacteria while rapid sand filtration removed 97-98 percent. Even though rapid sand filtration cost less to install, Hazen recommended installing slow sand based on bacterial evidence and the city proceeded with the construction of the slow sand filters.

A recent survey conducted by Slezak (1983) had 27 responses to a questionnaire concerning practices in U.S. slow sand filter plants. Although this was not a large response, there are some interesting results presented: 1) 9 of the 27 plants are less than 25 years old, 2) 17 of the 27 plants serve communities of less than 10,000 people, and 3) the filtration rates are within recommended guidelines, but 4) the effective sand sizes are usually larger than recommended, i.e., greater than 0.3 mm. This survey demonstrated that there is still interest in the U.S. for slow sand filtration, primarily for small communities.

#### Performance—

Slow sand filters have proven to be very effective in removing bacteria and virus, as well as organics and inorganics. Table 2, taken from Slow Sand Filtration for Community Water Supply in Developing Countries, summarizes the performance characteristics of slow sand filtration.

The data in Table 2 have been supported by a number of investigations. Organics including humic acids, detergents, phenols, and some herbicides have been removed from 50 to greater than 99 percent (Bergling, 1981; Burman, 1978; den Blanken 1982; Huisman, 1974; Taylor, 1974; Miller, 1980). Puramasivam (1980) demonstrated that COD removal was 67 percent with an influent of 7.5 mg/l. Burman (1979) and James (1979) determined that improved organic removal, especially for color and man-made compounds, can be

Table 2. Performance of slow sand filters (Van Dijk, 1982).

Parameter	Purification Effect
organic matter	slow sand filters produce a clear effluent, virtually free from organic matter
bacteria	between 99% and 99.99% of pathogenic bacteria may be removed; cercariae of schistosoma, cysts and ova are removed to an even higher degree; <u>E. Coli</u> are reduced by 99-99.9%
viruses	in a mature slow sand filter, viruses are virtually completely removed
color	color is significantly reduced
turbidity	raw water turbidities of 100-200 NTU can be tolerated for a few days only; a turbidity more than 50 NTU is acceptable only for a few weeks; preferably the raw water turbidity should be less than 10 NTU; for a properly designed and operated filter the effluent turbidity will be less than 1 NTU

achieved by preozonation. Total coliform removal to 99 percent has been demonstrated by almost every investigator. In addition, fecal coliforms, the spore of Clostridium sporogenes, typhoid bacteria, cholera bacteria, and the liver fluke, Schistosoma cercariae, have been shown to be removed to the detection limit (Benarde, 1971; Folymers, 1943; Hazen, 1913; Notermand, 1980). Virus removal in a biological mature filter was reported to be virtually complete (Slade, 1977; Poynter, 1977). Turbidity removal has been shown normally to be below 1 NTU, recent examples are Fox (1983), Cleasby (1983), Paramasivam (1989), and Taylor (1974).

Some inorganics are also removed. Alagarsamy (1981) showed that iron and manganese were removed from 56 to 100 percent for influents of 0.5 to 53 mg/l. Beryllium removal was found to be virtually complete and copper, lead, chromium, and zinc were all removed from 80 to greater than 90 percent for influent concentrations of 30 to 50 ppb (Schottler, 1979; Schottler, 1978). Ammonia removal is approximately 100 percent and if preozonation is used this will be true for temperatures to 0.1°C (Miller, 1980). Asbestos fibers were removed from 76 to 99.94 percent (Flickinger, 1976).

Filter effectiveness has normally been tested within the normal design ranges for hydraulic loading rate of 0.1 to 0.2 m/hr, effective sand size of 0.15 to 0.35 mm, sand bed depths greater than 0.50 m, and temperatures above 5°C. Testing beyond these limits has not been prevalent. Schalekamp (1975)

reported that rates of 0.63 m/hr would not adversely affect water quality, and Taylor (1974) reported the same for 0.4 m/hr while Huisman (1974) and van Dijk (1982) definitely recommend staying below 0.2 m/hr. Sand sizes have not been shown to affect removal when they are below 0.35 mm. The selection of size is based on contaminant penetration and ease of cleaning (Huisman, 1974). Sand bed depths above 0.6 m are recommended by van Dijk (1982) while normal operations in England achieve good results at 0.46 m (Taylor, 1974). Temperature reduces filter efficiency but the reduction varies for each contaminant. Huisman (1974) reports that *E. coli* removal will be reduced from a normally achieved 99 percent to 50 percent at 2°C. These tests and plant observations were usually made within ambient ranges of influent contaminant concentrations. As a result some of the functional relationships were not well defined because the systems were not tested under extreme conditions. Also, a number of the tests were conducted in series rather than parallel and changes in influent conditions tended to mask functional relationships.

Experimental and operating results have demonstrate the superb treatment efficiency which can be obtained with a well designed, operated and biologically mature slow sand filter. This coupled with its ease of operation make it a prime candidate for installation in small communities where higher technology techniques may not be suitable (Paramasivam, 1981; WHO, 1980; Vaillant, 1982).

#### Removal Mechanisms--

A combination of processes account for the removal of impurities in the raw water. They include straining, sedimentation, adsorption and chemical and biological activity.

Straining and sedimentation are processes normally associated with transport mechanisms. Straining will occur when a particle is too large to pass through the pores between the sand grains. This will occur at or near the surface of the sand bed and improves as the removed particles reduce the pore sizes between the surface sand grains, i.e., the *schmutzdecke*. Sedimentation is the transfer by gravity of suspended particles to the surface of the sand grains throughout the bed.

Adsorption and biological activity are closely related. Adsorption is a process by which mass attraction and attraction between opposite charges attaches impurities to the sand surfaces. These adsorption sites can occur naturally on the sand surface but more importantly are created by the biological growth i.e., zoogloal film on the sand surface. After the impurity is adsorbed the biological population will assimilate it as a food source. This occurs through competition and die off or by predatory organisms which abound in the sand bed (Huisman, 1978; Huisman, 1974).

A combination of all of the removal mechanisms occur on top, i.e., at the *schmutzdecke*, and within the sand bed. Various investigators studied the importance of each and reached different conclusions. The generally accepted belief is that the removal occurring in the sand bed is most important (Burman, 1978; Taylor, 1974). Removing the *schmutzdecke*, however, will

## SECTION 2

### SUMMARY AND CONCLUSIONS

#### GIARDIA CYST REMOVAL

Giardia cyst removal by slow sand filtration was affected only by the biological maturity of the filter. The lowest removals of Giardia cysts occurred during start-up and were about 98 percent. Once a filter had a mature microbiological population, removal was to the detection limit (i.e. approximately 100 percent). Giardia removal was not observed to be affected by hydraulic loading rate, temperature, sand size (below 0.278 mm), sand bed depth, schmutzdecke removal, or sand replacement once the biological population was mature, as qualified by the testing ranges specified for the experimental program. Whatever influences these other variables may have on removal of Giardia cysts, these influences were masked by the role of the biological population within the sand bed. The biological population within the sand bed was deemed "mature" when the removals of coliform bacteria were constant at about the 99 to 99.9 percent level or greater.

#### TOTAL COLIFORM REMOVAL

Total coliform bacteria removal was found to be approximately 99 percent for a biologically mature filter operated at a hydraulic loading rate of 0.12 m/hr and temperature of 15°C. The conditions that decrease coliform removal are: 1) cold temperature, 2) increased hydraulic loading rate, 3) large sand, 4) decreased sand bed depth, 5) decreased nutrient availability, 6) decreased level of biological activity (the chlorinated filter), 7) decreased influent contaminant concentration, 8) removal of the schmutzdecke, and 9) replacing sand. Coliform removals decreased to about 80 percent during periods when certain of these conditions were imposed. The lowest removal observed was 83 percent when the filter was operated at 5°C and had a sand with an effective size of 0.618 mm.

#### STANDARD PLATE COUNT REMOVAL

Standard plate count bacteria removal followed the same trends as coliform removal. The removal percentage depended, however, on the influent concentration. When the influent was greater than  $5 \times 10^5$  colonies per milliliter, the removal was greater than 99 percent. When the influent concentration was below 200 colonies per milliliter, the removal was less than 20 percent or negative.

This latter occurrence was determined to be caused by the discharge of 100 to 200 standard plate count bacteria per milliliter regardless of the influent concentration. This base level concentration of standard plate count bacteria in the effluent is the result of bacteria growing and then being sloughed by the filter.

#### TURBIDITY REMOVAL

Turbidity removal ranged from negative removals to 43 percent. The poor removal results were determined to be caused by the small clay particles that constitute the majority of the turbidity. These particles were shown to pass through the filter.

Turbidity removal followed trends similar to those of coliform removal. Turbidity removal improved with increased biological activity, decreased hydraulic loading, and increased temperature.

Turbidities in Horsetooth water ranged from 4 to 10 NTU, and filter effluent turbidities were nominally 3 to 7 NTU. This is not representative of the normal capabilities of slow sand filtration. These results emphasize the need to do pilot plant testing for any system before design.

#### PARTICLE REMOVALS

Particle removal in the 6.35 to 12.7  $\mu\text{m}$  range was approximately 98 percent. This size range was selected for routine measurement because it encompasses the nominal size of Giardia cysts, which is 10  $\mu\text{m}$ . Particle removal was not observed to be affected by hydraulic loading rate or temperature. Testing for particle removals was not conducted for any of the other process variables.

#### PROCESS VARIABLES

Figures 2 through 8 summarize the influences of the process variables on filter performance as determined by experimental work reported here. While removals of coliforms are illustrated, the use of this parameter characterizes removal trends in general. The influences of each process variable on removal are enumerated in the following.

1. Figure 2 shows that increased hydraulic loading decreases treatment effectiveness. This was shown in Figure 13 for Phase I testing.
2. Figure 3 shows that increasing sand size decreases treatment effectiveness. This was shown in Figure 17 for Phase II and III testing.
3. Figure 4 shows that decreasing sand bed depth decreases treatment effectiveness. This was shown in Table 20 for Phase II testing.
4. Figure 5 shows that decreasing the temperature decreases treatment effectiveness. This was shown in Table 21 for Phase II and III testing.



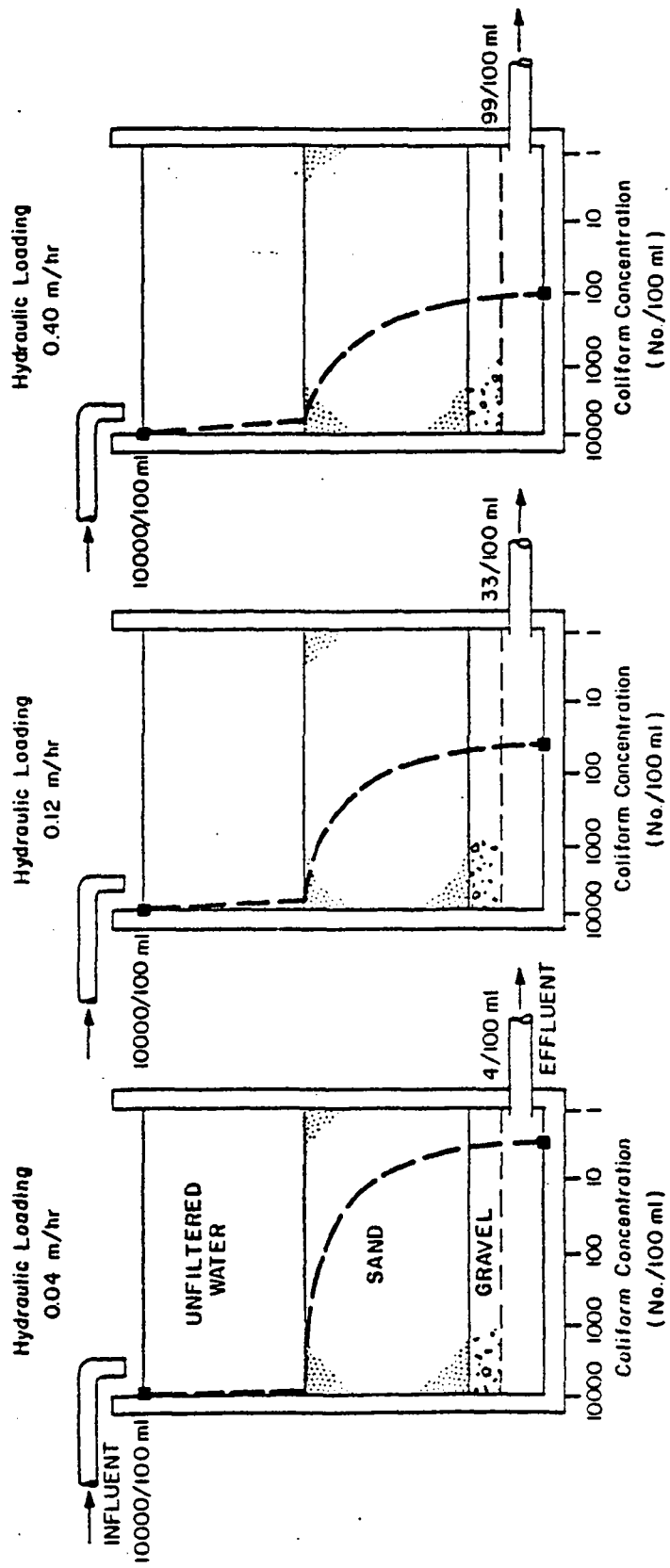

Figure 2. Effect of hydraulic loading on slow sand filtration performance. The points shown represent experimental results in Figure 37. The dotted line is hypothetical.

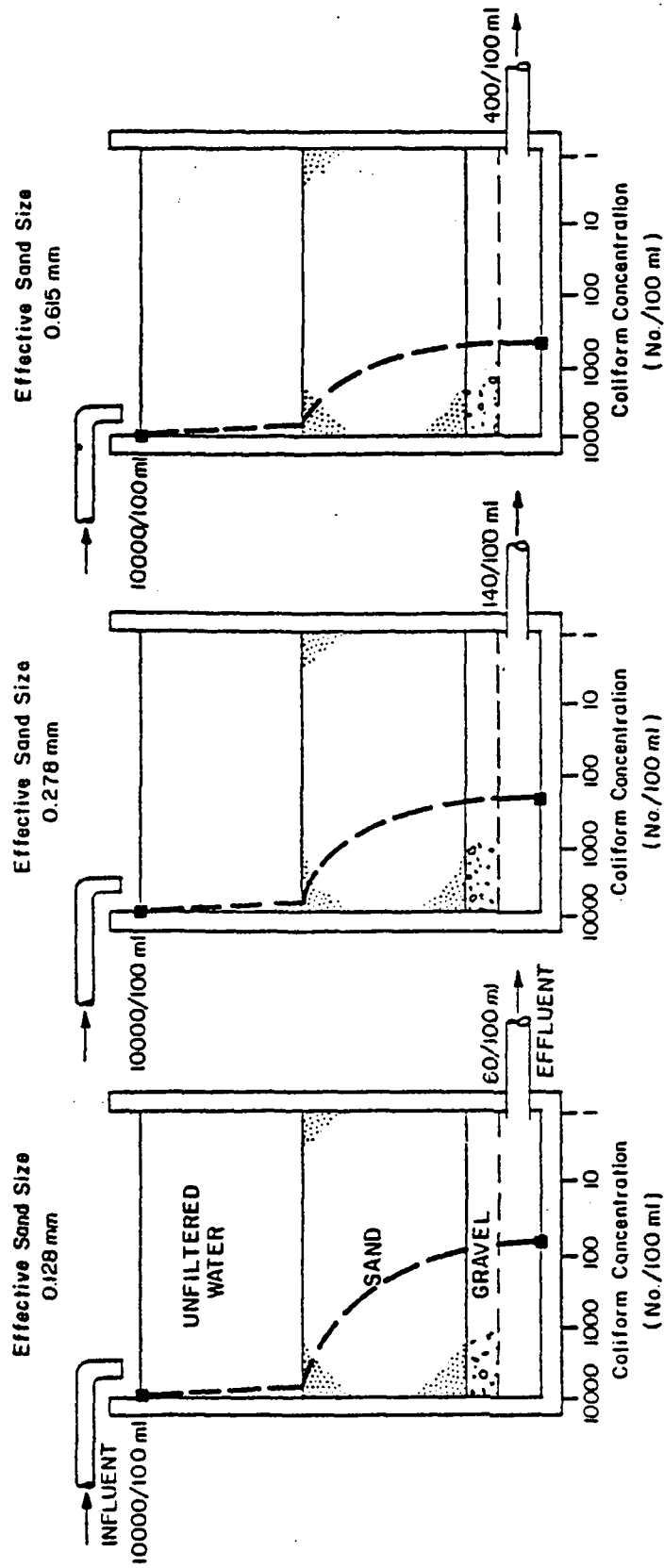

Figure 3. Effect of sand size on slow sand filtration performance. The points shown represent experimental results in Figure 41. The dotted line is hypothetical.

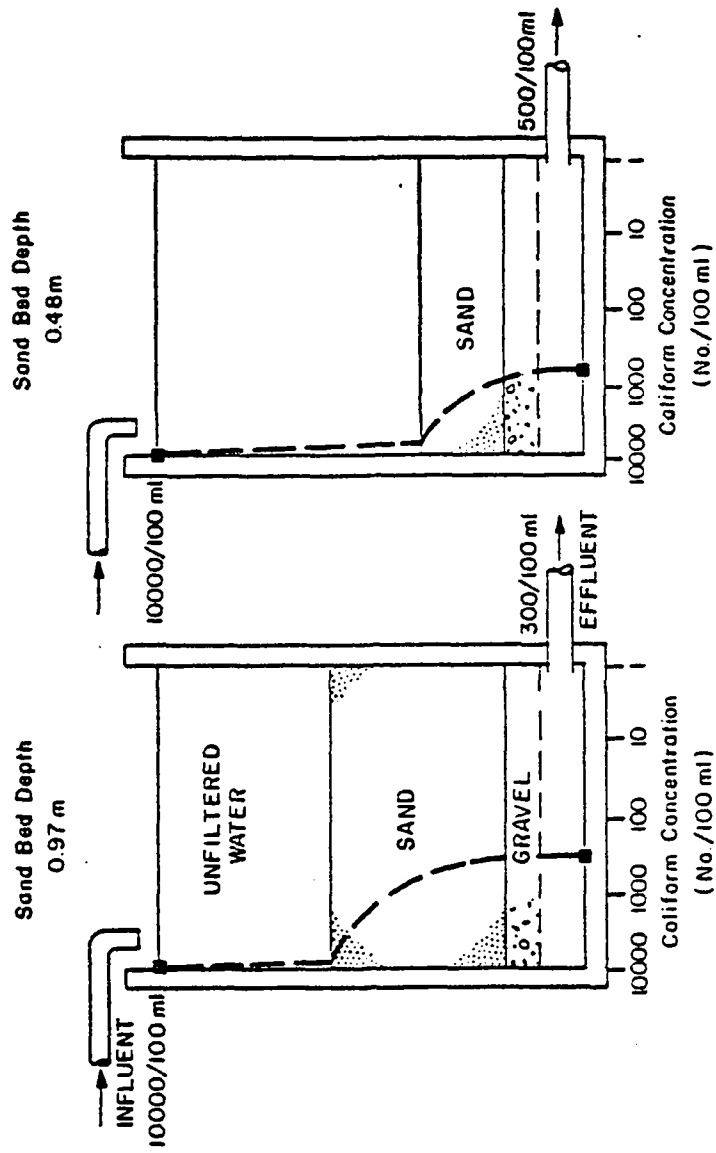

Figure 4. Effect of sand bed depth on slow sand filtration performance. The points shown represent experimental results in Table 20. The dotted line is hypothetical.

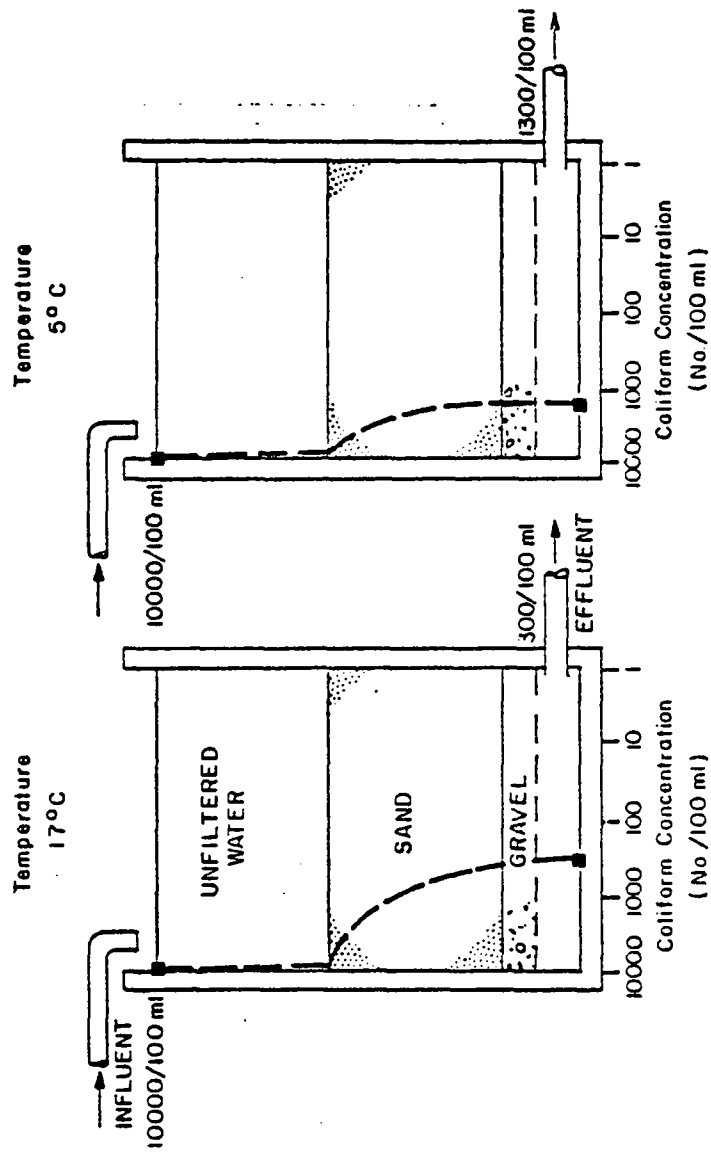

Figure 5. Effect of temperature on slow sand filtration performance. The points shown represent experimental results in Table 21. The dotted line is hypothetical.

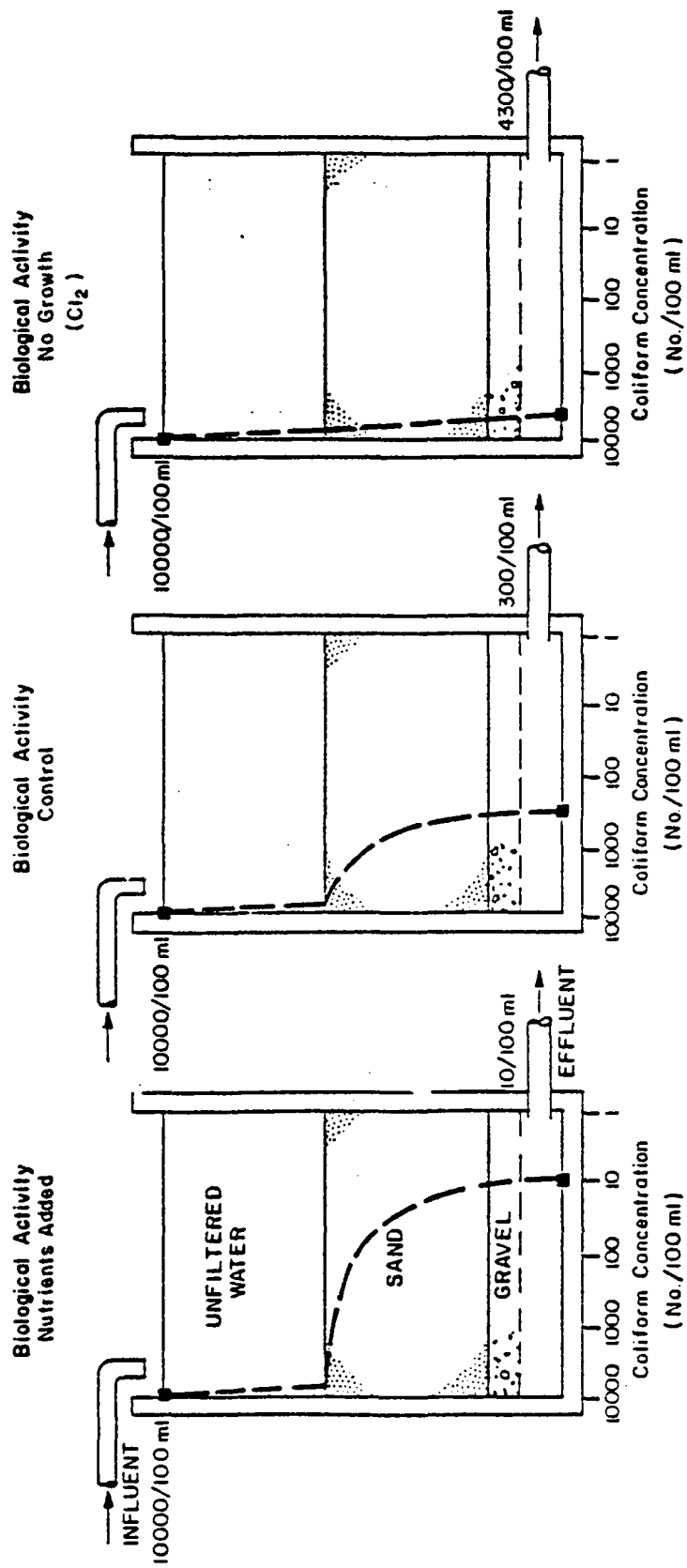

Figure 6. Effect of biological activity on slow sand filtration performance. The points shown represent experimental results in Table 29. The dotted line is hypothetical.

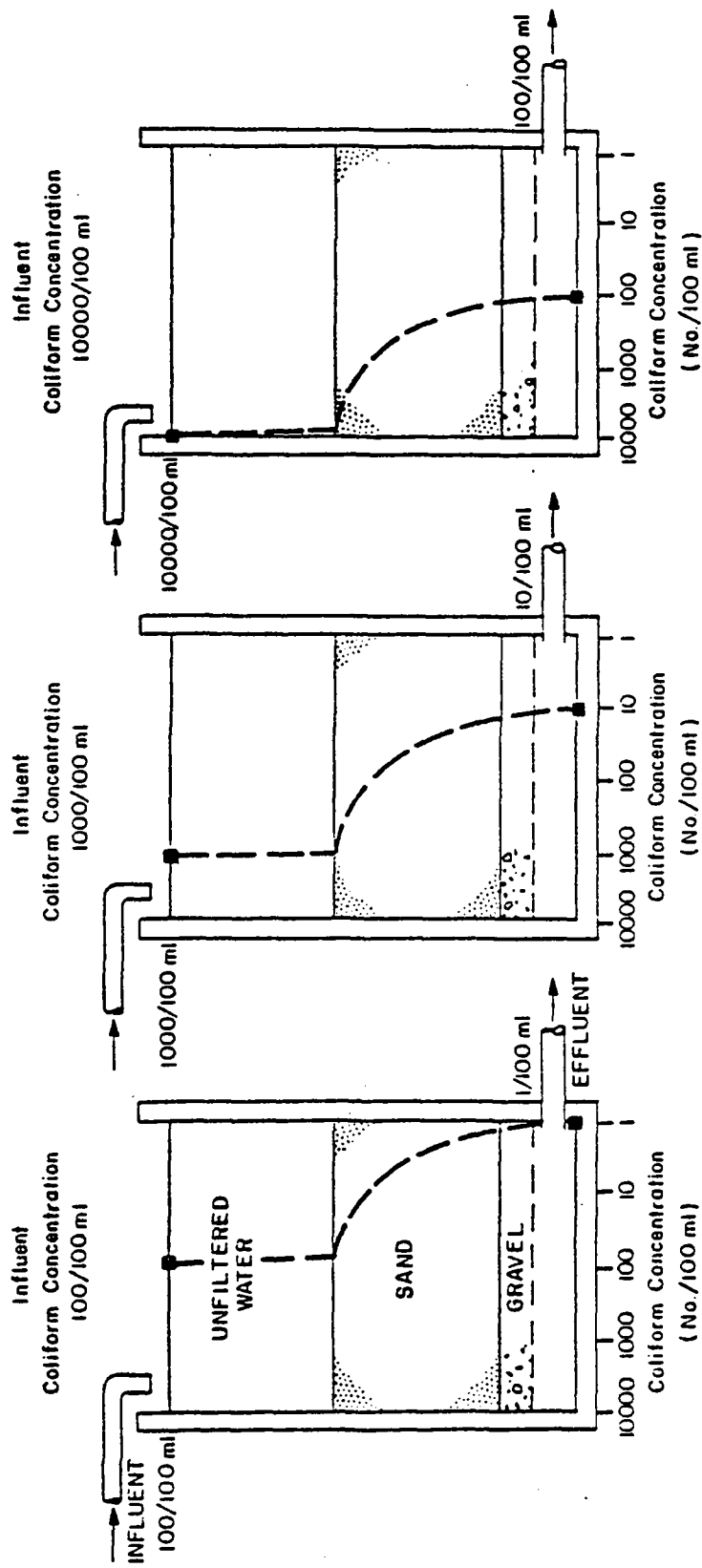

Figure 7. Effect of influent contaminant concentration on slow sand filtration performance. The points shown represent experimental results in Figure 19. The dotted line is hypothetical.

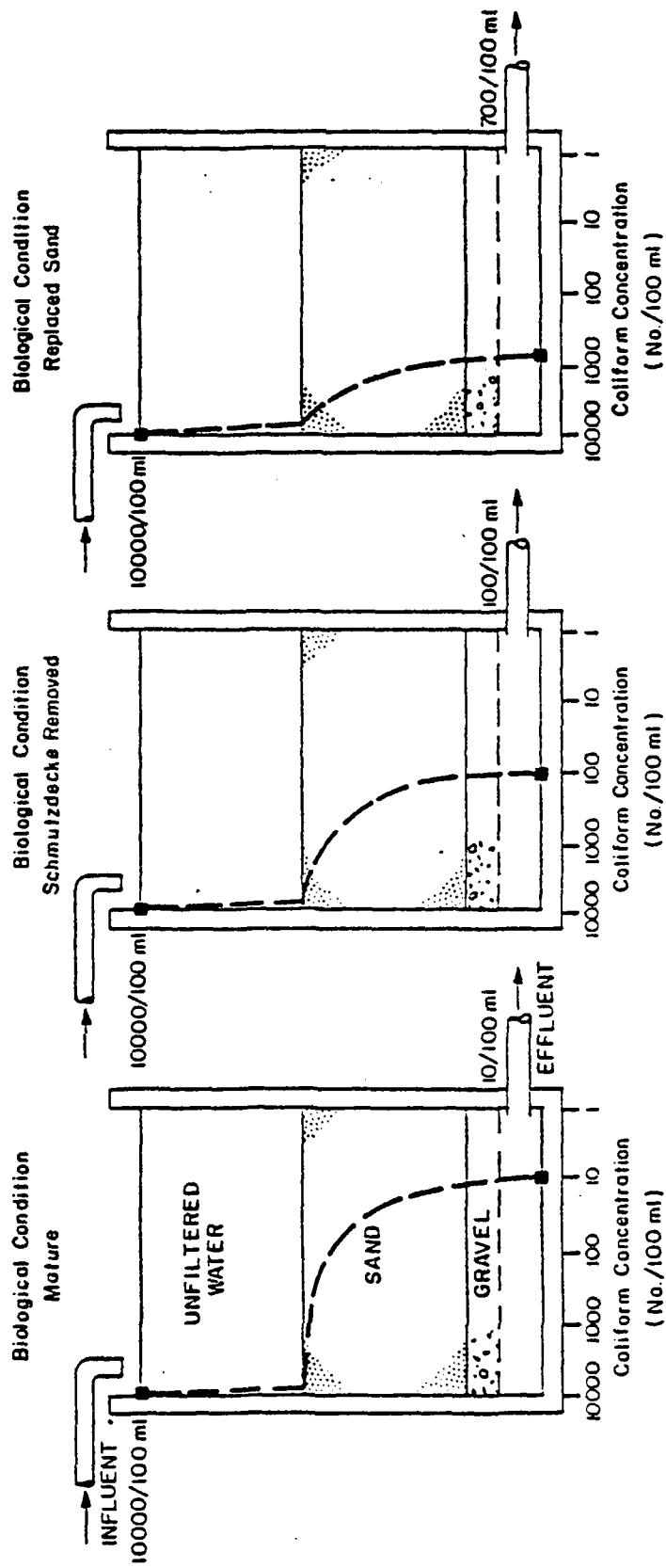

Figure 8. Effect of biological maturity within the filtration zones on slow sand filtration performance. The points shown represent experimental results in Figure 35. The dotted line is hypothetical.

5. Figure 6 shows that decreasing biological activity decreases treatment effectiveness. This was shown in Table 29 for Phase II testing.
6. Figure 7 shows that increasing the influent contaminant concentration decreases treatment effectiveness. This was shown in Figure 19 for Phase I testing.
7. Figure 8 shows that a decrease in the biological maturity within the filtration zones (i.e., different modes of operation) will decrease treatment effectiveness. This was shown in Figure 35 for Phase I testing.

These figures were constructed based on the results obtained during this research. The effluent coliform densities are based on a hypothetical influent density listed for each figure. The calculated removals are averages from testing under the conditions stated. The figures were constructed to show trends in treatment only and to summarize the findings of this research.

Figure 9 shows the interrelationships between sand bed depth, hydraulic loading rate, sand size, temperature, and nutrients. The surface shown in this figure is a hypothesized isopleth of treatment efficiency. An understanding of the composite effects demonstrated in this figure can assist in developing better slow sand filter designs and in operations. The values given in the figure for each variable indicate the range for this experimentation.

To understand the figure, consider points a, b, c and d. The treatment efficiency is the same at each of these points. There are differences, however, in the magnitudes of the variable mixes at each point. At point a, the most stressful condition, the following represents the variable mix: high hydraulic loading, low temperature, large sand and low nutrient loading. These conditions require a deep sand bed to compensate. Point d, on the other hand, is the least stressful condition and requires the least sand bed depth. As related to design and operation the response surface represents the relevant trade-offs.

Figure 9 summarizes further the findings of this research. While these findings are not new, they are important in that they are documented by experimental data. Presently, design and operating guidelines for hydraulic loading, sand size, and sand depth are based on the lore accumulated both over the decades from various investigations and from observations of practice. The works of Hazen (1913) and Huisman and Wood (1974) have defined much of the current practice.

#### APPLICATIONS FOR SLOW SAND FILTRATION

From this research, it may be asserted that slow sand filtration is an effective water treatment technology. It is passive in nature, requiring little action on the part of the operator. Because of its effectiveness and



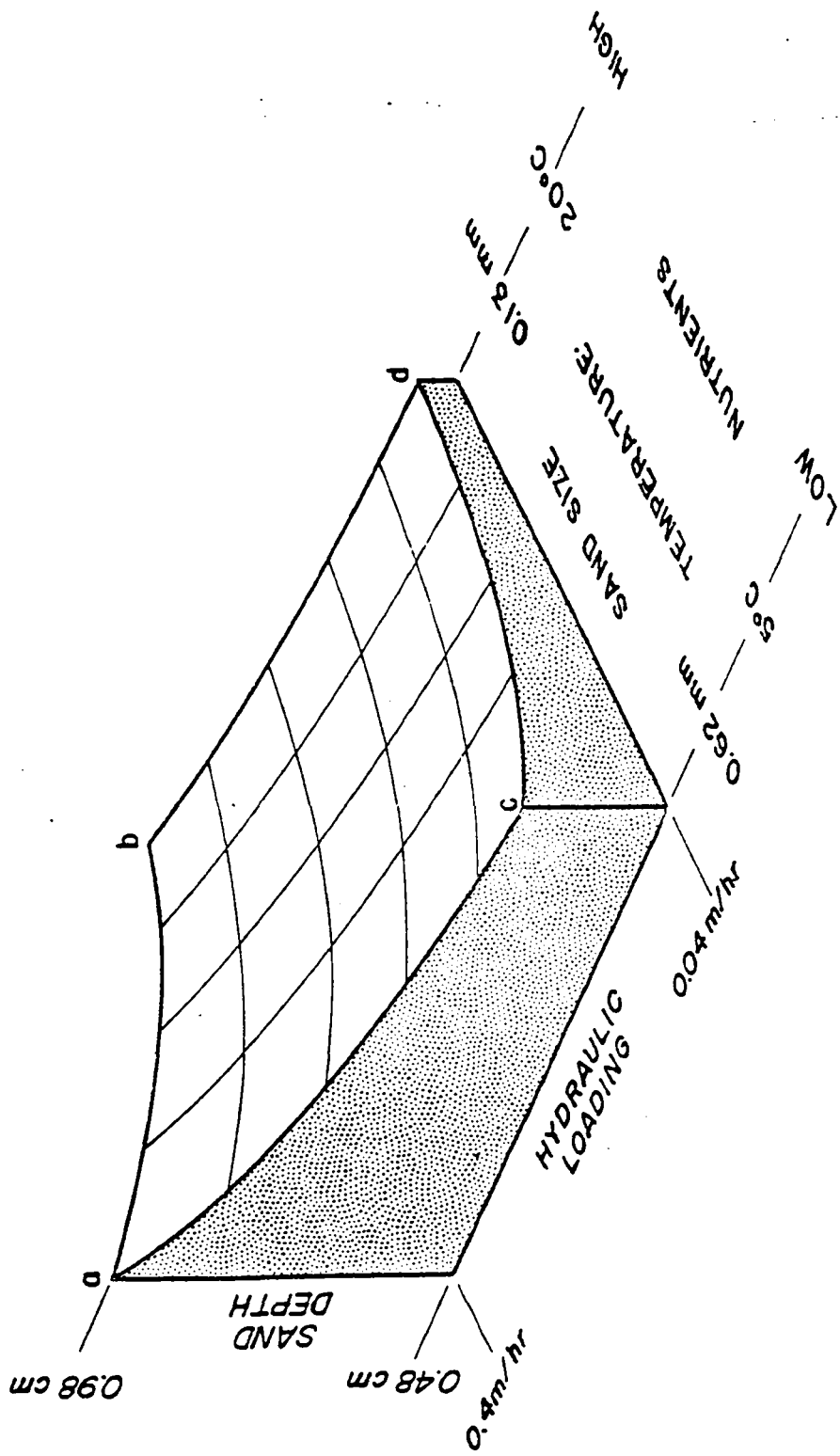

Figure 9. Trade offs of process variables for equal treatment efficiency in slow sand filtration. The response surface is an isopleth; it is a surface of equal treatment. The testing ranges for process variables are shown; they are for guidance only.

its passive nature, slow sand filtration should be especially appropriate for small communities. The selection of a water treatment process for a small or large community should be based on an economic evaluation of the technically acceptable alternatives.

## SECTION 3

### EXPERIMENTATION

The experimentation was carried out in three phases. Phase I was conducted using three one-foot diameter filters operated continuously from July 1981 to January 1983. Phase II was conducted using six one-foot diameter filters operated continuously from February 1983 to July 1983. Phase III was conducted using the same six filters operated from July 1983 to December 1983. The experimental work for the three phases was conducted at the Engineering Research Center located adjacent to Horsetooth Reservoir at the Foothills Campus of Colorado State University. A map of the reservoir and a description of the water source is included in Appendix K. The filters were supplied with raw water from Horsetooth Reservoir. Test runs were conducted at intervals during these periods to determine the efficiencies of the filters for removal of *Giardia* cysts, turbidity, total coliform bacteria, fecal coliform bacteria, standard plate count bacteria, and particles. At the same time, the experimentation assessed the effects of design, operation and influent water quality on filter performance.

A seventh filter was built and placed in operation in the chemical storage building at the Fort Collins Water Treatment Plant No. 1 on the Cache La Poudre River. Because of the proximity to the Fort Collins water supply this filter was not spiked with bacteria or *Giardia* cysts. Also the operation of the filter was terminated after about two months of operation when a pump failure occurred. Because this work was deemed of lower priority with respect to available manpower, it was decided not to continue operation.

This chapter describes the pilot plants, filters, design of experiments, and testing procedures. The pilot plants are described first since they are an integral part of the experimental design.

#### PILOT PLANTS

##### Phase I

Figure 10 is a schematic drawing of the laboratory-scale slow sand filtration pilot plant used for the Phase I testing. The pilot plant was comprised of three one-foot diameter filters and associated appurtenances. Figure 11 is a photograph of the pilot filters. The three slow sand filters were operated in parallel such that the influent water to each of the filters was the same. The filters were fed Horsetooth Reservoir water from a 1400

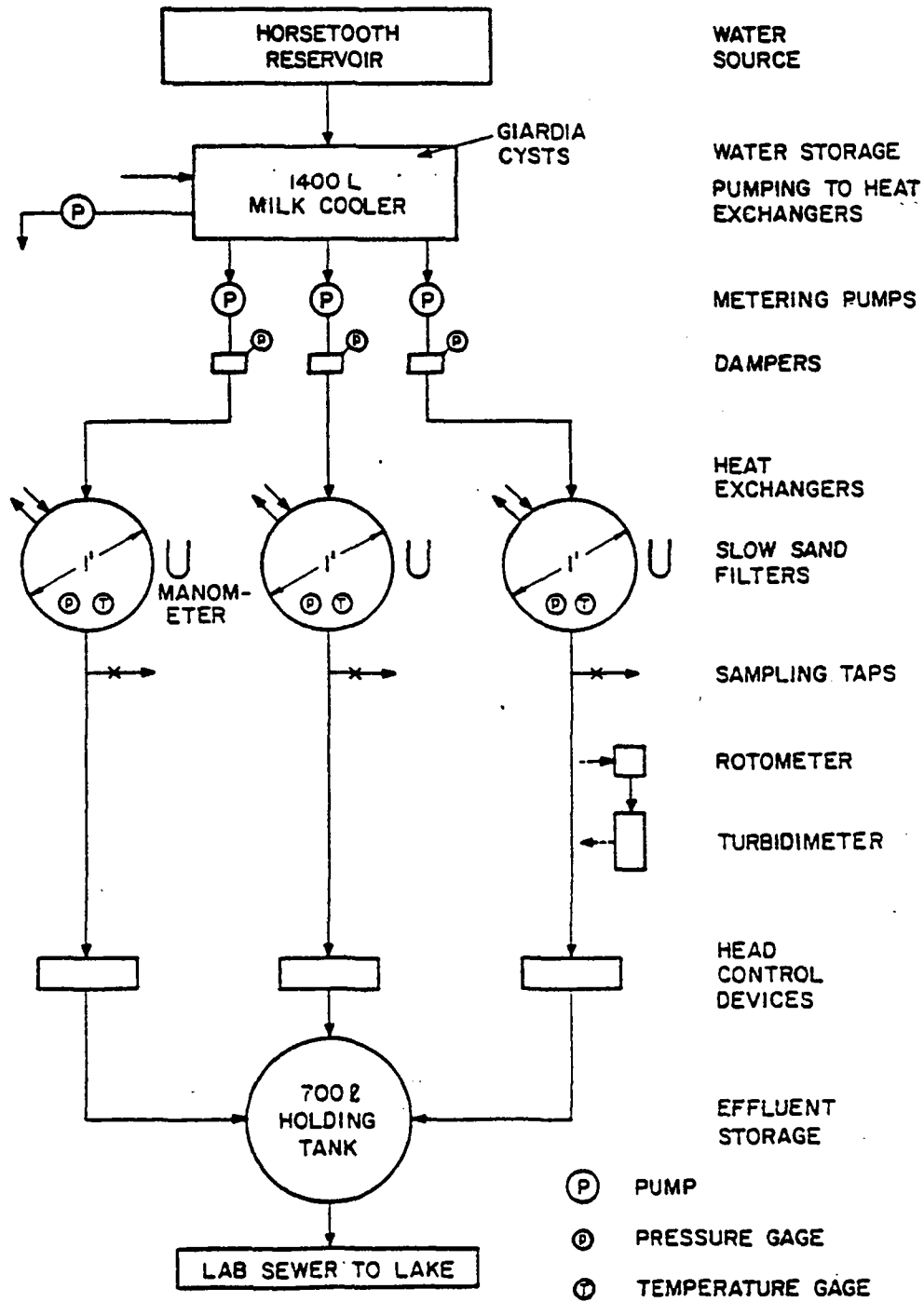

Figure 10. Flow schematic of slow sand filter pilot plant for Phase I experimentation.



Figure 11. Photograph of the slow sand pilot filter for Phase I experimentation.

liter, temperature controlled milk cooler. The milk cooler is shown in Figure 12.

Figure 13 is a cross-section drawing of one of the three pilot-scale slow sand filters used during Phase I. Each filter was constructed with 12-inch diameter, Schedule 200, PVC pipe. The filters were enclosed as pressure vessels, having blind flanges for their tops and bottoms. The top of the sand bed was just below the middle flange. This allowed access to the sand surface for cleaning purposes.

The filter columns were filled with 0.97 meters of sand obtained from Muscatine, Iowa. The effective diameter,  $d_{10}$ , of the sand, as measured by the sieve size passing 10 percent of a sample, was 0.27 mm. Figure 14 shows the results of a sieve analysis for this sand. All sieve analyses were performed with Tyler Standard Screens. The  $d_{60}$  size, the size of sieve which

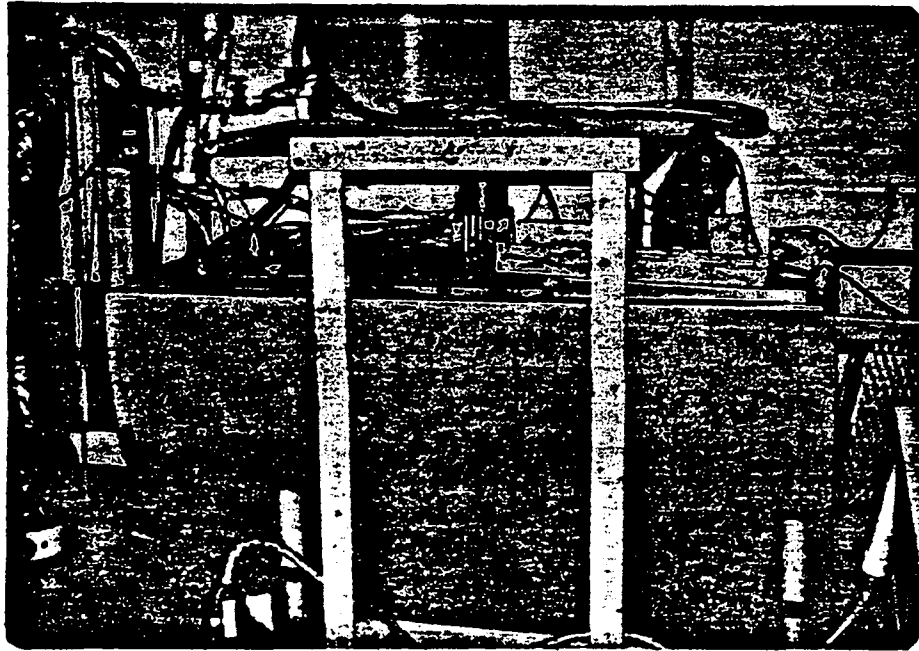

Figure 12. Temperature controlled milk cooler used as raw water storage tank for Phase I slow sand filter experimentation.

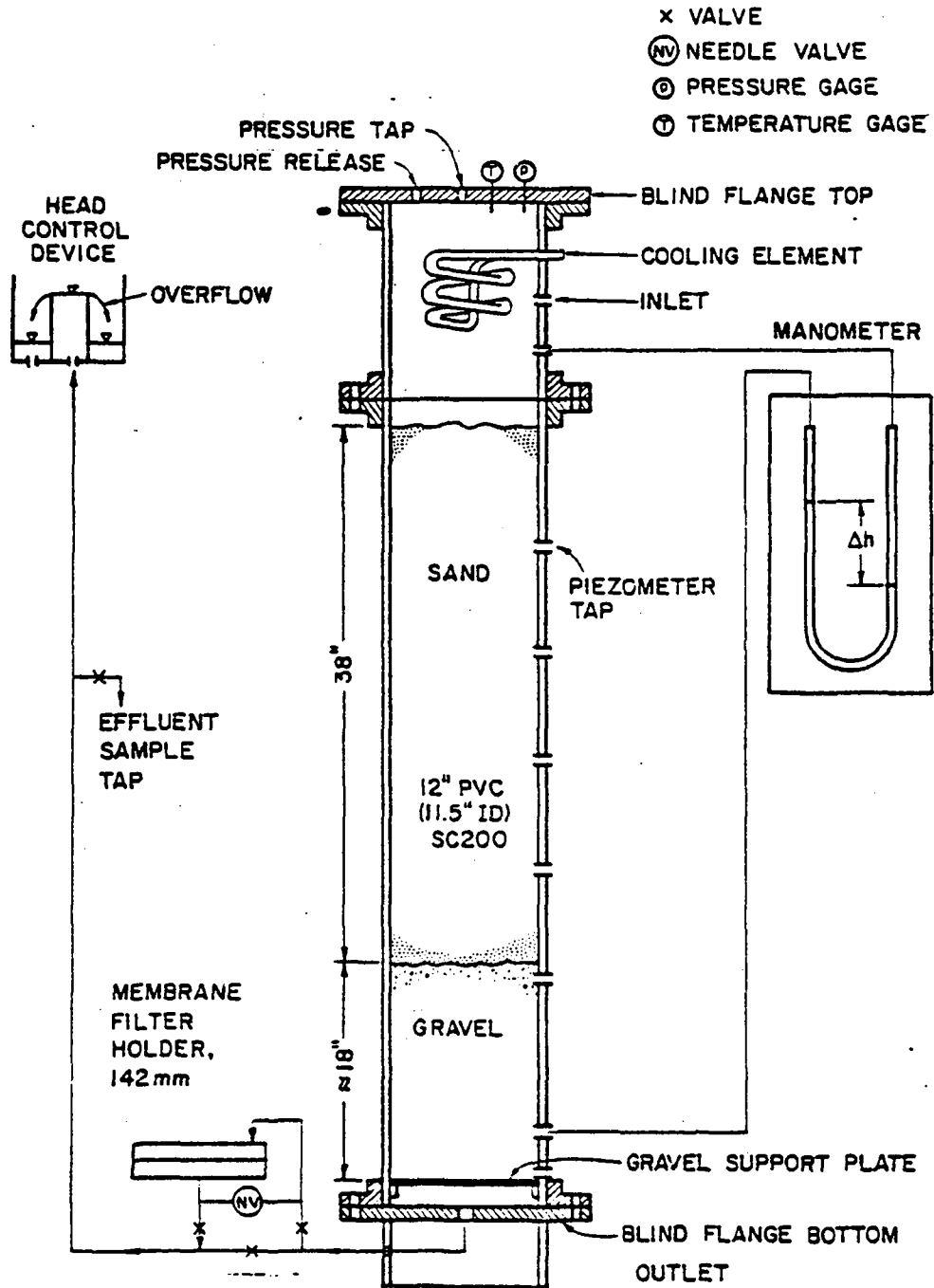

Figure 13. Pressure slow sand filter cross-section and appurtenances for Phase I experimentation.

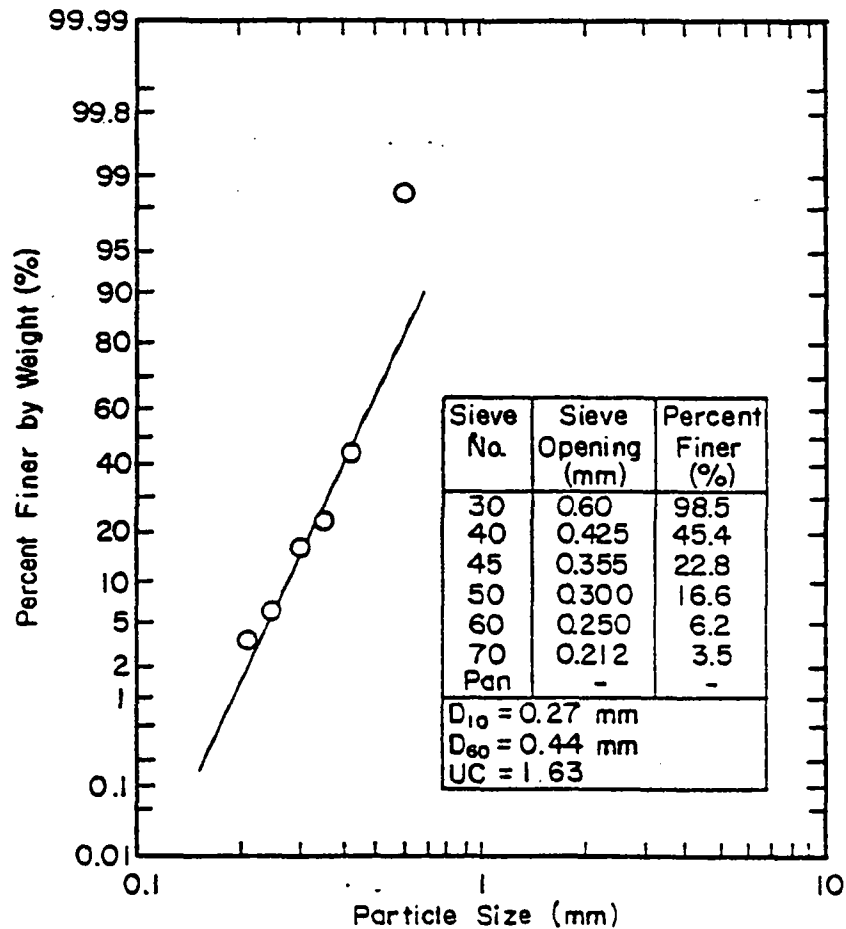

Figure 14. Sieve analysis of sand used for Phase I slow sand filtration testing.

passes 60 percent of a sample of filter media, was 0.44 mm, and the uniformity coefficient (UC) was 1.63. These values are within the recommended specifications of Huisman and Wood (1974) for slow sand filter media, which are: 1)  $0.15\text{mm} < d_{10} < 0.35\text{mm}$ , and 2) a uniformity coefficient  $< 3$ , with  $< 2$  being preferable. The sand was supported by a graded gravel underdrain of approximately 0.46 meters depth. The gravel was supported by a plate, shown in Figure 15. The media specifications for the gravel support layer are given in Table 3.

To eliminate wall effects, sand was glued to the inside of the PVC pipe from the middle flange to the support layer. The sand was the same as that used for the sand bed. This was done by painting a layer of PVC solvent glue on the inside wall and then pouring sand over the cement. The sand retained by the glue provided a surface which one would expect to eliminate virtually all wall effects. This was done for both Phase I and Phase II columns.



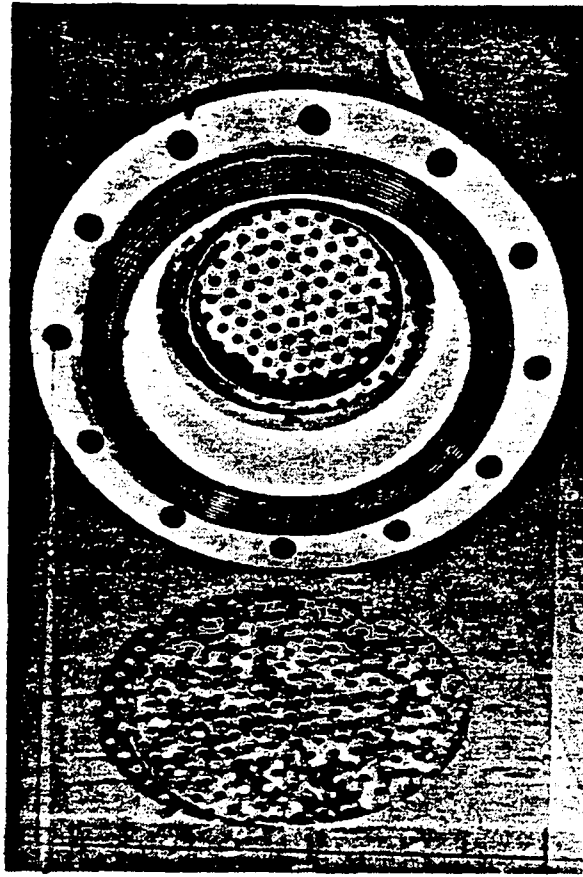

Figure 15. Gravel support plate.

Table 3. Media specifications for gravel underdrain.

Depth of Layer (cm)	Media Size
0-7	0.6-0.8 mm sand
7-15	0.8-1.2 mm torpedo sand
15-23	0.12-0.32 cm gravel
23-30	0.32-0.64 cm gravel
30-38	0.64-1.27 cm gravel
38-46	1.27-1.91 cm gravel

Table 4. List of equipment and appurtenances used in the operation of the Phase I slow sand filtration pilot plant.

Equipment	Purpose	Specifications
Tank Pumps	Influent water storage Filter feed pumps, before 2-19-82  Filter feed pumps after 2-19-82	1400 L milk cooler March Mfg., Inc. piston metering pumps 1 ea. model 210-10, 0-400 mL/min 2 ea. model 212, 0-1000 mL/min Fluid Metering, Inc., piston metering pumps 1 ea. model RP-D-1, 0-450 mL/min 2 ea. model RP-D-2, 0-1000 mL/min Gilmont, model F-1400, 10-850 mL/min 75 cm Hg
Flowmeter Manometers	Monitoring flowrate through filter Monitoring differential pressure across filters	180 cm H <sub>2</sub> O
Piezometers	Monitoring differential pressure across filters	Weiss Corp., 0-30 psig, 0-100 psig
Pressure gauges	Monitoring pressure on heads of columns and on pumps	Weston, model 4300
Temperature gauges	Monitoring temperature in filter columns	Hach ratio, Model 18900-10 HF Industries flow-through Model DRT 200
Turbidimeters	Measure turbidity	March Mfg., Inc., piston metering pumps model 210-10 and 212
Accessory Pumps	Concentrate Giardia influent sample	Teel Corp., Marine utility pump model 1P579C
Cooling Coils PVC Pipe	Drain tanks, circulation through cooling coils Temperature control in filter heads Filter housing	Copper tubing, 3/8" O.D. Schedule 200, 12" O.D., Reeves Plastic, Denver, CO
PVC Flanges	Filter housing	Van Stone flanges, Reeves Plastic, Denver, CO
Membrane Filters	Giardia cyst sampling	Nuclepore Corp., 5 µm, 142 mm diameter polycarbonate membrane
Membrane Filter holder	Membrane filter housing	Millipore Corp., P.V.C. filter holder, 142 mm diameter

In addition to the three filter columns, the pilot plant was comprised of appurtenances to facilitate control and to provide for monitoring. These are shown in Figure 10 and are listed in Table 4, which also describes the purpose and specifications of each.

#### Phase II And Phase III

Figure 16 is a schematic of the laboratory-scale slow sand filtration pilot plant use for both the Phase II and III testing. The plant was comprised of six one-foot-diameter filters and associated appurtenances. Figure 17 is a photograph of the pilot plant. The six filters were operated in parallel so that the influent water flow and the hydraulic loading rate to each of the filters were the same. Each filter, however, differed in operation by the magnitude of one process variable, using a control filter as the basis for comparison.

Figure 18 is a cross-sectional drawing of one of the six pilot-scale slow sand filters. The construction was almost identical to that described for the Phase I filters. The pipe, gravel support and flanges were identical to those used in the Phase I construction. The top, however, was left open and the filters were operated as a gravity system. Like the Phase I filters, the top of the sand bed in the gravity filters was just below the middle flange; this allowed access to the sand surface for cleaning.

Four of the Phase II filters were packed with 0.97 meters of sand having a  $D_{10}$  of 0.29 mm, a  $D_{60}$  of 0.44 mm and a UC of 1.52. The fifth filter was packed with 0.48 meters of the same sand and the sixth filter was filled with 0.97 meters of sand with a  $D_{10}$  of 0.61 mm, a  $D_{60}$  of 0.98 mm and a UC of 1.59. For the Phase III testing the sand in the second filter was replaced with sand having a  $D_{10}$  of 0.13 mm, a  $D_{60}$  of 0.20 mm and a UC of 1.60. Figures 19, 20 and 21 show the results of sieve analyses for the three types of sand used. The gravel support layer was the same as that specified in Table 3 for the Phase I filters except the bottom layer of 1/2 - 3/4" gravel was not used.

The appurtenances used to facilitate operation, control and monitoring of the six pilot sand filters are shown in Figures 16 and 17. These appurtenances are listed and the function of each is described in Table 5.

Figure 22 is a photograph of the constant head tank and orifices used to supply a constant flow to each filter. This tank was constructed with acrylic plastic. The orifices used to regulate flow to the filters and placed in the side of the constant head tank were made with 0.2 mm brass plate.

Figure 23 is a picture of the control box used to regulate the pilot plant. Tank level, water temperatures, mixing rates and pump rates were controlled with this circuitry.

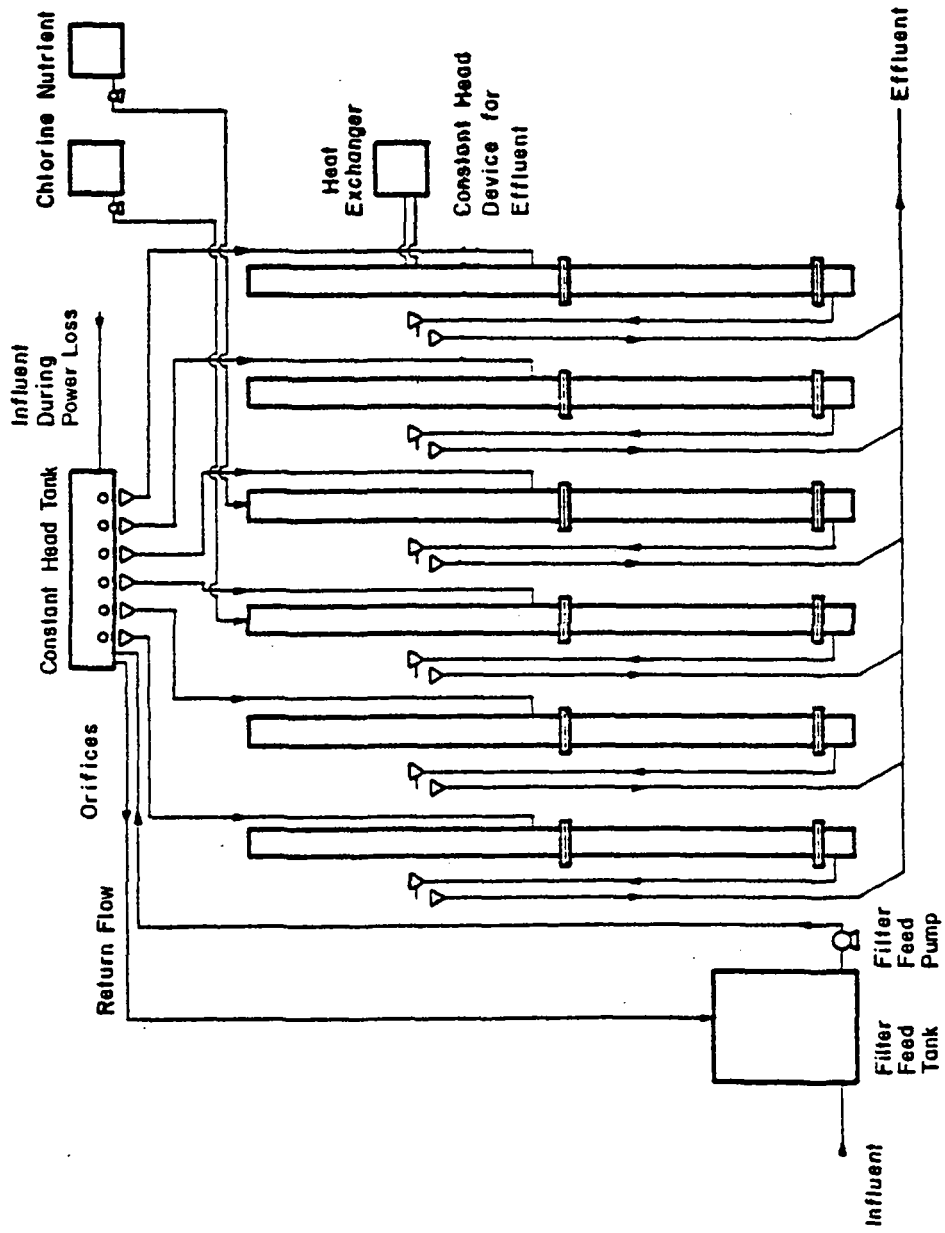

Figure 16. Flow schematic of slow sand filter pilot plant for Phase II and Phase III experiments.

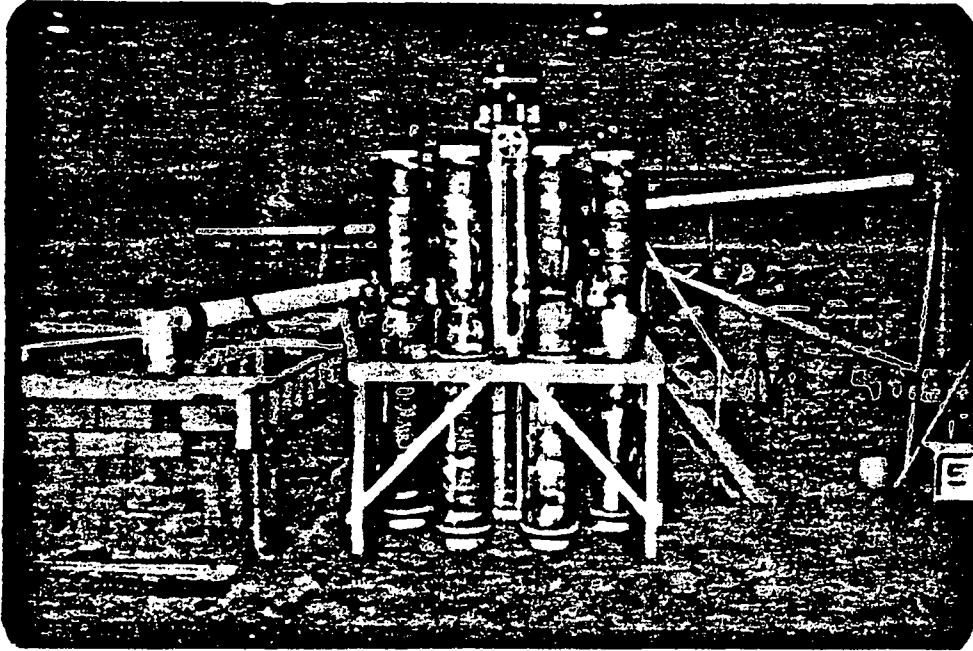

Figure 17. Photograph of Phase II and III slow sand filter pilot plant.

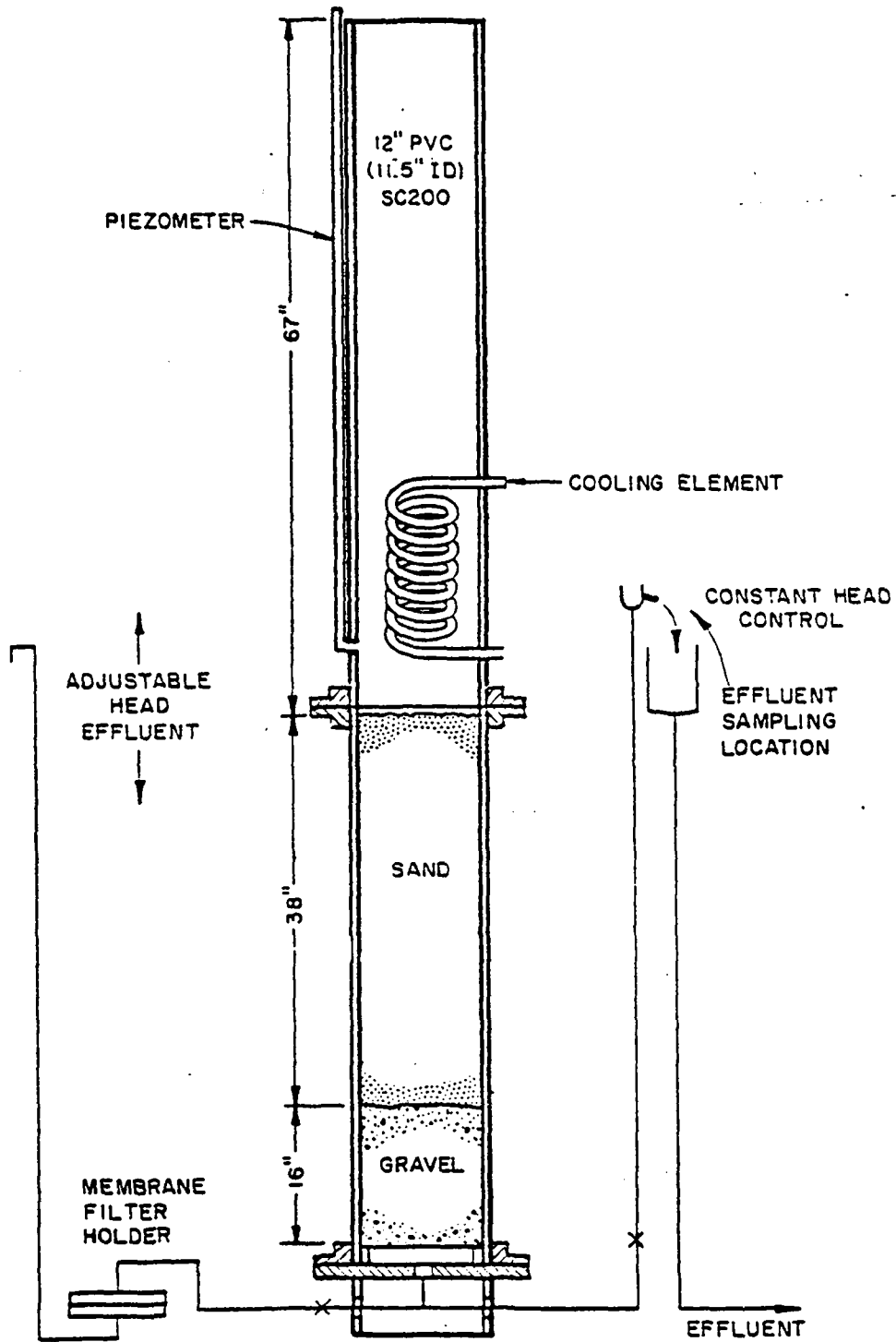

Figure 18. Gravity slow sand filter cross section and appurtenances for Phase II and Phase III experimentation.

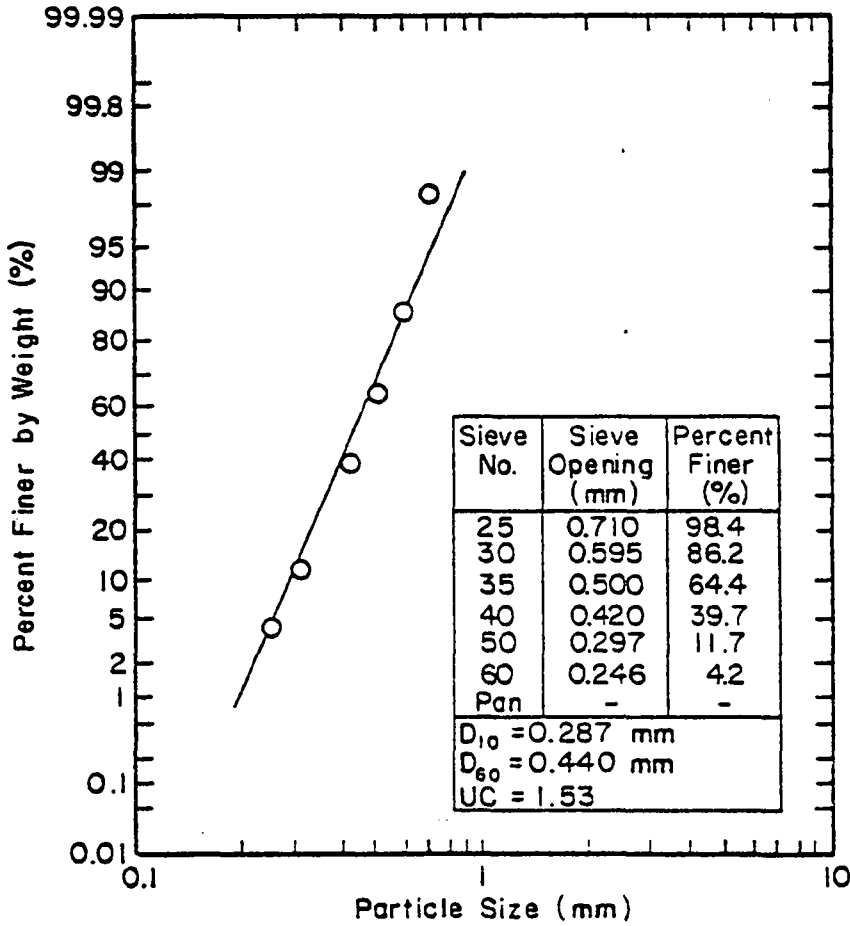

Figure 19. Sieve analysis of sand used for Phase II and III slow sand filtration testing. This is the sand used in the control filter (No. 1) and Filters 2, 3, 4 and 6.

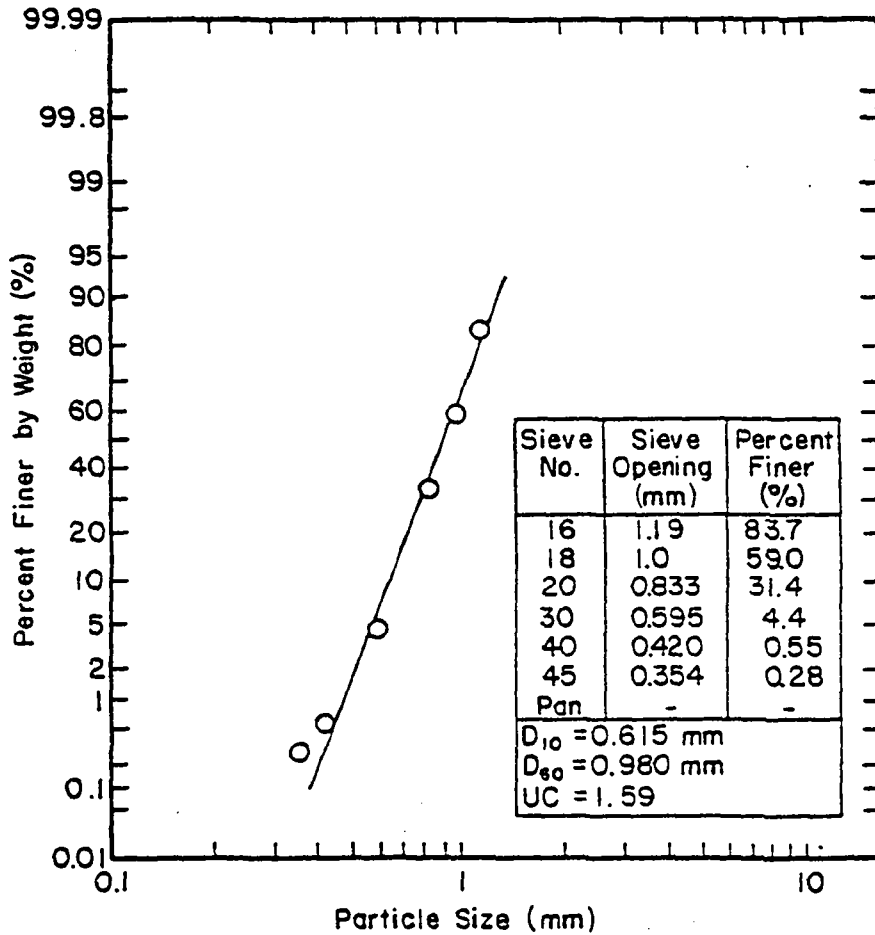

Figure 20. Sieve analysis of sand used for Phase II and III slow sand filtration testing. This is the large sand size used in Filter 5.



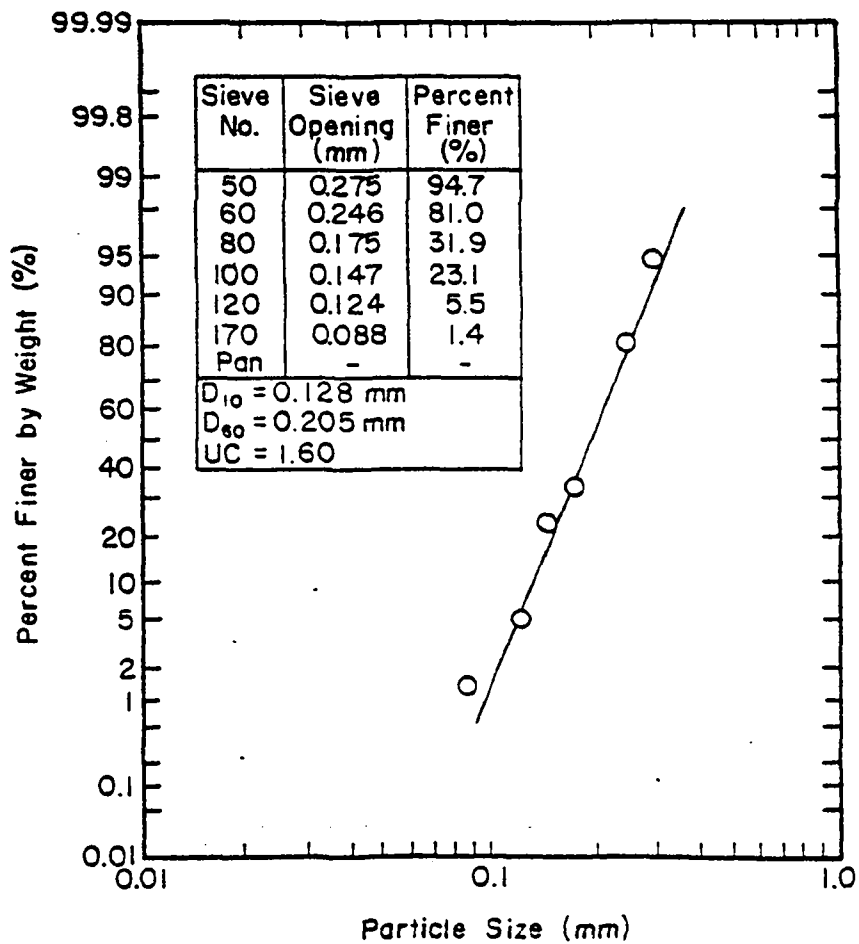

Figure 21. Sieve analysis of sand used for Phase III slow sand filtration testing. This is the smallest sand used. It was placed in Filter 3.

Table 5. List of equipment and appurtenances used for the Phase II and III slow sand filtration pilot plant.

Equipment	Purpose	Specifications
Tank	Influent water storage	1200 L polyethylene tank, Industrial plastics,
Piezometers	Chlorine storage Nutrient storage Measure head loss across filters	20 L pyrex glass bottle, covered with aluminum foil. 20 L pyrex glass bottle 120 cm H <sub>2</sub> O
Pumps	Pump raw water from feed tank to constant head tank. Pump chlorine	Fluid metering Inc., 0-1000 mL/min piston metering pump Ecoodyne, 0-7 gal/day, Mec-O-Matic diaphragm pump.
Refrigeration Unit	Pump nutrient	Master Flex, Head K-7014 0-126 mL/min
Cooling Coils	Cool filters for low temperature operation Temperature control in filter heads	Neslab HX-500, Refrigerated Recircular tray Heat Exchanger, 1°C to 35°C, 53,500 BTU. Copper tubing 3/8" O.D.
PVC Pipe	Filter housing	Schedule 200, 12" O.D. PVC
PVC Flanges	Filter housing	Van-Stone flanges 12" PVC
Membrane Filters	Giardia cyst sampling	Nuclepore Corp., 5 µm, 142 mm diameter polycarbonate membrane
Membrane Filter Holders	Membrane filter housing 142 mm diameter	Millipore Corp., PVC filter holder

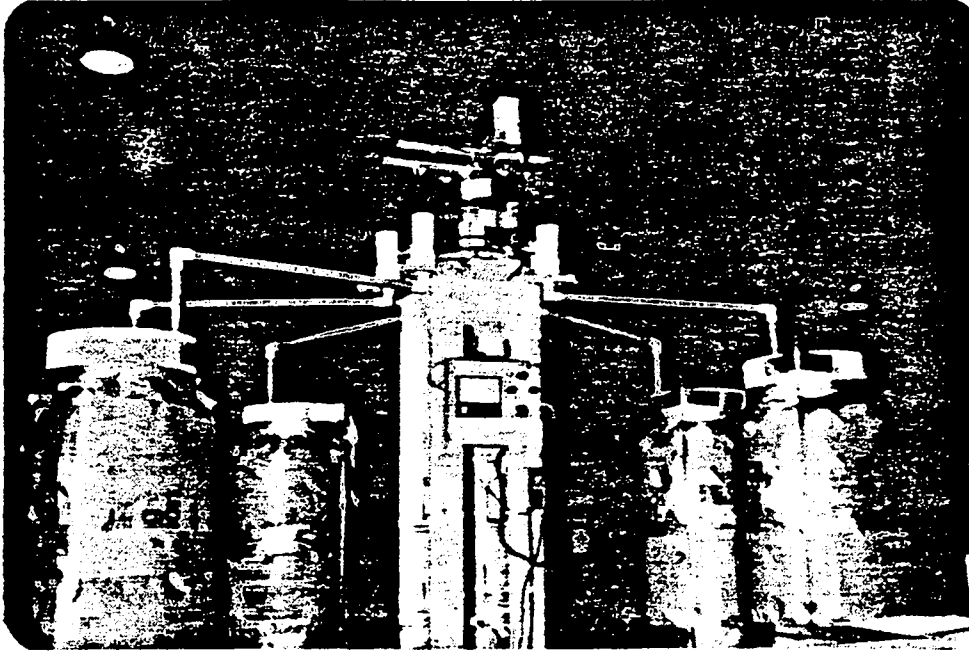

Figure 22. Constant head tank used for the Phase II and III slow sand filter pilot plant.

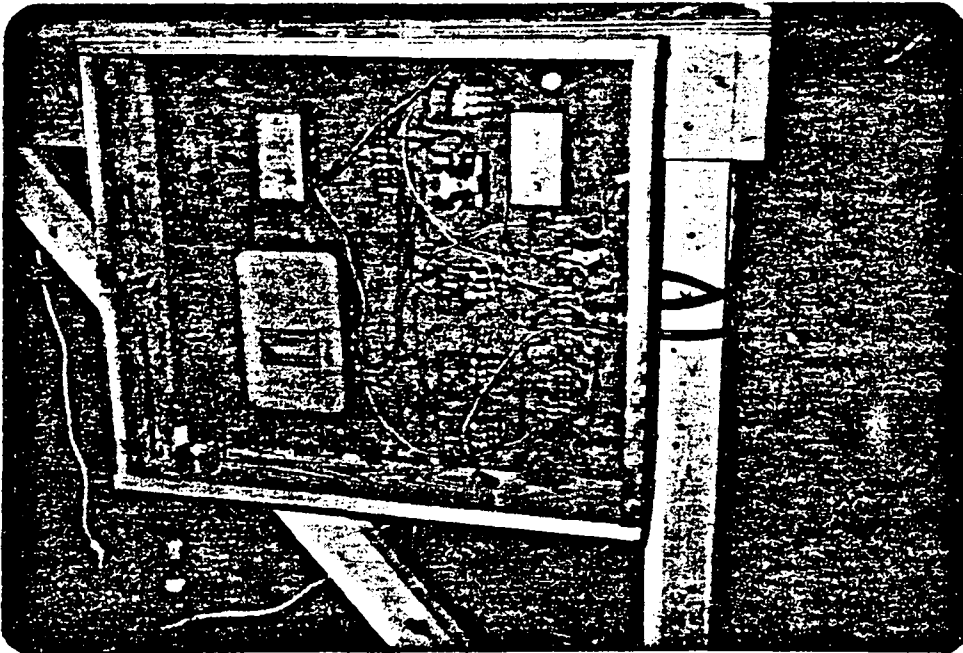

Figure 23. Electrical control panel used for the Phase II and III slow sand filter pilot plant.

## EXPERIMENTATION PROGRAM

The experimental program, which included Phase I, Phase II, and Phase III testing, was designed to evaluate the effectiveness of slow sand filtration for various design, operating, and water conditions. The Phase I experiments were conducted to determine the response of slow sand filters to several operating variables such as hydraulic loading rate, presence of schmutzdecke and biological development of sand bed. The Phase II and III experimentation examined the roles of biological activity, sand bed depth, temperature and sand size on treatment mechanisms and performance.

### Design of Experiments

The Phase I experimental program was established to determine the efficiency of slow sand filtration for removal of *Giardia* cysts as affected by hydraulic loading rate. At the same time removals of total coliform bacteria, fecal coliform bacteria, standard plate count bacteria, particles, and turbidity were investigated. As the Phase I results were evaluated, however, it became apparent that the biopopulation within the sand bed had a great deal to do with filter efficiency, and that a great deal more could be learned about this and other process variables by setting up additional experiments. The approach was to use the results of each phase of tests to direct the design of subsequent tests. Thus Phase I was the basis for designing a subsequent set of experiments, which was Phase II. The results of Phase II tests were the basis for the Phase III experimental design.

The experimental design followed the empirical approach of observing the outputs of a physical model while subjecting the model to changes in process variables. The physical model was the slow sand filter pilot plant and changes were imposed on the process variables affecting the efficiency of the filtration process.

Table 6, Table 7 and Table 8 summarize the dependent and independent (process) variables incorporated in the design of the Phase I, II and III experiments, respectively. The range for each of the independent variables, i.e., the testing range, is also given in the tables.

Tables 9, 10 and 11 show in matrix form the independent variables used during the Phase I, II and III testing, respectively. These matrices map the experimental program. The dependent variable responses to each of the tests indicated in the matrices provides a set of functional responses to the range of testing imposed.

### Phases of Experimentation

For the Phase I experiments, Table 6 shows the independent variables examined and the range of testing for each, while Table 9 outlines the overall experimentation program. The three hydraulic loading rates, 0.04, 0.12, and 0.40 m/hr, were imposed, respectively, on three filters run side by side over the 18 month period. They were fed Horsetooth Reservoir water, and all conditions were maintained the same for the three filters, except

Table 6. Dependent and independent variables for Phase I testing.

Dependent Variable	Independent Variable	Variable Range
Removal of <u>Giardia</u> cyst	Hydraulic loading rate	0.04, 0.12, 0.40 m/hr
Removal of coliform	Temperature	5°C - 15C (temperature was lowered to 5°C only for selected test runs)
Removal standard plate count bacteria	Influent <u>Giardia</u> cyst concentration	50-5000 cysts/liter
Removal of turbidity	Influent total coliform bacteria concentration	0-290,000 coliforms/100 mL
Removal of particles	Surface condition of filter	Established schmutzdecke or schmutzdecke removed
	Age of filter sand	Newly installed sand to filters in continuous operation for 18 months

Table 7. Dependent and independent variables for Phase II testing.

Dependent Variable	Independent Variable	Variable Range
Removal of <i>Giardia</i> cysts	Temperature	5°C, 17°C
Removal of coliform bacteria	Filter bed sand depth	48 cm, 97 cm
Removal standard plate count bacteria	Sand size	0.287 mm, 0.615 mm
Removal of turbidity	Nutrient loading	Lake water and lake water with injection of nutrients. The DO reduction was <1 to 5mg/L, respectively.
	Influent standard plate count bacteria concentration	10 <sup>0</sup> /mL - 10 <sup>5</sup> /mL
	Surface condition of filters	Established <sup>1/</sup> schmutzdecke or schmutzdecke removed
	Age of filter sand	Newly installed sand to filters in continuous operation for 10 months

<sup>1/</sup> An "established" schmutzdecke is not defined precisely. It could be defined by selecting a criterion using for example, thickness, hydraulic headloss, or percent removal of coliform bacteria. In this work we have used age, with a criterion of about 15 days. After 15 days of operation, nominally, a schmutzdecke seems to be in place, or measured by the other parameters. It takes only a few days, however, for the schmutzdecke to become established again after scraping, vis a vis with a new sand bed.

Table 8. Dependent and independent variables for Phase III testing.

Dependent Variable	Independent Variable	Variable Range
Removal of <i>Giardia</i> cyst	Temperature	2°C, 17°C
Removal of coliform bacteria	Filter bed sand depth	0.97m
Removal standard plate count bacteria	Sand size	0.13mm, 0.287mm, 0.615mm
Removal of turbidity	Influent standard plate count bacteria concentration	10 <sup>0</sup> /mL, 10 <sup>6</sup> /mL
	Filters surface condition	Established schmutzdecke, or diatomaceous earth coating, or schmutzdecke removed
	Age of filter sand	Filters in continuous operation for 10 months

Table 9. Phase I experimentation program for slow sand filtration.

Filter Condition	Temp. (°C)	Influent Giardia Concentration (cysts/liter)	Hydraulic Loading Rate		
			1 MGAD 0.04 m/h	3 MGAD 0.12 m/h	10 MGAD 0.40 m/h
Established Filter <sup>1/</sup>	5	50	x	x	x
		500	x	x	x
	15	50	x	x	x
		500	x	x	x
		1000	x <sup>5/</sup>	x <sup>5/</sup>	x <sup>5/</sup>
		2000			x
		3700		x	
		5000	x	x	x
Schmutzdecke Removed <sup>2/</sup>	5	50	x	x	x
		500	x	x	x
	15	50	x	x	x
		1500	x	x	x
Schmutzdecke Removed & Shocked <sup>3/</sup>	15	2000	x	x	x
Resanded <sup>4/</sup>	15	3700		x	
New Sand and Gravel Support	15	2000			x

- <sup>1/</sup> Established filter means that there is a developed and stable biopopulation within the filter and that there is an established schmutzdecke at least 2 weeks old on the surface of the sand.
- <sup>2/</sup> Schmutzdecke removed means that the schmutzdecke has been scraped off just prior to the start of the test run.
- <sup>3/</sup> The schmutzdecke was scraped and an attempt was made to simulate practice by disturbing the sand surface. Disturbing the sand surface was done by mixing the top 15 cm and beating on the sand surface and sides of the filter in an attempt to simulate equipment and men moving on the surface. The column was refilled with water from the bottom after 48 hours.
- <sup>4/</sup> A resanded filter is one that has the sand column replaced but the gravel layers remain intact.
- <sup>5/</sup> Three test runs were performed for these conditions.



Table 10. Phase II experimentation program for slow sand filtration.

Filter No.	Operating Conditions <sup>1/</sup>	Filter Condition		
		New Sand	Established Biological Population	Schmutzdecke Removed
1	Control <sup>2/</sup>	x	x	x
2	48 cm sand depth	x	x	x
3	Chlorinated, i.e., Physical removal <sup>3/</sup>	x		x
4	Nutrients added, i.e., Enhanced biological activity <sup>4/</sup>	x	x	x
5	0.615 mm sand size 5°C	x	x	x
6	5°C	x	x	x

<sup>1/</sup> All filters were operated at the same hydraulic loading rate of 0.12 m/hr. All were fed the same raw water from Horsetooth Reservoir, which was first temperature equilibrated to 17°C. The filters operated at 5°C were temperature equilibrated in the head water above the sand bed.

<sup>2/</sup> Filter No. 1, the control filter, was operated at 17°C with a sand bed of 0.97 m, an effective sand size of 0.278 mm, and with no nutrient addition, i.e., <5 mg/L COD.

<sup>3/</sup> The physical removal was maintained by keeping a 5 mg/L chlorine residual in the filter when bacteria tests were not being performed; dechlorination with sodium thiosulfate was performed prior to bacteria testing.

<sup>4/</sup> The biological activity was enhanced by adding nutrients in the form of sterile, synthetic sewage, prepared as outlined in Appendix P.

Table 11. Phase III experimental program for slow sand filtration.

Filter No.	Operating Conditions Other than Control <sup>1/</sup>	Filter Condition		
		New Sand	Established Biological Population	Schmutzdecke Removed
1	Control <sup>1/</sup>		x	
2	Diatomaceous earth coated surface		x	
3	0.128 mm sand size	x	x	
4	Nutrient addition stopped		x	
5	0.615 mm sand size, warmed from 5°C		x	
6	2°C		x	

<sup>1/</sup>The control filter (No. 1) was operated at 17°C with a sand bed of 0.97m, an effective sand size of 0.278mm, and with no nutrient addition, i.e., <5 mg/L COD.

hydraulic loading rate. Test runs were conducted by spiking the milk cooler with *Giardia* cysts or raw sewage. Temperature was maintained at 15°C except several test runs were conducted at 5°C (for the duration of the test run only). During initial *Giardia* test runs temperature was maintained at 20°C, but *Giardia* cysts could not be recovered from the milk cooler when this temperature was used so all further testing was conducted at 15°C. A range of concentrations was used in the testing for both *Giardia* cysts and total coliform bacteria. This was done by controlling the dosage to the milk cooler. The role of the schmutzdecke was ascertained by conducting test runs before and after scraping the sand surface to remove it. The influence of the "age" or "biological maturity" of the filter sand was determined by merely noting the weeks elapsed since the start-up of the filters, and the corresponding removal efficiencies.

The Phase II program of experimentation, outlined in Tables 7 and 10, was inspired by the results obtained during Phase I. The Phase I results gave a basis for determining the influences on removal efficiencies due to hydraulic loading rate, concentration of organisms, the schmutzdecke, and biological maturity of the sand bed. Since the 5°C temperature was imposed only during selected test runs, the role of temperature was not clear. But the main impetus from Phase I was to learn more about the role of the biopopulation within the sand bed. To do this three filters were to be operated side by side. The first was to be a "control", i.e. operated using raw water from Horsetooth Reservoir, maintained at 17°C. Another was to be operated the same, but a nutrient solution, prepared as outlined in Appendix P, was metered to the raw water fed to the filter. The idea was to ascertain whether the development of biological maturity could be

accelerated by providing nutrients. At the same time the experiment would provide further evidence on whether the internal biopopulation within the sand bed has an important role in improving removal efficiency of the slow sand filtration process. The measure of efficiency used as a means to gage the degree of biological maturity of the sand bed was percent removal of total coliform bacteria, which were added to the filters as pure cultures. The pure cultures were used, vis a vis sewage, to minimize fouling due to the testing itself. In order to further develop the point related to the role of the internal biopopulation, the third filter was chlorinated continuously. The chlorine was purged from the system before test runs. While the role of the internal biopopulation was the principle interest in Phase II, the economy of scale permitted operation of three additional filters to examine the effects of sand bed depth, effective sand size, and temperature. Two filters were operated continuously at 5°C.

After examining results from Phase II, some questions were pursued further. The experimentation program for pursuing these questions was called Phase III, and the outline of experimentation is given in Tables 8 and 11. To ascertain the role of straining as a mechanism in slow sand filtration, a thin layer of diatomaceous earth (Marville C-545 R) was added to the surface of Filter No. 2. Then another point was needed to determine the influence of effective sand size so Filter No. 3 was repacked with sand having 0.128 mm effective size. The nutrient addition was ceased for Filter No. 4, and Filter No. 6 was operated at 2°C instead of 5°C.

#### Test Run

A "test run" is defined as the process of daily spiking the filter source water with *Giardia* cysts and or bacteria over a period of one to two weeks while sampling effluent concentrations of these organisms over the same time period. The daily spiking was done by adding an aliquot of cysts from a refrigerated stock suspension, whose concentration had been measured after preparation. Data were obtained also, at times other than test runs, for removals of turbidity, coliform bacteria and standard plate count bacteria. These data augmented data obtained during test runs.

#### Testing Period

The testing procedures were basically the same for *Giardia* and bacteria test runs. A test run would last from a few days to two weeks. During this period there was a daily routine of sampling and measurements. The following is the testing protocol conducted daily during a test run. This protocol was followed for the Phase I, II and III testing.

#### SAMPLING PROTOCOL FOR TEST RUN

1. Fill the 24 hour filter feed tank with a known volume of water from Horsetooth Reservoir.

2. Add a known concentration of Giardia cysts from a stock suspension and/or bacteria to the filter feed tank. These counts are designated as "added" cysts.
3. Collect a grab sample from the filter feed tank for coliform bacteria, standard plate count bacteria, turbidity and particles. Not all of these parameters were measured for every test run.
4. Collect a grab sample from the effluents of the slow sand filters for coliform, standard plate count bacteria, turbidity and particles as required for the test run.

(Procedures 5, 6, 8, and 9 are required only for Giardia testing.)

5. Start effluent Giardia sample collection by connecting membrane filters to the effluents of the slow sand filters.
6. Collect influent Giardia cyst sample by filtering 2 to 10 liters of water from the filter feed tank through a membrane filter. The counts obtained were designated as "detected".
7. Record operating data from slow sand filters:
  1. Temperature
  2. Head loss
  3. Flow
8. Remove membrane filters from slow sand filters after a minimum of 4 hours, preferably after 6 hours, or before 10 psi pressure is built up across the membrane filters.
9. Prepare samples for analysis.
10. Check all pumps and equipment to assure the pilot plant is operating correctly.

In calculating percent removals, the influent samples were compared with the effluent samples obtained 24 hours later. This 24 hour time displacement between influent and effluent comparisons allowed for several volume displacements in the filters. Since the feed water to the filters was constant for 24 hours, a more accurate comparison was made by separating the influent and effluent samples by 24 hours. Using this procedure, the feed tank was sampled on the first day of a test run and the filter effluents were sampled on the last day of a test run.

#### Testing Procedures

##### Giardia Testing and Cyst Procurement--

A basic premise for this study was that viable Giardia lamblia cysts were to be used. This dictated the use of fresh, unpreserved cysts.

Previous research had been performed with preserved, formalin fixed, and or "cleaned" cysts. Such processing is believed to cause changes in the morphology of the cysts and possibly in their behavior during filtration. Also, the viability of such cysts is questionable. Appendix K, Cyst Preparation, Use and Analysis, contains a brief discussion on cyst behavior after formalin fixing and cyst cleaning. Also it has descriptions and evaluations of the Giardia analysis techniques.

The Giardia cysts used for this study were obtained from dog feces. These cysts are believed to be Giardia lamblia species, as discussed by Davies et al. (1983) and by Hewlett et al. (1982). Table 12 shows the sources where cysts were collected.

Table 12. Sources used in obtaining dog fecal samples containing Giardia lamblia cysts.

Source	Conditions
1. Collaborative Radiological Health Laboratory (CHRL)	Approximately 200 dogs About 10 to 30 dogs are infected at any one time.
2. Humane Society for Larimer County	25-50 dogs, strays, runaways
3. Veterinary Teaching Hospital	Random samples brought into Parasite Diagnostic Laboratory
4. Oncology-Veterinary Teaching Hospital	12 dog pens, 10-30 dogs

Giardia cyst procurement, supervised by Dr. C.P. Hibler of the Colorado State University Pathology Department, was accomplished by the following steps:

- 1) Collect a fecal sample from a dog suspected of having giardiasis.
- 2) Analyze a portion of the sample by the Zinc flotation procedure to ascertain whether Giardia cysts were present.
- 3) Weigh the sample and add an equal weight of cool distilled water, if cysts are present.
- 4) Mix the sample to break apart aggregates.
- 5) Filter the sample through cheese cloth if the sample contained an excessive quantity of organic matter.
- 6) Determine the cyst concentration in the concentrate by the "Stoll dilution" technique, described in Appendix K.
- 7) Store the sample under refrigeration until use.

The cyst concentrate was used within two weeks of collection even though cyst counts have been observed to remaining constant in stored concentrates for two months or longer.

#### Giardia Sampling—

The cyst sampling technique used for these experiments was patterned after the procedure developed by Luchtel et al. (1980). First the sample was concentrated by passing it through a 5  $\mu\text{m}$  pore size polycarbonate membrane filter. Then the membrane filter was washed with approximately 200 mL of cool distilled water. The wash water was then stored under refrigeration until analysis. This was done for both the influent and effluent samples. Figure 24 shows the membrane filter apparatus.

The 5  $\mu\text{m}$  pore size polycarbonate membrane filter was selected as the method of sample concentration when it was determined that the cysts would not pass through the filter and that the cysts appeared to wash almost completely off the filter, (see Appendix K). Also of interest is the fact that in one of the samples the 142 diameter membrane filter could concentrated 2670 liters of slow sand filter effluent.

The steps in obtaining a sample from the influent feed tank containing a known concentration of *Giardia* cysts (described previous page as step 6) are described in the enumeration following. The "known" concentration designation was based upon calculation of the tank contents based upon measurement of cysts "added" from the refrigerated stock solution. The procedure below describes how the tank contents were sampled to obtain a "detecte" cyst concentration in the tank, using the same procedure as use for the effluent sampling. The "detected" cyst concentration in the tank was the basis for percent removal calculations. The steps were:

#### GIARDIA SAMPLING - INFLUENT TANK

1. Wash membrane filter holder with hot, soapy water. Rinse with cold tap water.
2. Place membrane on stainless steel support plate, as shown in Figure 25. Screw top securely into place.
3. Fill membrane filter holder chamber with cold tap water through the influent and effluent hose.
4. Mix influent tank thoroughly before sampling. Circulate water through pump sample for at least five minutes to assure a representative sample.
5. Attach membrane filter to pump, making sure all air is bled from the system.
6. Collect the effluent flow from the sample filter in a calibrated bucket. Figure 26 shows this process.

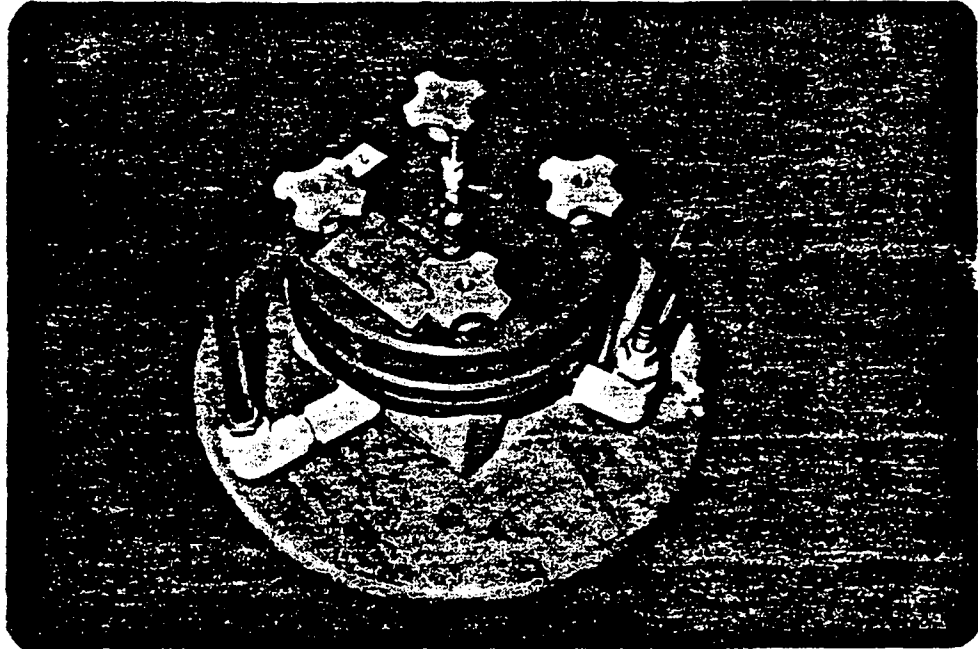

Figure 24. Assembled 142 mm diameter filter holder used in testing for Giardia cysts.



Figure 25. The 5  $\mu$ m pore size 142 mm diameter polycarbonate filter used for sampling Giardia cysts.

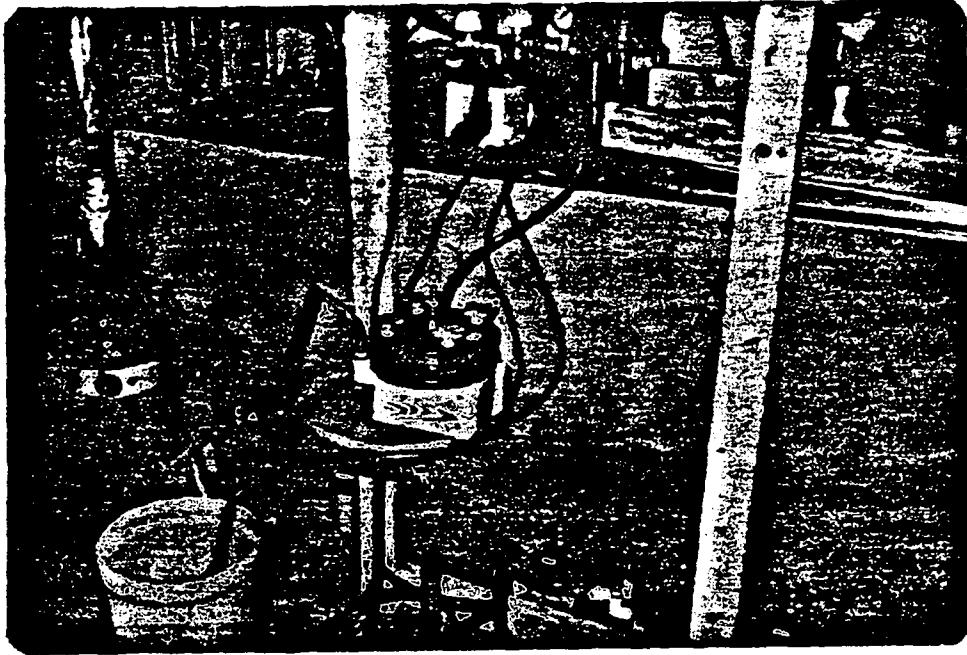

Figure 26. Membrane filter and pump setup used to concentrate an influent Giardia cyst sample.

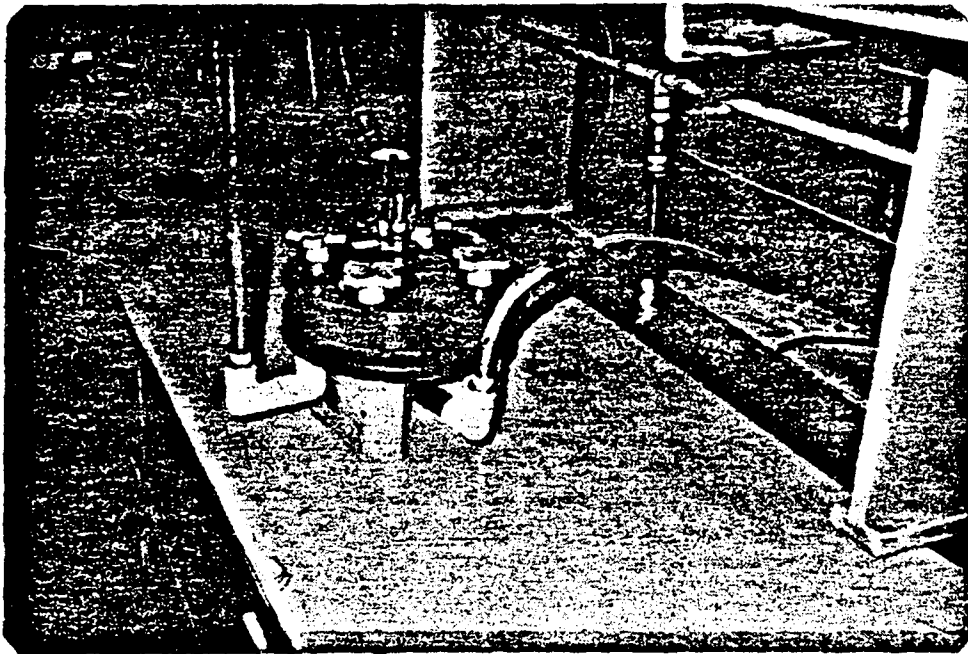

Figure 27. Aspirator connected to effluent piping of membrane filter holder to draw off excess water.



7. Filter in this manner until a minimum of two liters has been concentrated. The maximum volume filtered is limited by a pressure of 10 psi on the pump.
8. After sampling is complete, turn off pump and unhook filter from pump. Record volume concentrated in log book.

(The Giardia cysts must now be washed from the membrane filter.)

9. Attach the effluent tube of the membrane filter holder to an aspirator as shown in Figure 27 to remove the excess water in the chamber.
10. Open membrane filter holder carefully so that the membrane remains on the bottom half of the apparatus.
11. Wash top of filter holder with distilled water from a spray jet bottle, into a clean pyrex dish, as shown in Figure 28.
12. Lift stainless steel support plate with membrane from bottom half of filter holder and thoroughly spray wash into pyrex dish. Discard membrane after washing. Figure 29 shows the membrane filter being washed.
13. Wash bottom of membrane filter holder into dish. Especially spray the inlet portal. Figure 30 shows this procedure.
14. Pour contents from pyrex dish into a cooled mason jar labeled with the sample number, as shown in Figure 31. Spray off dish into jar to assure complete transfer of sample. Refrigerate the sample immediately.
15. Wash membrane filter holder with hot, soapy water to eliminate contamination. This is shown in Figure 32.

A similar procedure is used for obtaining samples from the filter effluents. The following steps describe this method. Figure 33 depicts by three schematic drawings the three alternate flow paths during different steps of filter effluent sampling during Phase I testing. Figure 29 depicts the membrane filter path used during Phase II and III testing.

#### GIARDIA SAMPLING - FILTER EFFLUENTS

1. Wash membrane filter holder with hot, soapy water. Rinse with cold tap water.
2. Place membrane on stainless steel support plate, as shown in Figure 3-16. Screw top securely into place.
3. Fill membrane filter holder chamber with cold tap water through the influent and effluent hose.



Figure 28. Spraying the top of the membrane filter holder with distilled water.



Figure 29. Spraying the membrane support and the membrane filter with distilled water.

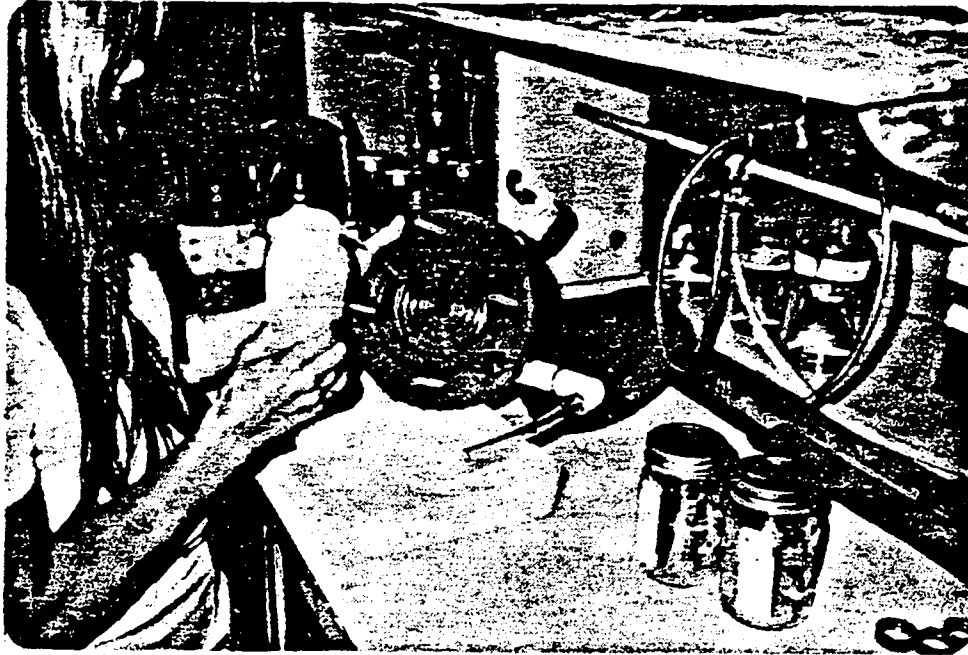

Figure 30. Spraying the bottom of the membrane filter holder with distilled water.



Figure 31. Emptying the Giardia cyst collection dish into sample jar.

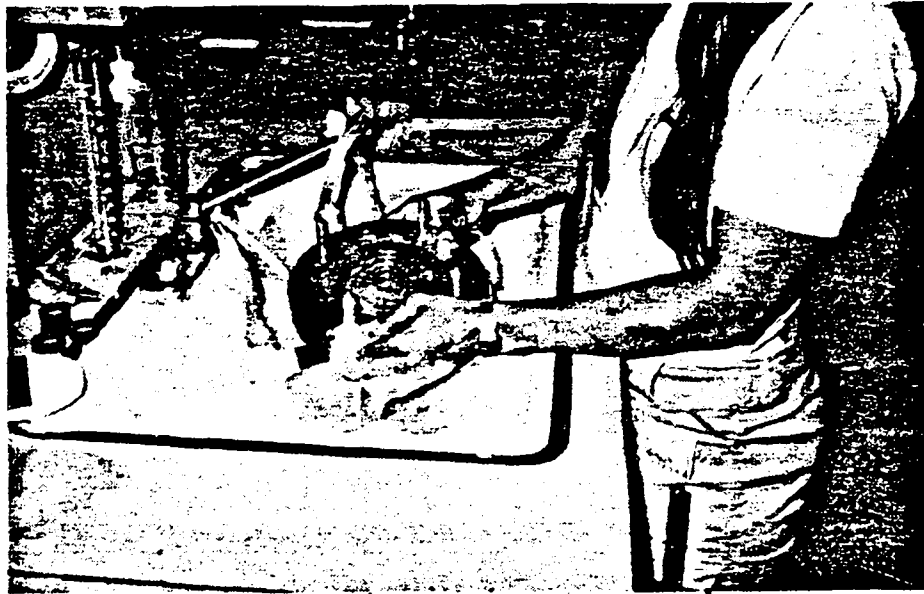

Figure 32. Washing membrane filter holder with hot, soapy water to make the filter Giardia "free".

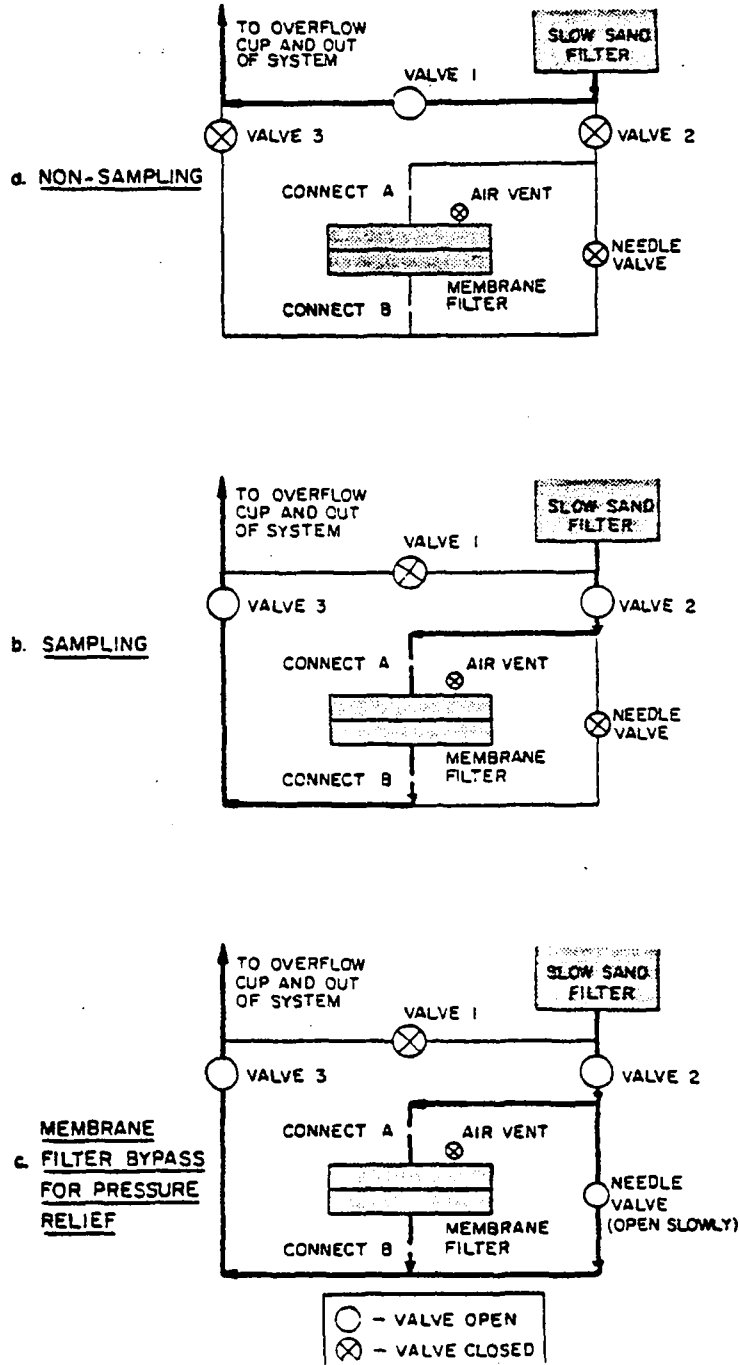

Figure 33. Schematic drawings of the three alternate flow paths during different steps of filter effluent sampling.

4. Slightly open valve No. 2, Figure 33(b), and allow flow to drip into the influent tube of the membrane filter at Point A until full.
5. Attach the influent tube to the tube connector at Point A and bleed remaining air through air vent valve.
6. When flow comes out of the membrane filter tube at Point B, attach this effluent tube to the tubing connector at Point B.
7. When pressures equilibrates within the filter holder, after about five minutes, open Valve No. 3 and close Valve No. 1, the main slow sand filter effluent line. This forces the entire effluent flow through the membrane filter. Figure 34 shows the holder.
8. Open Valve No. 2 completely. Figure 33(b) shows the valve positioning for effluent sampling.
9. Filter in this manner for a minimum of four hours, but no longer than permitted by pressure increase (i.e., 10 psi on filter feed pumps).
10. To remove the membrane filter, slowly open needle valve, allowing flow to bypass membrane filter. Simultaneously watch the piezometer or manometer monitoring differential pressure on the filter column to be sure there are no abrupt changes which will cause pressure shocks to occur.
11. When the pump pressure returns to its original reading, begin opening Valve No. 1, allowing flow to completely bypass the membrane filter. Especially watch pressure shocks at this step, as indicated by fluctuations in differential pressure.
12. Once Valve No. 1 is completely opened, Valves 2, 3, and the needle valve can be closed.
13. Remove membrane filter from sampling apparatus at Points A and B. The filter is now ready for washing as per Steps 10-16 of influent sampling procedure.
14. The entire effluent from the slow sand filter was passed through the slow sand filter. The volume of effluent flow passed through the membrane filter was measured volumetrically using a 190 L. tank.
15. The Giardia samples are taken to the laboratory of Dr. C.P. Hibler, Colorado State University Pathology Department, where the Giardia cyst counting and analysis is performed, described in Appendix K.

#### Bacteria Testing and Procurement—

Bacteria removal efficiency was used as an indicator of filter performance. Bacterial analyses included: fecal coliform bacteria, total coliform bacteria, and standard plate count bacteria. Testing was

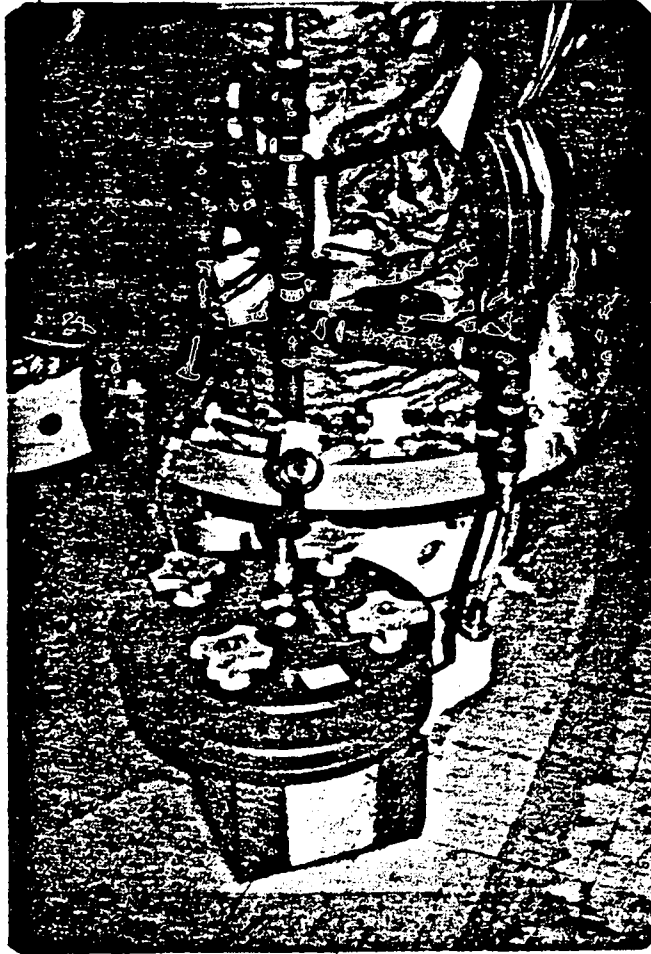

Figure 34. Membrane filter sampling for Giardia cysts on effluent of slow sand filter.

conducted using the following influent bacteria conditions: 1) naturally occurring bacteria concentrations which were presented in Horsetooth Reservoir water, 2) increased concentrations of coliform and standard plate count bacteria by the addition of primary settled sewage, 3) increased coliform and standard plate count bacteria concentrations by addition of cultured bacteria, and 4) decreased standard plate count bacteria by chlorination and dechlorination of the filter feed water. Wide variations in bacteria concentrations were used to assess the effect of such concentrations on removal.

Horsetooth Reservoir water contained approximately 0.6 total coliforms per 100 mL, < 0.5 fecal coliforms per 100 mL, and from 50 to 600 standard plate count bacteria per milliliter. These were the natural bacteria concentrations which occurred in the source water.

Fecal coliform and total coliform bacteria concentrations were increased by addition of primary settled sewage, or by addition of cultured *E. coli*. Sewage was used during the Phase I testing. During the Phase I tests it became apparent that for evaluation of the slow sand filtration process there was little difference between testing with sewage or with cultured coliforms. Both Phase II testing and Phase III testing were conducted with cultured coliforms. Concentrations could be controlled more easily than if sewage was used, and addition of nutrients and debris, which could affect experiments, was not a factor.

The *E. coli* were cultured in nutrient broth at 15°C. The culture was a stock culture used for confirmation testing by the EPA certified water quality laboratory in the Microbiology Department at Colorado State University. From 10<sup>6</sup> to 10<sup>8</sup> coliform were grown in 10 mL of nutrient broth and a portion of this culture was added to the filter feed tank. The culture was grown at 15°C to help prevent problems caused by temperature variations between growth conditions and testing conditions.

Standard plate count bacteria used in Phase III testing were obtained as described in the following. First, they were cultured in aerated nutrient broth for 24 hours at 30° to 35°C. The nutrient broth was seeded with raw water from Horsetooth Reservoir. After 24 hours of growth the mixture was centrifuged and the excess nutrient broth was removed. The concentrated bacteria were then rinsed by resuspending them in Horsetooth water, recentrifuging and removing the excess liquid. After rinsing, the bacteria were added to the batch filter feed tank. This substantially increased the influent standard plate count bacteria concentration without significantly increasing the nutrient or debris loading to the slow sand filters.

The influent standard plate count bacteria concentration was decreased by chlorinating and dechlorinating the water in the filter feed tank. This procedure was used only in Phase III testing. The filter feed tank held a 24 hour supply of water. The flow into the filters was discontinued for approximately 45 minutes each day while the tank was filled and the water



chlorinated; a chlorine residual of 5 mg/liter was maintained for this time period. Dechlorination was performed with approximately 700 mL of 10 percent sodium thiosulfate. This procedure reduced the standard plate count to below 10 colonies per milliliter.

The influent standard plate count bacteria concentration was increased to determine filter removal efficiencies as well as functional relationships between sand sizes and temperature. Because the filters grew and sloughed 100 to 200 standard plate count bacteria per milliliter and the raw water had 100 to 200 colonies per milliliter, these relationships could not be determined without influent spiking.

#### Bacteria Sampling—

Total coliform bacteria, fecal coliform bacteria, and standard plate count bacteria samples were obtained from the filter influent and effluent streams by grab samples collected in sterile 250 mL plastic bottles. The influent samples were collected from the filter feed tank and the effluent samples were collected out of a sample tap indicated in Figure 13 for Phase I testing and Figure 18 for Phase II and III testing. One sample was taken at each location and analyses were performed with aliquots from this sample. As discussed in Section 3.2.2. influent samples were compared to effluent samples obtained 24 hours later.

#### Turbidity and Particle Sampling—

Grab samples of influent and effluent turbidity were collected in the turbidimeter sample cells or in 300 mL glass bottles. The particle samples were collected in 500 mL glass bottles. The influent samples were collected from the filter feed tank and the effluent samples were collected from the same sample taps used for the bacteria sampling. Both the turbidity and particle bottles were washed thoroughly then rinsed with distilled water. The particle sample collection bottles were rinsed an additional time with particle free water, as described in Appendix N.

#### Analysis

##### Giardia Cyst Analysis—

Analysis for Giardia cysts involved microscopic examination of the samples. Two methods of processing for microscopic counting were used during these tests by Dr. C. P. Hibler, who directed this work. The first consisted of concentrating the sample by centrifuging and then floating the cysts in a 1.20 specific gravity zinc sulfate solution onto a cover slip and counting all of the cysts recovered. The second, called the micropipette technique, consisted of reducing the sample volume to 1 mL by centrifugation, taking a 0.05 mL aliquot, and then microscopically counting the cysts in the aliquot. Dr. C.P. Hibler of the Pathology Department of Colorado State University experimented with various analysis techniques and ultimately decided to use the micropipette technique. Appendix K contains a description of the analytical techniques used and an evaluation of each technique.

### Bacteriological Analyses—

The procedures of analyses used in this experimentation for measurement of total coliform, fecal coliform and standard plate count bacteria concentrations are described in Microbiological Methods for Monitoring the Environment. Tryptone glucose extract agar (Difco number DF0002-01-1) was used as the medium for standard plate count analyses instead of tryptone glucose yeast agar. This medium is specified by Standard Methods, 15th Ed. and was in stock.

Most of the analyses were conducted by graduate microbiologists from the Microbiology Department at Colorado State University. Those analyses performed by civil engineering graduate students attached to the project were supervised by the graduate microbiologists who were under the supervision of Dr. Sumner Morrison and Mr. Kirk Martin.

### Turbidity and Particle analyses—

Two turbidimeters were used for the Phase I testing, an H. F. Instruments, Model DRT200 R, flow-through turbidimeter, and a Hach Model 18900-10 ratio turbidimeter. Only the Hach Ratio Turbidimeter R was used for the Phase II and Phase III testing.

The H.F. instrument reads in nephelometric turbidity unit (NTU) and was calibrated with formazin standards. Through a system of valves, the flow from each of the Phase I filters was routed through the H.F. turbidimeter and monitored continuously. The influent turbidity was obtained as a grab sample and measured manually using a sample cell for the instrument.

Beginning in July 1982 a Hach Ratio Model 18900-10 R turbidimeter was used for turbidity analyses. The Hach meter was used because of its stability and use in the rapid sand research phase of the project. The rapid sand work required a turbidity sensitivity in the 1 NTU or less range, which was provided by the Hach instrument. The Hach nephelometer was standardized also against formazin standards.

A Coulter Counter, Model TA II R was used to analyze particle samples. Figures 35 and 36 show this apparatus. The Coulter Counter performs its analysis by measuring a change in resistance as particles pass through an orifice. A 1.5 percent by weight solution of NaCl was used as the conducting and particle carrying fluid for the analyses. This was determined to be the lowest concentration that would give an acceptable electrical conductivity through the 140  $\mu$ m orifice. Appendix N reviews the operating protocol for using the Coulter Counter.

### DATA HANDLING

All operating data and analysis results were recorded on computer coding forms for data processing. Appendix O contains a copy of each data sheet used, with samples of recorded data. These forms are constructed so that each line contains a set of data with the run number, date, time, and the corresponding measurements.

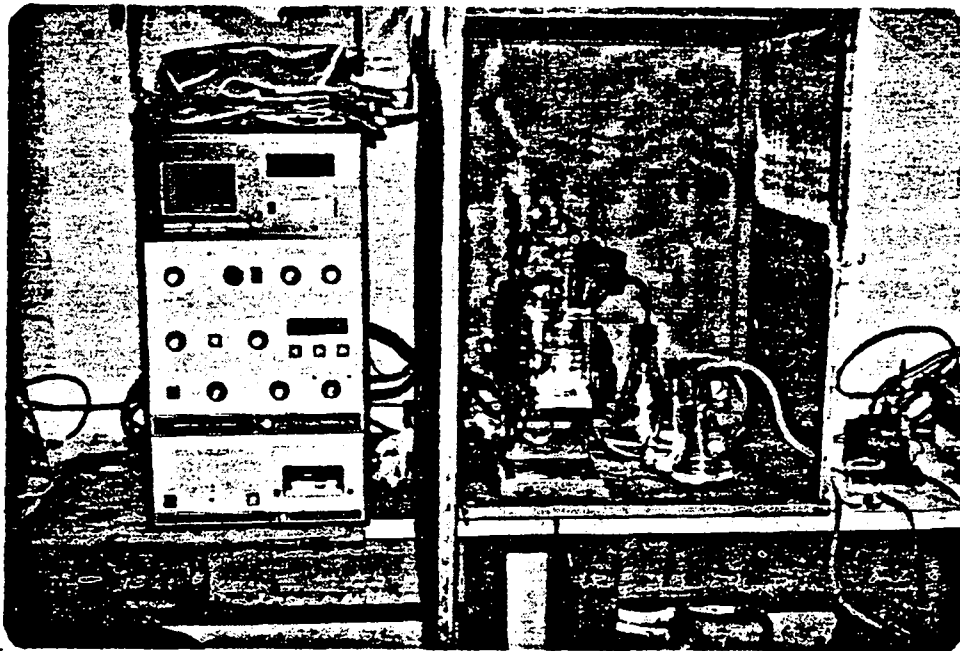

Figure 35. Coulter particle counter model TA II used in slow sand filtration testing.



Figure 36. Coulter Counter aperture stand.

The data on the computer-coded data sheets were entered into a master file in the CSU Cyber 720k computer. This master file was then transferred to the ERC HP 1000, the machine used for data processing. The master file was then split into categories according to test (i.e., coliform, Giardia, etc.) and filter number. A series of computer programs was written to extract the pertinent information from these subfiles. After the data were collated and pertinent calculations were made by the appropriate programs the output was transferred to the OAS word processing system. This transfer permits printing of a clear copy of results. The tables which appear in Appendices A-I are the products of these programs.

The data were also routed back to the Cyber 720 for plotting. A number of the graphs in this text were produced by the Cyber 720 and a Tech-Tronix R graphic terminal. Examples are: Figures 55-58 and the graphs in Appendix I.

#### QUALITY CONTROL

The quality control program for this research was designed to assure that valid measurements were obtained and that the equipment performed as intended. The following paragraphs describe the methods used to standardize, monitor, and provide quality assurance during the experimentation. Appendix J contains the forms used for the quality control program.

#### Flow-Measurement and Metering Pumps

Flow rates were monitored daily during test runs by time-volume measurements and were documented on the operational data sheet. These data were used to verify the conformity of the pumps to their respective standardization curves for the Phase I experiments. The time volume measurements were used to verify the flow from the orifices used in the Phase II and III experiments.

Pumps were standardized by time-volume measurements made at different flow rates and at different pressures. Appendix J contains the pump-standardization curves in terms of flow versus pump setting at various pressures.

#### Turbidity Meters

The H. F. Instruments R and the Hach Ratio Turbidimeters R were both calibrated with formazin standards as required by the manufacturer. The H. F. Instruments model was checked daily with a 0.14 NTU manufacturer-supplied reference standard and adjusted as needed with a reference adjustment knob. The Hach Ratio instrument was also checked daily with 18.0 NTU latex factory standard (a secondary standard). The instrument was restandardized as recommended by the manufacturer when it drifted from 18.0

NIU. Appendix J contains a standardization form used with the Hach and HF turbidimeter.

### Temperature

All thermometers were standardized against a National Bureau of Standards thermometer. Discrepancies between the two were marked on each thermometer and the correction as applied when used. Temperature gauges in the filter heads were similarly standardized and these discrepancies were corrected for by adjustment screws on the gauges. Appendix J contains the NBS calibration certificate and a thermometer standardization quality control form.

### Pressure

Piezometers were not standardized, but were used as the standard for other pressure-measuring devices. Visual checks for air bubbles in the piezometers were made periodically. Pressure gages were standardized against piezometers and variations were recorded as a correction factor for each pressure gauge. Appendix J contains pressure gage standardization forms.

### Microbiological Controls

#### Automatic Autoclave—

The autoclave operation was checked by the manufacturer and all instruments and gauges were certified as operating correctly. In addition, the autoclave was checked each time it was used by heat-sensitive tape and a recording thermometer.

#### Manual Autoclave—

The autoclave was checked each time with heat sensitive tape and periodically by manually checking the pressure and temperature gauges. Appendix J contains an autoclave quality control form.

#### Incubator and Water Bath—

The temperatures of the incubator and water bath were checked and recorded every other day when in use. The incubator was allowed to stabilize for two hours when temperature adjustments were made. Appendix J contains quality control forms for these pieces of equipment.

#### Bacterial Analysis—

The agars and analyses used in microbiological testing were checked according to the following procedures:

##### 1. Total Coliform Analyses

- a. Filter sterility was monitored by randomly choosing one of the 0.45  $\mu\text{m}$  filters and placing it on a petri dish of the standard coliform media. (The procedure followed is the same as that for routine analysis except no water is

filtered.) The plate was checked for growth after 24-hour incubation. This was done daily during sampling process. Periodic checks of the dilution water were also conducted. Appendix K contains a quality control form.

- b. Whenever possible, duplicate plates of each sample dilution were simultaneously prepared and counted. The average number between corresponding plates was the number reported.
- c. Total coliform plates were refrigerated and kept for no longer than ten days.

## 2. Standard Plate Count Bacteria

- a. Standard petri dishes were poured with the plate count agar alone (no water sample) to check sterility of the media. This was done a minimum of once every two days when testing. Appendix J contains a quality control form.
- b. Duplicate plates of each sample dilution were prepared, counted, and the average number recorded as results.
- c. Plate count agar was refrigerated and was kept no longer than two weeks.

### Membrane Filters

To prevent Giardia contamination from one sample to another, the membrane filter holders were washed with hot soapy water and rinsed with cold tap water between samples. Also, the membrane filters were used for only one sample and then discarded.

### Data Entry

The data were entered into the computer manually by key punch personnel. After the data were entered they were verified by the same key punch personnel. A copy of the data was then printed out and two people would check the computer hard copy of the data against the original data form.

## SECTION 4

### RESULTS AND DISCUSSION

This chapter presents, in tables and graphs, the experimental results with a corresponding discussion and interpretation of the results. The discussion explains observed relationships, interprets their significance, and adds qualifications. The results are organized into four areas: 1) effects of process variables; 2) removal of dependent variables, e.g., Giardia cysts, bacteria and turbidity; 3) routine monitoring of filter operations, i.e., headloss, hydraulic loading rate and temperature; and 4) removal mechanisms.

The tables and graphs were constructed from data in Appendices A through H. All of the data are in these appendices and include the following number of analyses: 309 Giardia, 1087 total coliform bacteria, 108 fecal coliform bacteria, 1309 standard plate count bacteria, 2108 turbidity and 52 particle.

#### ROLE OF PROCESS VARIABLES

This section discusses the influence of the process variables on filter performance. The process variables considered were: 1) hydraulic loading rate, 2) sand size, 3) sand bed depth, 4) temperature 5) influent bacteria concentration, and 6) conditions of operation.

#### Hydraulic Loading Rate

Table 13 shows the influence of hydraulic loading rate on percent removals for all dependent variables tested, e.g. total coliform bacteria, fecal coliform bacteria, standard plate count bacteria, turbidity, particles and Giardia cysts. The data shown are average removals calculated using data abstracted from Appendix A. The numbers of data points used for each result are shown in Table 13 also.

Each row in Table 13 is termed a "vector". Figures 37 through 40 are plots of vectors in Table 13 for total coliform bacteria, turbidity, standard plate count bacteria and Giardia cyst removals, respectively, plotted against hydraulic loading rate. The fecal coliform vector was not plotted but its trend is similar to the total coliform vector. The particle removal vector was not plotted either. The filter was shedding cyst-size biological particles, as observed by Dr. Hibler during microscopic examinations, and thus the particle count parameter using the 6.35 to 12.7  $\mu\text{m}$  size range was considered as an unsuitable measure of filter performance.

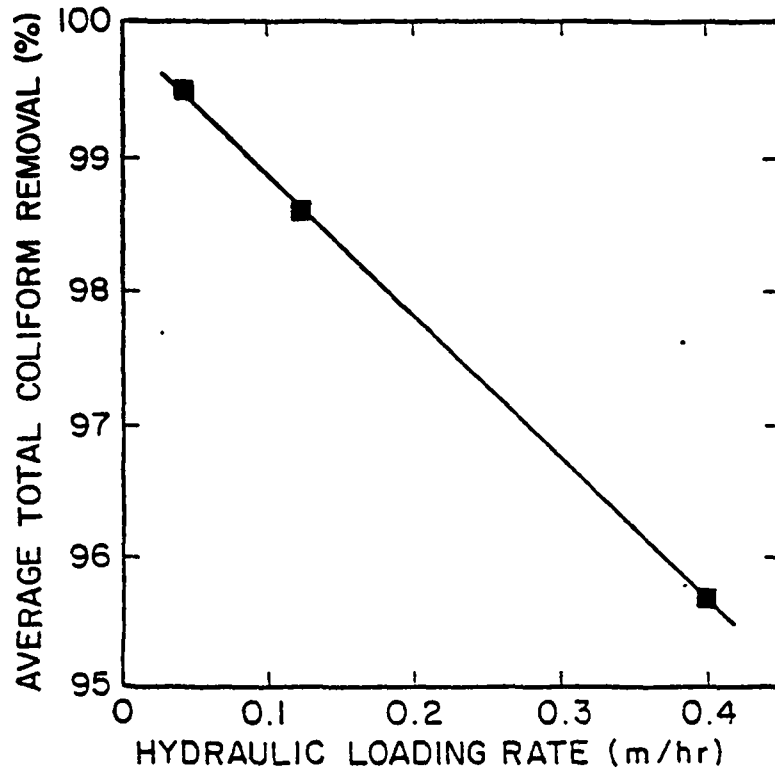

Figure 37. Effect of hydraulic loading rate on total coliform bacteria percent removal. The plotted points are geometric mean removals for all operating conditions. The data were abstracted from Table 13.



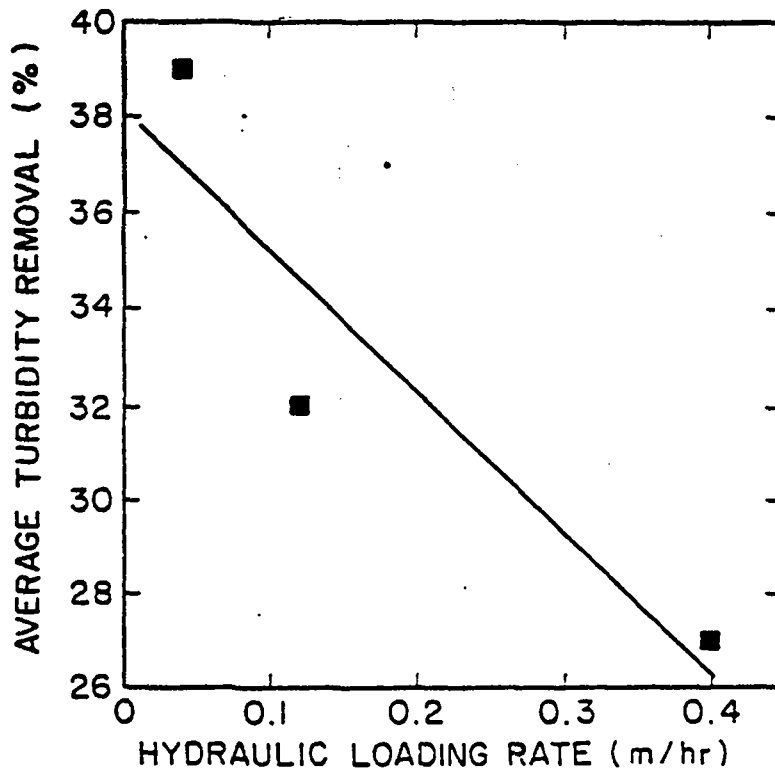

Figure 38. Effect of hydraulic loading rate on turbidity percent removal. The plotted points are average removals for all operating conditions. The data were abstracted from Table 13.

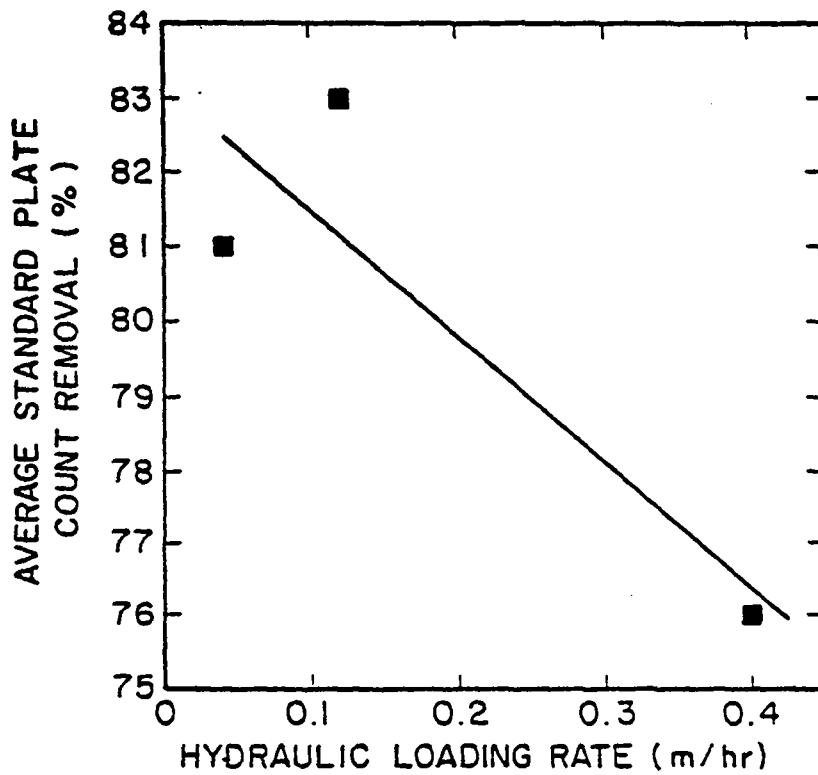

Figure 39. Effect of hydraulic loading rate on standard plate count bacteria percent removal. The plotted points are geometric mean removals for all operating conditions. The data were abstracted from Table 13.

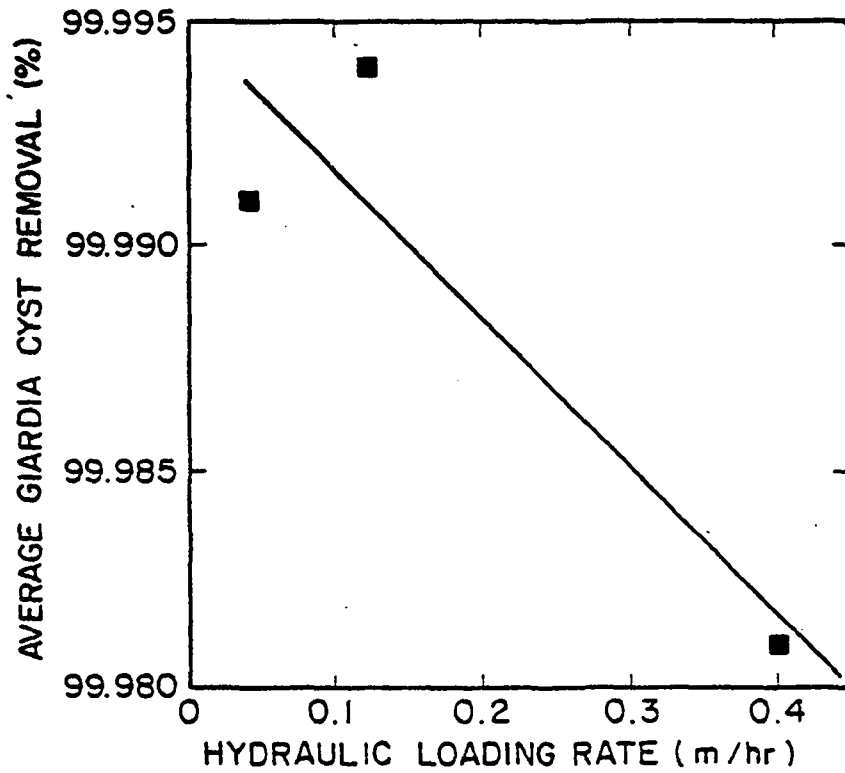

Figure 40. Effect of hydraulic loading rate on Giardia percent removal. The plotted points are average removals for all operating conditions. The data were abstracted from Table 13.

Table 13. Slow sand filter treatment efficiency as effected by hydraulic loading rate, Phase I testing.

	Low Rate Filter 1 0.04m/hr	Control Filter 2 0.12m/hr	High Rate Filter 3 0.40m/hr	Number of Samples
Total Coliform Removal (%)✓	99.5	98.6	95.7	81
Fecal Coliform Removal (%)✓	99.7	99.5	99.1	27
Standard Plate Count Removal (%)✓	81	83	76	117
Turbidity Removal (%)	39	32	27	297
Particle Removal (%) (6.35-12.7 μm)	97	99	98	13
Giardia Cyst Removal (%)	99.991	99.994	99.981	74

✓ These removal values were calculated with the geometric mean influent and effluent concentrations.

Each of the four plots show that removal decreased with increasing hydraulic loading rate. The decrease in percent removal caused by increasing hydraulic loading rate from 0.04 m/hr to 0.40 m/hr was from 99.5 to 95.7 percent for total coliforms; 82 to 76 percent for standard plate count bacteria; 39 to 27 percent for turbidity; and 99.995 to 99.981 percent for Giardia cysts. The low and high rate results for coliforms and turbidity were found to be statistically different at the 0.1 percent significance level ( $p=0.001$ ) for a two way test of the variance. The Giardia values were not statistically different. Nevertheless, the trend shown is "expected," and it is consistent with the others.

Table 14 is another analysis of the data, showing the "breakthroughs" of total coliform bacteria at the three hydraulic loading rates, and the average concentrations for each breakthrough group. It shows that Filter 1 had only 35 breakthroughs during the entire testing period, while Filter 2 had 59, and Filter 3 had 70. The average coliform concentrations during the breakthroughs were 13.4 coliforms/100 mL, 59.6 coliforms/100 ml, and 152.5 coliforms/100 mL for Filters 1, 2 and 3, respectively. These breakthrough data also show that removals decrease with increasing hydraulic loading rate.

The trends in Figures 37 through 40 show clearly that filter removal efficiency is functionally dependent upon hydraulic loading rate. These results document the accepted premise regarding the influence of this parameter. The trends shown are not, however, critical to design. Removal of total coliform bacteria is reduced from 99.5 percent at 0.04 m/hr to 95.7 percent at 0.40 m/hr, which is a change of only 3.8 percent. The change in removal of Giardia cysts is hardly perceptible; removal approaches 100 percent regardless of hydraulic loading rate, albeit a trend is shown.

Table 14. Correlation of total coliform breakthroughs to hydraulic loading.

Filter	Hydraulic Loading Rate (m/h)	Number of Breakthroughs in the Filter Effluent (No.)	No. of Tests	Average Concentration of Coliforms during Breakthroughs <sup>1/</sup> (coliforms/100 mL)
1	0.04	35	81	13.4
2	0.12	59	81	59.6
3	0.40	70	81	152.5

<sup>1/</sup> These values are averages of coliform concentrations when breakthroughs occurred. They do not include samples where the effluent concentration was determined to be zero. Complete data are given in Appendix D.

The cost savings in using a design at 0.40 m/hr opposed to 0.04 m/hr could be substantial, while the difference in percent removals is slight. Thus the use of the higher hydraulic loading rate should not be declined because of reduction in effectiveness. Other design considerations may influence more strongly the case for a lower hydraulic loading rate. The frequency of schmutzdecke removal, for example, will increase if a higher hydraulic loading rate is used. This will cause an increase in operating costs, which must be weighed against the lower capital costs.

The improved filter performance at a reduced hydraulic loading rate is due most probably to the biological nature of the slow sand filter. The detention time within the filter increases with lower hydraulic loading rate and thus the opportunity increases for the contaminants to contact and be retained by the adsorption sites on the filter sand. These adsorption sites are provided by the biopopulation within the filter.

Sand Size

Table 15 shows the average removals of total coliform bacteria, standard plate count bacteria and turbidity as affected by sand size. These data were obtained as a part of the Phase III testing and consisted of nine analyses for each of three effective sand sizes.

Figure 41 is a plot of the coliform removal vector in Table 15. The plot shows an increase in treatment efficiency with a decrease in sand size. The coliform removal improved from 96 percent to 98.6 percent to 99.4 percent for effective sand sizes of 0.615, 0.278 and 0.128 mm, respectively. These removal values are significantly different at a significance level greater than 0.1 percent ( $p=0.001$ ) for a two way test of variance.

The turbidity data vector in Table 15 did not show a trend and neither did the standard plate count data. The turbidity in the Horsetooth Reservoir water, used in all testing, is comprised of small clay particles and there is question as to whether it is a suitable indicator of filter performance. The particles causing turbidity in other raw waters, however, may be more susceptible to removal by slow sand filtration. Neither is the standard plate count data a suitable indicator for comparison of performance. The

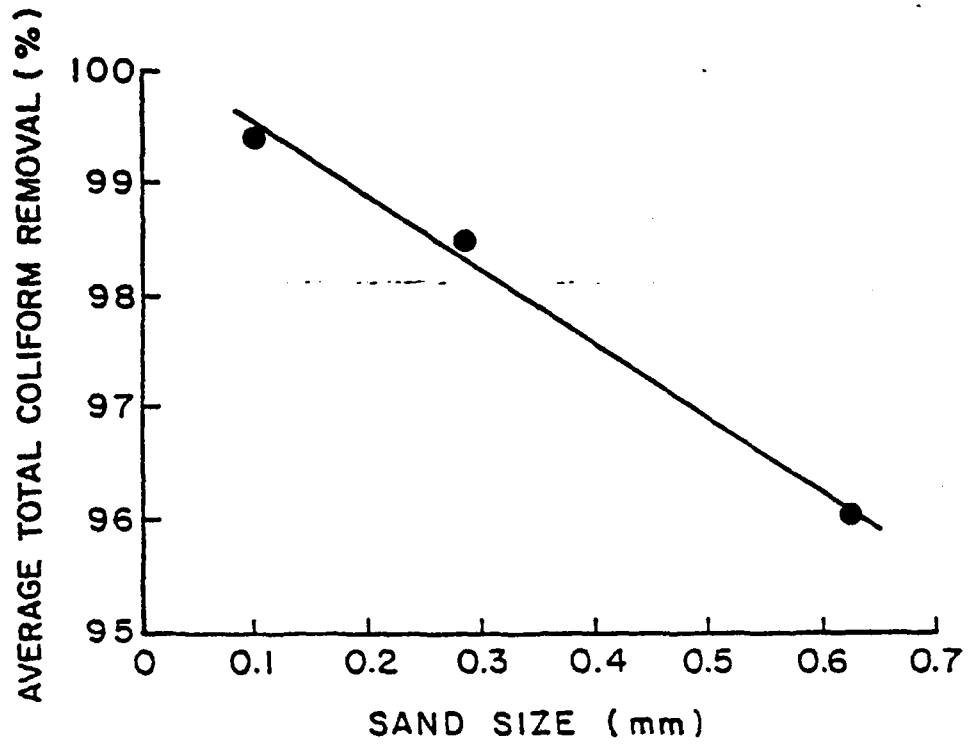

Figure 41. Effect of sand size on removal of total coliform bacteria for slow sand filtration, Phase II and Phase III experiments.

Table 15. Effect of sand size on slow sand filter treatment efficiency Phase III testing.

	Small Sand Filter 3 0.13 mm	Control Filter 1 0.29 mm	Large Sand Filter 5 0.62 mm
Number of Samples	9	9	9
Total Coliform Removal (%)	99.4	98.6	96.0
Standard Plate Count Removal (%)	0	16	12
Turbidity Removal (%)	15	16	-26

filter continually grows and sloughs 100 to 200 standard plate count bacteria per milliliter of effluent. The influent concentrations averaged about 150 colonies/mL. Thus standard plate count bacteria removal is very low or negative and is not a suitable indicator for comparison of filter performance unless the influent concentration is sufficiently large to overwhelm the base level effluent concentration. Table 15 shows percent removal of 0, 16, and 12, for the three sand sizes, which do not show a trend, but do show that percent removals were low.

The above idea was tested in a special experiment designed to overwhelm the filter influent flows with high concentrations of standard plate count bacteria for each of the three filters having different effective sand sizes. The filter influents were spiked with bacteria as described in Section 3.3. Table 16 presents the data obtained, showing that there was indeed an increase in standard plate count bacteria removal for the smaller sand size. The effluent of the filter with large sand emitted 1054 colonies/mL while the filter with small sand emitted only 470 colonies/mL. Both of these filters had been in operation for 280 days and had mature schmutzdeckes.

Table 16. Standard plate count bacteria removal as affected by sand size, Phase III testing. Filter 1 was the control. Bacteria concentrations are geometric means calculated from data abstracted from Table F-6, Appendix F.

	Filter 1	Filter 2
Sand Size (mm)	0.278	0.615
Number of Samples	10	10
Average Standard Plate Count Influent Concentration (No./mL)	469,000	469,000
Average Standard Plate Count Effluent Concentration (No./mL)	470	1,054

The smallest sand size ( $d_{10} = 0.128$  mm) was not included in this table since the effluent for Filter 3 had not stabilized for standard plate count values prior to the test. This was determined by analyzing the data in Appendix F and observing that the removals were still decreasing with time.

The influence of sand size on treatment efficiency was also evaluated for filters operated at 5°C. Table 17 shows removal data for filters operated at 5°C with 0.287 mm sand and 0.615 mm sand. Coliform removal decreased from 87 percent to 83 percent when the filter sand was increased from 0.287 mm to 0.615 mm, confirming the trend shown in Figure 41. Standard plate count bacteria showed the same trend, but the results are not considered significant since the influents were not spiked.

Table 17. Effect of sand size on slow sand filter treatment efficiency while being operated at 5°C, Phase II testing.

	Control Filter 6 0.278mm	Large Sand Filter 5 0.615mm	Number of Samples
Total Coliform Removal (%)	87	83	82
Standard Plate Count Removal (%)	64	60	80
Turbidity Removal (%)	8	8	87

The trend shown, i.e., that the filter effectiveness is increased with smaller sand, is not due simply to increased surface straining by the smaller sands. The role of straining was ascertained by an experiment in which the sand surface of Filter 2 was coated with a deposit of Marville C-545 R diatomaceous earth ( $d_{10} = 0.013$  mm) at 3 kg/m<sup>2</sup> (which was about 15 mm in thickness). Further, the schmutzdecke was allowed to develop for 40 days on the diatomaceous earth. The results of this test, given in Table 18, show that the total coliform bacteria, standard plate count bacteria, and turbidity removals were improved only slightly by the diatomaceous earth coating. The increase in coliform removal, from 97.7 percent to 98.5 percent is no better than that which occurred with the small sand, which had a  $d_{10}$  of 0.13 mm. These results then point toward a removal mechanism of adsorption on the biological material attached to the sand grain, with possible metabolism of those materials adsorbed which are metabolizable.

Table 19 summarizes results of six *Giardia* test runs conducted with an effective size of 0.615 mm. The data show that removal is > 99.9 percent when the filter is biologically mature. Even with new sand and gravel support, cyst breakthrough did not occur at 0.12 m/hr. Breakthrough occurred only at a hydraulic loading rate of 0.47 m/hr with new sand and new gravel support. Control filters operated at the same time as each of these tests with 0.278 mm sand also had no cyst breakthrough. These results show that



Table 18. Slow sand filter treatment efficiency as affected by a diatomaceous earth coating of the sand surface, Phase III testing.

	Control Filter 1	Diatomaceous Earth Coated Filter 2
Number of Samples	6	6
Total Coliform Removal (%)	97.7	98.5
Standard Plate Count Removal (%)	78	84
Turbidity Removal (%)	8	9

Table 19. *Giardia* cyst removal as affected by an effective sand size of 0.615 mm.

Filter No.	Test No	Biological Condition of Filter	Hydraulic Loading Rate (m/hr)	Influent Cyst Conc. (c/L)	Effluent Cyst Conc. (c/L)	Percent Removal <sup>2/</sup> (%)
5	1	Mature	0.12	3000	0	> 99.98
	2	Mature <sup>1</sup>	0.12	1456	0	> 99.92
	3	Mature	0.12	1845	0	> 99.94
7	1	New	0.12	3227	0	> 99.99
	2	New <sup>2</sup>	0.12	2768	0	> 99.99
	3	New	0.47	2768	26	99.06

- <sup>1/</sup> Mature refers to a biologically mature schmutzdecke, sand bed and support layer, i.e., the biological population is at steady state,
- <sup>2/</sup> New refers to new sand and gravel support with no prior filtration, i.e., no biological development in the filter.
- <sup>3/</sup> The "greater than" sign was used when cysts were not recovered; the percent removal shown is the detection limit, calculated as shown in Appendix K.

for a hydraulic loading rate of 0.12 m/hr *Giardia* removal approaches 100 percent, even for sand having  $d_{10} = 0.615$  mm.

The results in Tables 15, 16, and 17 demonstrate that decreasing the sand size will improve filter performance. But data from the diatomaceous earth coating experiment shown in Table 18 indicates that the removal mechanism is not simply straining. Increased removals can then be attributed to increased surface area resulting in increased adsorption sites within the filter, i.e., decreased sand size increases surface area for biological growth.

## Sand Bed Depth

Table 20 shows the influence of sand bed depth on removals of total coliform bacteria, standard plate count bacteria and turbidity. These removals are calculated using all data, i.e., during start-up and after schmutzdecke removal. The data show a small decrease in coliform removal, e.g., 97 percent versus 95 percent, for a decrease in sand bed depth from 0.97m to 0.48m. A two way test of the variance shows these results to be significantly different at 0.2 percent significance level ( $p=0.002$ ).

Table 20. Slow sand filter treatment efficiency as affected by sand bed depth, Phase II testing.

	Full Sand Bed Filter No. 1	1/2 Sand Bed Filter No. 2	Number of <sup>1/</sup> Samples
Sand Bed Depth (m)	0.97	0.48	
Total Coliform Removal (%) <sup>1/</sup>	97	95	82
Standard Plate Count Removal (%) <sup>1/</sup>	-32	3	80
Turbidity Removal (%)	13	13	87

<sup>1/</sup>The coliform and standard plate count removals are calculated using geometric means of influent and effluent data.

The standard plate count data and the turbidity data in Table 20 show no trends. This is due to the same conditions, described in the preceding chapter, which preclude their use for comparison of filter performance. The standard plate count tests were conducted with the low, naturally occurring, influent concentrations, i.e., without spiking. Turbidity data was not an appropriate indicator because of the small size clay particles which comprise the turbidity and the inability of the filter to remove them.

Figure 42 shows the two data points from Table 20 plotted as coliform percent remaining versus sand bed depth. The trend line shown represents the expected functional relationship of decreasing coliform removal with decreasing sand bed depth. The line is anchored at 100 percent remaining at a 0.0m bed depth.

Giardia removal was not affected by the decreased sand bed depth. Results given later (in Table 31) show that Giardia removal was 100 percent (qualified by detection limits) at the bed depth of 0.48 m as well as at the full bed depth of 0.97 m.

The relationship shown in Figure 42 indicates that percent bacteria remaining is not highly sensitive to sand bed depths above 0.48 m. In practice this means that a series of schmutzdecke removals, scraping off the top two centimeters of the sand bed, will not seriously impair the efficiency of the filtration process, and that the attrition of the sand bed to a depth of 0.48 m is acceptable, which is consistent with the literature.

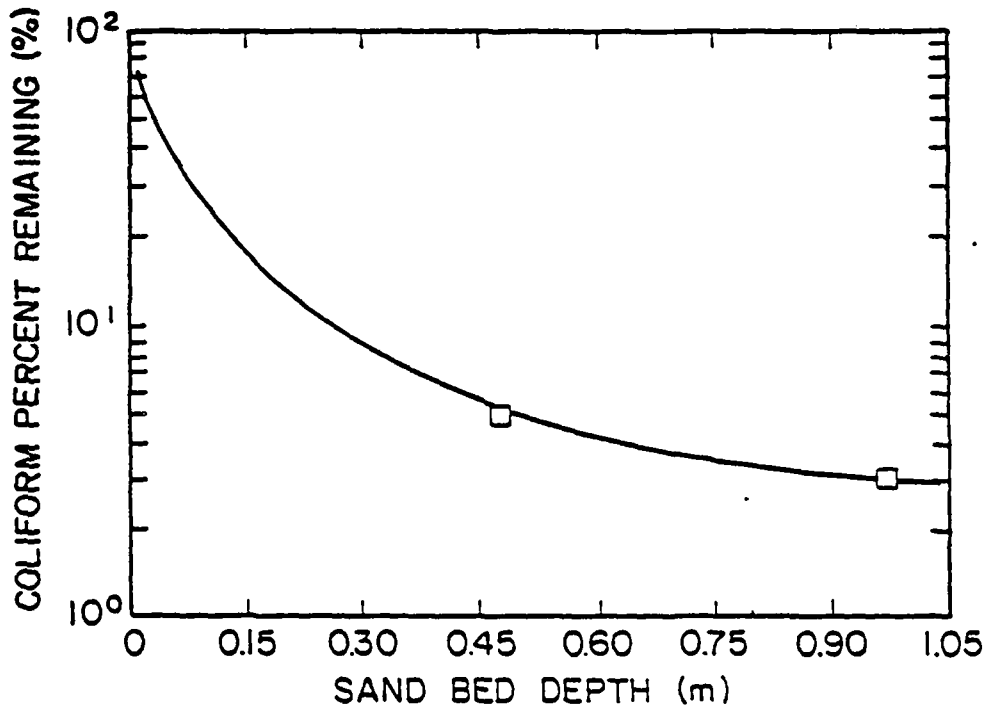

Figure 42. Effect of sand bed depth on slow sand filter performance.

LIBRARY  
 INTERNATIONAL REFERENCE CENTRE  
 FOR DOCUMENTATION AND  
 INFORMATION SERVICES

## Temperature

Table 21 shows the effect of temperature testing at 17°C, and 5°C, and at 17°C and 2°C on removals of total coliform bacteria, standard plate count bacteria, and turbidity. These pairs of data for Phases II and III, respectively, show that percent removals of coliform bacteria are affected significantly by temperature. The removals of total coliform bacteria were 97 percent and 87 percent at 17°C and 5°C respectively for Phase II, and 99 percent and 92 percent at 17°C and 2°C respectively for Phase III.

Table 21. Bacterial and turbidity removal by slow sand filtration as effected by temperature. Both filters had hydraulic loading rates of 0.12 m/hr and effective sand size of 0.278 mm.

	Phase II			Phase III		
	Control Filter 1 17°C	Cold Filter 6 5°C	Number of Samples	Control Filter 1 17°C	Cold Filter 6 2°C	Number of Samples
Total Coliform Removal (%)	97	87	82	99	92	9
Standard Plate Count Removal (%)	-32	64	80	17	72	9
Turbidity Removal (%)	12	7	87	16	21	9

The effect of temperature is borne out further by the results shown in Table 22 which shows that reduced temperature decreases the removal of standard plate count bacteria by slow sand filtration. The effluent concentration at 17°C was 100 times lower than at 2°C. The influents to the control (Filter 1) and to the low temperature filter (Filter 6) were spiked with approximately  $5 \times 10^5$  bacteria/milliliter and so these tests are considered valid. As discussed, this was done to offset the effects of bacteria propagation and release from the filters. No specialized testing was performed at 5°C.

Table 22. Effects of temperature on standard plate count bacteria removal by slow sand filtration, Phase III testing.

Temperature	Filter 1 17°C	Filter 6 2°C
Number of Tests	10	10
Influent Standard Plate Count Concentration (No./mL)	469,000	469,000
Effluent Standard Plate Count Bacteria (No./mL)	470	46,300

Note: These geometric means are calculated from data presented in Table F-6, Appendix F.

Table 23. Giardia removal by slow sand filtration as effected by temperature, Phase I testing.

Filter Number	Hydraulic Loading Rate (m/h)	Run Number	Temp. (°C)	Age of Schutzdecke (weeks)	Influent Giardia Cyst Concentration (c/L)	Number of Effluent Samples (No.)	Effluent Volume Sampled (L)	Number of Cysts Detected in Effluent (No.)	Effluent Cyst Concentration (c/L)	Removal %
1	0.04	54	15	3	500	5	84	13	0.253	99.949
		60	5	5	500	5	81	0	0.000	100.000
		66	15	11	50	7	175	5	0.050	99.900
		69	5	12	50	5	140	8	0.116	99.772
2	0.12	53	15	3	500	5	225	16	0.140	99.977
		59	5	5	500	5	220	5	0.035	99.993
		65	15	11	50	7	429	4	0.016	99.968
		68	5	12	50	5	345	7	0.041	99.918
3	0.40	55	15	3	500	5	346	68	0.321	99.936
		61	5	5	500	5	366	26	0.111	99.978
		67	15	2	50	7	1098	7	0.011	99.978
		70	5	3	50	5	962	8	0.017	99.966

✓ Qualified by the detection limits shown in Table 30.

Note: Data in this table were extracted from Table 14.

Table 23 shows the Phase I Giardia removal results for operating temperatures of 5°C and 15°C. The data are organized by hydraulic loading rate and by comparable schmutzdecke ages. No apparent change in filter effectiveness is shown when the 5°C test runs are compared with 15°C test runs for the same conditions. The 5°C temperatures during the Phase I testing were maintained only during the 5°C test runs; so it is unlikely that the biological populations within the filters had sufficient time to be affected by the change. Because of this deficiency, temperature testing was included in the Phase II program. Two filters were operated continuously at 5°C.

Table 24 shows the Phase II Giardia removal results for operating temperatures of 5°C and 17°C. Filters 5 and 6 were operated for the entire testing period at 5°C. As shown there were no cyst breakthroughs for these low temperature filters or for the control, Filter 1. These results corroborate the Phase I findings and demonstrate that temperature has no observed effect on Giardia cyst removal.

Table 24. Giardia removal as effected by temperature, all filters were biologically mature and operated at 0.12 m/hr, Phase II testing.

Filter No.	Test No.	Temperature (°C)	Influent Cyst Concentration (cysts/liter)	Effluent Cyst Concentration (cysts/liter)	Cyst Removal (%)
1	1	17	3000	0	> 99.99
	2	17	1956	0	> 99.93
	3	17	1845	0	> 99.94
5	1	5	3000	0	> 99.98
	2	5	1956	0	> 99.92
	3	5	1845	0	> 99.94
6	1	5	3000	0	> 99.99
	2	5	1956	0	> 99.92
	3	5	1845	0	> 99.93

#### Influent Contaminant Concentration

Figures 43 and 44 are plots of influent concentrations versus effluent concentrations for total coliform bacteria and standard plate count bacteria respectively. These data were abstracted from Appendices D and F, and are from Phase I testing. Each figure shows two log cycles of scatter for all the plotted data but the plots of the averages within each indicated range show that an increase in influent concentration will cause an increase in the effluent concentration. The scatter is due partially to the fact that all data were plotted without attempting to achieve any resolution for varying test conditions, e.g., microbiological maturity of the sand bed. Similar results were obtained for data generated for the filters operated at 0.04 m/h and 0.40 m/h.

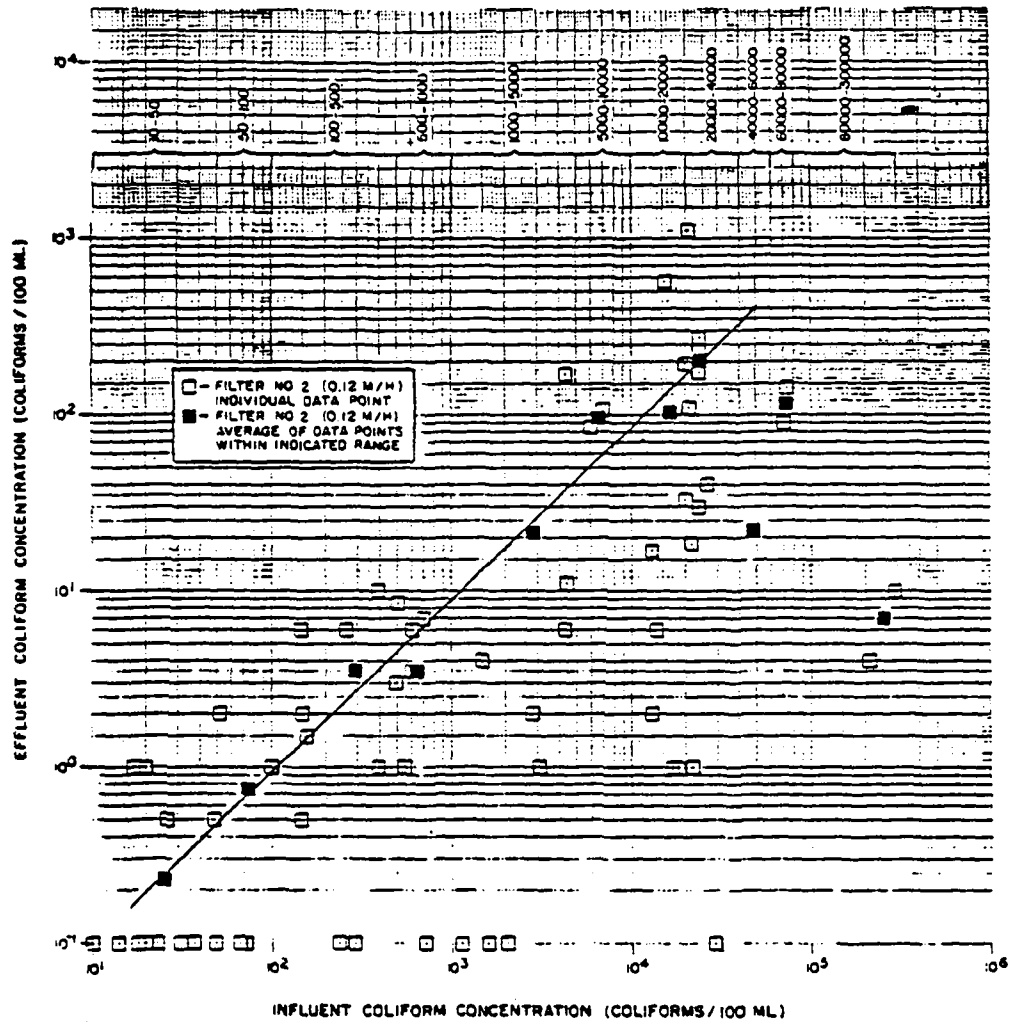

Figure 43. Effluent coliform concentration as affected by influent coliform concentration at hydraulic loading = 0.12 m/h. When no coliforms were found in an effluent sample the value was plotted at  $10^{-1}$  but 0 was used in the calculation of the mean.

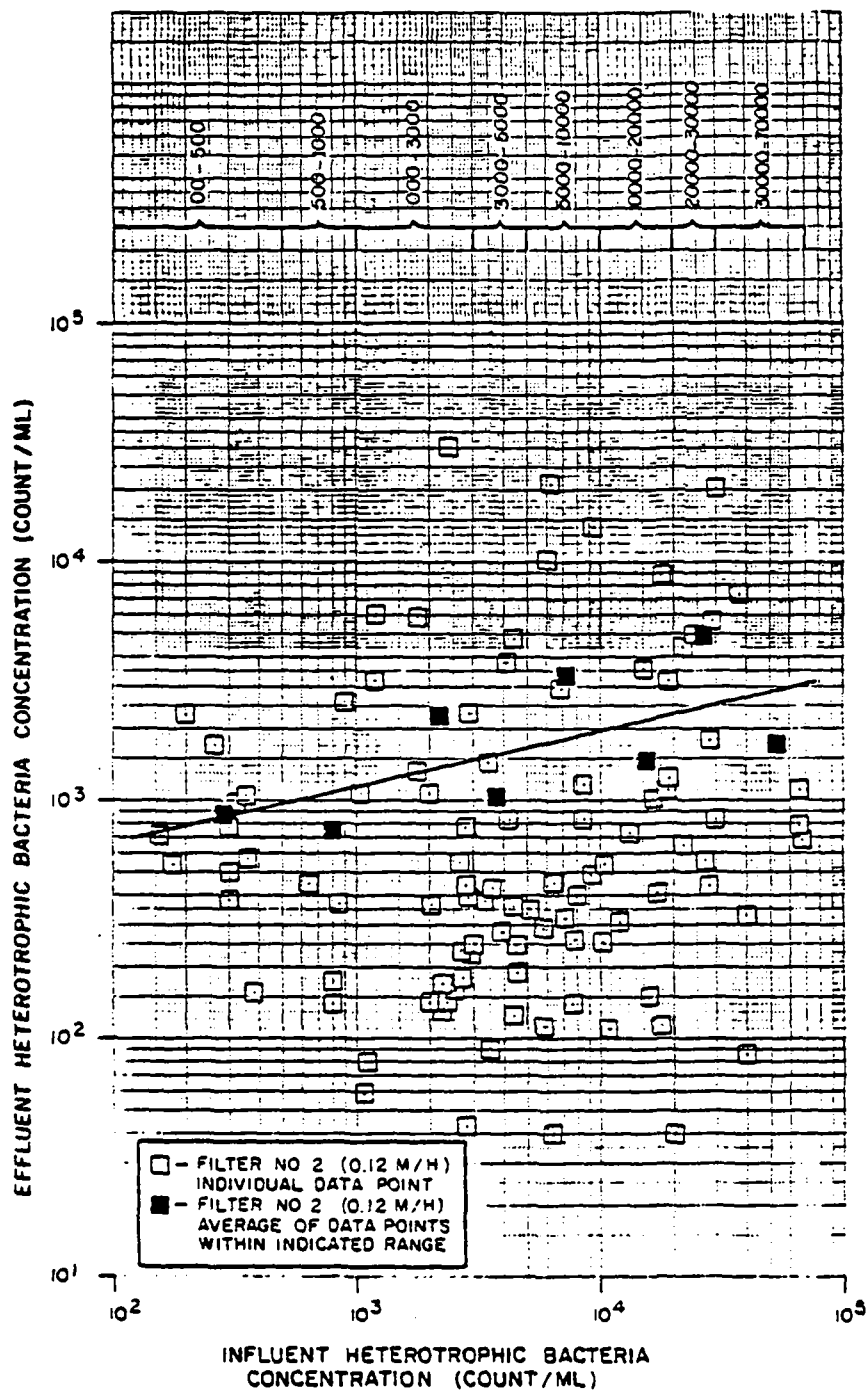

Figure 44. Effluent standard plate count bacteria concentration as affected by influent standard plate count bacteria concentration at hydraulic loading rate = 0.12 m/h.



Replotting the data in Figures 43 and 44 in term of percent remaining on the ordinate, it is seen in Figures 45 and 46 that percent remaining declined as the influent bacteria concentration increased. While the three points for the higher influent concentrations in Figure 45 decline sharply, the trend line is shown with only a slight slope, which gives more weight to the other points. These data were abstracted from Appendices D and F, Phase I testing. Similar results were obtained for data generated at hydraulic loading rates of 0.04 m/hr and 0.40 m/hr.

Figure 47 is a time series plot of influent and effluent total coliform results for the first 115 days of Phase II testing for Filter 1, the control, and Filter 5, operated at 5°C with 0.615 mm sand. These data were abstracted from Appendix D, Phase II testing. The influence of influent bacteria concentration on filter effluent concentrations is clearly indicated by the corresponding responses of the effluent concentrations for the two filters. The influence is evident during filter start-up, defined here as day 0 to approximately day 50, as well as for established operation, day 50 to day 115. The same relationships can be seen in plots of total coliform concentration data for Filters 2, 3, 4 and 6 as well. These plots using Phase II data, corroborate the interpreted trends for the Phase I data in Figures 43 and 44.

Although a similar removal relationship could exist for influent *Giardia* cyst concentrations, none was found, for an influent range of 50 to 5000 cysts/liter. Tests were not conducted with an influent concentration greater than 5000 cysts/liter because it was deemed more important to investigate other relationships. Also, effects caused by changes in influent concentrations of cysts would be extremely hard to define, or they could be masked by the effects of other variables.

#### Modes of Operation

Four modes of operation are defined here as: 1) filter start-up, 2) replaced sand, 3) removed schmutzdecke, and 4) steady state operation. How these different modes of slow sand filtration affect percent removals is the subject of this section.

#### Effect of Modes of Operation on the Biological Community—

Based upon observations from this work it can be asserted that the condition of the biological community within a slow sand filter is dependent on the mode of filter operation. Figure 48 is a matrix we have constructed which relates the state of the biological community at different filtration zones in the filter to the four modes of operation. The biological community is defined to be in one of two states, "growth" or "mature". Growth refers to a nonsteady state condition where the amount of biological mass is less than the level that can be supported by the mass nutrient loading. Consequently, the biological community is growing and increasing in mass. A new sand bed having no biological community is included in this definition; the biological community is defined to be in a "growth" condition. The "mature" community is at steady state and the biological mass is in balance

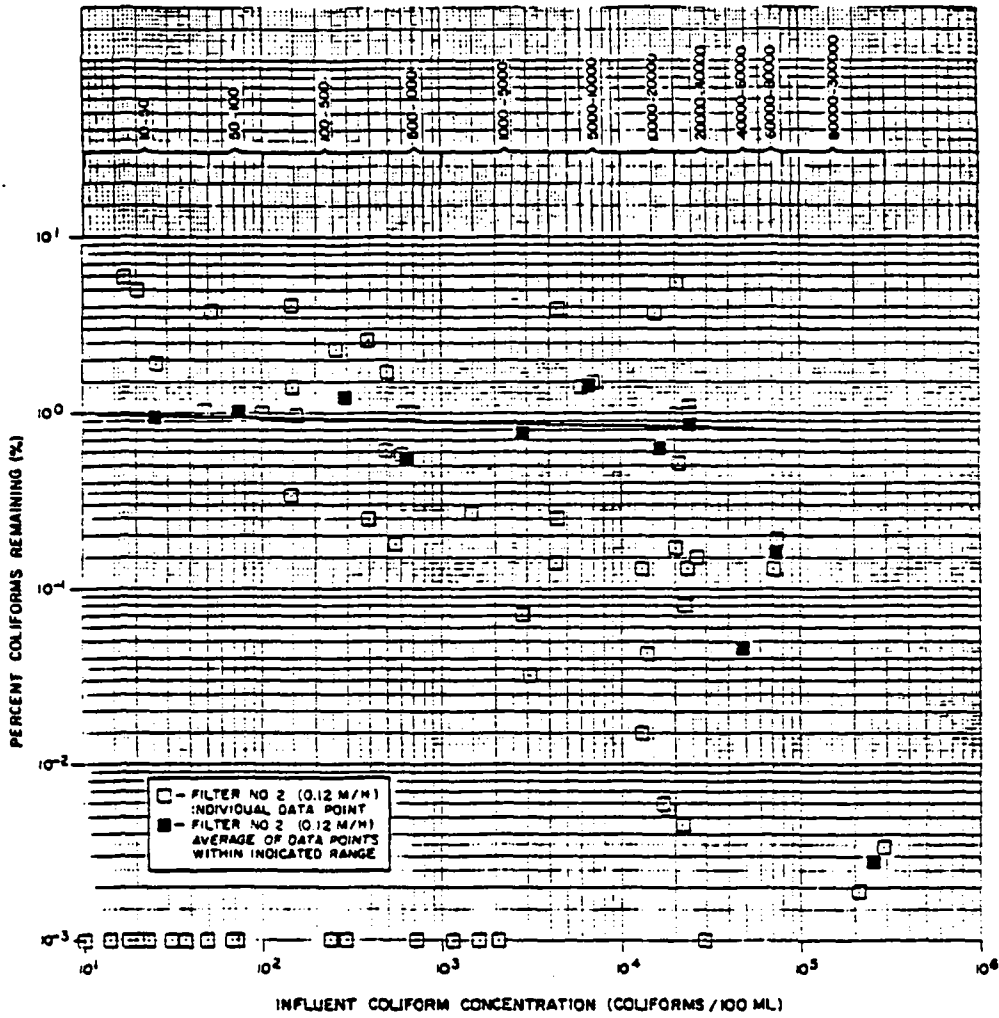

Figure 45. Percent coliform remaining in effluent as affected by influent coliform concentration at hydraulic loading rate = 0.12 m/h.

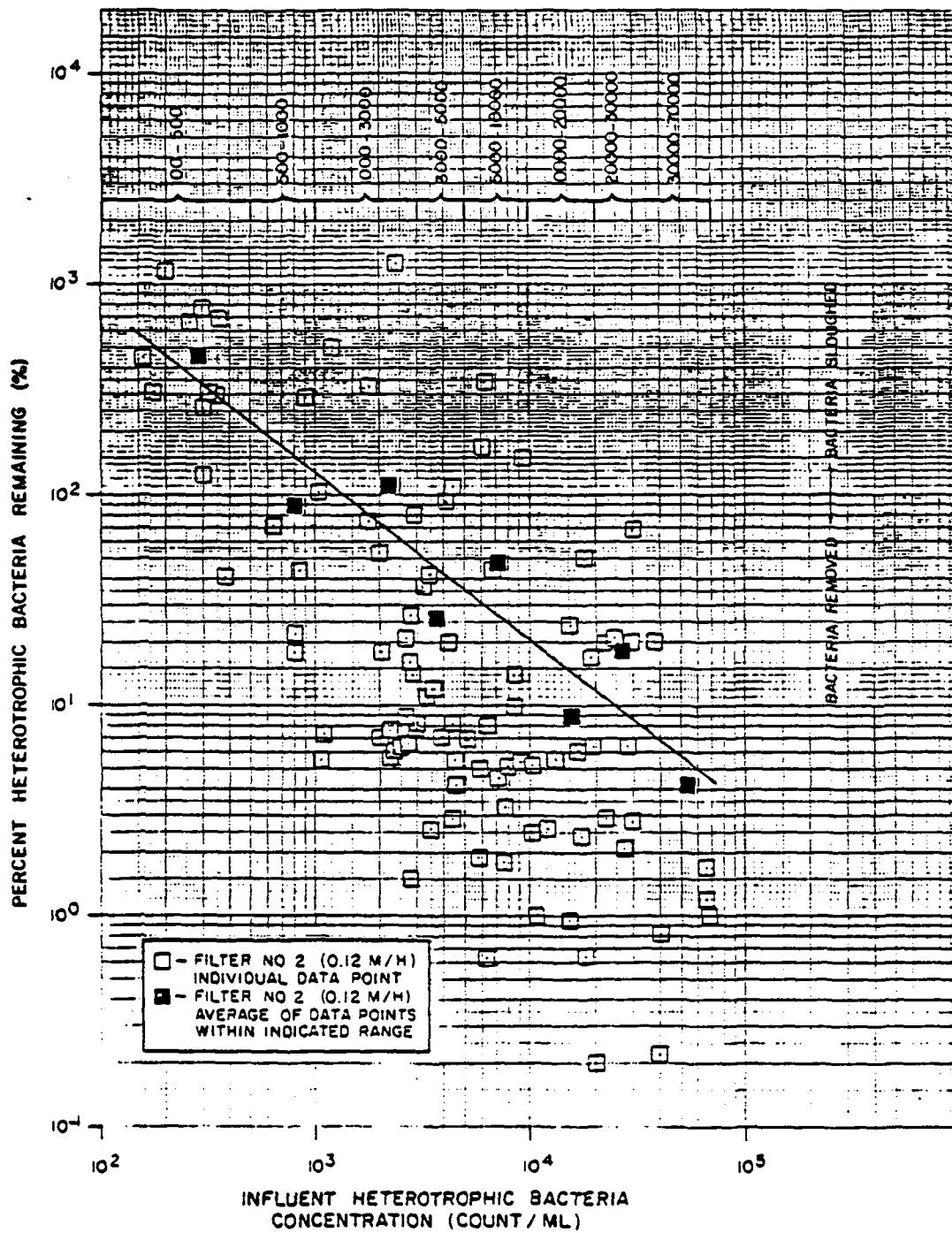

Figure 46. Percent standard plate count bacteria remaining in effluent as affected by influent standard plate count bacteria concentration at hydraulic loading rate = 0.12 m/h.

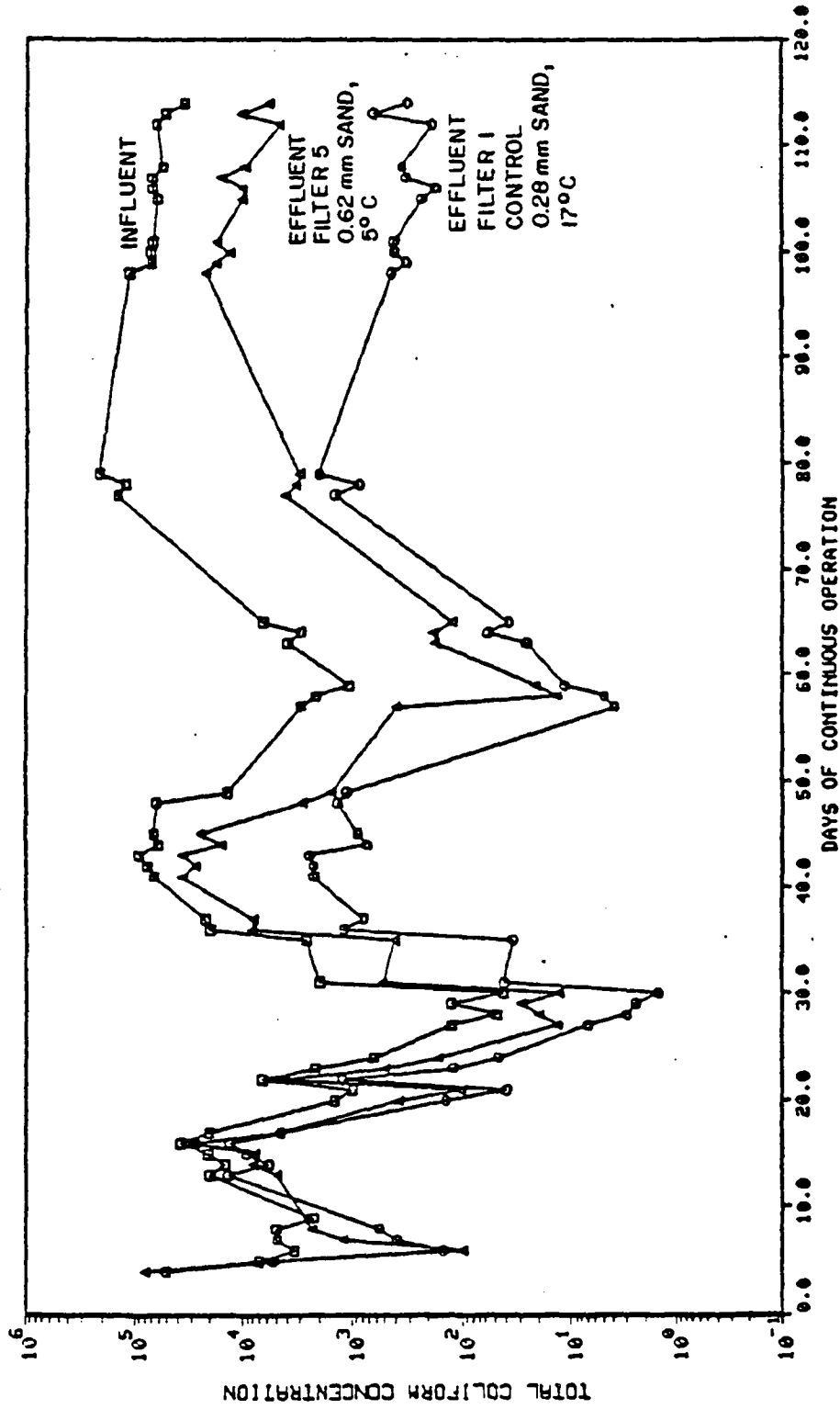
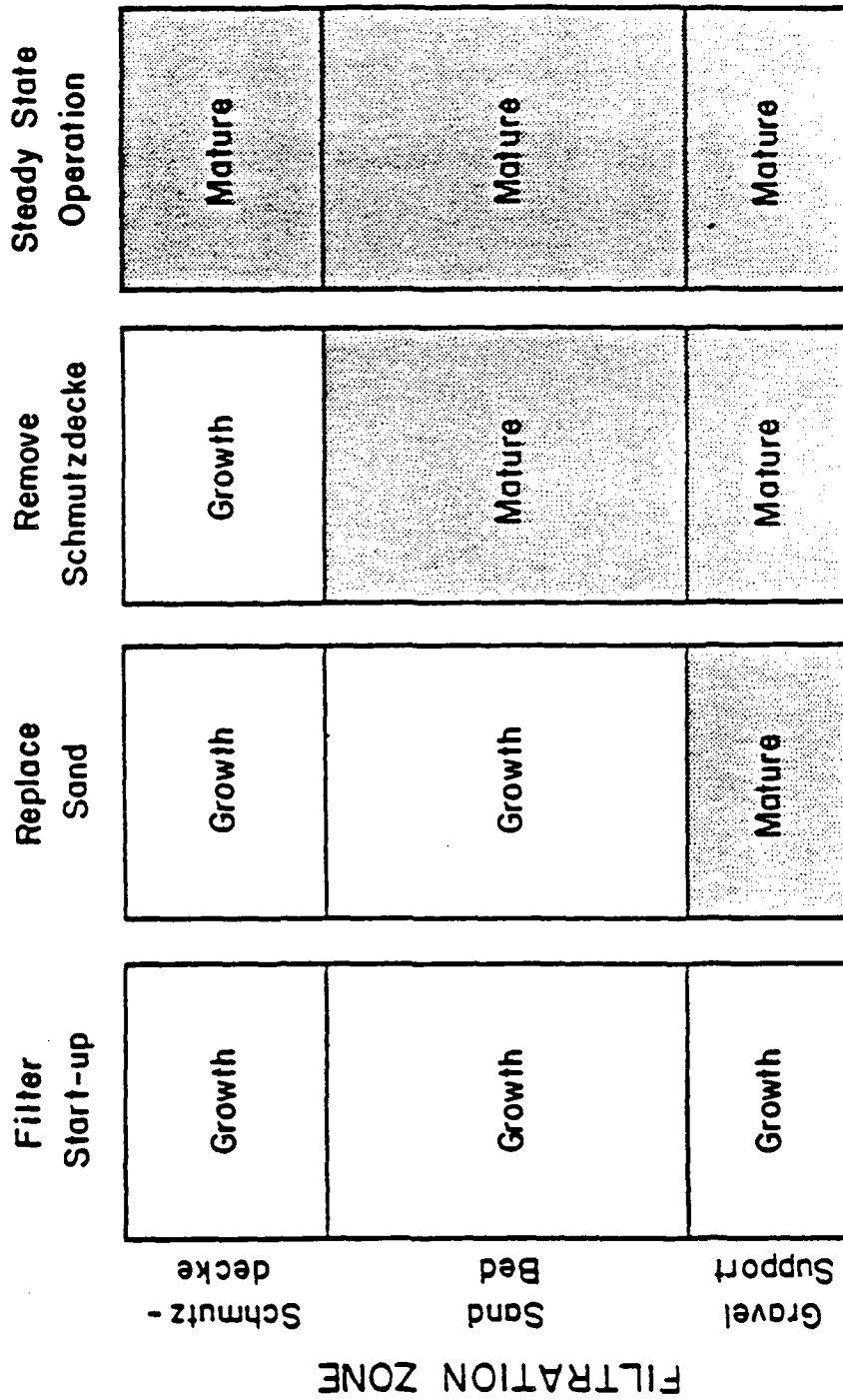

Figure 47. Influent and effluent total coliform concentration for Filter 1 and Filter 5 for the first 115 days of Phase II testing. The influent was common to both filters.

# MODE OF OPERATION



## FILTRATION ZONE

Figure 48. State of the biological community for different modes of operation and at different locations within the filter. Growth refers to the process of establishing a biological community, i.e., biological growth. Mature refers to an established biocommunity, i.e., at steady state.

with the available nutrients. In this state maximum contaminant removal will occur. While the depiction shown in Figure 48 is consistent with our findings quantitative documentation would require further research focused on these particular questions.

To illustrate, Figure 48 shows that during "filter start-up" the biological communities in all three filtration zones are in "growth". By contrast, for "steady state operations" the biological communities are "mature" in all three filtration zones.

#### Filter Start-up—

Figure 49 is a plot of average percent total coliform remaining for start-up and for established operation during the Phase II testing. The plotted points are weekly average values for the first 10 weeks of filter operation. The sloping portion of each plot, except for Filter 4, is a linear regression of the log values for the first few weekly averages. The regression plot Filter 4 used only the first four weeks of data. The horizontal lines, which mark steady state operation with respect to removal, indicate at the same time that the filter sand bed is, by earlier definition, "mature". The plotted points were calculated using 26 analyses obtained between 4 weeks and 10 weeks operation after start-up. The steady state removal lines reflect the effect of the filter test condition on filter performance, i.e., Filter 4, added nutrients, achieved 99.9 percent coliform removal; Filter 1, control, achieved 98 percent removal; Filter 2, one half sand bed depth achieved 96 percent removal; Filter 6, 5°C, achieved 85 percent removal; Filter 5, 5°C and 0.615 mm sand, achieved 83 percent removal; and Filter 3, chlorinated between test runs, achieved 60 percent removal. These percent removals can be calculated from the respective intercepts of the horizontal lines Figure 49 as, 100 minus percent remaining.

From Figure 49, the time to reach steady state operation for Horsetooth water, without nutrient addition, appears to be between 5 and 7 weeks. The trends shown illustrate the differences between the filters. It is clear that the slopes and the times to reach steady state operation, are affected by nutrient availability, temperature, and filter operations.

The plots emphasize the important role of nutrient loading in reaching steady state operation. Filter 4, with nutrient addition, matured in approximately one half the time required by the other filters. Also, the stabilized percent remaining line for mature operation is lower than for any of the other filters and shows the importance of the nutrients in increasing filter efficiency.

The plots show that Filters 1, 2, 5, and 6 matured at approximately the same time. It was expected that the cold filters, 5 and 6, would take longer to mature since their rate of biological development would be slower due to the cold. However, because the steady state removal was less for the cold filters, the rate of biological development did not have to be as great to reach mature operation at the same time as the warm filters.

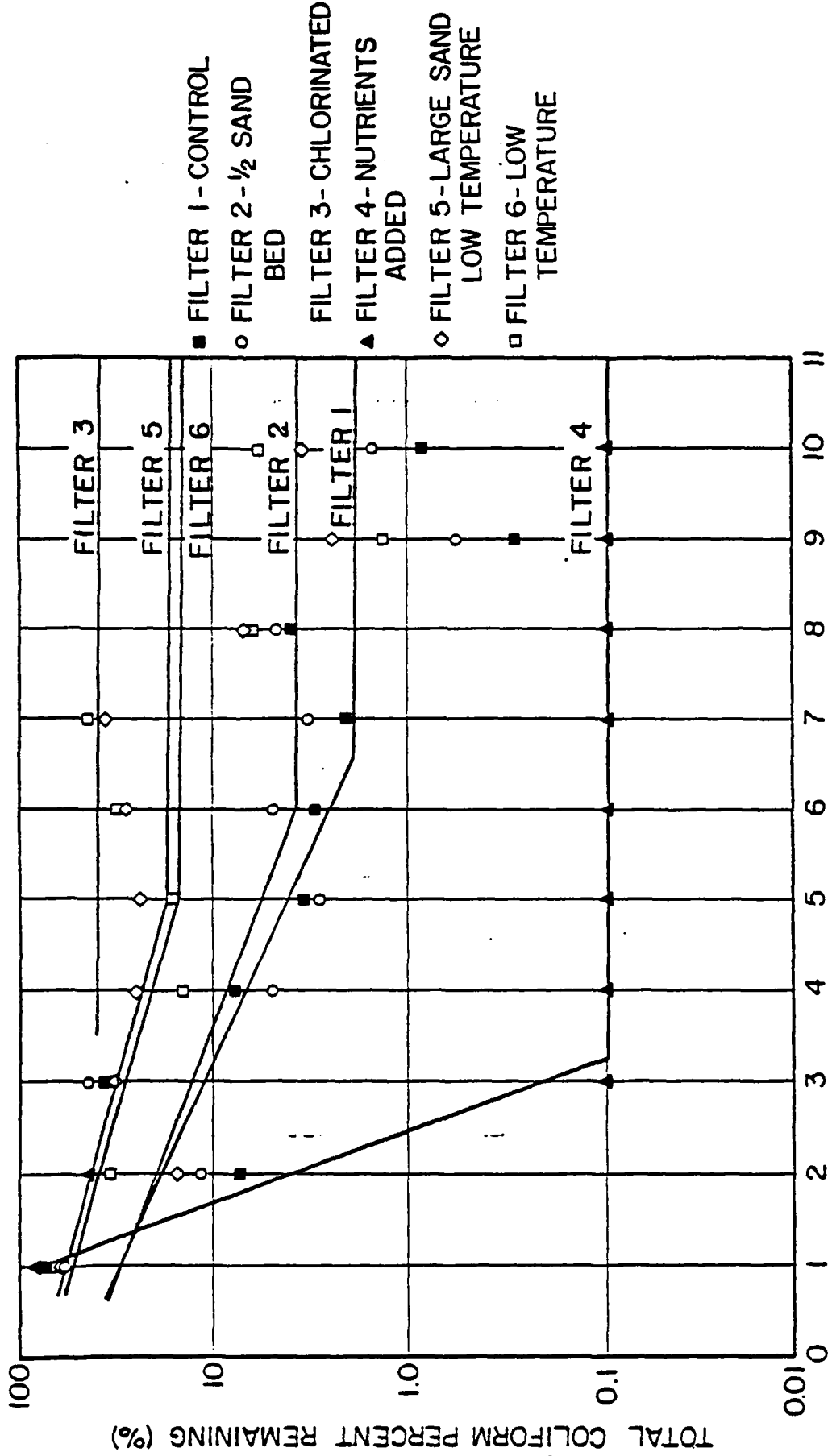

Figure 49. Effect of temperature, sand size, one half sand bed depth, no biological growth, i.e., chlorinated and nutrient addition on filter start-up and mature operation. The plotted points are weekly averages for the first 10 weeks of operation. The curves are least squares fit of start-up data, except for Filter 4 which had only three weeks of start-up and mature operation thereafter. The horizontal lines represent averages of data after "mature" operation. Filter 3 had no change in operating regime and therefore no plot symbol is shown; the horizontal line represents average of all data.

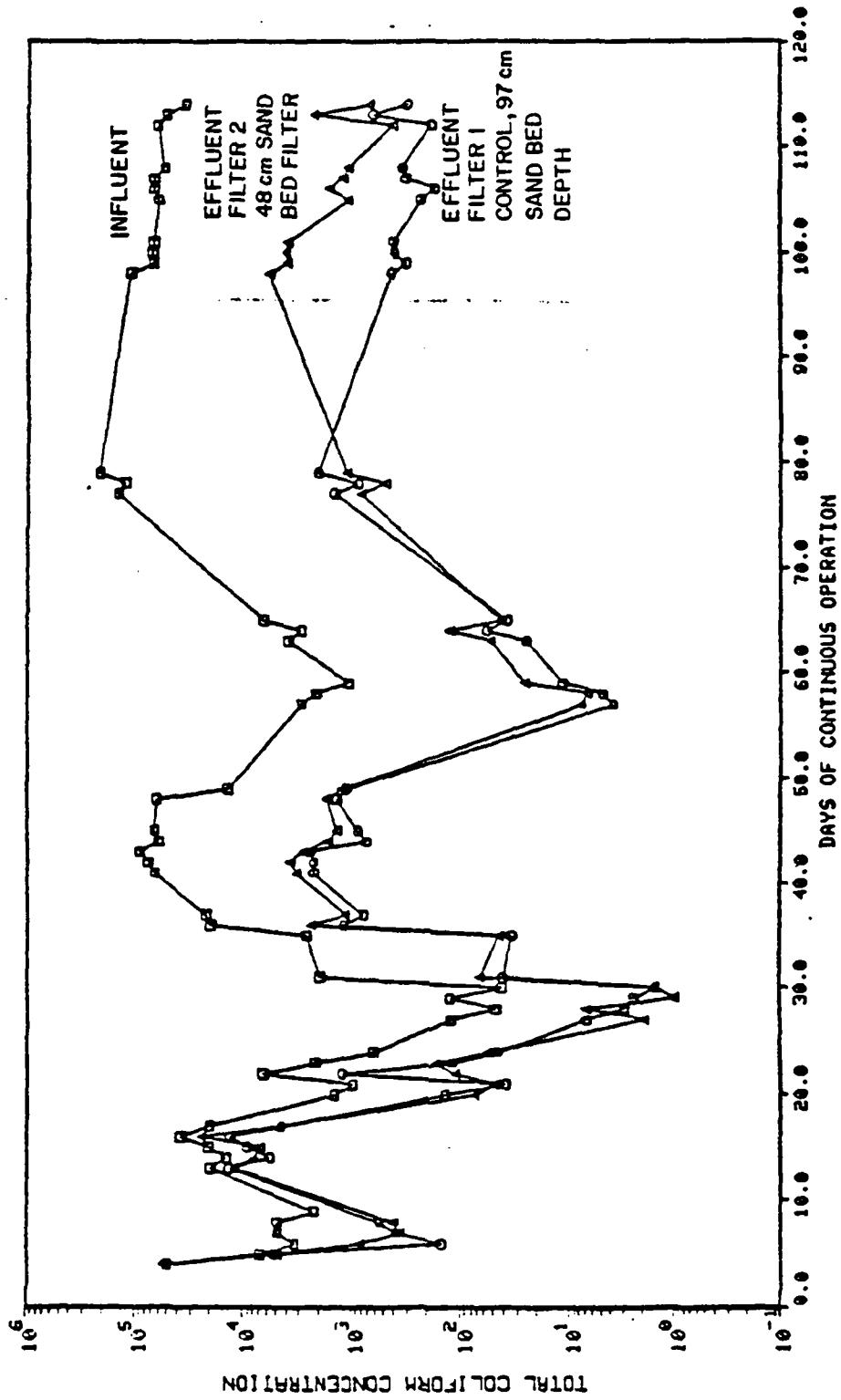

Figure 50. Influent and effluent total coliform concentrations during start-up and for mature operations of Filters 1 and 2, Phase II testing. Filter 1 was the control and Filter 2 had one half the sand bed depth. The plotted values were abstracted from Appendix D.



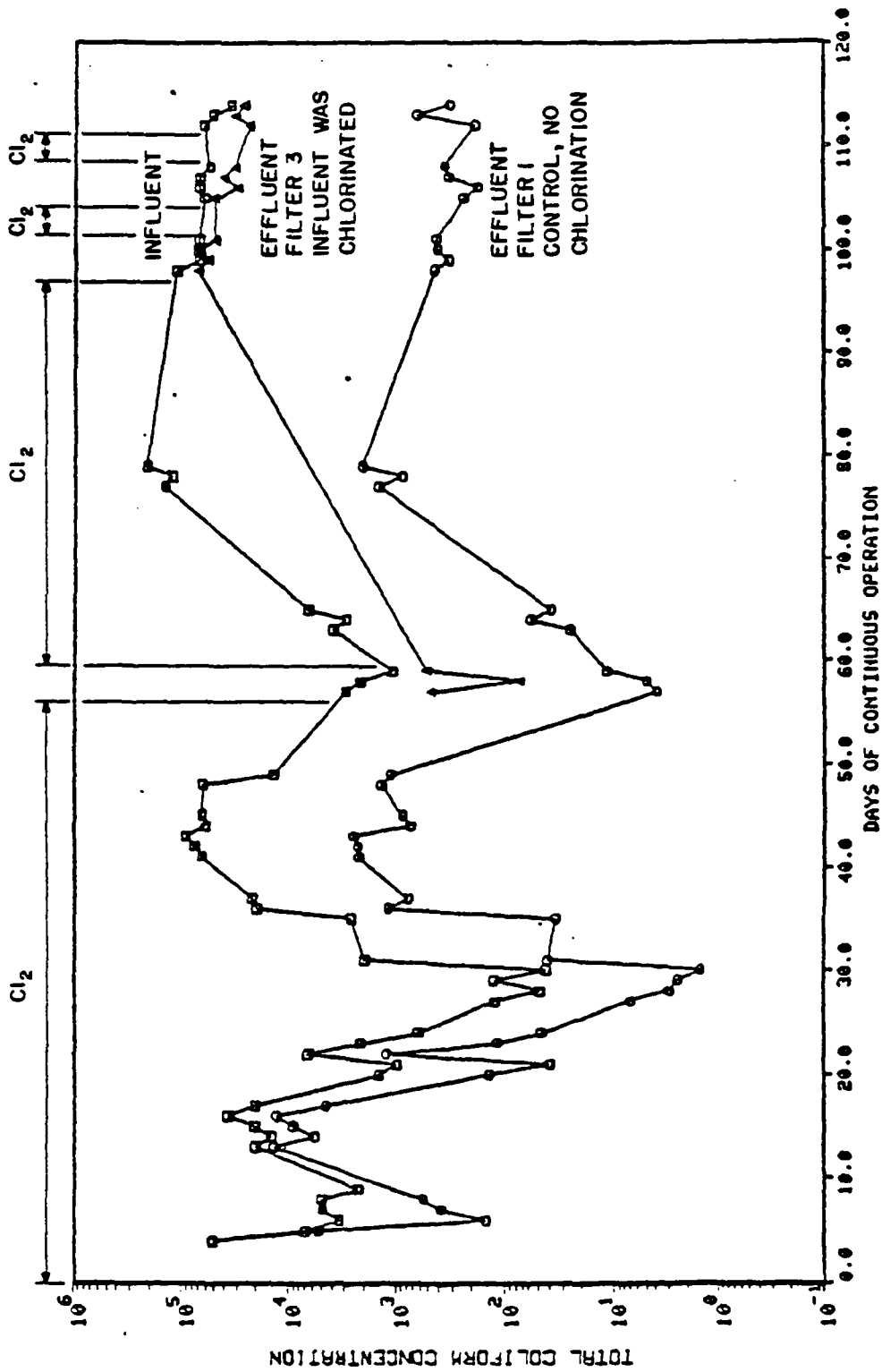

Figure 51. Influent and effluent total coliform concentrations during start-up and for mature operations of Filters 1 and 3, Phase II testing. Filter 1 was the control and Filter 3 was chlorinated between test runs. The plotted values were abstracted from Appendix D.

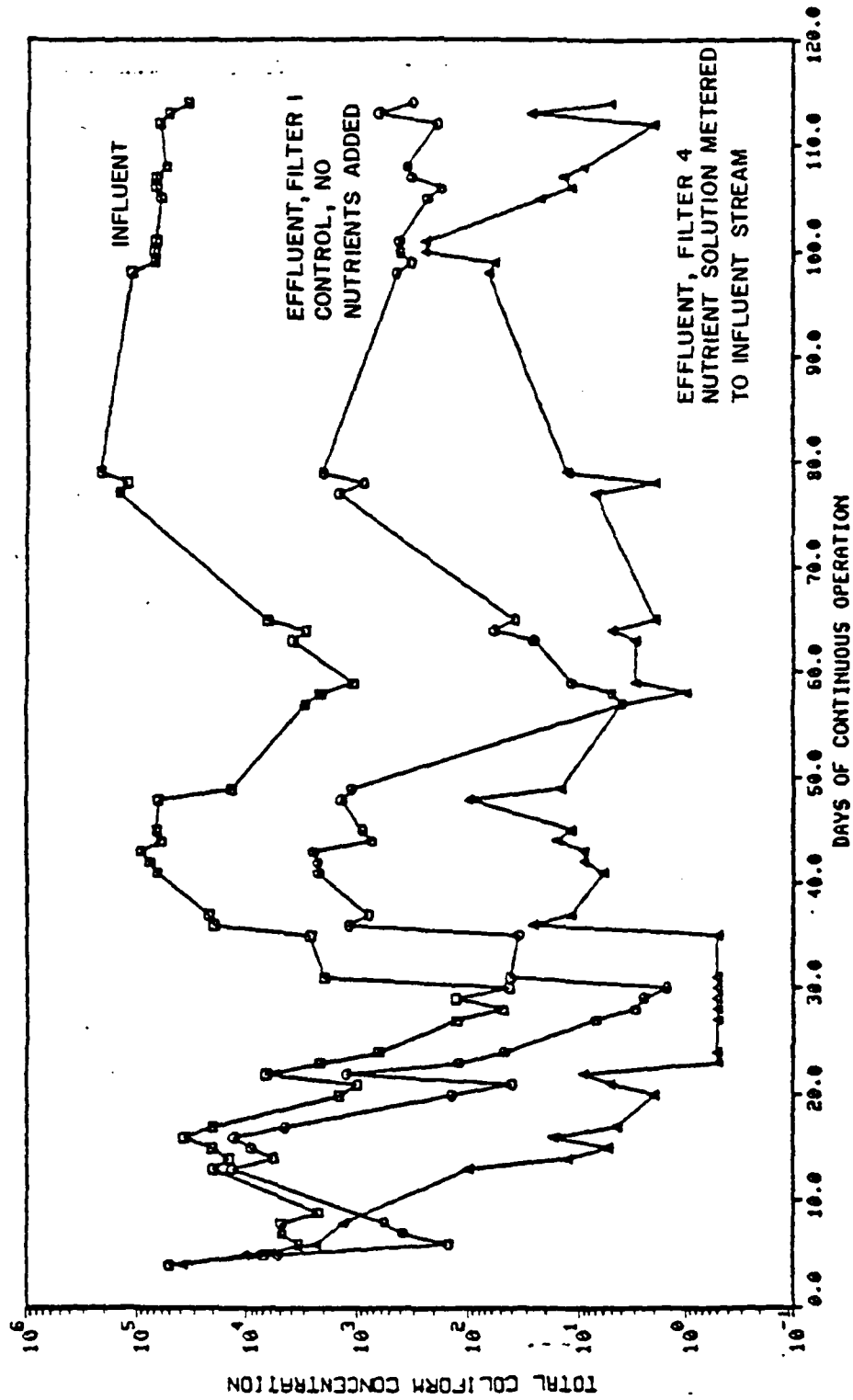

Figure 52. Influent and effluent total coliform concentrations during start-up and for mature operations of Filters 1 and 4, Phase II testing. Filter 1 was the control and Filter 4 had nutrients added. The plotted values were abstracted from Appendix D.

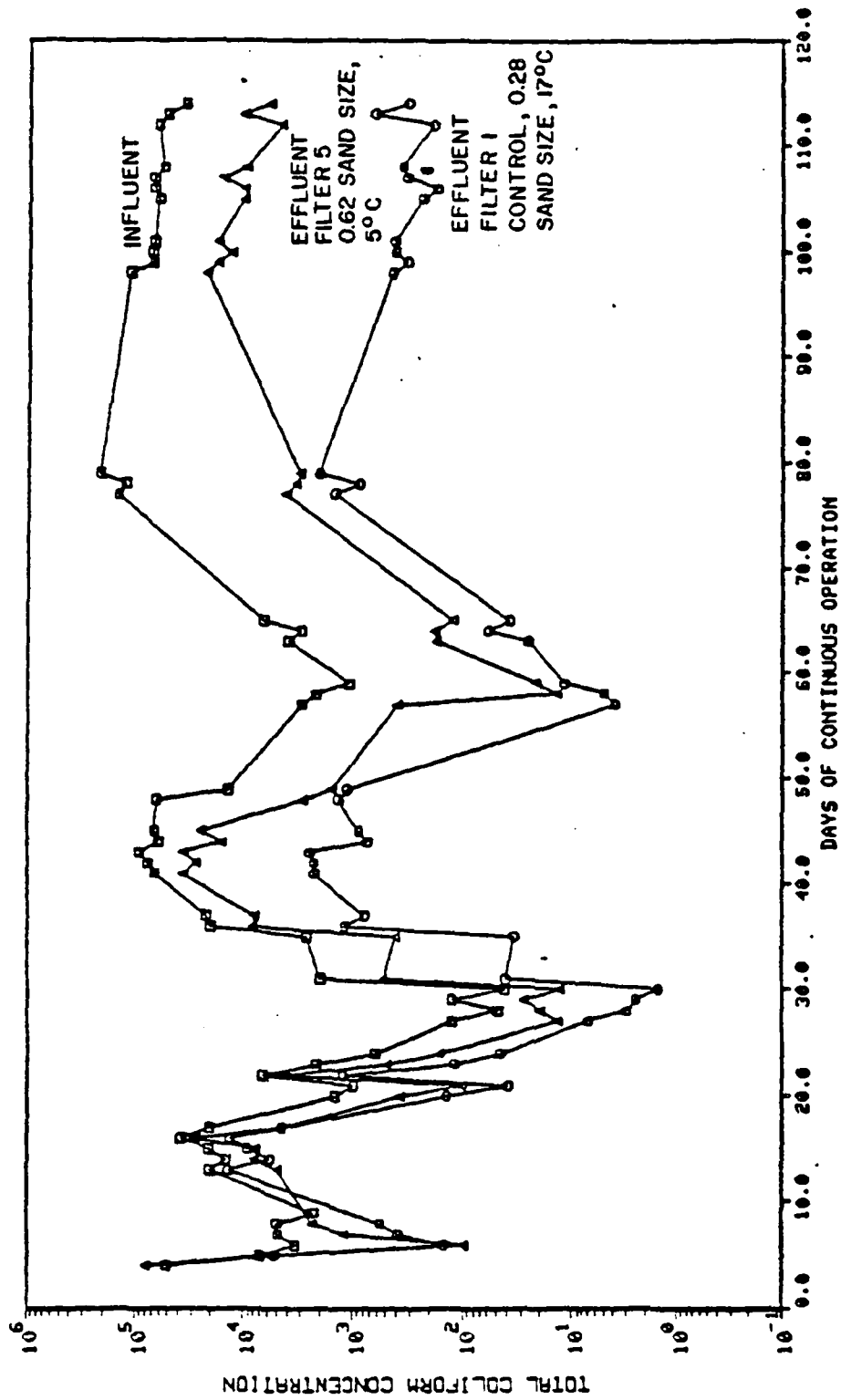

Figure 53. Influent and effluent total coliform concentrations during start-up and for mature operations of Filters 1 and 5, Phage II testing. Filter 1 was the control and Filter 5 had 0.615 mm sand and was operated at 5 C. The plotted values were abstracted from Appendix D.

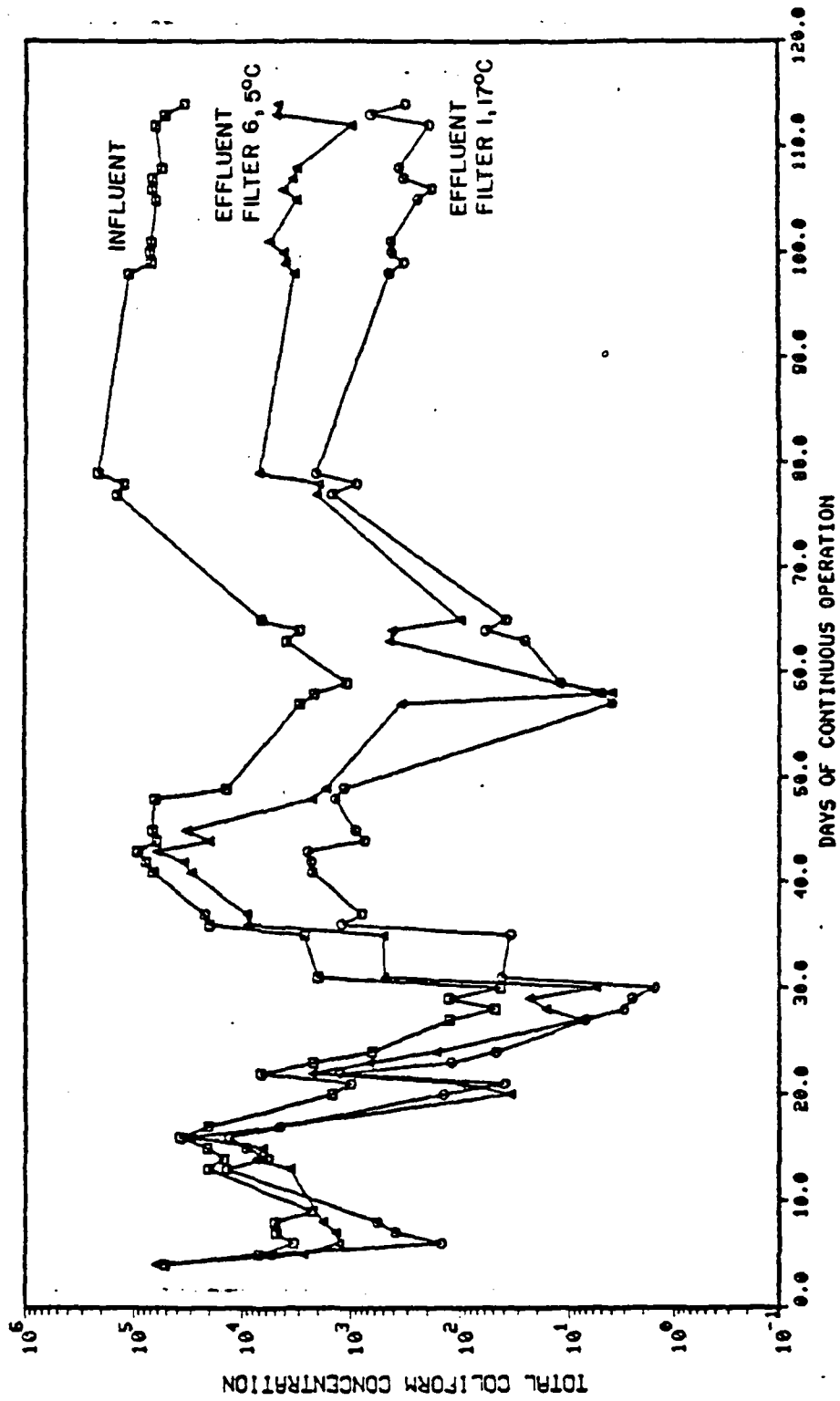

Figure 54. Influent and effluent total coliform concentrations during start-up and for mature operations of Filters 1 and 6, Phase II testing. Filter 1 was the control and Filter 6 was operated at 5°C. The plotted values were abstracted from Appendix D.

Figure 50 through 54 are time series plots of total coliform concentrations for the first 115 days of Phase II operations. Each plot shows the influent coliform concentration history, which was common to each of the six filters, and the effluent concentration history for Filter 1, the control. Figure 50 shows, in addition, the effluent coliform concentration over time for Filter 2, which had one half the sand bed depth. Figure 51 shows the effluent concentration for Filter 3, which was chlorinated between test runs. Figure 52 shows the same for Filter 4, which had nutrients added. Figure 53 shows the same for Filter 5, which was operated at 5°C with 0.618 mm sand. Figure 53 shows the effluent coliform concentration for Filter 6, which was operated at 5°C. For each plot, the start-up period is indicated by the improvement in percent removal, illustrated by an increase in separation between the influent and effluent plots i.e., day 0 to approximately day 50,. These results also confirm the effect of time on the development of a biological population and on filter effectiveness. The respective filter performances as depicted by the concentration time histories are similar to the comparisons shown in the plots of Figure 49.

Figure 49 summarizes the outcomes of the six filters each operated with one variable differing in magnitude. Compared with the control, Filter 3, the chlorinated filter, had the highest percent remaining of total coliform removal, e.g. about 50 percent, vis a vis 2 percent. This was expected, of course, if the internal biopopulation is as important as hypothesized. By comparison, Filter 4, which had nutrients added, had only 0.1 percent remaining. These results show that the internal biopopulation does indeed have a most important role in the rapid rate filtration process.

The roles of sand bed depth, temperature, and sand size are indicated also in Figure 49. With large sand ( $d_{10} = 0.62$  mm) operated at 5°C temperature, percent remaining was about 20 percent, while the percent remaining for the  $d_{10} = 0.28$  mm sand was still only about 18 percent when operating at 5°C. Filter No. 2 having a bed depth of only 48 cm (vis a vis 97 cm for the control) still had only about 5 percent total coliform remaining, which is significant in terms of how much the sand bed can be removed by scraping and have high removal efficiency.

Figures 55 and 56 are time series plots of influent and effluent turbidity analyses for Filters 1 and 4 the control filter and the nutrient added filter, respectively. As shown, the turbidity removal improved from day 0 to approximately day 50 in the same manner as the coliform removal improved in Figures 50 through 53. But more importantly, Filter 4 with the nutrients added showed remarkably lower effluent turbidities than the control filter, e.g. 6.5 NTU raw water to about 2.5 NTU effluent vis a vis 6.5 NTU to 4 NTU, respectively. This provides evidence that turbidity removal for Horsetooth Reservoir water is influenced by the same mechanisms of removal as coliforms. If the surfaces of the sand particles are coated with bacterial films, it is quite likely these surfaces are "sticky" and will retain particles which impinge upon them as a result of transport by convection and diffusion along the tortuous path during filtration. Further it is quite possible that the bacteria have natural polymers which could coagulate some of the clays entering the biofilms on the sand.

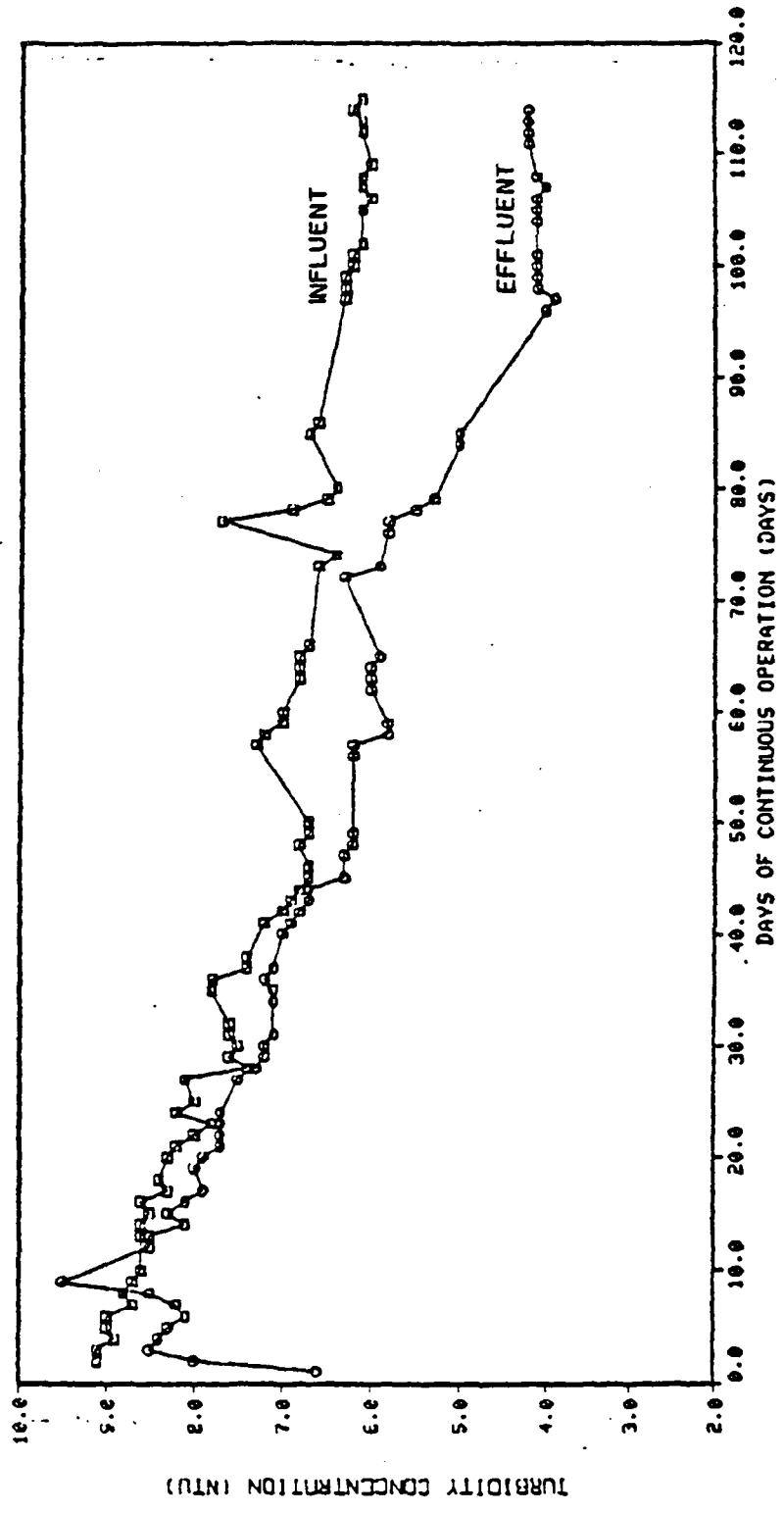

Figure 55. Improved turbidity removal over time for Filter 1, Phase II testing. Filter 1 is the control filter.

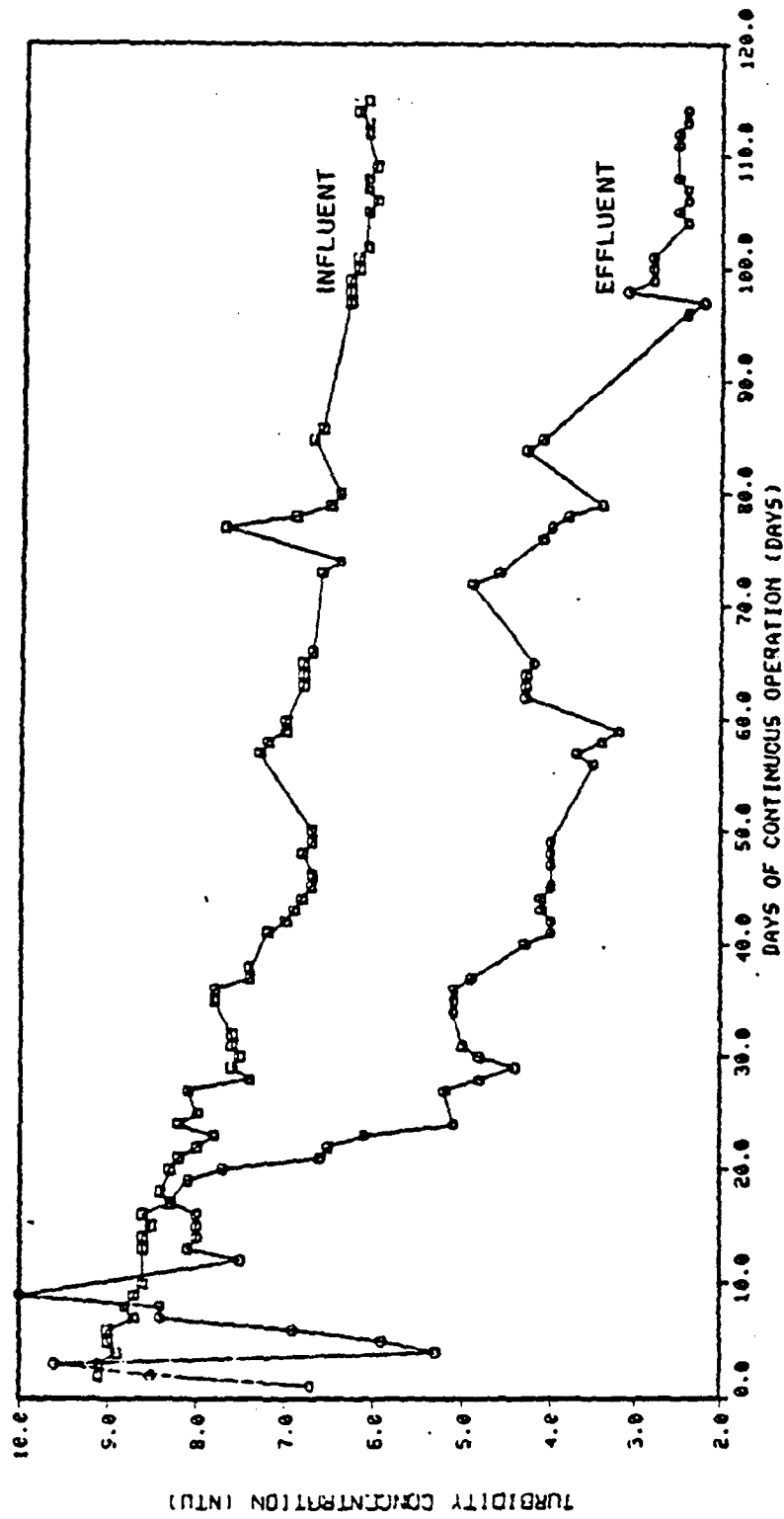

Figure 56. Improved turbidity removal over time for Filter 4, Phase II testing. Filter 4 had nutrients added.

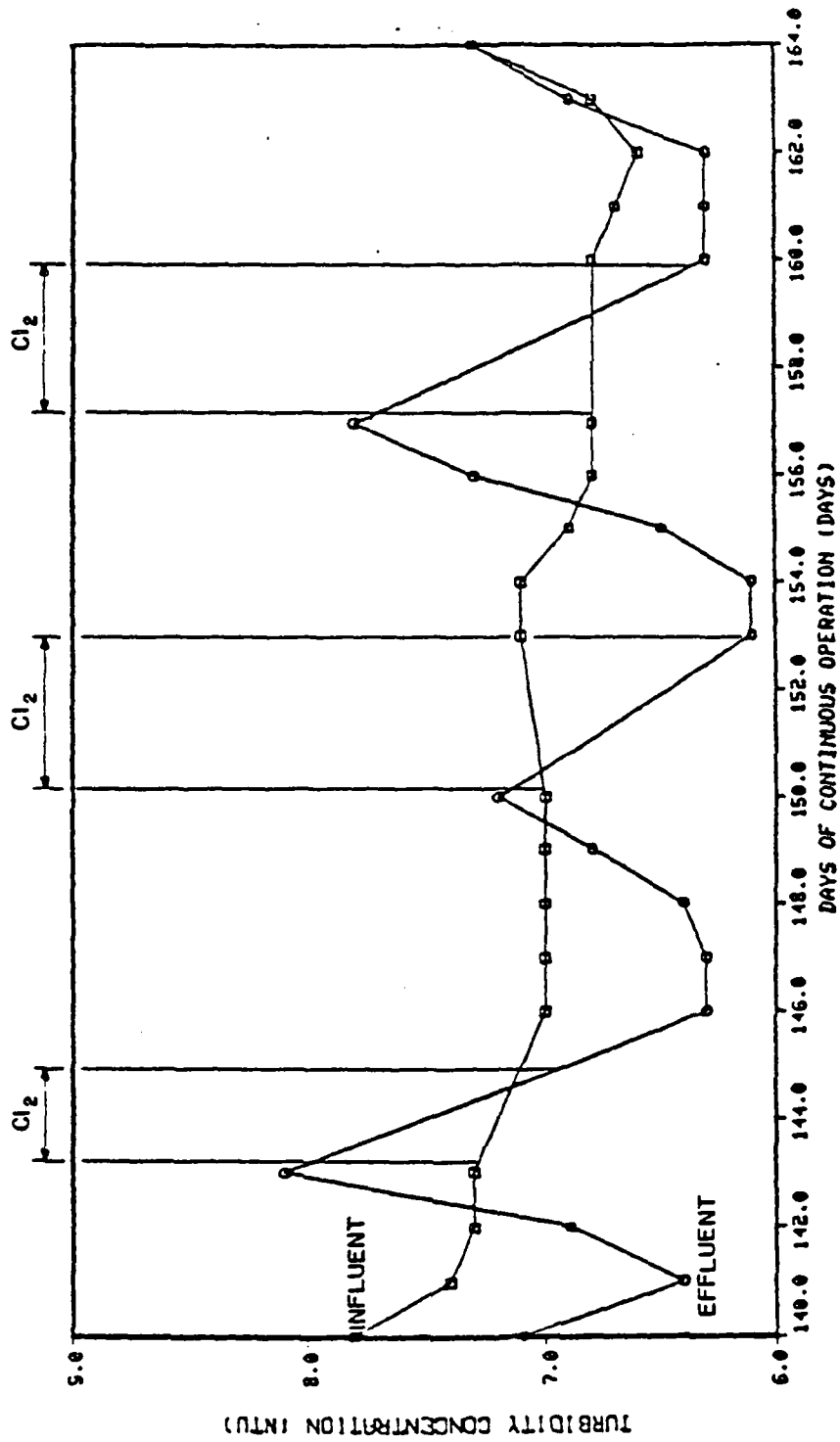

Figure 57. Influent and effluent turbidity concentration for Filter 3. Sodium hypochlorate at mg/L was metered to this filter continuously except during test runs. Plot demonstrates increase in turbidity after each chlorination and dechlorination of the filter.



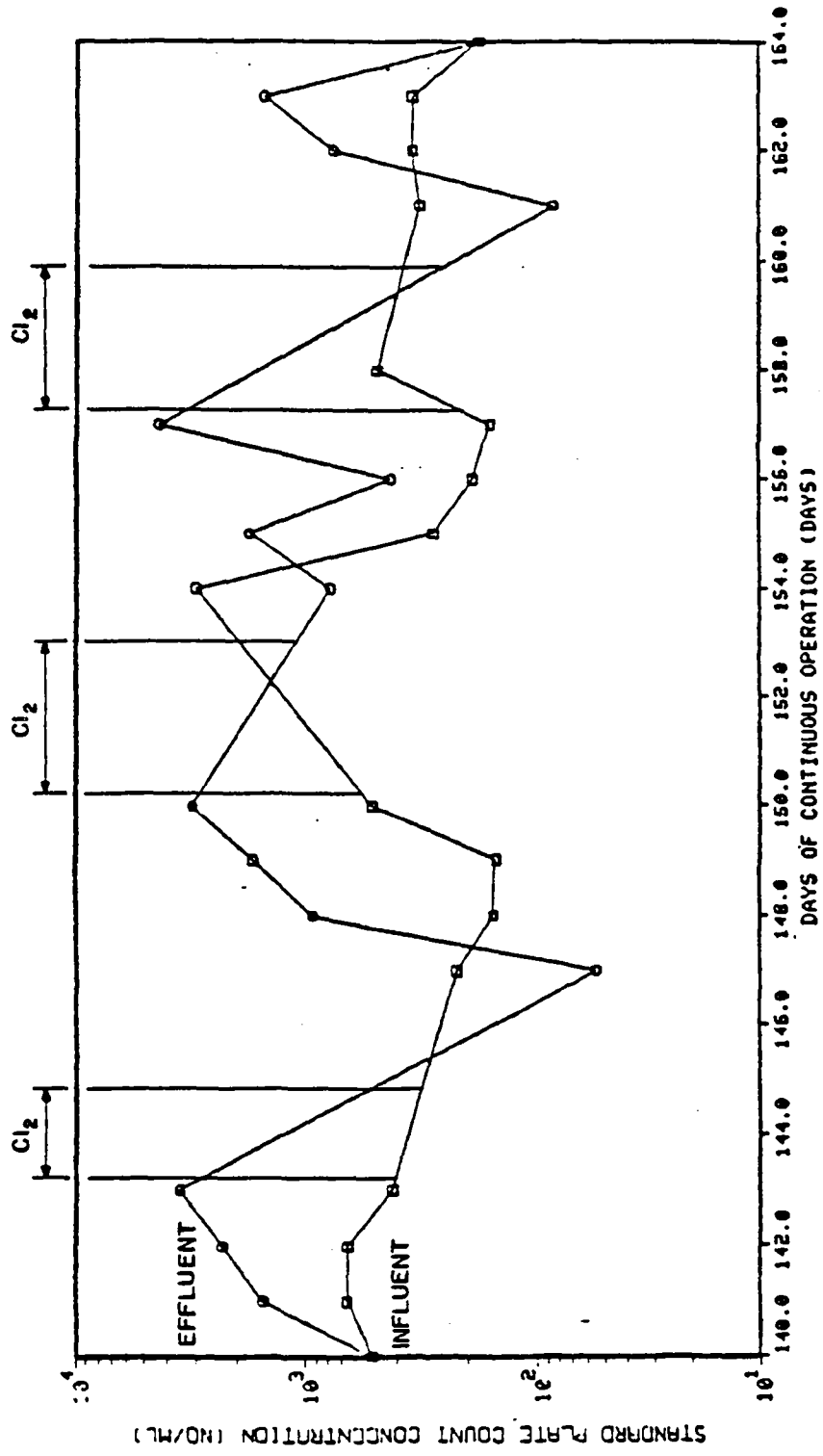

Figure 58. Influent and effluent standard plate count bacteria concentrations for Filter 3. Plot demonstrates the increase in SPC bacteria after each chlorination and dechlorination of the filter.

The initial days of start-up were also analyzed with results from Filter 3, Phase II, which was chlorinated between periods of analyses. The filter was dechlorinated with sodium thiosulfate 24 hours prior to biological analyses. This provided a filter in the "start-up mode" for repetitive testing periods. Figures 57 and 58 are time series plots of influent and effluent turbidity and standard plate count bacteria analyses for Filter 3. The influent data for the standard plate count were displaced 24 hours to compare influent and effluent analyses. These results show four different "start-ups" after chlorination. For each case the turbidity and standard plate count started below the influent level and then increased above the influent level. If the filter was not further dosed with disinfectant these negative removals would have been overcome within another week and the removal steadily improve as demonstrated by Figure 50 through 54.

Table 25 shows the Giardia removal capabilities of a filter in the start-up mode compared to a filter which has been in continuous operation for 80 weeks. The filters were operated in parallel with identical influents.

Table 25. Giardia removal as effected by a filter in the start-up mode of operation versus a filter with a mature biopopulation. Phase I results.

Filter Condition	Run No.	Hydraulic Loading Rate (m/hr)	Length of Filter Operation (weeks)	Influent Cyst Conc. (c/L)	Effluent Cyst Conc. (c/L)	Percent Removal <sup>1/</sup> (%)
New sand	118	0.40	0	2000	17	99.2
Mature Biopop.	119	0.40	80	2000	0	100

<sup>1/</sup>Qualified by the detection limits shown in Table 4-18.

For this test the filter with a mature biological population was capable of removing all of the Giardia cysts, i.e., to the detectable limit. Probably the cysts are adsorbed by adsorption on the biological film attached to the sand grains, and then, it is speculated, they are metabolized by these organisms. The filter with new sand allowed 17 cysts per liter to pass from an influent of 2000 cysts per liter. This demonstrates that a filter in the start-up mode will not remove all of the influent Giardia cysts while a filter with a mature biopopulation will do so. It shows also that a new filter is still capable of removing approximately 99 percent of the Giardia cysts. Adsorption to the sand grains and straining must be the removal mechanisms for the new sand.

Figure 59 shows the effect of the four modes of filter operation on effluent coliform concentrations, i.e., percent remaining at hydraulic loading rates of 0.04, 0.12 and 0.40 m/hr. The effectiveness of a filter during start-up, can be seen by comparing the bar for that condition, Run 118, with those for the other modes of operation. Run 118 shows that percent total coliforms in the effluent is higher in the start-up mode than for any other condition of operation. The mature filter, Run 106, had only 0.4

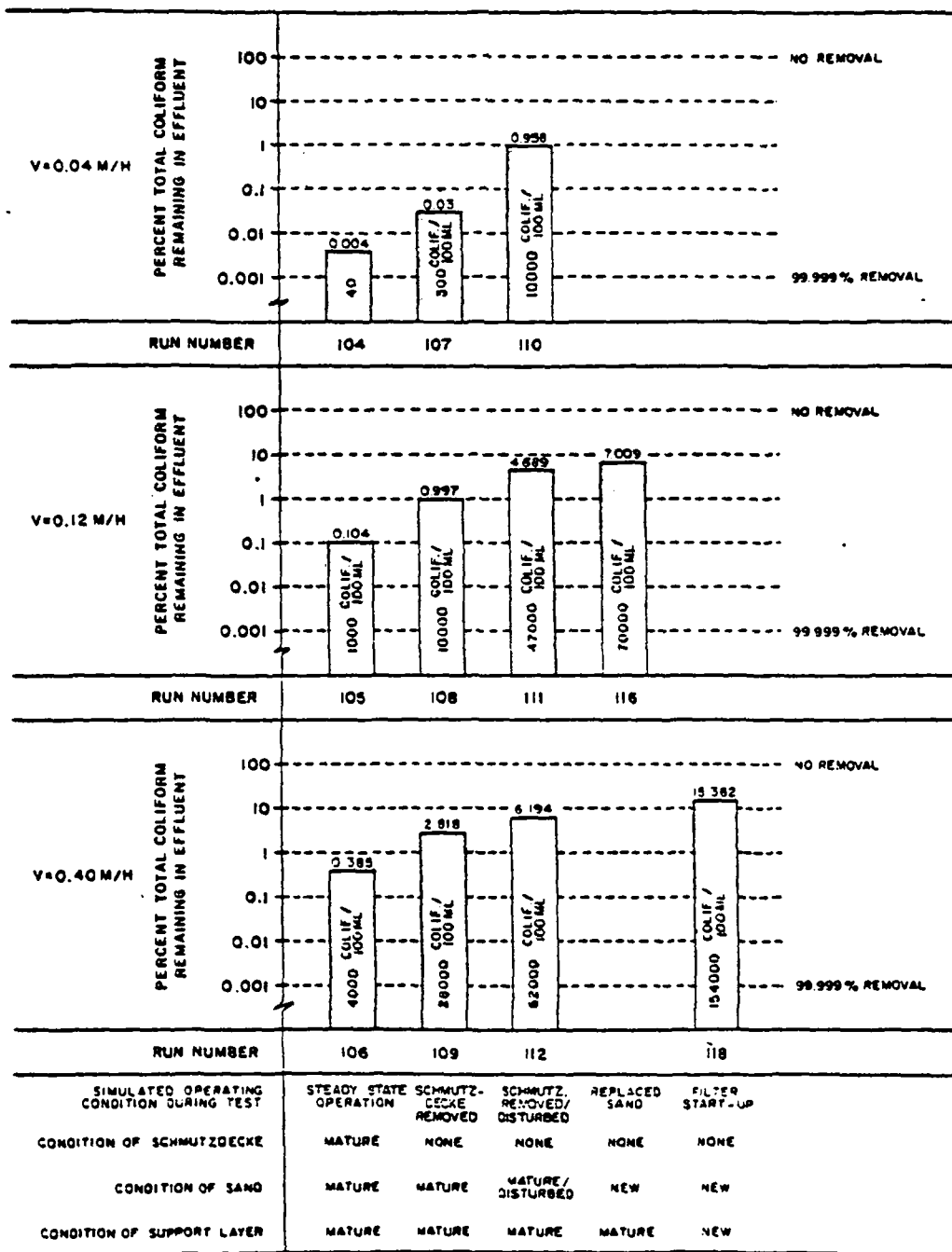

Note: Quantities shown within each of the "bars" are effluent coliform concentrations calculated from a hypothetical influent density of one million coliforms per 100 mL. Percent remaining are calculated from data abstracted from Appendix D, for each of the test runs sited.

Figure 59. Effect of conditions of schmutzdecke and sand bed on percent remaining of total coliforms for three hydraulic loading rates.

percent coliforms remaining while the filter during start-up had 15.4 percent coliforms remaining. Put another way, if the influent total coliform concentration was hypothetically one million coliforms per 100 mL, a mature filter would have only 4000 coliforms/100 mL in the effluent while a start-up filter would have 154,000 coliform/100 mL.

Table 26 shows that replacing sand had no effect on *Giardia* removal for the test runs indicated. The filter with replaced sand, it should be noted, had a "mature" gravel support layer which had been in operation 67 weeks. The gravel support was not disturbed when the sand was replaced. While perhaps in retrospect we should have found some way to scrape the surface of the gravel particles and plate the suspensions, standard procedures are not available to evaluate biological films, and this was not done. Nevertheless there can be little doubt that if a biological film was present on the sand particles, it had to exist also on the gravel.

Table 26. Effect of sand replacement on *Giardia* cyst removal.

Filter Condition	Run No.	Hydraulic Loading Rate (m/hr)	Length of Operation (weeks)	Influent Cyst Conc. (c/L)	Effluent Cyst Conc. (c/L)	Percent Removal (%) <sup>2/</sup>
Replaced sand on mature gravel support	116	0.12	0 <sup>1/</sup>	3692	0	100
Mature (control)	117	0.12	67	3692	0	100

<sup>1/</sup>The gravel support layer had been in continuous operation for 67 weeks.

<sup>2/</sup>Qualified by the detection limits shown in Table 30.

Comparing the results of Run 116 with those of Run No. 118, which had both new sand and new gravel support, i.e., "start-up" condition, it is seen that the filter with the mature gravel support removed the cysts which passed a new sand bed. This indicates that even the modest amount of microbiological growth in the gravel support can provide the marginal effect required to cause cyst removal to approach 100 percent.

The role of a mature gravel support is illustrated further in Figure 59. It shows that replacing sand with a mature gravel support remaining, as in Run 116, will permit as much as 7 percent coliform bacteria remaining compared with 0.1 percent for a mature filter, as in Run 105.

From these results it can be inferred that removal of Giardia cysts will remain near 100 percent, even after the operation of replacing sand, if a mature gravel support remains in place. The coliform removal results, however, show that a significant decrease in filter efficiency occurs after sand replacement.

**Schmutzdecke Removal—**

It is established practice that the schmutzdecke is removed when the headloss exceeds the maximum design values of 1 to 1.5 meters. Schmutzdecke removal is described in a previous section.

Table 27 shows the results of 15 Giardia test runs for filters with freshly scraped sand surfaces, i.e., no schmutzdecke. These test runs are listed in order of the number of weeks of continuous filter operation, which ranged from 26 to 70 weeks. The table shows that removal of Giardia cysts to below the detection limit was achieved in all but four of these test runs. The key difference between those tests which achieved complete removal and those that did not was the degree of microbiological maturity within the sand bed and not the fact that the schmutzdecke had been removed. All four of the tests in which cysts were passed occurred during the first 41 weeks of filter operation. After this period, when the microbiological population had developed to "maturity", complete removal of Giardia cysts occurred. Also, Table 27 shows that this occurs independent of hydraulic loading rate, influent Giardia cyst concentration, and presence of a schmutzdecke.

Table 27. Giardia removal by slow sand filtration as affected by schmutzdecke removal. Each of these tests were conducted within one day of removing the schmutzdecke.

Run No.	Hydraulic Loading Rate (m/h)	Length of Operation (weeks)	Influent Cyst Conc. (c/L)	Effluent Cyst Conc. (c/L)	Percent Removal (%)
48	0.04	26	420	2.014	99.520
49	0.40	26	420	5.431	98.707
47	0.12	33	420	1.541	99.633
75	0.04	41	50	0.000	100.000
76	0.40	41	50	0.002	99.996
81	0.04	45	50	0.000	100.000
82	0.40	45	50	0.000	100.000
74	0.12	48	50	0.000	100.000
80	0.12	52	50	0.000	100.000
107	0.04	62	1500	0.000	100.000
109	0.04	62	1500	0.000	100.000
100	0.04	63	1953	0.000	100.000
112	0.40	63	1953	0.000	100.000
108	0.12	69	1500	0.000	100.000
111	0.12	70	1953	0.000	100.000

<sup>1/</sup> Qualified by detection limits shown in Table 30.

Figure 59 shows the effect of schmutzdecke removal on percent total coliforms remaining in filter effluent. The bar graphs comparing Runs 104, 105, 107 with Runs 107, 108, 109, respectively, show that schmutzdecke removal will result in approximately a 10 times, i.e. one log, decrease in treatment efficiency when compared to operation under steady state.

Schmutzdecke removal followed by the disturbance of the sand bed was also investigated, as illustrated by runs 110, 111 and 112. This experiment was intended to simulate the effects of a full-scale filter operation in which the filter is drained and the sand bed is disturbed by the movement of men and equipment over the filter surface during schmutzdecke removal. The experimental disturbance was accomplished for each filter by: draining the filter for a two day period, removing the schmutzdecke, mixing the top 10 centimeters of sand, and pounding on the sand surface. This experiment caused an additional 5 to 10 times decrease in treatment efficiency compared with the schmutzdecke removal procedure when no disruption occurred.

To summarize, the Giardia results show that schmutzdecke removal will not affect cyst removal. Coliform results indicate however, that filter efficiency does deteriorate by 10 to 100 times immediately after schmutzdecke removal. Because of this, filtering to waste for one to two days after removing the schmutzdecke is recommended by the World Health Organization. While we have the feeling based upon this work that the filter will still produce acceptable effluent if this is not done, its use as a precautionary measure could be advisable. This would provide time also for the biological population within the sand bed to recover also, in event the scraping period has caused some determination.

#### Steady State Operation—

Steady state operation occurs when the biological population is mature throughout the filter. At this stage maximum contaminant removal can be expected.

Figure 49 shows that the greatest total coliform removal occurs when operation is steady state, i.e., the sand bed is "mature". This is demonstrated by runs 104, 105 and 106 in Figure 39 which display better treatment efficiency than any other mode of operation. This figure shows also that treatment efficiency will deteriorate markedly as greater portions of the biological community are disrupted.

Table 28 shows Giardia cyst removal results for 24 test runs with established schmutzdeckes, listed in chronological order. These results demonstrate that the removal of cysts improved steadily with time and was independent of schmutzdecke age, hydraulic loading rate, or influent cyst concentration. Cysts passed through filters with 12 week old schmutzdeckes while they were removed to below the detectible limit with four to five week old schmutzdeckes when the microbiological population within the filter was given a longer time to mature. In fact, after 49 weeks of operation, cyst removal to below the detection limit was achieved in all cases, even with influent cyst concentrations as high as 5,075 cysts/liter. These results

Table 28. Giardia removal by slow sand filtration as effected by the maturity of the biological population. Tests with established schmutzdeckes.

Run Number	Hydraulic Loading Rate (m/h)	Length of Time in Operation (weeks)	Age of Schmutz-decke (weeks)	Influent Cyst Concentration (c/L)	Effluent Cyst Concentration (c/L)	Percent Removal <sup>1/</sup> (c/L)
54	0.04	29	3	500	0.305	99.939
55	0.40	29	3	500	0.387	99.923
60	0.04	31	5	500	0.000	100.000
61	0.40	31	5	500	0.111	99.978
53	0.12	36	3	500	0.140	99.972
59	0.12	38	5	500	0.035	99.993
66	0.04	38	11	50	0.050	99.900
67	0.40	38	2	50	0.011	99.978
69	0.04	39	12	50	0.114	99.772
70	0.40	39	12	50	0.017	99.966
65	0.12	45	11	50	0.016	99.968
68	0.12	46	3	50	0.041	99.918
87	0.04	49	4	1000	0.000	100.000
88	0.40	49	4	1000	4.373	99.863
90	0.04	50	5	1000	0.000	100.000
91	0.40	50	5	1000	0.000	100.000
86	0.12	56	4	1000	0.000	100.000
89	0.12	57	5	1000	0.000	100.000
101	0.04	60	16	1087	0.000	100.000
103	0.40	60	16	1087	0.000	100.000
104	0.04	61	17	5075	0.000	100.000
160	0.40	61	17	5075	0.000	100.000
102	0.12	67	16	1087	0.000	100.000
105	0.12	68	17	5075	0.000	100.000

<sup>1/</sup>Qualified by detection limits shown in Table 30.

and those shown in Table 16 demonstrate that the maturity of the microbiological population in the sand bed is the most important factor in cyst removal.

**Biological Community Importance—**

To further assess the importance of the biological community, Filter 3 and 4, Phase II testing, were operated under continuous disinfection and with augmented biological activity, respectively. Disinfection of Filter 3 between test runs was done to prevent a biological community from developing in the filter. For Filter 4 nutrients were added as a sterile synthetic sewage, as formulated by Piper (1962), see Appendix P. The nutrient addition caused a decrease in dissolved oxygen across the filter of 3 to 4 mg/L. The synthetic sewage had a BOD of approximately 5 mg/L according to Piper's calculations.

Table 29 shows the results of these test runs. Total coliforms bacteria, standard plate count bacteria, and turbidity were all improved by increasing the level of biological activity. Percent removals for Filter 4, with the nutrient addition, were 99.9, 58, and 52, respectively, compared to 60.1, -89, and 5, respectively for the disinfected filter.

Table 29. Effect of the biological community on filter effectiveness. These results are for established filter operations.

	No <sup>1/</sup> Biological Community Filter 3	Control Filter 1	Augmented <sup>2/</sup> Biological Activity Filter 4	Number of Samples
Total Coliform Removal (%)	60.1	97.5	99.9	24
Standard Plate Count Removal (%)	-89	-41	58	23
Turbidity Removal (%)	5	15	52	26

<sup>1/</sup>This filter was chlorinated between test runs.

<sup>2/</sup>This filter had nutrients added continuously.

These results leave little doubt about the important role of the biological population within the sand bed and that the slow sand filter removal mechanism is strongly influenced by biological processes. Also, they show that biological development could be accelerated by nutrient addition. This could be important for start-up of a new system. The cost for this should be nominal. Guidance on how much should be added and for how long could be provided by further research, though development of a practice should not be held up for this reason. Amounts can be determined empirically if done under the guidance of a sanitary engineer or a microbiologist.



Table 30. Summary of results for Giardia cyst experiments for Phase I slow sand filtration, 2/1982 to 1/1983.

TEST IDENTIFICATION										ANALYSIS										RESULTS									
Filter Run No.	Dates of Runs	Hydraulic Loading Rate (m/h)	Temp. (°C)	Age of Schmutzdecke (weeks)	Special Conditions Imposed	Analysis Technique	Average Directional Limit (c/L)		Influent Cyst Concentration (c/L)		Mark-rate of Filter Recovery Efficiency (%)	No. of Effluent Samples (No.)	Effluent Volume Sampled (L)	Cysts in Effluent		Effluent Cyst Concentration		Percent Removal											
							(c/L)	(c/L)	Added	Detected				Corrected	Detected	Based on Cysts Detected	Corrected Limit	Based on Cysts Detected	Corrected Limit	Based on Cysts Detected	Corrected Limit								
48	2/28-3/3	0.04	5	0	C	EP	0.065	420	196.0	46.9	5	65	49	130.9	2.014	2.014	99.520	99.520	>99.999										
54	3/18-3/21	0.04	15	3	M	EP	0.061	500	1137.0	61.2	5	84	13	31.2	0.251	<0.290	99.949	>99.942	>99.999										
60	4/1-6/6	0.04	5	5	M	EP	0.062	500	399.3	79.9	5	81	0	0.000	<0.062	100.000	99.988	>99.988											
66	5/17-5/24	0.04	15	11	M	EP	0.040	50	35.0	71.7	7	376	5	0.7	0.050	<0.076	99.900	>99.848	>99.999										
69	5/25-5/29	0.04	5	12	M	EP	0.037	50	31.3	62.6	5	140	0	0.000	<0.137	100.000	99.772	>99.725											
75	6/6-6/25	0.04	15	0	C	EP	0.036	50	15.9	31.8	11	314	0	0.000	<0.036	100.000	100.000	>99.928											
81	7/4-7/23	0.04	5	0	C	EP	0.104	50	32.2	64.3	10	344	0	0.000	<0.104	100.000	99.901	>99.792											
87	8/1-8/6	0.04	25	4	M	MP	0.093	1000	187.2	18.4	4	111	0	0.000	<0.093	100.000	100.000	>99.941											
90	8/8-8/12	0.04	15	5	M	MP	0.586	1000	221.0	22.1	4	157	0	0.000	<0.586	100.000	100.000	>99.982											
101	10/20-10/25	0.04	15	21	M	MP	0.200	1007	853.0	78.5	5	138	0	0.000	<0.200	100.000	100.000	>99.982											
104	10/26-10/31	0.04	15	12	M	MP	0.331	5075	2705.0	53.3	5	171	0	0.000	<0.331	100.000	100.000	>99.985											
107	11/3-11/7	0.04	15	0	C	MP	0.302	1500	726.0	48.4	4	142	0	0.000	<0.302	100.000	100.000	>99.980											
110	11/12-11/16	0.04	15	0	C	MP	0.151	1953	1556.0	79.7	4	176	0	0.000	<0.151	100.000	100.000	>99.982											
116	12/7-12/11	0.12	15	0	R	MP	0.046	3692	3470.0	94.0	4	497	0	0.000	<0.046	100.000	100.000	>99.989											
118	1/18-1/21	0.40	15	0	F	MP	0.049	2000	1440.0	72.0	5	610	0	0.000	<0.049	100.000	99.150	>99.999											
47	2/28-3/3	0.12	5	0	C	EP	0.030	420	196.0	46.9	5	182	105	280.4	1.541	1.541	99.533	99.533	>99.999										
51	3/18-3/23	0.12	15	3	M	EP	0.023	500	1137.0	61.2	5	221	14	26.1	0.212	<0.212	99.917	>99.917	>99.999										
59	4/1-6/6	0.12	5	5	M	EP	0.033	500	399.3	79.9	5	220	4	1.8	0.015	<0.054	99.907	>99.908	>99.999										
65	5/17-5/24	0.12	15	11	M	EP	0.016	50	35.0	71.7	7	429	4	1.0	0.012	<0.024	99.968	>99.968	>99.999										
68	5/25-5/29	0.12	5	12	M	EP	0.015	50	31.3	62.6	5	345	7	14.0	0.041	<0.046	99.918	>99.918	>99.999										
74	6/6-6/25	0.12	15	0	C	EP	0.014	50	15.9	31.8	11	603	0	0.000	<0.014	100.000	100.000	>99.972											
80	7/4-7/23	0.12	5	0	C	MP	0.043	50	32.2	64.3	10	853	0	0.000	<0.043	100.000	100.000	>99.972											
86	8/1-8/6	0.12	15	4	M	MP	0.308	1000	187.2	18.4	4	277	0	0.000	<0.308	100.000	100.000	>99.960											
89	8/8-8/12	0.12	15	5	M	MP	0.246	1000	221.0	22.1	4	274	0	0.000	<0.246	100.000	100.000	>99.975											
102	10/20-10/25	0.12	15	11	M	MP	0.081	1007	853.0	78.5	5	312	0	0.000	<0.081	100.000	100.000	>99.993											
105	10/26-10/31	0.12	15	12	M	MP	0.091	5075	2705.0	53.3	5	435	0	0.000	<0.091	100.000	100.000	>99.998											
108	11/3-11/7	0.12	15	0	C	MP	0.121	1840	726.0	48.4	4	354	0	0.000	<0.121	100.000	100.000	>99.992											
111	11/12-11/16	0.12	15	0	C	MP	0.059	1953	1556.0	79.7	4	454	0	0.000	<0.059	100.000	100.000	>99.997											
119	1/18-1/21	0.40	15	10	M	MP	0.039	2000	1440.0	72.0	5	770	0	0.000	<0.039	100.000	100.000	>99.999											
49	2/28-3/3	0.40	5	0	C	EP	0.020	420	196.0	46.9	5	270	549	1665.3	5.031	5.031	98.707	98.707	>99.999										
55	3/18-3/21	0.40	15	2	M	EP	0.015	500	1137.0	61.2	5	346	48	11.1	0.321	<0.321	99.936	>99.936	>99.999										
61	4/1-6/6	0.40	5	5	M	EP	0.014	500	399.3	79.9	5	366	26	40.7	0.111	<0.117	99.978	>99.977	>99.999										
67	5/17-5/24	0.40	15	2	M	EP	0.006	50	35.0	71.7	7	1098	7	12.2	0.011	<0.014	99.978	>99.971	>99.999										
70	5/25-5/29	0.40	5	3	M	EP	0.005	50	31.3	62.6	5	762	0	16.0	0.017	<0.019	99.966	>99.963	>99.999										
76	6/6-6/25	0.40	15	0	C	EP	0.005	50	15.9	31.8	11	2238	1	3.9	0.002	<0.006	99.996	>99.988	>99.999										
82	7/4-7/23	0.40	5	0	C	MP	0.013	50	32.2	64.3	10	2671	0	0.000	<0.013	100.000	100.000	>99.974											
88	8/1-8/6	0.40	15	4	M	MP	0.127	1000	187.2	18.4	4	871	220	1195.7	1.373	<1.407	99.853	>99.853	>99.999										
91	8/8-8/12	0.40	15	5	M	MP	0.109	1000	221.0	22.1	4	841	0	0.000	<0.109	100.000	100.000	>99.989											
101	10/20-10/25	0.40	15	11	M	MP	0.024	1007	853.0	78.5	5	1134	0	0.000	<0.024	100.000	100.000	>99.998											
106	10/26-10/31	0.40	15	12	M	MP	0.027	5075	2705.0	53.3	5	1440	0	0.000	<0.027	100.000	100.000	>99.999											
109	11/3-11/7	0.40	15	0	C	MP	0.016	1500	726.0	48.4	4	1199	0	0.000	<0.016	100.000	100.000	>99.998											
112	11/12-11/16	0.40	15	0	C	MP	0.076	1953	1556.0	79.7	4	1020	0	0.000	<0.076	100.000	100.000	>99.999											
117	12/7-12/11	0.12	15	5	M	MP	0.040	3692	3470.0	94.0	4	566	0	0.000	<0.040	100.000	100.000	>99.999											

Table 30. continued.

- 1/ Special Conditions: If none, C-adsorbents scraped just prior to test run, 9-filter bed blocked by draining, leaving dry for two days, stirring sand on top, beating on filter with hammer, and rapidly backfilling, R-resanked filter, 18 inches of sand replaced with new sand, gravel left intact. F-new filter media for entire column, both sand and gravel replaced.
- 2/ The analysis technique is either zinc sulfate flocculation (ZF) or micropipette (MP). These methods are described in Appendix J.
- 3/ Detection limits are explained in Appendix K.
- 4/ The cyst concentration designated as "added" equals the number of cysts in the cyst concentrate, as determined by the stool technique, divided by the number of liters in the feed tank.
- 5/ The cyst concentration designated as "detected" is determined by concentrating a sample from the filter feed tank, with a 142 mm polycarbonate membrane filter having a 5 µm pore size and analyzing for Giardia cysts.
- 6/ The Membrane Recovery Efficiency is calculated as:  $100 \text{ (Detected Cyst Concentration) / (Added Cyst Concentration)}$ .
- 7/ Sampling was by passing effluent stream through 142 mm polycarbonate membrane filter having 5 µm pore size.
- 8/ The corrected number of cysts equals:  $(\text{No. of Cysts Detected}) / (\text{Membrane Recovery Efficiency})$ . If the ZF method of analysis is used, the membrane recovery efficiency is multiplied by 0.8. The 80% factor is used to correlate ZF to MP, i.e. the ZF is only 80% as effective as MP.
- 9/ These values were calculated by:  $(\text{Number of Cysts in Effluent Corrected for Recovery Efficiency}) / (\text{Effluent Volume Sampled})$
- 10/ These values were calculated by:  $1 / (\text{Number of Cysts in Effluent Corrected for Recovery Efficiency} \times (\text{Average Detection Limit}) (\text{Volume Sampled when } 90 \text{ Cysts were Detected})) / (\text{Effluent Volume Sampled})$ .
- 11/ These values were calculated by:  $10011 - (\text{Effluent Cyst Concentration Based on Cysts Detected}) / (\text{Influent Cyst Concentration Added})$
- 12/ These values were calculated by:  $10011 - (\text{Effluent Cyst Concentration Corrected for Detection Limits}) / (\text{Influent Cyst Concentration Added})$
- 13/ The influent cyst concentration added had an error of unknown origin, so this test run was assigned an average value calculated from the first 13 test runs in this table.
- 14/ Test results prior to this date were not used because a cartridge filter was used instead of a membrane filter for sample concentration. This technique could not be calibrated.

NOTE: Complete data for these test runs are given in Appendix A.

Table 31. Summary of results for Giardia cyst experiments for Phase II slow sand filtration, 4/83 to 8/83.

Filter <sup>1/</sup> No.	Date	Flow m <sup>3</sup> /h	Temp (°C)	Special <sup>2/</sup> Conditions Imposed	Detection <sup>3/</sup> Limit (c/L)	Influent Cyst <sup>4/</sup> Concentration Added (c/L)	Recovery <sup>5/</sup> Efficiency (%)	Number of Effluent Samples (No.)	Effluent <sup>6/</sup> Volume Sampled (No.)	Cysts in Effluent		Effluent Cyst Concentration		Percent Removal	
										Cysts Detected (No.)	Corrected <sup>7/</sup> Efficiency (No.)	Based on Cysts <sup>8/</sup> Detected c/L	Corrected for <sup>9/</sup> Detection Limit c/L	Based on Cysts <sup>10/</sup> Detected	Corrected For <sup>11/</sup> Detection Limit (%)
1	5/4-8/4	0.12	10	NONE	0.42	3000	50	3	38	0	0	0	<0.42	100	>99.99
	21/4-22/4	0.12	10	NONE	1.33	1956	50	1	30	0	0	0	<1.33	100	>99.93
	3/5-8/5	0.12	10	NONE	1.18	1845	50	1	34	0	0	0	<1.18	100	>99.94
2	5/4-8/4	0.12	10	1/2	0.43	3000	50	3	95	0	0	0	<0.43	100	>99.99
	21/4-22/4	0.12	10	3/2	1.33	1954	50	1	30	0	0	0	<1.33	100	>99.93
	3/5-8/5	0.12	10	1/2	1.08	1845	50	1	37	0	0	0	<1.08	100	>99.94
3	5/4-8/4	0.12	10	Cl <sub>2</sub>	0.58	3000	50	3	71	0	0	0	<0.58	100	>99.98
	21/4-22/4	0.12	10	Cl <sub>2</sub>	1.74	1956	50	1	35	0	0	0	<1.74	100	>99.91
	3/5-8/5	0.12	10	Cl <sub>2</sub>	1.11	1845	50	1	36	0	0	0	<1.11	100	>99.94
4	5/4-8/4	0.12	10	NUT	0.33	3000	50	3	125	0	0	0	<0.33	100	>99.99
	21/4-22/4	0.12	10	NUT	1.38	1956	50	1	29	0	0	0	<1.38	100	>99.93
	3/5-8/5	0.12	10	NUT	1.05	1845	50	1	38	0	0	0	<1.05	100	>99.94
5	5/4-8/4	0.12	5	LS,LP	0.47	3000	50	3	87	0	0	0	<0.47	100	>99.98
	21/4-22/4	0.12	5	LS,LP	1.48	1956	50	1	26	0	0	0	<1.48	100	>99.92
	3/5-8/5	0.12	5	LS,LP	1.05	1845	50	1	38	0	0	0	<1.05	100	>99.94
6	5/4-8/4	0.12	5	LT	0.34	3000	50	3	122	0	0	0	<0.34	100	>99.98
	21/4-22/4	0.12	5	LT	1.48	1956	50	1	27	0	0	0	<1.48	100	>99.92
	3/5-8/5	0.12	5	LT	1.33	1845	50	1	30	0	0	0	<1.33	100	>99.93
7	21/7-28/7	0.12	10	LS	0.41	3227	50	2	100	0	0	0	<0.41	100	>99.99
	16/8-18/8	0.12	10	LS	0.41	2768	74	2	100	0	0	0	<0.41	100	>99.99
	18/8-17/8	0.17	10	LS	0.20	2188	74	1	112	2820	3124	28.0	<0.41	100	>99.99

<sup>1/</sup>Filter 1 was the control filter; filter 2 had one half sand bed depth; filter 3 was chlorinated between test runs; filter 4 had nutrients added; filter 5 had 0.615 mm sand and was cooled to 5°C; filter 6 was cooled to 5°C; filter 7 had 0.615 mm sand.

<sup>2/</sup>Special conditions are: 1/2 - one half the sand bed depth, Cl<sub>2</sub> = chlorinated between test runs, NUT = nutrient addition, LS = large sand (0.10 - 0.615 mm), LT = low temperature (5°C).

<sup>3/</sup>Detection limits are explained in Appendix K.

<sup>4/</sup>The influent cyst concentration equals the number of cysts in the cyst concentrate, as determined by the Stoll technique, added to the filter feed tank divided by the number of liters in the feed tank.

<sup>5/</sup>The average filter recovery was not calculated for any tests except for Filter 7 tests. The 50 percent efficiency used in approximately equal to the average membrane filter recovery efficiency for all the Phase I testing.

<sup>6/</sup>This is the volume of sample concentrated from the filter effluent with a 142 mm membrane filter with 5 µm pore size.

<sup>7/</sup>The corrected number of cysts equals: (No. of Cysts Detected)/(Membrane Filter Recovery Efficiency).

<sup>8/</sup>These values were calculated by: (No. of Cysts in Effluent) / (Corrected for Recovery) / (Effluent Volume Sampled).

<sup>9/</sup>These values were calculated by: (No. of Cysts in Effluent) / (Corrected for Recovery) / (Detection Limit) / (Effluent Volume Sampled).

<sup>10/</sup>These values were calculated by: 100(1 - (Effluent Cyst Concentration Based on Cyst Detected)/(Influent Cyst Concentration Added)).

<sup>11/</sup>These values were calculated by: 100(1 - (Effluent Cyst Concentration Corrected for Detection Limit)/(Influent Cyst Concentration Added)).

## REMOVALS OF DEPENDENT VARIABLES

This section presents the filter performance in terms of the dependent variable removals, i.e., Giardia cysts, total coliform bacteria, fecal coliform bacteria, standard plate count bacteria, particles, and turbidity. The results are presented for all conditions of operation and summarize the capabilities of the slow sand filter for removal of these variables.

### Giardia Cyst Removal

Table 30 summarizes the Giardia cyst removal results for Phase I testing. Table 31 summarizes the Phase II results. These two tables summarize the Giardia testing program showing test conditions, cyst analysis techniques, and cyst data. The data were abstracted from Appendix C.

The results show that removals of Giardia cysts were uniformly high, exceeding 98 percent under the most stressful condition imposed. Giardia cysts were detected in about half of the effluent sample in Phase I. Once a filter had a "mature" microbiological population, cysts were not detected in the effluent and removals were reported in terms of "detection limit". Table 31, showing Phase II results, indicates only one breakthrough of Giardia cysts. This was attained only after "many" tests in which cyst breakthrough was expected but not attained. Finally, using a sand having a  $d_{10} = 0.615$  mm, a hydraulic loading rate of 0.47 m/hr, and a high influent cyst concentration, breakthrough was attained.

These results show simply that removals of Giardia cysts by slow sand filtration are high even under the most stressed conditions. Removals approached 100 percent showing no functional responses to hydraulic loading rate, temperature, sand size (below 0.278 mm), sand bed depth, schmutzdecke removal, or sand replacement. While filtration through a new sand bed will remove 98 percent of cysts or more, development of the biological population within the sand bed will cause removals to approach 100 percent.

### Total Coliform Removal

Table 32 summarizes the total coliform bacteria removal results for Phase I, Phase II and Phase III testing. It presents an overview of coliform testing, illustrating the experiment themes for each phase and the test conditions for each filter.

Table 32 shows that percent removals of total coliform bacteria for the Phase I filters, i.e. 99.957, 99.675 and 99.017 percent, were higher than for the Phase II and III filters. This is due most likely to the longer operating period of the Phase I filters. The longer period of operation of the Phase I filters which spanned 16 months, provided for more testing when the filters were biologically mature, hence, the higher percent removals. When the state of biological maturity for each filter is considered the results between Phases I and II compare favorably with each other. The removals shown are similar also to those obtained by other researchers, e.g., Poynter and Slade (1977).

Table 32. Total coliform removal by slow sand filtration.

	PHASE I <sup>1/</sup>			PHASE II <sup>2/</sup>						PHASE III <sup>3/</sup>					
	1 <sup>1/</sup>	2 <sup>1/</sup>	3 <sup>1/</sup>	1	2	3	4	5	6	1	2	3	4	5	6
Filter No.															
Sand Size (mm)	0.27	0.27	0.27	0.287	0.287	0.287	0.287	0.615	0.287	0.287	0.287 <sup>2/</sup>	0.128	0.287	0.615	0.287
Sand Depth (m)	97	97	97	48	97	97	97	97	97	97	97	97	97	97	97
Hydraulic loading (m/hr)	0.94	0.12	0.40	0.12	0.12	0.12	0.12	0.12	0.12	0.12	0.12	0.12	0.12	0.12	0.12
Temperature (°C)	15	15	15	17	17	17	17	5	5	17	17	17	17	17	2
Nutrient Addition	None	None	None	None	None	Cl <sub>2</sub>	Yes	None	None	None	None	None	None	None	None
Number of Tests	81	81	81	108	82	43	81	82	82	25	16	25	25	25	25
Geometric Mean Influent (no./100ml)	346	346	346	7668	7102	8286	7134	7102	7102	14389	39284	14389	14389	14389	14386
Geometric Mean Effluent (no./100ml)	1.7	4.8	14.9	246	332	3531	9	1192	914	439	1466	913	192	1042	915
Geometric Mean Removal (%)	99.5	98.6	95.7	96.8	95.3	57.4	99.9	83.2	87.1	96.9	96.3	93.6	98.7	92.8	93.6

NOTE A: This table was constructed from the information contained in Appendix B.

B: Phase I testing: hydraulic loading rates were different

Phase II Filter 1 was the control, Filter 2 had 1/2 the sand bed depth, Filter 3 had no biological population (chlorinated), Filter 4 had nutrients added, Filter 5 had large sand and was operated at 5°C, Filter 6 was operated at 2°C.

Phase III Filter 1 was the control, Filter 2 had a diatomaceous earth surface coating, Filter 3 had small sand, Filter 4 was taken off of nutrients, Filter 5 had large sand, Filter 6 was operated at 2°C.

C: The shading indicates the process variables of interest.

<sup>1/</sup> Calculations were made using only days when data were available for each of the Phase I filters.

<sup>2/</sup> This filter was coated with approximately 3 kg/m<sup>2</sup> of CS45 diatomaceous earth.

Appendix D shows daily removals of total coliform bacteria for all filters used in each of the three phases of experimentation. It also has summaries of removals for each of the filters. Tables D-1 and D-2 compare the Phase I results for Filters 1, 2 and 3. Table D-3 and D-4 present the Phase II results and Tables D-5 and D-6 present the Phase III results. Tables D-2, D-4 and D-6 show the overall percent removals for each filter. These removals are calculated as geometric means of the influent and effluent total coliform analyzes. Two averages are presented in these tables. The first average was calculated with all available data. The second average for Phase I testing was calculated with data from those days when data were available for all three filters. The second average for Phase II and III testing was calculated with data from days when the filter was biologically mature.

The results shown in Table 31 demonstrates that coliform removal for a biologically established slow sand filter exceeds 95 percent for most operating conditions. It was shown also that for various conditions of design and operation the removal can vary from 80 percent to 99.9 percent. The conditions which tend to decrease removal in an established filter are: 1) cold temperature; 2) increased hydraulic loading rate; 3) large sand; 4) decreased sand bed depth; 5) decreased nutrient availability; 6) decreased influent contaminant concentration, 7) removal of the schmutzdecke, and 9) replacing the sand. The biological maturity of the filter has the greatest influence on coliform removals. As the biological community develops in the schmutzdecke and sand bed, removal improves from about 60 percent at start-up to greater than 99 percent for a biologically mature filter.

Coliform bacteria proved to be highly appropriate as indicators of filter performance for three reasons. First, they will not be propagated in the filter bed. Second, they are easy to analyze. Third, they are used within the water industry as a standard indicator. The premise has been that if coliforms are removed during treatment then pathogens will be removed also. Other researchers have shown that virus and bacterial pathogen removal by slow sand filtration is as good or better than coliform removal, e.g., den Blanken (1982), McCarthy (1975), Hazen (1913).

#### Fecal Coliform Removal

Table 33 summarizes results of fecal coliform testing, which was done only for four months during Phase I testing. Average percent removals are shown, along with corresponding geometric means of influent and effluent concentrations. The fecal coliform removals were about the same as total coliform removals. Percent removals were 99.7, 99.5 and 99.1 for Filters 1, 2 and 3, respectively. All data related to fecal coliform testing are in Appendix E.

Table 34. Standard plate count bacteria removal by slow sand filtration.

Filter No.	PHASE I			PHASE II						PHASE III					
	1 <sup>1/</sup>	2 <sup>1/</sup>	3 <sup>1/</sup>	1	2	3	4	5	6	1	2	3	4	5	6
Sand Size (mm)	0.27	0.27	0.27	0.287	0.287	0.287	0.287	0.615	0.287	0.287	0.287 <sup>2/</sup>	0.128	0.287	0.615	0.287
Sand Depth (m)	97	97	97	97	49	97	97	97	97	97	97	97	97	97	97
Hydraulic Loading (m/hr)	0.94	0.12	0.40	0.12	0.12	0.12	0.12	0.12	0.12	0.12	0.12	0.12	0.12	0.12	0.12
Temperature (°C)	15	15	15	17	17	17	17	5	5	17	17	17	17	17	2
Nutrient Addition	None	None	None	None	None	Cl <sub>2</sub>	Yes	None	None	None	None	None	None	None	None
Number of Tests <sup>3/</sup>	117	117	117	80	80	42	78	80	80	43	16	39	43	43	43
Geometric Mean Influent (no./mL)	2869	2869	2869	624	624	595	628	624	624	904	630	1524	904	904	904
Geometric Mean Effluent (no./mL)	538	489	686	825	603	1075	352	249	223	150	141	495	170	279	165
Geometric Mean Removal (%)	81	83	76	-32	3	-80	44	60	64	83	77	68	81	69	82

NOTE A: This table was constructed from the information contained in Appendix F.

B: Phase I testing: hydraulic loading rates were different.

Phase II testing: Filter 1 was the control, Filter 2 had 1/2 the sand bed depth, Filter 3 had no biological population, Filter 4 had nutrients added, Filter 5 had large sand and was operated at 5°C, Filter 6 was operated at 5°C.

Phase III testing: Filter 1 was the control, Filter 2 had a diatomaceous earth surface coating, Filter 3 had small sand, Filter 4 was taken off of nutrients, Filter 5 had large sand, Filter 6 was operated at 2°C.

C: The shading indicates the process variables of interest.

D: Removals were calculated with 24 hour separation between influent and effluent values.

<sup>1/</sup> Calculations were made using only days when data were available for each of the Phase I filters.

<sup>2/</sup> This filter was coated with approximately 3 kg/m<sup>2</sup> of C545 diatomaceous earth.

<sup>3/</sup> Nine of the Phase III tests were spiked with greater than 5x10<sup>5</sup> bacteria.

Table 33. Fecal coliform removal by slow sand filtration, Phase I results.

Filter Number	Hydraulic Loading Rate (m/h)	Number of Tests (No.)	Geometric Mean Influent Concentrations (Coliforms/100 mL)	Geometric Mean Effluent Concentrations (Coliforms/100 mL)	Average Fecal Coliform Removal (%)
1	0.04	27	444	1.44	99.7
2	0.12	27	444	2.08	99.5
3	0.40	27	444	3.95	99.1

Note: Complete fecal coliform data are given in Appendix E.

#### Standard Plate Count Removal

Table 34 summarizes the standard plate count bacteria analyzes for Phase I, Phase II and Phase III testing. The results are average removals for all conditions of operation, i.e., start-up through mature operation. They were calculated from data in Appendix F, which contains the daily removals. Tables F-2, F-4 and F-6 summarize the percent removals for each filter. Two averages are presented in these tables. The first average was calculated with all available data and the second was calculated with data from those days when analyzes were available for all three filters.

The use of standard plate count bacteria as an indicator of performance presents a problem when interpreting results. Since there is an active biological community within a slow sand filter it is expected that bacteria will be sloughed from the filter. The base level effluent concentration of standard plate count bacteria observed for Phase II and III testing was 100 to 200 colonies per milliliter. The concentration of standard plate count bacteria present in the raw water from Horsetooth Reservoir water was about the same. Thus percent removals were usually small or negative during day to day operation without spiking. Because of this, standard plate count bacteria was not considered a suitable indicator for evaluating filter effectiveness. When the filter influent was spiked, however, it was useful. As an example, the influent to Filter 1 was spiked with approximately  $5 \times 10^5$  standard plate count bacteria from November 20 to November 29 during Phase III tests. Results showed 99 percent removal. Also, during the Phase I testing the influent concentration of standard plate count bacteria was higher due to sewage addition and results showed 76 to 83 percent removal.

The phenomenon of bacterial production and sloughing was studied further by increasing and decreasing influent standard plate count bacteria above and below ambient conditions. The procedures used are described in a previous paragraph. The influent concentration was varied between  $<10^4$  colonies per milliliter to  $>10^5$  colonies per milliliter. Figure 60 shows the results of these tests for Filter 1 during Phase II and III testing. The curve representing the trend in the data indicates that effluent standard plate



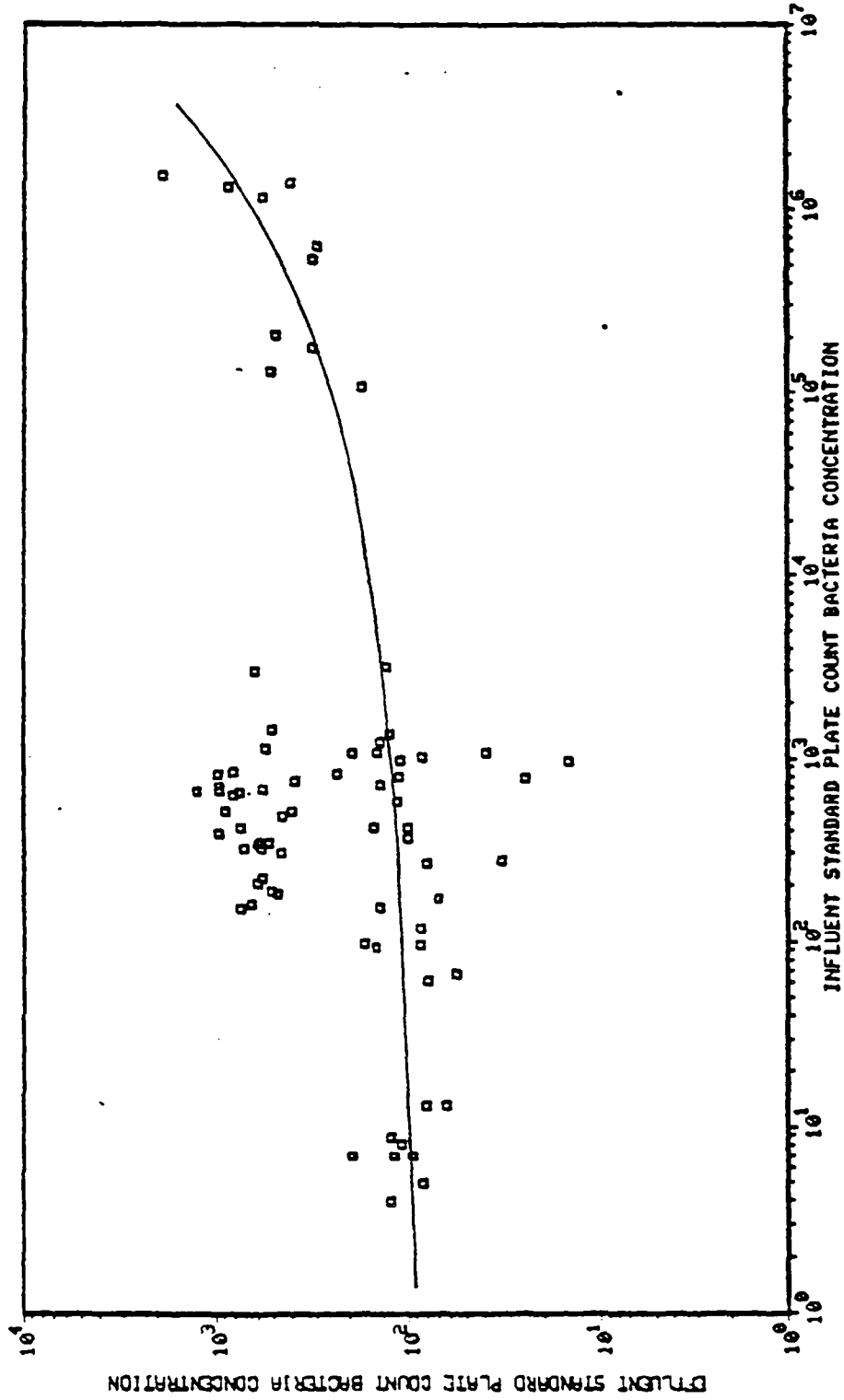

Figure 60. Influent versus effluent standard plate count bacteria concentrations for slow sand filtration. Values obtained from a mature filter operating with an effective sand size of 0.287 mm, at a hydraulic loading rate of 0.12 m/h and at a temperature of 17°C, Filter 1, Phase II and III testing.

count bacteria concentration is independent of the influent concentration over a range of 1 to approximately 1000 colonies/ml. Also, the data indicate that very large influent concentrations are needed to cause an increase in effluent concentrations.

Figure 61 is a representation of the trend indicated in Figure 60. The influent concentration from point "a" to point "b" represents the range in which the effluent standard plate count bacteria concentration is at the "base level". The magnitude of the base level concentration is unique for a given set of operating and ambient water conditions, (e.g. nutrient concentration, temperature). Beyond point b the influent bacteria concentration begins to overwhelm the filter's removal capacity. From this point on the bacteria in the effluent will be comprised of both generated bacteria and those influent bacteria which pass through the filter. Figure 61 illustrates the bacteria "passed through" the filter, i.e., the level leaving above base level, and the bacteria "removed", which are those entering less the base level.

Figure 62 was hypothesized and constructed by Allen Hazen in 1913, The Filtration of Public Water Supplies. Although Hazen did not have the data to support his hypothesis it is apparent that he believed a removal of influent bacteria was occurring with a corresponding generation and discharge of bacteria from the filter. This concept explains the baseline or lower concentration of bacteria discharge from a slow sand filter for given design, operating and ambient conditions. The test described above confirms this hypothesis.

#### Turbidity Removal

Table 35 summarizes the turbidity removal results for all of the slow sand filtration testing. The table shows averages of influent and effluent turbidities obtained during all test conditions for each phase of testing and for each filter.

Table 35 shows that the Phase I testing demonstrated average turbidity removals ranging from 27 to 39 percent while average removals for the Phase II and Phase III ranged from 7 to 18 percent. The differences occurred because the Phase I results included many more values obtained during operations with biologically mature filters. A high proportion of Phase II and Phase III results on the other hand, were obtained during start-up and after schmutzdecke removal.

Appendix G contains all of the turbidity information collected during testing. It can be seen in Table G-1, Appendix G that "negative removals" appear for some daily turbidity percent removals. These removals are calculated by using the influent and effluent values from the same day. Therefore, if a rapid decline in influent turbidity takes place, a negative removal will result, due to an insufficient time for it to be reflected in the effluent; this was not a common occurrence. A negative removal can also result if biological sloughing is occurring during the effluent sample collection. In addition, negative removals may occur during the initial

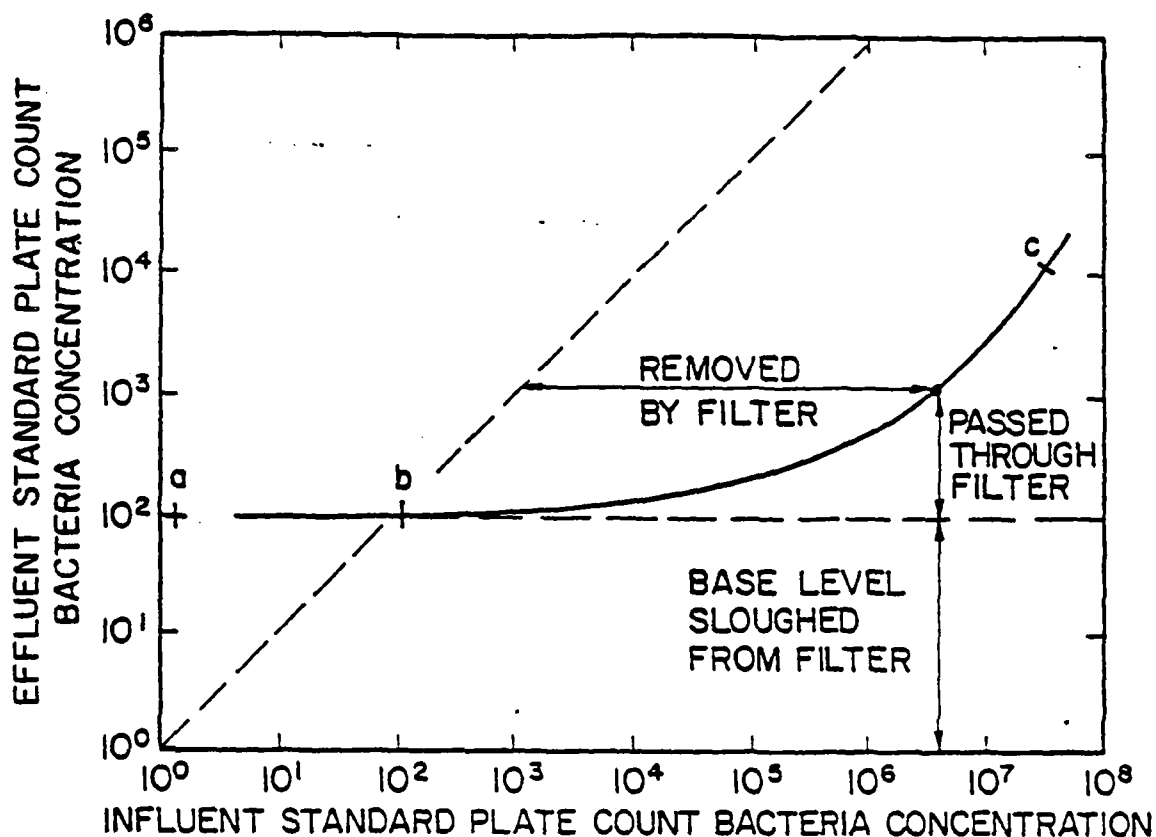

Figure 61. Generalization of the influence of influent bacteria concentrations on effluent bacteria concentrations for slow sand filtration.

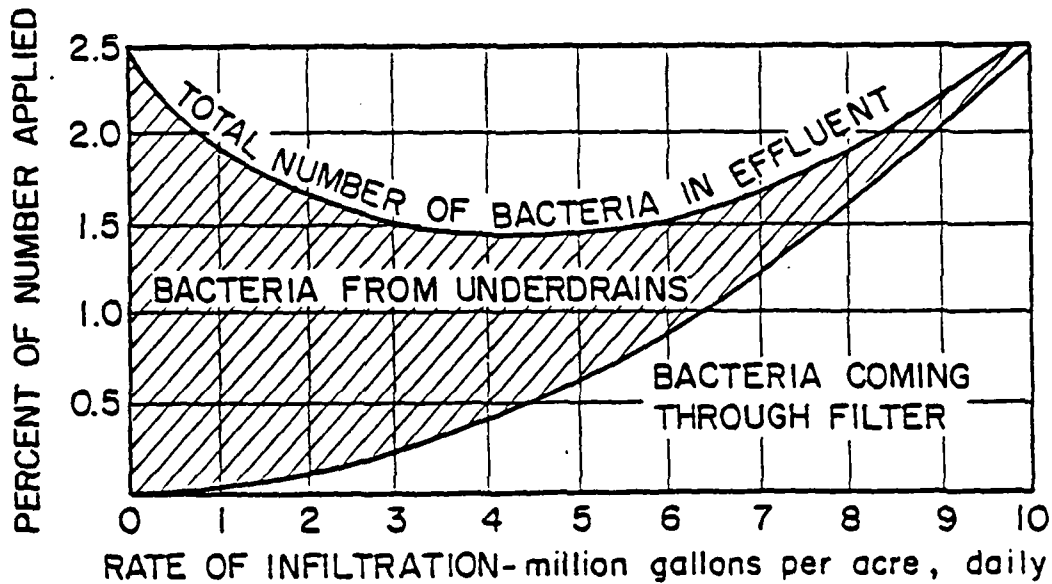

Figure 62. Effect of hydraulic loading on the composition of the effluent bacteria concentration (from Hazen, 1913).

Table 35. Turbidity removal by slow sand filtration.

Filter No.	PHASE I			PHASE II						PHASE III					
	1 <sup>1/</sup>	2 <sup>1/</sup>	3 <sup>1/</sup>	1	2	3	4	5	6	1	2	3	4	5	6
Sand Size (mm)	0.27	0.27	0.27	0.278	0.278	0.278	0.278	0.515	0.278	0.278	0.278 <sup>2/</sup>	0.138	0.278	0.615	0.278
Sand Depth (m)	97	97	97	97	48	97	97	97	97	97	97	97	97	97	97
Hydraulic Loading (m/hr)	0.04	0.12	0.40	0.12	0.12	0.12	0.12	0.12	0.12	0.12	0.12	0.12	0.12	0.12	0.12
Temperature (°C)	15	15	15	17	17	17	17	17	17	17	17	17	17	17	17
Nutrient Addition	None	None	None	None	None	Cl <sub>2</sub>	Fe <sup>3+</sup>	None	None	None	None	None	None	None	None
Number of Test	297	297	297	87	87	87	87	87	87	87	17	43	44	44	44
Average Influent (NTU)	6.01	6.01	6.01	7.2	7.2	7.2	7.2	7.2	7.2	7.1	7.7	7.1	7.1	7.1	7.1
Average Effluent (NTU)	3.66	4.08	4.37	6.2	6.3	6.7	4.2	6.7	6.7	6.2	6.3	8.2	6.6	6.2	6.0
Average Removal (%)	39	32	27	14	12	7	42	7	7	13	18	-15	7	13	15

NOTE A: This table was constructed from the information contained in Appendix 6.

B: Phase I testing: Hydraulic loading rate was different.

Phase II testing: Filter 1 was the control, Filter 2 had 1/2 the sand bed depth, Filter 3 had no biological population, Filter 4 had nutrients added, Filter 5 had large sand and was operated at 5°C, Filter 6 was operated at 5°C.

Phase III testing: Filter 1 was the control, Filter 2 had a diatomaceous earth surface coating, Filter 3 had small sand, Filter 4 was taken off of nutrients, Filter 5 had large sand, Filter 6 was operated at 2°C.

C: The shading indicates the process variables of interest.

<sup>1/</sup>Calculations were made using only days when data were available for each of the Phase I filters.

<sup>2/</sup>This filter was coated with approximately 3 kg/m<sup>2</sup> of CS45 diatomaceous earth.

start-up of a filter. This can be caused by fines being washed out of the sand bed and by excessive bacteria sloughing.

The process variables which were shown to affect turbidity removal were hydraulic loading rate and biological activity. As the hydraulic loading rate decreased turbidity removal increased. This was shown in Figure 38. As the biological activity increased turbidity removal also increased. This was shown by the data in Table 35, comparing Filter 1, the control, and Filters 3 and 4, the chlorinated and nutrients added filters, respectively, in which removals are 14, 7, and 42, respectively.

Turbidity removal, for those particles too small to be strained, was shown to be influenced by the biological maturity of the filter. This can be seen in the start-up data presented in Figure 55 for the control filter and in Figure 56 for the nutrients added filter. Turbidity removal was shown to increase with increasing time except for the chlorinated filter where removal never improved, i.e. no biological assistance.

Turbidity removal, on the whole, was not high. Turbidity removal during all three phases of testing was insufficient to comply with a 1 NTU standard. This was not expected and is not usual for slow sand filtration, e.g. Huisman (1974), Cleasby (1983), Fox, (1983). The low removals were due to the small particles comprising the turbidity in Horsetooth reservoir water which passed through the slow sand filters.

#### Turbidity Characterization—

Turbidity removals during this experimentation were much lower than results reported by others. Normally, effluent turbidity levels can be expected to be less than 1 NTU after slow sand filtration. The higher effluent turbidities experienced in this work can be attributed to the small particles comprising the turbidity in Horsetooth Reservoir water.

The sizes of the particles comprising the turbidity were determined by running membrane filter tests on Horsetooth water. Figure 63 is a plot of turbidity removal versus membrane pore size. As shown the turbidity is not removed to below 1 NTU until a membrane with a pore size of less than 0.45  $\mu\text{m}$  is used. Even a 0.22  $\mu\text{m}$  filter allows 0.49 NTU to pass from an influent of 5.2 NTU.

The values in Table 36 provide a means to gage the relative size of the particles which comprise Horsetooth turbidity to particles in "natural waters". Horsetooth particles would be classified as fine turbidity or colloids.

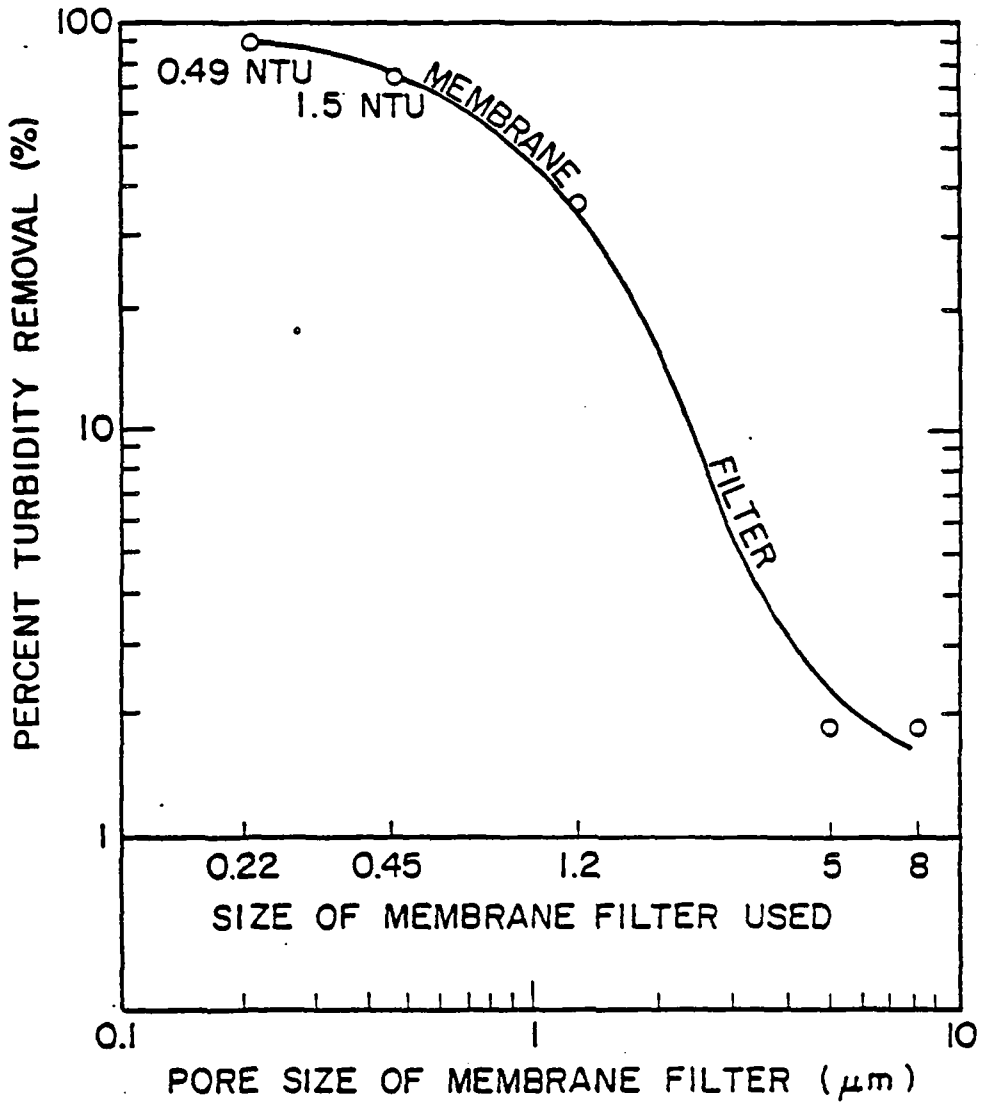

Figure 63. Turbidity removal, from Horsetooth Reservoir water, by membrane filters of different sizes.

Table 36. Typical size of particles in natural water (Beard, 1977).

Source	Diameter of Particle $\mu\text{m}$
Coarse turbidity	1-1000
Algae	3-1000
Silt	10
Bacteria	0.3-10
Fine turbidity	0.1-1
Colloids	0.001-1

A mineral analysis of a turbidity sample from Horsetooth Reservoir water was done by Dr. E. Robert Baumann at Iowa State University using a sample residual from a 0.22  $\mu\text{m}$  membrane filter, through which water from Horsetooth Reservoir was filtered. X-ray diffraction and scanning electron microscopy were used as the analytical methods. His results are included in Appendix L. The particles were identified as kaolinite, illite and montmorillonite in sizes ranging from 6  $\mu\text{m}$  to "lots of smaller (much) particles."

Once the size distribution and mineral nature of the turbidity particles were determined, attention was directed toward learning why the turbidity removal efficiencies were low (as compared with others reported in the literature, e.g. Cleasby, 1983). One explanation could be that none of the turbidity particles were large enough to be retained on the top of the sand bed which could aid in the formation of a schmutzdecke. Another explanation was that the low nutrient levels (<5 mg/L COD) in the Horsetooth water may not be enough to permit adequate development of biological activity within the sand bed so that the filters would function properly. Two tests were conducted to determine if either of these factors might contribute to poor turbidity removal.

First, diatomaceous earth, Maryville C-545 having a  $d_{10} = 0.013$  mm, was deposited at the rate of 3 kg/m<sup>2</sup> on the top of a biologically mature slow sand filter. This was Filter 2, used in Phase III testing. The schmutzdecke was given 40 days to develop on the diatomaceous earth before testing. At the end of this period, turbidity removal was only 9 percent for Filter 2 while the control filter removed 8 percent, see Table 18. These results demonstrated that adding a layer of fine material to improve retention of biological matter for schmutzdecke development did not affect turbidity removal.

The biological activity and amount of biomass was increased in Filter 4, Phase II, by adding sterile synthetic sewage nutrients at a rate sufficient to reduce the dissolved oxygen by 4 to 5 mg/L as contrasted with 1 mg/L in the other filters. Turbidity removal was 42 percent, versus 14 percent for the control filter, as shown in Figure 35. The 4 to 5 ppm dissolved oxygen decrease is greater than most slow sand filter installations experience; consequently, the biological activity can be assumed to be as high as or higher than most slow sand filters producing 1 NTU water. This test showed that enhanced biological activity within the sand bed definitely contributed to improve removal of turbidity, which is shown by comparing percent removals

of turbidity in Figures 55 and 56 for the control and nutrients added filters respectively. Table 35 shows the same comparisons of average percent removals of turbidity. Percent removals of turbidity are sharply improved by adding nutrients to enhance biological activity. Further, Table 35 shows that when Filter 4 was taken off nutrients, in Phase III, the percent removals of turbidity declined to only 7, vis a vis 42 with nutrients. Figure 57, and Table 35 also, show turbidity removals for the chlorinated filter which is presumably devoid of biological activity. Turbidity removals are very low. These results corroborate the role of biological activity within the sand bed in turbidity removal. As discussed previously, it seems likely that the turbidity particles may impinge on the biological film on the sand grains or are coagulated by natural polymers from the microorganisms (see Pavoni et al., 1972).

It was pointed out that there may be a turbidity exchange rather than the turbidity passing through the filter. The above described tests showed that this was not likely.

First, if an exchange of turbidity is occurring it is reasonable to assume that the effluent turbidity is due to sloughing of cellular materials which are products of the biological process. To reiterate, filters were operated at: 1) available nutrient levels (Control Filter 1, Phase II and Phase III), 2) when biologically inactive (Chlorinated Filter 3, Phase II), and 3) with increased biological activity (Nutrient Addition Filter 4, Phase II). The average turbidity removals from these filters, from Table 35, were 14, 7, and 42 percent, respectively. If a turbidity exchange occurred one would expect higher effluent turbidities as the biological activity increased, which was clearly not the case.

Second, the amount of biological material necessary to create a turbidity of 6 NTU, the nominal turbidity level of the raw water from Horsetooth Reservoir, would most probably have to have standard plate count levels far in excess of those detected in the filter effluents. The addition of  $10^6$  standard plate count bacteria per milliliter to the influent of the filters raised the turbidity from 6.1 to 6.7 NTU. This is only a 0.6 NTU rise for  $10^6$  bacteria per milliliter.

Finally, a chlorine demand and disinfection test was performed on the slow sand effluent. The results of these tests, Appendix M, indicate that there is very little difference between the chlorine demand of the slow sand filter effluent and that of the water being produced by the City of Fort Collins. The city normally achieves turbidity levels below 0.1 NTU. This test demonstrates that the turbidity particles being passed by the filter do not create a chlorine demand and are probably not organic matter being produced by the filter.

In summary, the particles which comprise the majority of the turbidity in Horsetooth reservoir water can be characterized as very small, i.e below  $0.5 \mu\text{m}$ , composed of clay, and capable of passing a slow sand filter. The particles comprising this turbidity are not likely to be primarily cellular



The start-up and final operating periods of the Phase I testing shows some variations in flow rate. The first variations were the result of the pilot plant start-up and "debugging." During this period different pumps and flow settings were tried. The latter fluctuations were deliberately produced to test extremes in operating conditions under identical flow rates. No Giardia testing was performed during variations of flow from the designated values.

### Temperature

The temperature histories for the slow sand filters are given also in Figures I-1 through I-9 in Appendix I. The Phase I filter temperatures were allowed to fluctuate with ambient conditions, except during Giardia testing. The ambient temperature ranged between 10°C and 20°C. Giardia testing was kept at 5°C or 15°C. It was determined in preliminary tests that Giardia cysts are not stable for very long at temperatures above 15°C; consequently this was the upper temperature limit used during Giardia testing. This is an area where further research is needed since the information was needed for our experimental work and it would be useful in practice to assess the viability of the cysts in warm waters.

The Phase II and III testing on Filters 1, 2, 3 and 4 was performed at approximately 17°C for all but the Giardia tests; again the temperature was lowered to 10°-15°C for these tests, which was done only to insure cyst viability. Filters 5 and 6 were operated continuously at 5°C for the second phase and then at 17°C and 2°C, respectively, for the third phase of testing, as indicated in Table 24.

### Headloss

The headloss for the entire operating period of each filter is presented in Figures I-1 through I-9 in Appendix I. Headloss was monitored to follow the progress of schmutzdecke development and also the increase in hydraulic resistance within the filter.

Sharp decreases in headloss were caused by removing the schmutzdecke. Figure C-3 shows, for example, that on days 70, 248 and 435 the headloss was greater than 150 cm which was enough to warrant removal of the schmutzdecke. The headloss dropped to 5 cm after the schmutzdecke removal on day 70 and to about 20 cm after the schmutzdecke removal on day 435. This increase in headloss was probably due to silting, which is caused by the gradual accumulation of inorganic and organic particles within the sand column.

Sharp increases in differential pressure, as seen in Figure C-3, were generally concurrent with Giardia test runs. The Giardia cyst suspension, consisting of liquefied dog feces, increased the level of suspended solids in the influent water especially in the size range which tend to form a deposit on the surface of the filter. Consequently, a rapid rise in headloss was experienced during Giardia testing.

material, as suggested by one of the peer reviewers of the Phase I results of this research.

#### Disinfection—

Because effluent turbidity levels from the slow sand filters did not reach the 1 NTU standard, it was considered necessary to perform preliminary disinfection testing. Appendix M contains the results of two test runs which were conducted to evaluate the effect of the turbidity from Horsetooth reservoir on chlorine disinfection. The results indicated that there was not a major difference in chlorine demand nor disinfection effectiveness between the effluents from the slow sand filters, from a diatomaceous filter, or from the rapid sand filters at Fort Collins Water Treatment Plant No. 2, which removes turbidity to 0.1 NTU. These results of tests indicate that the turbidity in the Horsetooth Reservoir water does not interfere with disinfection.

#### Particle Removal

Table H-1, Appendix H, gives the particle counting history for the three slow sand filters for the period from February to June, 1982. It includes daily particle removal percentages for each filter. Table H-2, Appendix H, gives average particle removal percentages. The average removals for hydraulic loading rates of 0.04, 0.12 and 0.40 m/hr are 96.81, 98.50, and 98.02 percent for the 6.35 to 12.7  $\mu$ m size range, respectively. No correlation was found between particle removal and any variable tested.

Because particles such as rotifers and bacteria are continually emitted by the filter during normal operations, it is impossible to differentiate between particles passing through the filter and particles that are sloughed from within the filter. Dr. Hibler observed these organisms repeatedly during microscopic examinations of the filter effluents. Since the general level of removal had been established, i.e. 96 to 98 percent for 6.35 to 12.7  $\mu$ m particles, it was felt further testing was not necessary.

#### MONITORING OF FILTER OPERATIONS

Hydraulic loading, temperature and headloss were monitored for each filter during the three phases of testing. These data are presented in graphical form in Appendix I. The following sections review the behavior exhibited.

#### Hydraulic Loading

The hydraulic loading rate history for the entire operating period of each filter is given in Figures I-1 through I-9 in Appendix I. The hydraulic loading rate for the three Phase I filters was set at 0.04 m/hr, 0.12 m/hr and 0.40 m/hr for Filters 1, 2 and 3, respectively. The rates of 0.04 m/hr, 0.12 m/hr and 0.40 m/hr are equivalent to 1 mgd/acre, 3 mgd/acre and 10 mgd/acre, respectively. The hydraulic loading rate for each of the six Phase II and III filters was set at 0.12 m/hr.

## MECHANISM

This research has demonstrated that removals of bacteria and *Giardia* cysts are influenced predominantly by biological processes. The biological influence was illustrated by the Phase II testing with: 1) Filter 3 which was chlorinated between test runs to prevent biological growth, 2) Filter 1 which was the control, and 3) Filter 4 which had nutrients added to increase the biological activity. The results of these tests, presented in Tables 28, 29, 32, and 35 demonstrate unequivocally the improvement in removals of bacteria and turbidity as the level of biological activity increased. As shown in Table 29 percent coliform removal was 60.1 for the chlorinated filter, 97.5 for the control filter, and 99.9 for the nutrient fed filter. Similarly turbidity removals were 5, 15, and 52 percent. Note that Table 29 summarizes data after filter operations were "established," while Tables 32 and 35 are for all data.

The filtration removal processes most often hypothesized include straining, sedimentation, and adsorption. These processes must occur to some extent in a sand bed without a biological population. But, as seen by the data in Table 29, the effect of increasing the biological activity is pronounced. The micro-organisms exist attached to the surface of the sand grains. The build-up of the biological film will certainly enhance all of the mechanisms mentioned. It seems reasonable to hypothesize, however, that the biofilm provides a surface capable of adsorbing particles that are transported to it, and that this is more important by far than straining or sedimentation. Once attached to this surface biofilm on the sand grains, those particles that are organic are subject to being metabolized by the biological community comprising the biofilm. This mechanism explains the data observed. Some of the clays comprising the turbidity will adhere to the biological matter comprising the schmutzdecke and also the biofilm on the sand grains. As discussed earlier, the latter was found to be most important in turbidity removal. The clays that penetrate into the sand bed deeper and stick to the sand grain biofilm can clog the bed eventually.

The important role suggested for the internal biopopulation within the sand bed was supported also by the Phase I testing which measured coliform and *Giardia* cyst removals at different levels of biological maturity within the filter. These tests were performed with new sand and new gravel support (filter start-up), new sand with mature gravel support, mature sand with schmutzdecke removed, and a mature biological population. The results for these tests are summarized in Figure 59 as a series of bar graphs. The graphs show that filter efficiency is directly related to the maturity of the biological population within the filter, i.e., the filter with new sand and gravel support had the poorest removal while the biologically mature filter had the best removal.

Physical removal at the top of the sand bed without the aid of any "sticky" biological substances, was discounted as a major removal mechanism based on the results of Phase III testing with a diatomaceous earth coated filter; results of this test are contained in Table 42. If physical removal at the sand bed surface was a predominant mechanism, then the efficiency of

this filter should have been far superior to the control filter, which it was not.

The increase in removal of bacteria and of turbidity-causing particulate matter such as clay in these results could be explained by the production of exocellular polymers. In their chapter entitled, "Theory of Biological Filtration," Huisman and Wood (1974) discuss attachment mechanisms that could hold particles in the sand bed after they are removed from the raw water. They mention electrostatic attraction and Von der Waals forces as causing the adhesion. Concerning adhesion, they state that a "sticky gelatinous film" forms on the surfaces of the sand grains and the schmutzdecke. They give no detailed explanation for this. The explanation for the sticky film could be caused by the production of exocellular or extracellular polymers by bacteria residing in the slow sand filter bed. Metcalf and Eddy Inc. (1979) state that polymers produced by microorganisms promote formation of floc particles in the activated sludge process. Further, Pavoni et al. (1972) showed that extracellular polymers produced by activated-sludge bacteria could flocculate Kaolin suspensions. These polymers could be produced by bacteria within the schmutzdecke and within the sand bed of a slow sand filter. Some of the polymer material may remain within the biofilms attached to the sand grains and schmutzdecke, or in the vicinity of these biofilms. It seems quite plausible that these polymers could enhance chances for attachment of clays and bacteria when these particles impinge on the biofilms of the sand grains and schmutzdecke material. Also, trace amounts of extracellular polymer could be released into the water flowing through the filter and might aid in destabilizing clays and bacteria.

The improved turbidity and coliform removal results obtained in the biologically enhanced filter show that the biopopulation of a slow sand filter plays a very important role in the water quality improvement that occurs during slow sand filtration. The extracellular polymers, shown to be produced by activated sludge bacteria process and cause flocculation, could very well have a similar role in promoting adsorption of particles on the biofilms in slow sand filtration, or in destabilizing particles for coagulation and then attachment.

If the mechanism is attachment within the sand bed (with or without metabolism), a mathematical description of removal may fit an equation for contaminant removals by trickling filters, given by Eckenfelder (1966):

$$\frac{L}{L^0} = e^{-kAd/v}$$

Where: L is the effluent contaminant concentration, L<sub>0</sub> is the influent contaminant concentration, k is the mass transfer coefficient (reaction rate constant), A is the surface area of biological slime, d is the depth of filter, and v is the hydraulic loading rate.

This equation predicts that percent removal will increase as the sand surface area, A, increases, i.e., smaller effective sand size, as the depth, d, increases, temperature increases (which increases k) and, as the hydraulic loading rate, v, decreases. All of these effects, as indicated by the equation, are in the directions observed experimentally in this research.

#### Turbidity Removal—

Wide spread experience with slow sand filtration, such as reported by Huisman and Wood (1974) has demonstrated that the slow sand filtration process is efficient in removal of turbidity. Also, Cleasby (1983) operated a pilot filter for 123 days using lake water as a source in which turbidity levels were reduced from 10 NTU to less than 1 NTU in the filtered water.

According to Huisman and Wood (1974) most of the turbidity removal occurs at the surface of the sand bed. Further, Cleasby (1983) has reported that turbidity removal for his situation reached the 1 NTU level within three days of start-up.

The surface of the sand bed is, of course, different than the underlying sand. Any material susceptible to straining by the pores of the sand bed is likely to be removed as it enters the bed rather than within it. This accumulation of material on the surface, called the schmutzdecke, will reinforce itself. As the mat builds, straining of finer particles can occur. The hydraulic gradient across the schmutzdecke will increase at a higher rate than within the sand bed. The schmutzdecke can be any combination of mineral and biological material. The mechanism of removal could be straining or adsorption or both.

In these experiments water from Horsetooth Reservoir was used, having turbidity comprised of fine particles, as noted. Despite the development of a schmutzdecke, as evidenced by headloss increase, turbidity removal was not affected by its buildup, nor by its removal. Turbidity removal was enhanced, however, by increased biological activity within the sand bed. For example, the turbidity removal was about 40 percent for Filter 4 having nutrients added, vis a vis 12 percent for Filter 1, the control filter. Thus in this research the schmutzdecke had a role less important than is generally attributed to it in the literature, e.g., Huisman and Wood (1974).

The mechanism operative in turbidity removal will depend upon the situation at hand. For certain kinds of turbidity, its removal will occur at the surface of the filter, while for the kind present in Horsetooth Reservoir water, removal occurs within the filter and will be enhanced by an increase in biological population.

## REFERENCES

- Alagarsamy, S. R. and M. Gandhirajan. Package and water treatment plants for rural and isolated communities. Journal of Indian Water Works Association (India), 13:1, 73-80, 1981.
- Baker, M. N. The Quest for Pure Water. The American Water Works Ass. New York, 1948.
- Beard, J. D., and T. S. Tanuka. A Comparison of Particle Counting and Nephelometry. Journal of the American Water Works Association, 69(10):533-538, 1977.
- Benarde, M. A. Schistosome cercariae removal by sand filtration. Journal of American Water Works Association, 63:7, 449-453, July, 1971.
- Bergling, S. Jonkoping's water supply. Vattenbyggnadsbyran Ltd., Stockholm, Sweden, Water and Environment Engineering Dept. Aqua, No. 4, 3-5, 1981.
- Blair, J. R. Giardia lamblia Sampling in the Resort Areas of Vail and Aspen - Winter 1980. Unpublished Report, Colo. Dept. of Health-Water Quality Control Div., June, 1980.
- Blair, J. R. Giardia lamblia Contamination at Estes Park, Colorado. Unpublished Report, Colo. Dept. of Health-Water Quality Control Div., Dec., 1979.
- Burman, N. T. "Slow sand filtration." H<sub>2</sub>O, 11:16, 348-351, 1978.
- Cleasby, J. L. Slow sand filtration and direct in-line filtration of a surface water. Pages presented at 103rd Annual AWWA Conference, Las Vegas, NV, June 5, 1983.
- Davies, R. B., Fukutai, K., and Hibler, C. P. Cross Transmission of Giardia. EPA Report No. PB83-117 747, Cincinnati, Ohio, 1983.
- den Blanken, J. G. Microbial activity in activated carbon filters. Journal of the Environmental Engineering Division, Proceedings of the American Society of Civil Engineers, 108:EE2, 405-424, 1982.
- Dobell, C. Antony van Leeuwenhoek and His Little Animals. Harcourt Brace and Co., New York, 224-225, 1932.

- Flickinger, J. and J. Standridge. Identification of fibrous material in two public water supplies. *Environmental Science and Technology*, 10:10, 1028-1032, 1976.
- Folpmers, T. On the disappearance of *Esch. coli* and fecal streptococci (Enterococci) as a result of slow sand filtration. *Leeuwenhoek (Dutch)* 7:104; *Zentr. Ges. Hyg. (Ger.)* 50:580, 1943.
- Fox, G. T. and T. D. Lekkas. Slow sand filters. *Water Services*, 82:984, 113-114, 1978.
- Fox, K. R.; R. J. Miltner; G. S. Logsdon; D. L. Dicks and L. R. Drolet. Pilot plant exploration of slow rate filtration. Presented at AWWA Annual Conference Seminar, Las Vegas, NV, June 5, 1983.
- Hazen, A. The Filtration of Public Water-Supplies. John Wiley & Sons, New York, 3rd ed., 1913.
- Hewlett, E. L., Andrews, J. S., Ruffier, J., and Schaefer, F. W. III, Experimental Infection of Mongrel Dogs with Giardia Lamblia Cysts and Cultured Trophozoites, Journal of Infectious Diseases, 145(1):89-93, 1982.
- Huisman, L. Developments of village-scale slow sand filtration. *Progress in Water Technology, India*, 11:1, 159-165, 1979.
- Huisman, L. and W. E. Wood. Slow sand filtration. World Health Organization, Geneva, 122 p., 1974.
- Jakubowski, W. and Hoff, J. C. Waterborne Transmission of Giardia. USEPA, Cincinnati, Ohio, Report No. EPA 600/9-79-001, 1979.
- Johnson, J. G. Advanced filtration techniques. *Effluent & Water Treatment Journal (U.K.)*, "Insight", 52-56, 1978.
- Jorden, R. M. Electrophoretic studies of filtration. *Journal of American Water Works Association*, 55:6, 771-782, 1963.
- Kirner, J. C., Littler, J. D. and Angelo, L. A. "A Waterborne Outbreak of Giardiasis in Camas, Washington." J. of Am. Water Works Assoc., 70:1 35-40, Jan. 1978.
- Lippy, E. C. "Tracing a Giardiasis Outbreak in Berlin, New Hampshire." J. of Am. Water Works Assoc., 74:5, 249-256, May, 1982.
- Luchtel, D. L., Lawrence, W. P., and DeWalle, F. B., Electron Microscopy of Giardia lamblia Cysts. Appl. and Envir. Micro., 40(4):821-832, 1980.
- McCarthy, W. J. Construction and development of slow sand filters at Lawrence, Mass. *Journal of New England Water Works Association*, 89:1, 36-43, 1975.

- Metcalf and Eddy Inc., Wastewater Engineering: Treatment, Disposal, Reuse, Second Edition, McGraw Hill, New York, 1979.
- Miller, S. Drinking water and its treatment. Environmental Science and Technology, 14:5, 510-512, 514, May, 1980.
- Notermans, S.; A. H. Havelaar and J. Schellart. The occurrence of Clostridium botulinum in raw-water storage areas and their elimination in water treatment plants. Water Research, 14:11, 1631-1635, November, 1980.
- Okun, D. A. Water supply and treatment in three European countries. Journal of American Water Works Association, 54:6, 650-656, June, 1962.
- Paramasivam, R.; V. A. Mhaisalkar and P. M. Berthouex. "Slow sand filter design and construction in developing countries." Journal of American Water Works Association, 73:4, 178-185, April, 1981.
- Paramasivam, R.; D. S. Tajne; . S. Dhage and N. S. Joshi. Effect of intermittent operation of slow sand filters on filtered water quality. Indian Journal of Environmental Health, 22:2, 136-150, 1980.
- Pavoni, J. L., Tenny, M. W., and Echelberger, W. F., Jr., "Bacterial Exocellular Polymers and Biological Flocculation," Journal Water Pollution Control Federation, Vol. 44, No. 3, 414-418, 1972.
- Poynter S. F. b. and Slade, J. S. The removal of virus by slow sand filtration. Progress in Water Technology, 9:1, 75-88, 1977.
- Rendtorff, R. C. The Experimental Transmission of Human Intestinal Protozoan Parasites: Giardia lamblia Cysts Given in Capsules. Am. J. Hyg., 59:209-220, 1954.
- Report of the Filtration Commission of the City of Pittsburgh, PA. 1899.
- Schalekamp, M. The effectiveness of rapidly operated slow filters and a new cleaning process. Proceedings AWWA 95th Annual Conference, Minneapolis, MN, June 8-13, 1975.
- Schoettler, U. Elimination of trace-elements by slow-sand filtration. Zeitschrift Fuer Wasser und Abwasser Forschung, 9:3, 88-93, 1976.
- Schottler, U. and C. Nahle. Beryllium in natural filtration systems. Zeitschrift fur Wasser und Abwasser Forschung, 12:1, 21-25, 1979.
- Shaw, P. K., Brodsky, R. E., Lyman, D. O., Wood, B. T., Hibler, C. P., Healy, G. R., Macleod, K. I. E., Stahl, W. and Schultz, M. G. "A Community-Wide Outbreak of Giardiasis wth Evidence of Transmissio by a Municipal Water Supply." Annals Intr. Med., 87:4, 426-432, 1977.



Slade, J. S. Enteroviruses in slow sand filtered water. Journal of Institution of Water Engineers and Scientists, 32:6, 530-536, 1978.

Slezak, L. A.; R. C. Sims and V. D. Adams. Current application and applicability of slow rate sand filtration in the United States. Presented at 103rd Annual AWWA Conference, Las Vegas, NV, June 7, 1983.

Sundaresan, B. B. S.S.F. research and demonstration project on slow sand filtration. International Reference Centre for Community Water Supply and Sanitation WHO Collaborating Centre, Occasional Paper No. 3, December.

Taylor, E. A. Forty-fifth report on the results of the bacteriological, chemical and biological examination of the London waters for the years 1971-1973. Metropolitan Water Board, New River Head, Rosebery Avenue, London E1R 4TP, 19xx.

Vaillant, C. J. Simple water treatment processes (with special reference to filtration and disinfection). Aqua (Netherlands) No. 4, 1982.

WHO Collaborating Center. Slow sand filtration or community water supply in developing countries. Report of an International Appraisal Meeting, Nagpur, India, Bulletin Series 16, September 15-19, 1980.

## APPENDIX A

### Results of Phase I Experiments for Slow Sand Filtration 7/1981 - 1/1983

The following three tables, Tables A-1, A-2, and A-3 contain all of the Phase I experimental results obtained from three laboratory scale slow sand filters, operated continuously at hydraulic loading rates of  $v = 0.04$  m/hr,  $0.12$  m/hr, and  $0.40$  m/hr, respectively, over the period July 1981 to January 1983. These tables contain the raw data collected for *Giardia* cysts, total coliform bacteria, fecal coliform bacteria, standard plate count bacteria, turbidity and particle count testing. The tables in this appendix can be cross-referenced by date with Figures I-1, I-2, and I-3, of Appendix I, which contain corresponding graphical histories of temperature hydraulic loading rate and differential pressure.

Table A-1. Results of Experiments for Slow Sand Filter No. 1, v = 0.04 m/h (page 1 of 9)

DATE	RUN TEMP NO. (°C)	AGE OF SOIL DECKE (WEEKS)	STANDARD		TOTAL COLIFORM CONCENTRATION (COLIF./100ML)	FECAL COLIFORM CONCENTRATION (COLIF./100ML)	TURBIDITY (NTU)	PARTICLE COUNT CONCENTRATION (NO./10ML)	INFLUENT		NUMBER OF CYSTS DETECTED IN ANALYSIS
			FLATE COUNT CONCENTRATION (NO./ML)	INFLUENT GIARDIA CYST CONCENTRATION (CYSTS/L)					EFFLUENT GIARDIA VOLUME SAMPLED (L)	EFFLUENT METHOD	
27 8 81	8 15	0					4.4		1.2		
28 8 81	8 15						4.4		0.9		
29 8 81	8 15						3.9		1.6		
30 8 81	8 15						4.0		2.6		
1 9 81	8 15						4.1		2.4		
2 9 81	8 15	1					4.1		2.5		
3 9 81	10 15	1		92000.			6.4		3.4		
4 9 81	10 15	1		75000.	1500.		4.2		3.6		
5 9 81	12 15	1			3100.		4.5		2.7		
6 9 81	12 15						4.4		2.8		
7 9 81	12 15						4.7		5.8		
8 9 81	12 15						4.5		8.0		
9 9 81	12 15						4.5		6.3		
10 9 81	12 15						4.6		5.7		
11 9 81	12 15						4.6		7.8		
12 9 81	12 15						5.0		7.6		
13 9 81	12 15						4.9		5.9		
14 9 81	12 15						5.8		4.6		
17 9 81	12 15						6.0		5.4		
18 9 81	12 15						5.8		4.3		
19 9 81	12 15						5.9		4.4		
20 9 81	12 15						5.5		4.4		
21 9 81	12 15	4					5.1		4.1		
23 9 81	15 15	4					5.8		4.2		
24 9 81	15 15	4					5.6		4.7		
25 9 81	18 15	4		28900.			5.7		4.7		
26 9 81	18 15	4		100000.	6.		5.8		4.6		
27 9 81	21 15	5					5.9		4.7		
28 9 81	21 15						6.2		4.5		
29 9 81	21 15						7.0		4.0		
30 9 81	21 15						7.1		4.5		
1 10 81	21 15						6.4		4.4		
2 10 81	21 15	5					6.5		4.6		
3 10 81	24 5	5		80.			6.5		4.5		
4 10 81	24 5			390.	0.		6.8		4.7		
5 10 81	24 5			290.	5.		6.6		3.8		
6 10 81	24 5			70.	0.		6.8		3.9		
7 10 81	24 5	6			0.		7.0		4.0		

Table A-1. Results of Experiments for Slow Sand Filter No. 1, v = 0.04 m/h (page 2 of 9)

DATE	RUN TEMP NO.	TEMP (°C)	AGE OF DECKE (WEEKS)	STANDARD PLATE COUNT		TOTAL COLIFORM CONCENTRATION (COLIF./100ML)	FECAL COLIFORM CONCENTRATION (COLIF./100ML)	TURBIDITY (NTU)	PARTICLE COUNT CONCENTRATION (NO./10ML)	INFLUENT		NUMBER OF CYSTS OF GIARDIA DETECTED IN ANALYSIS OF EFFLUENT SAMPLED	
				INFLUENT CONCENTRATION (NO./ML)	EFFLUENT CONCENTRATION (NO./ML)					GIARDIA CYST CONCENTRATION (CYSTS/L)	EFFLUENT VOLUME SAMPLED (L)		
9 10 81	27	15	6					6.3			4.2		
10 10 81	27	15						6.3				4.5	
11 10 81	27	15						6.5				5.0	
12 10 81	27	15						6.6				4.2	
13 10 81	27	15						6.5				4.3	
14 10 81	27	15						6.7				4.1	
15 10 81	27	15						6.4				4.3	
16 10 81	27	15						6.8				3.8	
17 10 81	27	15						6.8				3.9	
18 10 81	27	15						6.7				4.5	
19 10 81	27	15						6.9				4.7	
20 10 81	27	15						7.0				4.7	
21 10 81	27	15						6.8				5.3	
22 10 81	27	15						7.0				4.7	
23 10 81	27	15						6.8				4.6	
24 10 81	27	15						6.5				4.6	
25 10 81	27	15						6.6				4.7	
26 10 81	27	15						6.6				5.7	
27 10 81	27	15						6.7				6.1	
28 10 81	27	15						6.4				5.1	
29 10 81	27	15		9				6.5				5.6	
30 10 81	30	5		9		22300.		6.6				5.1	
31 10 81	30	5				24200.		6.4				5.3	
1 11 81	30	5				28000.		6.1				5.5	
2 11 81	30	5				32300.		6.2				5.1	
3 11 81	30	5				39000.		6.3				5.8	
4 11 81	30	5		10		4000.		6.2				4.6	
6 11 81	33	15		10		480.		6.3				4.7	
7 11 81	33	15				280.		6.3				4.8	
8 11 81	33	15				1900.		6.5				4.7	
9 11 81	33	15			40000.		6.3				4.8		
10 11 81	33	15			10000.		6.7				3.8		
11 11 81	33	15	11				6.7				4.0		
12 11 81	33	15	11				6.7				4.7		
13 11 81	36	15					6.4				3.6		
14 11 81	36	15					6.5				4.2		
15 11 81	36	15					6.7				4.9		
16 11 81	36	15					6.4				4.7		
17 11 81	36	15					6.5				4.3		
18 11 81	36	15	12				6.5				4.3		

Table A-1. Results of Experiments for Slow Sand Filter No. 1,  $v = 0.04$  m/h (page 3 of 9)

DATE	RUN NO.	TEMP (°C)	AGE OF DECKE (WEEKS)	STANDARD		TOTAL COLIFORM CONCENTRATION (COLIF./100ML)	FECAL COLIFORM CONCENTRATION (COLIF./100ML)	TURBIDITY (NTU)	PARTICLE COUNT CONCENTRATION (NO./10ML)	INFLUENT GIARDIA CYST CONCENTRATION (CYSTS/L)	EFFLUENT VOLUME SAMPLED (L)	NUMBER OF CYSTS DETECTED IN ANALYSIS
				PLATE COUNT (NO./ML)	INFLUENT GIARDIA CYST CONCENTRATION (CYSTS/L)							
19	11	81	39	15	12			6.2			5.4	
20	11	81	39	15				6.9			5.0	
21	11	81	39	15				6.3			4.4	
22	11	81	39	15				5.9			3.9	
23	11	81	39	15				6.3			3.9	
24	11	81	39	15				6.6			4.5	
25	11	81	39	15				6.5			4.3	
29	11	81	39	15				6.3			5.3	
30	11	81	39	15				6.4			5.3	
1	12	81	39	15				6.6			5.3	
2	12	81	39	15				7.1			3.9	
3	12	81	39	15				7.2			4.7	
4	12	81	39	15				6.8			3.9	
5	12	81	39	15				7.0			4.6	
6	12	81	39	15				7.0			4.7	
7	12	81	39	15				7.2			4.0	
8	12	81	39	15				6.7			5.2	
9	12	81	39	15				7.1			3.9	
10	12	81	39	15	15			7.1			4.4	
11	12	81	42	15	15			8.6			5.4	
12	12	81	42	15				8.8			5.4	
13	12	81	42	15				8.6			5.6	
14	12	81	42	15	16			8.9			5.7	
15	12	81	45	15	16			8.7			6.6	
16	12	81	45	15				8.8			6.0	
17	12	81	45	15				8.8			5.6	
18	12	81	45	15				9.1			7.0	
20	12	81	45	15				8.9			3.8	
22	12	81	45	15				8.7			3.7	
23	12	81	45	15				9.5			3.7	
27	12	81	45	15				8.9			4.5	
31	12	81	45	15				8.9			3.5	
4	1	82	45	15				8.8			3.2	
8	1	82	45	15				7.9			2.4	
10	1	82	45	15				8.0			2.3	
15	1	82	45	15				8.2			2.8	
18	1	82	45	15				8.1			3.4	
22	1	82	45	15				8.7			3.3	
25	1	82	45	15				9.2			3.2	
28	1	82	45	15				10.5			5.0	

Table A-1. Results of Experiments for Slow Sand Filter No. 1, v = 0.04 m/h (page 4 of 9)

DATE	RYN	TEMP	SCHWITZ-	AGE OF	STANDARD		INFLUENT EFFLUENT		INFLUENT EFFLUENT		INFLUENT EFFLUENT		INFLUENT		EFFLUENT DETECTED		NUMBER		
					NO.	(°C)	NO./ML	CONCENTRATION	NO./100ML	CONCENTRATION	NO./100ML	CONCENTRATION	NO./100ML	CONCENTRATION	CONCENTRATION	CONCENTRATION		CONCENTRATION	CONCENTRATION
MO	HR			DECKE															
				(WEEKS)														(L)	(NO.)
30	1	82	45	15															
2	2	82	45	15															
3	2	82	45	15															
4	2	82	45	15															
5	2	82	45	15															
6	2	82	45	15															
7	2	82	45	15															
8	2	82	45	15															
9	2	82	45	15															
10	2	82	45	15															
11	2	82	45	15															
12	2	82	45	15															
13	2	82	45	15															
14	2	82	45	15															
15	2	82	45	15															
16	2	82	45	15															
18	2	82	45	15															
20	2	82	45	15															
26	2	82	48	5															
27	2	82	48	5															
28	2	82	48	5															
1	3	82	48	5															
2	3	82	48	5															
3	3	82	48	5															
4	3	82	51	15															
5	3	82	51	15															
9	3	82	51	15															
10	3	82	51	15															
11	3	82	51	15															
12	3	82	51	15															
13	3	82	51	15															
14	3	82	51	15															
15	3	82	51	15															
16	3	82	51	15															
17	3	82	51	15															
18	3	82	54	15															
19	3	82	54	15															
20	3	82	54	15															
21	3	82	54	15															
22	3	82	54	15															
23	3	82	54	15															

Table A-1. Results of Experiments for Slow Sand Filter No. 1, v = 0.04 m/h (page 5 of 9)

DATE	RUN NO.	TEMP (°C)	AGE OF DECKE (WEEKS)	STANDARD		TURBIDITY (NTU)	FECAL COLIFORM CONCENTRATION (CO.F./100ML)	TOTAL COLIFORM CONCENTRATION (CO.F./100ML)	PARTICLE COUNT CONCENTRATION (NO./10ML)	INFLUENT GIARDIA CYST CONCENTRATION (CYSTS/L)	EFFLUENT VOLUME SAMPLED (L)	NUMBER OF CYSTS DETECTED IN ANALYSIS	GIARDIA ANALYSIS METHOD
				PLATE COUNT CONCENTRATION (NO./ML)	INFLUENT EFFLUENT								
24	3 82	57	15	4		3.6							
26	3 82	57	15			3.4							
29	3 82	57	15			3.4							
31	3 82	57	15	5		4.2							
1	4 82	60	5	5	21900.	4.0	160.		5811.	500	327	-	ZF
2	4 82	60	5		24300.	4.1	98.	8400.	1500.	500	278	16	ZF
3	4 82	60	5		19000.	3.7	130.	16500.	172.	500	828	13	ZF
4	4 82	60	5		15100.	4.0	70.	11000.	1697.	500	164	13	ZF
5	4 82	60	5		10400.	3.7	0.	15000.	198.	0	0	18	ZF
6	4 82	60	5	6	3110.	3.9	0.	660.	90.	-	-	21	ZF
7	4 82	63	15	6		3.4							
8	4 82	63	15			3.2							
10	4 82	63	15			2.9							
12	4 82	63	15			2.8							
14	4 82	63	15			2.7							
17	4 82	63	15			3.5							
19	4 82	63	15			4.0							
21	4 82	63	15			5.0							
23	4 82	63	15			4.8							
26	4 82	63	15			4.9							
28	4 82	63	15			4.2							
30	4 82	63	15			5.1							
3	5 82	63	15			4.9							
5	5 82	63	15			5.7							
7	5 82	63	15			4.4							
10	5 82	63	15			4.3							
12	5 82	63	15			4.1							
14	5 82	63	15	11		4.4							
17	5 82	66	15	12	5800.	5.0				50	66.7	-	ZF
18	5 82	66	15		1010000.	5.2				50	53.2	7	ZF
19	5 82	66	15		6400.	5.4				50	14.5	22	ZF
20	5 82	66	15		8500.	5.3				50	42.6	28	ZF
21	5 82	66	15		23300.	4.5				50	10.4	25	ZF
22	5 82	66	15		68000.	4.4	0.	0.		50	7.1	25	ZF
23	5 82	66	15		22200.	4.5	0.	5.		50	56.3	28	ZF
24	5 82	66	15	11	28100.	4.4	0.	10.		50	0.6	40	ZF
25	5 82	69	5	13	10300.	4.4	0.	14.		50	21.4	34	ZF
26	5 82	69	5		13200.	4.3	0.	49.		50	95.4	29	ZF
27	5 82	69	5		2900.	4.4	0.	26.	1150.	50	21.1	24	ZF
28	5 82	69	5		9100.	4.4	1.	52.	935.	50	17.9	28	ZF
29	5 82	69	5	13	1330.	4.4	0.	48.	12.5	-	-	25	ZF

Table A-1. Results of Experiments for Slow Sand Filter No. 1, v = 0.04 m/h (page 6 of 9)

DATE	DY MO YR	RUN NO.	TEMP (°C)	AGE OF DECKE (WEEKS)	STANDARD PLATE COUNT CONCENTRATION (NO./ML)		TOTAL COLIFORM CONCENTRATION (COLIF./100ML)	FECAL COLIFORM CONCENTRATION (COLIF./100ML)	TURBIDITY (NTU)	PARTICLE COUNT CONCENTRATION (NO./10ML)	INFLUENT GIARDIA CYST CONCENTRATION (CYSTS/L)	EFFLUENT GIARDIA ANALYSIS III	NUMBER OF CYSTS DETECTED	
					INFLUENT	EFFLUENT								
ADDED DETECTED														
VOLUME SAMPLED														
1	6	82	72	15	14	4200.	2700.	330.	3.9	1.8	50	8.7	-	2F
2	6	82	72	15		5100.			3.7	1.8	50	0.8	33	0
3	6	82	72	15		3020.		490.	3.8	2.7	50	0.9	31	0
4	6	82	72	15	14	2980.		1100.	3.8	2.7	50	31.1	31	0
5	6	82	75	15	0	12100.		1800.	3.7	2.5	50	16.6	26	0
6	6	82	75	15		7600.		1600.	3.8	2.4	50	20.4	25	0
7	6	82	75	15		2000.		0.	5.8	2.4	0	-	33	0
8	6	82	75	15		3450.	260.	26.	3.6	2.4				
9	6	82	75	15		5800.	262.	31.	3.5	2.4				
10	6	82	75	15		2670.	490.		3.5	1.6	50	18.0	-	2F
11	6	82	75	15		2265.	720.	29.	3.5	1.6	50	26.9	28	0
12	6	82	75	15		2725.	550.	66.	3.5	1.9	50	15.1	30	0
13	6	82	75	15		2520.	237.	118.	3.3	2.0	50	19.9	27	0
14	6	82	75	15		3910.	393.	190.	3.4	2.1	50	16.7	26	0
15	6	82	75	15	3	1430.	0.	0.	3.4	2.2	0	-	24	0
16	6	82	78	15	3	380.	145.		3.7	2.2				
17	6	82	78	15		1070.	155.							
18	6	82	78	15		800.	273.	148.	4.1	2.1				
19	7	82	78	15		640.	492.	20.						
20	7	82	78	15	4	1300.	11.	0.	1.8	2.2				
21	7	82	81	5	0	1785.	100.	0.	4.1	2.0	50	34.3	-	MP
22	7	82	81	5		2655.	67.	0.	4.1	2.3	50	56.0	28	0
23	7	82	81	5		2800.	71.	0.	4.4	2.7	50	29.1	26	0
24	7	82	81	5		2785.	31.	0.	4.4	2.8	50	26.7	24	0
25	7	82	81	5		2875.	1620.	37.	4.4	2.9	50	28.1	26	0
26	7	82	81	5		1790.	10.	0.	4.2	2.8	50	-	27	0
27	7	82	81	15					3.3	2.3				
28	7	82	81	15					3.4	1.9				
29	7	82	81	15					3.5	1.8				
30	7	82	81	5		800.	23.	0.	3.5	1.6	50	16.6	-	MP
31	7	82	81	5		845.	18.	0.	3.5	1.7	50	30.0	24	0
32	7	82	81	5		1390.	290.	17.	3.5	1.9	50	15.7	23	0
33	7	82	81	5		2045.	465.	20.	3.5	2.0	50	13.6	22	0
34	7	82	81	5		1290.	535.	1.	3.5	2.1	50	58.2	-	MP
35	7	82	81	5	3				3.7	2.1	50	45.6	144	0



Table A-1. Results of Experiments for Slow Sand Filter No. 1, v = 0.04 m/h (page 7 of 9)

DATE	RII NO.	TEMP (°C)	AGE OF SUMP/2-DUCKE (MEEKS)	STANDARD		TOTAL COLIFORM CONCENTRATION (COLIF./100ML)	FECAL COLIFORM CONCENTRATION (COLIF./100ML)	TURBIDITY (NTU)	PARTICLE COUNT CONCENTRATION (NO./10ML)	INFLUENT		NUMBER OF CYSTS OF GIARDIA
				PLATE COUNT CONCENTRATION (NO./ML)	CONCENTRATION (CYSTS/L)					GIARDIA CYST CONCENTRATION (CYSTS/L)	EFFLUENT VOLUME SAMPLED (L)	
RY MO YR				INFLUENT	EFFLUENT	INFLUENT	EFFLUENT	INFLUENT	EFFLUENT	ADDED	DETECTED	ANALYSIS METHOD
25 7 82	84	15	3	20000.	270.	4400.	0.	3.6	2.0	1000	123	MP
26 7 82	84	15		4400.	230.	600.	0.	4.0	1.9	1000	173	MP
27 7 82	84	15		1600.	260.	700.	0.	4.1	1.7	0	29	MP
28 7 82	84	15		4500.	40.	4300.	2.	4.1	1.8	1000	256	MP
30 7 82	84	15	4	4400.	630.	650.	0.	3.9	1.7	1000	183	MP
1 8 82	87	15	4	66000.	74000.			5.0	2.0	0	27	MP
2 8 82	87	15	4	66000.	2620.	71000.	1.	5.0	2.0	1000	167	MP
3 8 82	87	15		300.	300.		0.	5.0	2.1	0	28	MP
4 8 82	87	15		15800.	2900000.			5.0	2.1	1000	256	MP
5 8 82	87	15		10700.	260.	210000.	0.	4.8	2.1	1000	183	MP
6 8 82	87	15	5	4500.	410.		1.	5.2	2.2	0	27	MP
8 8 82	90	15	5	6300.	3480.	13000.	0.	4.8	1.9	1000	167	MP
9 8 82	90	15		17100.	85.	13800.	8.	4.8	2.1	1000	220	MP
10 8 82	90	15		39900.	176.	17000.	5.	5.6	2.2	1000	160	MP
11 8 82	90	15		7100.	131.		2.	5.6	2.3	1000	258	MP
12 8 82	90	15	6	5800.	230.	2050.	1.	5.2	2.1	1000	300	MP
16 8 82	92	15	6	550.	95.	1600.	4.	5.1	1.8			
17 8 82	92	15				75.	4.	5.0	2.0			
18 8 82	92	15						5.1	2.1			
20 8 82	92	15	7					5.1	2.2			
24 8 82	95	15						5.2	2.0			
27 8 82	95	15						5.5	3.8			
31 8 82	95	15						6.4	3.4			
3 9 82	95	15						6.5	3.2			
7 9 82	95	15						6.7	2.9			
10 9 82	95	15						6.7	2.8			
13 9 82	95	15						6.9	2.8			
16 9 82	95	15						7.2	2.6			
18 9 82	95	15						7.5	2.7			
21 9 82	95	15						7.6	2.6			
24 9 82	95	15	12									

Table A-1. Results of Experiments for Slow Sand Filter No. 1,  $v = 0.04$  m/h (page 8 of 9)

DATE	RUN NO.	TEMP (°C)	AGE OF FILTER (WEEKS)	STANDARD PLATE COUNT		TOTAL COLIFORM CONCENTRATION (COLIF./100ML)	FECAL COLIFORM CONCENTRATION (COLIF./100ML)	TURBIDITY (NTU)	PARTICLE COUNT CONCENTRATION (NO./10ML)	INFLUENT GIARDIA CYST CONCENTRATION (CYSTS/L)	EFFLUENT GIARDIA CYST CONCENTRATION (CYSTS/L)	EFFLUENT VOLUME SAMPLED (L)	NUMBER OF CYSTS DETECTED IN ANALYSIS
				INFLUENT (NO./ML)	EFFLUENT (NO./ML)								
28 9 82	98	15	12	2250.	21000.			9.0	2.8				
29 9 82	98	15		3500.	11200.	4.							
30 9 82	98	15		2700.	390.	32000.	6.	7.9	3.4				
1 10 82	98	15		3350.	220.	7000.	7.	6.9	3.7				
2 10 82	98	15		1100.	120.	4400.	10.	7.2	3.8				
3 10 82	98	15		2000.	330.	6000.	5.						
4 10 82	98	15		2675.	605.	21000.	4.	7.8	3.6				
5 10 82	98	15		2800.	366.	26500.	4.						
6 10 82	98	15		2005.	197.	20000.	1.	7.4	3.7				
7 10 82	98	15		2340.	660.	500.	1.	7.1	3.6				
8 10 82	98	15		3600.	860.	145.							
9 10 82	98	15			210.								
10 10 82	98	15						7.1	3.7				
11 10 82	98	15		10250.	47500.								
12 10 82	98	15		1700.	1075.	1150.	0.	7.3	3.5				
13 10 82	98	15		2800.	12500.								
14 10 82	98	15						8.0	3.6				
15 10 82	98	15		2350.	1080.	700.	1.						
16 10 82	98	15		165.	165.	0.							
18 10 82	98	15	15					7.5	3.8				
20 10 82	101	15	16	19400.	600.			7.8	3.8	1000	720		MP
21 10 82	101	15		29750.	355.	13000.	0.	7.8	4.4	1173	986	23	MP
22 10 82	101	15		670.	110.	3.	2.	7.6	4.6	0		38	MP
23 10 82	101	15		600.	120.	4.	1.	7.6	4.7	0		27	MP
24 10 82	101	15		650.	139.	1.	0.	7.6	4.5	0		24	MP
25 10 82	101	15	16	420.	141.	2.	0.	7.7	4.6	0		26	MP
26 10 82	104	15	16	4400.	23500.			8.4	4.9	5000	2060		MP
27 10 82	104	15		7750.	61.	22500.	1.	8.0	4.6	5150	3350	23	MP
28 10 82	104	15		995.	180.	1.	2.	8.1	4.5	0		36	MP
29 10 82	104	15		1400.	75.	1.	0.	8.2	4.6	0		48	MP
30 10 82	104	15		450.	300.	3.	0.	8.3	4.5	0		32	MP
31 10 82	104	15		955.	115.	2.	0.	8.0	4.6	0		32	MP
1 11 82	104	15		13.	122.	2.	1.						
2 11 82	104	15	17	800.	215.	3.	0.	7.8	4.7				
3 11 82	107	15	0	16500.	2750.	20000.	0.	8.1	5.0	1505	784		MP
4 11 82	107	15		27000.	525.	24000.	6.	8.1	5.2	1500	668	28	MP
5 11 82	107	15		315.	35.	3.	7.	8.9	5.8	0		45	MP
6 11 82	107	15		126.	50.	0.	1.	8.9	5.8	0		26	MP
7 11 82	107	15		144.	71.	0.	1.	9.1	6.3	0		43	MP
8 11 82	107	15		111.	54.	1.	1.						
9 11 82	107	15	1	327.	64.	1.	0.						

Table A-1. Results of Experiments for Slow Sand Filter No. 1, v = 0.04 m/h (page 9 of 9)

DATE	RUN NO.	TEMP (°C)	AGE OF DECK (WEEKS)	STANDARD			TURBIDITY (NTU)	PARTICLE COUNT CONCENTRATION (NO./10ML)	INFLUENT GIARDIA CYST CONCENTRATION (CYSTS/L)	EFFLUENT GIARDIA ANALYSIS	
				FLATE COUNT CONCENTRATION (NO./ML)	TOTAL COLIFORM CONCENTRATION (COLIF./100ML)	FECAL COLIFORM CONCENTRATION (COLIF./100ML)					
12 11 82	110	15	0	37500.	20500.	10.9	8.1	1982	1250	-	MP
13 11 82	110	15		29100.	15500.	10.2	8.9	1923	1863	26	MP
14 11 82	110	15		210.	6.	9.9	8.4	0	-	37	MP
15 11 82	110	15		10.	1.	9.6	7.8	0	-	75	MP
16 11 82	110	15		82.	1.	9.7	7.4	0	-	38	MP
17 11 82	110	15		110.	0.	10.2	7.1	0	-	-	-
18 11 82	110	15		3010.	0.	9.5	6.7	0	-	-	-
19 11 82	110	15	1	1120.	0.	10.4	6.2	0	-	-	-
22 11 82	113	15	2			9.7	5.4				
24 11 82	113	15				10.0	5.1				
26 11 82	113	15				9.6	5.2				
29 11 82	113	15				9.8	4.8				
1 12 82	113	15				10.1	4.5				
3 12 82	113	15	3			10.4	4.3				
7 12 82	116	15	0	11800.	29500.	10.7	14.5	3692	2433	-	MP
8 12 82	116	15		166500.	24000.	10.6	12.6	3692	4507	98	MP
9 12 82	116	15		5600.	1270.	9.5	10.9	0	-	138	MP
10 12 82	116	15		20300.	960.	9.5	10.8	0	-	111	MP
11 12 82	116	15		13700.	230.	9.8	12.3	0	-	150	MP
12 12 82	116	15		10800.	1.	9.8	12.9	0	-	-	-
13 12 82	116	15		2550.	0.	5.	-	-	-	-	-
14 12 82	116	15	1	530.	0.	2.	-	-	-	-	-
18 1 83	118	15	0	19500.	39000.	10.1	10.8	2000	2100	-	MP
19 1 83	118	15		80000.	42000.	9.9	10.1	2000	1458	127	1180
20 1 83	118	15		72000.	52500.	9.9	10.2	2000	1282	115	2060
21 1 83	118	15		60000.	39000.	10.0	9.2	2000	970	139	1920
22 1 83	118	15		19500.	970.	9.6	8.9	0	-	127	1330
23 1 83	118	15		3700.	180.	9.2	9.1	0	-	102	1000
24 1 83	118	15		960.	0.	9.7	8.9	0	-	-	-
26 1 83	118	15	1	290.	0.	21.	-	-	-	-	-

1/ those high numbers of cysts detected in effluent were due to replacing the biological mature sand and gravel support with new sand and new gravel support.

Table A-2. Results of experiments for slow sand Filter No. 2, v = 0.12 m/h (page 1 of 10).

DATE	RUN NO.	TEMP (°C)	AGE OF DECK (WEEKS)	STANDARD		TOTAL COLIFORM CONCENTRATION (COLIF./100ML)	FECAL COLIFORM CONCENTRATION (COLIF./100ML)	TURBIDITY (NTU)	PARTICLE COUNT CONCENTRATION (NO./10ML)	INFLUENT GIARDIA CYST CONCENTRATION (CYSTS/L)	EFFLUENT GIARDIA CYST CONCENTRATION (CYSTS/L)	EFFLUENT VOLUME SAMPLED (L)	NUMBER OF CYSTS DETECTED IN EFFLUENT ANALYSIS METHOD
				FLATE COUNT (NO./PL)	INFLUENT EFFLUENT								
1 7 81	3	15	0					5.2	3.5				
2 7 81	3	15						7.5	3.5				
4 7 81	3	15						5.5	4.3				
6 7 81	3	15						4.2	4.3				
7 7 81	3	15						4.5	3.7				
8 7 81	3	15	1					5.4	4.1				
26 7 81	4	5	4		770000.	100000.		11.0	3.8				
27 7 81	4	5	4					4.5	3.5				
28 7 81	5	15	4			20000.		3.7	3.7				
29 7 81	5	15						3.6	3.6				
30 7 81	5	15						3.9	3.8				
31 7 81	5	15						3.9	3.6				
1 8 81	5	15						3.6	3.5				
2 8 81	5	15						3.6	3.5				
4 8 81	5	15						3.9	3.6				
5 8 81	5	15						3.7	3.7				
6 8 81	5	15						3.9	3.7				
7 8 81	5	15						4.2	3.1				
9 8 81	5	15						3.9	3.5				
10 8 81	5	15						3.4	3.3				
11 8 81	5	15						3.8	3.4				
12 8 81	5	15	6					3.6	3.3				
13 8 81	6	5	6		80000.	0.		5.0	3.3				
14 8 81	6	5	6		47000.	3000.		5.0	3.0				
15 8 81	7	15	7		9300.	800.		4.1	3.0				
17 8 81	7	15				220.		3.7	3.9				
18 8 81	7	15						3.8	3.8				
19 8 81	7	15						3.8	3.8				
20 8 81	7	15						3.7	3.7				
21 8 81	7	15			3.	0.		3.7	3.6				
22 8 81	7	15						7.8	3.4				
24 8 81	7	15						5.9	4.8				
25 8 81	7	15						6.0	3.9				
26 8 81	7	15						4.0	3.4				
27 8 81	7	15						4.0	2.5				
28 8 81	7	15						4.0	2.0				
29 8 81	7	15						3.9	1.9				
30 8 81	7	15						4.0	1.7				

Table A-2. Results of experiments for slow sand Filter No. 2,  $v = 0.12$  m/h (page 2 of 10).

DATE	RUN NO.	TEMP (°C)	AGE OF DECKE (WEEKS)	STANDARD		TURBIDITY (NTU)	PARTICLE COUNT CONCENTRATION (NO./10ML)	INFLUENT GIARDIA CYST CONCENTRATION (CYSTS/L)	EFFLUENT VOLUME SAMPLED (L)	NUMBER OF CYSTS DETECTED IN EFFLUENT ANALYSIS
				PLATE COUNT CONCENTRATION (NO./ML)	FLUORESCENT CONCENTRATION (COLIF./100ML)					
BY MO YR				INFLUENT	EFFLUENT	INFLUENT	EFFLUENT	ADDED	DETECTED	(NO.)
1	9 81	7 15				4.1				1.7
2	9 81	7 15				4.0				1.6
3	9 81	7 15				4.1				1.7
4	9 81	7 15				4.4				1.8
5	9 81	7 15				4.2				1.8
6	9 81	7 15				4.3				1.7
7	9 81	7 15				4.7				1.7
8	9 81	7 15				4.4				1.9
9	9 81	7 15				4.5				1.8
10	9 81	7 15				4.6				1.9
11	9 81	7 15				4.6				3.4
12	9 81	7 15				5.0				3.5
13	9 81	7 15				4.9				4.0
14	9 81	7 15				5.8				4.3
17	9 81	7 15				6.0				4.6
18	9 81	7 15				5.8				4.8
19	9 81	7 15				5.9				4.6
20	9 81	7 15				5.5				4.6
21	9 81	7 15	12			5.4				4.6
22	9 81	14 15	12			7.2				4.6
23	9 81	14 15				5.8				2.8
24	9 81	14 15	12			5.6				3.3
25	9 81	17 15	12		28900.	5.7				5.2
26	9 81	17 15	13		100000.	5.8				5.1
27	9 81	20 15	13			5.9				4.7
28	9 81	20 15				6.2				4.2
29	9 81	20 15				7.0				4.4
30	9 81	20 15				7.1				4.1
1	10 81	20 15				6.4				3.4
2	10 81	20 15	13			6.5				5.1
3	10 81	23 5	14		80.	6.5				5.0
4	10 81	23 5			390.	6.8				5.3
5	10 81	23 5			290.	6.6				5.0
6	10 81	23 5			70.	6.8				5.1
7	10 81	23 5	14		3.	7.0				5.2

Table A-2. Results of experiments for slow sand Filter No. 2, v = 0.12 m/h (page 3 of 10).

DATE	RHH TEMP NO.	TEMP (°C)	AGE OF SCIMITZ-DECKE (WEEKS)	STANDARD PLATE COUNT (NO./ML)		TOTAL COLIFORM CONCENTRATION (COLIF./100ML)		FECAL COLIFORM CONCENTRATION (COLIF./100ML)		TURBIDITY (NTU)	PARTICLE COUNT CONCENTRATION (NO./10ML)	INFLUENT GIARDIA CYST CONCENTRATION (CYSTS/L)	EFFLUENT GIARDIA CYST CONCENTRATION (CYSTS/L)	EFFLUENT VOLUME SAMPLED (L)	NUMBER OF CYSTS DETECTED IN ANALYSIS PERIOD	
				INFLUENT	EFFLUENT	INFLUENT	EFFLUENT	INFLUENT	EFFLUENT							ADDED
9 10 81	26	15	14							6.3				4.5		
10 10 81	26	15									6.3				4.5	
11 10 81	26	15									6.5				5.1	
12 10 81	26	15									6.9				5.2	
13 10 81	26	15									6.6				5.2	
14 10 81	26	15									6.5				5.4	
15 10 81	26	15									6.7				5.5	
16 10 81	26	15									6.4				5.4	
17 10 81	26	15									6.8				5.5	
18 10 81	26	15									6.8				5.6	
19 10 81	26	15									6.7				5.7	
20 10 81	26	15									6.9				5.2	
21 10 81	26	15									7.0				5.5	
22 10 81	26	15									6.8				5.3	
23 10 81	26	15								7.0				5.3		
24 10 81	26	15								6.8				5.3		
25 10 81	26	15								6.5				5.3		
26 10 81	26	15								6.6				5.7		
27 10 81	26	15								6.6				6.1		
28 10 81	26	15								6.7				6.1		
29 10 81	26	15	17							6.4				5.1		
30 10 81	29	5	17			22300.				6.5				5.6		
31 10 81	29	5				24200.				6.6				4.8		
1 11 81	29	5				28000.				6.4				5.9		
2 11 81	29	5				32300.				6.1				5.9		
3 11 81	29	5				39000.				6.2				6.0		
4 11 81	29	5	18			4000.				6.3				6.3		
6 11 81	32	15	18							6.2				5.6		
7 11 81	32	15				480.				6.3				5.1		
8 11 81	32	15				280.				6.3				5.7		
9 11 81	32	15				1900.				6.5				5.3		
10 11 81	32	15				40000.				6.3				5.2		
11 11 81	32	15				10000.				6.7				4.5		
12 11 81	32	15	19							6.7				4.6		
13 11 81	35	15	19							6.7				4.0		
14 11 81	35	15								6.4				4.0		
15 11 81	35	15								6.5				4.8		
16 11 81	35	15								6.7				5.1		
17 11 81	35	15								6.4				4.8		
18 11 81	35	15	20							6.5				4.9		

Table A-2. Results of experiments for slow sand Filter No. 2, v = 0.12 m/h (page 4 of 10).

DATE	DY MO YR	RUI TEMP NO.	AGE OF DECKE (WEEKS)	STANDARD PLATE COUNT		TOTAL COLIFORM CONCENTRATION (COLIF./100ML)	FECAL COLIFORM CONCENTRATION (COLIF./100ML)	TURBIDITY (NTU)	PARTICLE COUNT CONCENTRATION (NO./10ML)	INFLUENT GIARDIA CYST CONCENTRATION (CYSTES/L)		EFFLUENT VOLUME SAMPLED (L)	NUMBER OF CYSTS DETECTED IN ANALYSIS	EFFLUENT METHOD
				INFLUENT CONCENTRATION (NO./ML)	EFFLUENT CONCENTRATION					ADDED	DETECTED			
19 11 81	38 15		20					6.2			5.5			
20 11 81	38 15							6.9			5.4			
21 11 81	38 15							6.3			3.6			
22 11 81	38 15							5.9			4.0			
23 11 81	38 15							6.3			4.2			
24 11 81	38 15							6.6			4.7			
25 11 81	38 15							6.5			4.7			
29 11 81	38 15							6.3			4.8			
30 11 81	38 15							6.4			4.7			
1 12 81	38 15							6.6			4.8			
2 12 81	38 15							7.1			4.6			
3 12 81	38 15							7.2			4.9			
4 12 81	38 15							6.8			4.6			
5 12 81	38 15							7.0			4.7			
6 12 81	38 15							7.0			5.0			
7 12 81	38 15							7.2			4.1			
8 12 81	38 15							6.7			5.1			
9 12 81	38 15							7.1			4.6			
10 12 81	38 15							7.0			4.5			
11 12 81	41 15		23					8.6			6.8			
12 12 81	41 15							8.8			7.8			
13 12 81	41 15							8.6			6.1			
14 12 81	41 15							8.6			4.9			
15 12 81	44 15							8.7			6.2			
16 12 81	44 15							8.8			6.0			
17 12 81	44 15							8.8			6.0			
18 12 81	44 15							9.1			7.2			
20 12 81	44 15							8.9			4.0			
22 12 81	44 15							8.7			3.9			
23 12 81	44 15							9.5			3.9			
27 12 81	44 15							8.9			4.2			
31 12 81	44 15							8.9			4.5			
4 1 82	44 15							8.8			3.8			
8 1 82	44 15							7.9			3.6			
10 1 82	44 15							8.0			4.0			
15 1 82	44 15							8.2			3.6			
18 1 82	44 15							8.1			4.1			
22 1 82	44 15							8.7			3.9			
25 1 82	44 15							9.2			4.0			
28 1 82	44 15							10.5			5.0			
30 1 82	44 15							11.0			4.4			

Table A-2. Results of experiments for slow sand Filter No. 2, v = 0.12 m/h (page 5 of 10).

DATE	RUN NO.	TEMP (°C)	AGE OF DECKE (WEEKS)	STANDARD PLATE COUNT (NO./PL)	TOTAL COLIFORM CONCENTRATION (COLIF./100ML)		FECAL COLIFORM CONCENTRATION (COLIF./100ML)	TURBIDITY (NTU)	PARTICLE COUNT CONCENTRATION (NO./10ML)	INFLUENT GIARDIA CYST CONCENTRATION (CYSTS/L)	EFFLUENT GIARDIA CYST CONCENTRATION (CYSTS/L)	EFFLUENT VOLUME SAMPLED (L)	NUMBER OF CYSTS DETECTED IN ANALYSIS	GIARDIA ANALYSIS METHOD	
					INFLUENT	EFFLUENT									
2	2	82	44	15				11.0	3.8						
3	2	82	44	15	6200.										
4	2	82	44	15	9400.	21300.									
5	2	82	44	15	30000.	14000.									
6	2	82	44	15	6000.	20400.									
7	2	82	44	15	4100.	10200.									
8	2	82	44	15	6800.	3800.									
9	2	82	44	15	900.	2960.									
10	2	82	44	15	4400.	2600.									
11	2	82	44	15	2400.	4800.									
12	2	82	44	15	1200.	30000.									
13	2	82	44	15	1800.	6000.									
14	2	82	44	15	3200.	5900.									
15	2	82	44	15	200.	1190.									
16	2	82	44	15	7200.	2300.									
20	2	82	44	15				6.0	2.9						
26	2	82	47	5	360.		30000.	6.2	7.1						
27	2	82	47	5	300.	570.	700.	4.0	5.2	1769.	500	413		2F	
28	2	82	47	5	260.	500.	200.	4.7	4.1	1609.	290.	180	33	2F	
1	3	82	47	5	350.	1710.	1.	4.8	4.5	1720.	89.	36	33	2F	
2	3	82	47	5				5.0	4.6	1738.	81.	42	14	2F	
3	3	82	47	5	960.	420.	5.	4.7	4.5	922.	102	37	5	2F	
4	3	82	50	15				5.5	4.4	831.	43.	34	28	2F	
5	3	82	50	15				3.8	3.9						
9	3	82	50	15	1700.		35000.	3.8	3.5						
10	3	82	50	15				4.5	2.9						
11	3	82	50	15											
12	3	82	50	15											
13	3	82	50	15	176.										
14	3	82	50	15	300.	540.	500.	3.9	3.1						
15	3	82	50	15	157.	770.	160.	4.1	3.1						
16	3	82	50	15	350.	710.	160.	4.2	3.0						
17	3	82	50	15	312.	1050.	360.								
18	3	82	53	15	7900.	980.	6300.	4.5	3.0	1294.	500	1262.		2F	
19	3	82	53	15	8500.	400.	6100.	4.5	2.7	40506.	88.	500	665	0	2F
20	3	82	53	15	17900.	840.	4900.	4.6	2.7	12591.	38.	500	656	0	2F
21	3	82	53	15	40000.	8900.	3900.	4.4	2.4	7975.	60.	500	1965	16	2F
22	3	82	53	15	300.	330.	0.	3.6	2.2	553.	75.	44	0	2F	
23	3	82	53	15	460.	380.	0.	4.2	2.4	62.	55.	56	0	2F	



Table A-2. Results of experiments for slow sand Filter No. 2, v = 0.12 m/h (page 6 of 10).

DATE	RUN NO.	TEMP (°C)	AGE OF DECKE (WEEKS)	STANDARD PLATE COUNT CONCENTRATION (NO./ML)	TOTAL COLIFORM CONCENTRATION (COLIF./100ML)	FECAL COLIFORM CONCENTRATION (COLIF./100ML)	TURBIDITY (NTU)	PARTICLE COUNT CONCENTRATION (NO./10ML)	INFLUENT GIARDIA CYST CONCENTRATION (CYSTS/L)	INFLUENT VOLUME SAMPLED (L)	NUMBER OF CYSTS DETECTED IN ANALYSIS
24 3 82	56	15	4				3.6				
26 3 82	56	15					3.4				
29 3 82	56	15					3.4				
31 3 82	56	15	5				4.2				
1 4 82	59	5	5	21900.		160.	4.0	5811.	500	327	2P
2 4 82	59	5		24300.	4400.	98.	4.1	1500.	500	278	5 2P
3 4 82	59	5		19000.	5000.	130.	3.7	1697.	500	828	0 2P
4 4 82	59	5		15100.	3200.	70.	4.0		500	164	0 2P
5 4 82	59	5		1040.	3550.	2.	3.7	198.	0	0	0 2P
6 4 82	59	5	6	310.	1070.	0.	3.9	74.	0	0	0 2P
7 4 82	62	15	6				3.4				
8 4 82	62	15					3.2				
10 4 82	62	15					2.9				
12 4 82	62	15					2.8				
14 4 82	62	15					2.7				
17 4 82	62	15					3.5				
19 4 82	62	15					4.0				
21 4 82	62	15					5.0				
23 4 82	62	15					4.8				
26 4 82	62	15					4.9				
28 4 82	62	15					4.2				
30 4 82	62	15					5.1				
3 5 82	62	15					4.9				
5 5 82	62	15					5.7				
7 5 82	62	15					4.4				
10 5 82	62	15					4.3				
12 5 82	62	15					4.1				
16 5 82	62	15	11				4.4				
17 5 82	65	15	12	5800.			5.0		50	66.7	2P
18 5 82	65	15		1010000.	290.		5.2		50	53.2	0 2P
19 5 82	65	15		6400.	430.		5.4		50	14.5	0 2P
20 5 82	65	15		8500.	450.		5.3		50	42.6	2 2P
21 5 82	65	15		23300.	1170.		4.5		50	10.4	0 2P
22 5 82	65	15		68000.	5.	0.	4.4		50	7.1	0 2P
23 5 82	65	15		22200.	10.	0.	4.5		50	56.3	1 2P
24 5 82	65	15	13	28100.	14.	0.	4.4		50	0.6	1 2P
25 5 82	68	5	13	10300.	49.	0.	4.4		50	21.4	3 2P
26 5 82	68	5		13200.	540.	0.	4.3		50	95.4	2 2P
27 5 82	68	5		2900.	730.	1.	4.4	1150.	50	21.1	0 2P
28 5 82	68	5		9100.	2320.	2.	4.4	935.	50	17.9	0 2P
29 5 82	68	5	13	490.	48.	1.	4.4	48.	12.5	61	2 2P

Table A-2. Results of experiments for slow sand Filter No. 2, v = 0.12 m/h (page 7 of 10).

DATE	RYN NO.	TEMP (°C)	AGE OF SCHMUTZ-DECKE (WEEKS)	STANDARD PLATE COUNT (NO./ML)	TOTAL COLIFORM CONCENTRATION (COLIF./100ML)	FECAL COLIFORM CONCENTRATION (COLIF./100ML)	TURBIDITY (NTU)	PARTICLE COUNT CONCENTRATION (NO./10ML)	GIARDIA CYST CONCENTRATION (CYSTS/L)	INFLUENT GIARDIA CYST CONCENTRATION (CYSTS/L)	EFFLUENT GIARDIA CYST CONCENTRATION (CYSTS/L)	NUMBER OF CYSTS OF CYSTS DETECTED IN ANALYSIS	
BY	MO	YR		INFLUENT	EFFLUENT	INFLUENT	EFFLUENT	INFLUENT	EFFLUENT	ADDED	DETECTED	(L)	(NO.)
1	6	82	71	15			3.9	2.0					
2	6	82	71	15			3.7	1.9	1462.	4402.			
3	6	82	71	15			3.7	2.0					
4	6	82	71	15			3.8	2.1					
5	6	82	74	15	4200.	330.	4.4	4.0			8.7	-	-
6	6	82	74	15	5100.		3.7	4.1	426.	276.	50	79	0
7	6	82	74	15	3020.	490.	3.8	3.9			50	79	0
8	6	82	74	15	2980.	1100.	3.8	3.6			50	31.1	0
9	6	82	74	15	12100.	1800.	3.7	3.4	422.	78.	50	71	0
10	6	82	74	15	7600.	1600.	3.8	3.4			50	16.6	0
11	6	82	74	15	140.	0.	5.8	3.4			50	20.4	0
12	6	82	74	15			3.6	2.7			50	-	0
13	6	82	74	15	3450.	260.	3.5	2.8					
14	6	82	74	15	5800.	262.	3.5	2.8			50	18.0	-
15	6	82	74	15	2670.	490.	3.5	3.0	497.	85.	50	26.9	0
16	6	82	74	15	2265.	720.	3.5	3.1			50	15.1	0
17	6	82	74	15	2725.	130.	3.3	3.2			50	19.9	0
18	6	82	74	15	2520.	181.	3.3	3.1			50	16.7	0
19	6	82	74	15	3910.	391.	3.4	3.0			50	16.7	0
20	6	82	74	15	280.		3.4	2.8			0	62	0
21	6	82	77	15	380.	145.	3.7	2.8					
22	6	82	77	15	1070.	155.							
23	6	82	77	15	800.	59.	4.1	2.9					
24	7	82	77	15	640.	141.							
25	7	82	77	15	1300.	452.	3.8	2.7					
26	7	82	80	5	1785.	100.	4.1	3.2			50	34.3	MP
27	7	82	80	5	2655.	67.	4.1	3.0			50	56.0	MP
28	7	82	80	5	2800.	71.	4.4	3.3			50	29.1	MP
29	7	82	80	5	2785.	31.	4.4	3.4			50	26.7	MP
30	7	82	80	5	2875.	440.	4.4	3.4			50	28.1	MP
31	7	82	80	5	1790.	10.	4.2	3.3			50	-	MP
32	7	82	80	15			3.3	2.7					
33	7	82	80	15			3.4	2.4					
34	7	82	80	15			3.5	2.4					
35	7	82	80	5	800.	23.	3.5	2.2			50	16.6	MP
36	7	82	80	5	845.	175.	3.5	2.2			50	30.0	MP
37	7	82	80	5	1390.	370.	3.5	2.3			50	15.7	MP
38	7	82	80	5	2045.	20.	3.5	2.5			50	13.6	MP
39	7	82	80	5	1290.	365.	3.5	2.5			50	58.2	MP
40	7	82	80	5			3.7	2.6			50	45.6	MP

Table A-2. Results of experiments for slow sand Filter No. 2,  $v = 0.12$  m/h (page 8 of 10).

DATE	RUN NO.	TEMP (°C)	AGE OF DECKE (WEEKS)	STANDARD		TOTAL COLIFORM CONCENTRATION (COLIF./100ML)	FECAL COLIFORM CONCENTRATION (COLIF./100ML)	TURBIDITY (NTU)	PARTICLE COUNT CONCENTRATION (NO./10ML)	INFLUENT GIARDIA CYST CONCENTRATION (CYSTS/L)	EFFLUENT GIARDIA CYST CONCENTRATION (CYSTS/L)	EFFLUENT VOLUME SAMPLED (L)	NUMBER OF CYSTS DETECTED IN ANALYSIS	GIARDIA ANALYSIS METHOD
				FLATE COUNT CONCENTRATION (NO./ML)	INFLUENT EFFLUENT CONCENTRATION									
25	7 82	83	15	3	20000.	160.	4400.	4.	3.6	2.7	123	-	-	MP
26	7 82	83	15		4400.	40.	600.	11.	4.0	2.5	173	72	0	MP
27	7 82	83	15		1600.	126.	700.	6.	4.1	2.5	0	71	0	MP
28	7 82	83	15		4500.	0.	4300.	7.	4.1	2.4	256	-	-	MP
29	7 82	83	15	4	4400.	190.	650.	6.	3.9	2.4	183	68	0	MP
30	7 82	83	15	4	66000.	780.	74000.	143.	5.0	2.4	0	66	0	MP
1	8 82	86	15	4	66000.	1100.	71000.	90.	5.0	2.7	167	-	-	MP
2	8 82	86	15		15800.	150.	290000.	10.	5.0	2.5	220	57	0	MP
3	8 82	86	15		10700.	110.	210000.	4.	4.8	2.5	160	69	0	MP
4	8 82	86	15	5	4500.	246.	22000.	1.	5.2	2.6	258	61	0	MP
5	8 82	86	15	5	6300.	40.	13800.	2.	4.8	2.7	300	187	0	MP
6	8 82	89	15		17100.	17850.	18000.	6.	5.6	2.7				
7	8 82	89	15		39900.	114.	17000.	1.	5.6	2.7				
8	8 82	89	15	6	7100.	86.		1.	5.5	2.7				
9	8 82	91	15	6	5800.	320.	2050.	0.	5.1	2.4				
10	8 82	91	15		550.	113.	75.	0.	5.0	2.7				
11	8 82	91	15	7					5.1	2.8				
12	8 82	91	15	7					5.1	2.9				
13	8 82	96	15						5.2	2.7				
14	8 82	96	15						5.5	3.3				
15	8 82	96	15						6.4	3.6				
16	8 82	96	15						6.5	3.8				
17	8 82	96	15						6.7	3.6				
18	8 82	96	15						6.7	3.6				
19	8 82	96	15						7.2	4.0				
20	8 82	96	15						7.5	4.1				
21	8 82	96	15						7.6	4.1				
22	8 82	96	15	12										

Table A-2. Results of experiments for slow sand Filter No. 2, v = 0.12 m/h (page 9 of 10).

DATE DY MO YR	RUN NO.	TEMP (°C)	AGE OF SAND BECKE (WEEKS)	STANDARD		TOTAL COLIFORM CONCENTRATION (COLIF./100ML)	FECAL COLIFORM CONCENTRATION (COLIF./100ML)	TURBIDITY (NTU)	PARTICLE COUNT CONCENTRATION (NO./10ML)	INFLUENT		EFFLUENT VOLUME SAMPLED (L)	NUMBER OF CYSTS DETECTED IN EFFLUENT	GIARDIA ANALYSIS METHOD
				FLATE COUNT CONCENTRATION (NO./ML)	INFLUENT EFFLUENT					GIARDIA CYST CONCENTRATION (CYSTS/L)	ADDED DETECTED			
28 9 82	99 15		12	2250.	21000.			9.0	4.3					
29 9 82	99 15			3500.	24000.									
30 9 82	99 15			2700.	32000.	275.		7.9	4.7					
1 10 82	99 15			3350.	7000.	290.		6.9	4.7					
2 10 82	99 15			1100.	380.	4400.	107.	7.2	4.9					
3 10 82	99 15			2000.	80.	6000.	170.							
4 10 82	99 15			2675.	1060.	21000.	85.	7.8	4.6					
5 10 82	99 15			2800.	26500.	110.								
6 10 82	99 15			2005.	43.	20000.	41.	7.4	4.5					
7 10 82	99 15			2340.	143.	500.	33.	7.1	4.6					
8 10 82	99 15			3600.	143.	145.	9.							
9 10 82	99 15			430.	430.	6.								
10 10 82	99 15							7.1	4.7					
11 10 82	99 15			10250.	47500.			7.3	4.5					
12 10 82	99 15			1700.	255.	1150.	22.							
13 10 82	99 15			2800.	12500.			8.0	4.6					
14 10 82	99 15													
15 10 82	99 15			2350.	6400.	700.	8.							
16 10 82	99 15													
18 10 82	99 15		15					7.5	4.8					
20 10 82	102 15		16	19400.	600.			7.8	4.8	1000	720			MP
21 10 82	102 15			29750.	1245.	13000.	4.	7.8	5.4	1173	986	51	0	MP
22 10 82	102 15			670.	830.	3.	17.	7.6	5.6	0	0	87	0	MP
23 10 82	102 15			600.	580.	4.	5.	7.6	5.4	0	0	70	0	MP
24 10 82	102 15			650.	320.	1.	3.	7.6	5.6	0	0	66	0	MP
25 10 82	102 15		16	420.	305.	2.	2.	7.7	5.5	0	0	68	0	MP
26 10 82	105 15		16	4400.	23500.	1.	1.	8.4	5.7	5000	2060			MP
27 10 82	105 15			7750.	361.	22500.	30.	8.0	5.5	5150	3350	60	0	MP
28 10 82	105 15			995.	260.	1.	18.	8.1	5.6	0	0	95	0	MP
29 10 82	105 15			1400.	130.	1.	4.	8.2	5.7	0	0	121	0	MP
30 10 82	105 15			450.	80.	3.	1.	8.3	5.9	0	0	79	0	MP
31 10 82	105 15			955.	305.	2.	0.	8.0	5.9	0	0	80	0	MP
1 11 82	105 15			13.	6.	2.	0.							
2 11 82	105 15		17	800.	80.	3.	0.							
3 11 82	108 15		0	16500.	870.	20000.	0.	7.8	6.1	1505	784			MP
4 11 82	108 15			27000.	1010.	24000.	195.	8.1	7.3	1500	668	71	0	MP
5 11 82	108 15			315.	560.	3.	235.	8.1	7.8	0	0	113	0	MP
6 11 82	108 15			126.	180.	0.	22.	8.9	8.1	0	0	63	0	MP
7 11 82	108 15			144.	127.	0.	13.	8.9	8.1	0	0	107	0	MP
8 11 82	108 15			111.	84.	1.	6.	9.1	8.3	0	0			
9 11 82	108 15		1	327.	144.	1.	7.							

Table A-2. Results of experiments for slow sand Filter No. 2, v = 0.12 m/h (page 10 of 10).

DATE	RUN NO.	TEMP (°C)	AGE OF DECKE (WEEKS)	STANDARD PLATE COUNT		TOTAL COLIFORM CONCENTRATION (COLIF./100ML)	FECAL COLIFORM CONCENTRATION (COLIF./100ML)	TURBIDITY (NTU)	PARTICLE COUNT CONCENTRATION (NO./10ML)	INFLUENT GIARDIA CYST CONCENTRATION (CYSTS/L)		EFFLUENT VOLUME SAMPLED (L)	NUMBER OF CYSTS DETECTED IN ANALYSIS
				INFLUENT (NO./ML)	EFFLUENT (NO./ML)					ADDED	DETECTED		
12 11 82	111	15	0	37500.	20500.			10.9	15.5	1982	1250	-	MP
13 11 82	111	15		29100.	15500.	1118.		10.2	12.9	1923	1863	67	0
14 11 82	111	15		210.	5700.	6.	570.	9.9	11.1	0	-	96	0
15 11 82	111	15		10.	23.	1.	57.	9.6	9.7	0	-	192	0
16 11 82	111	15		82.	710.	1.	34.	9.7	9.7	0	-	99	0
17 11 82	111	15		110.	182.	0.	12.	10.2	8.7	0	-	-	0
18 11 82	111	15	1	3010.	1455.	0.	11.	9.5	8.2	0	-	-	0
19 11 82	111	15	2	1120.	810.	0.	4.	10.4	7.8	0	-	-	0
22 11 82	114	15	2					9.7	7.7				
24 11 82	114	15						10.0	7.7				
26 11 82	114	15						9.6	7.6				
29 11 82	114	15						9.8	7.6				
1 12 82	114	15						10.1	7.6				
3 12 82	114	15	3					10.4	7.6				
18 1 83	119	15	10	119500.	39000.			10.1	7.5	2000	2100	-	MP
19 1 83	119	15		80000.	42000.	670.		9.9	7.9	2000	1458	193	0
20 1 83	119	15		172000.	52500.	895.		9.9	7.9	2000	1282	139	0
21 1 83	119	15		160000.	39000.	870.		10.0	7.6	2000	920	154	0
22 1 83	119	15		19500.	13350.	930.		9.6	7.3	0	-	166	0
23 1 83	119	15		3700.	800.	180.		9.2	7.4	0	-	173	0
24 1 83	119	15	11	960.	1000.	72.		9.7	7.4	0	-	-	0
26 1 83	119	15	11	290.	720.	14.							

Table A-3. Results of Experiments for Slow Sand Filter No. 3, v = 0.40 m/h (page 1 of 9)

DATE	RUN NO.	TEMP (°C)	AGE OF DECKE (WEEKS)	STANDARD		TOTAL COLIFORM CONCENTRATION (COLIF./100ML)	FECAL COLIFORM CONCENTRATION (COLIF./100ML)	TURBIDITY (NTU)	PARTICLE COUNT CONCENTRATION (NO./10ML)	INFLUENT GIARDIA CYST CONCENTRATION (CYSTS/L)	EFFLUENT VOLUME SAMPLED (L)	NUMBER OF CYSTS DETECTED IN ANALYSIS
				PLATE COUNT CONCENTRATION (NO./ML)	INFLUENT EFFLUENT INFLUENT EFFLUENT							
27	8	9	15	0				4.4			4.4	
28	8	8	15					4.4			4.4	
29	8	8	15					3.9			3.7	
30	8	8	15					4.0			3.7	
1	9	8	15					4.1			3.7	
2	9	8	15	1				4.1			4.0	
3	9	8	15	1		92000.	19000.	6.4			4.6	
4	9	8	15	1		75000.	1700.	4.2			5.2	
5	9	8	15	1			1400.	4.5			4.5	
6	9	8	15					4.4			4.2	
7	9	8	15					4.7			5.0	
8	9	8	15					4.5			5.3	
9	9	8	15					4.5			5.5	
10	9	8	15					4.6			5.6	
11	9	8	15					4.6			5.4	
12	9	8	15					5.0			4.8	
13	9	8	15					4.9			4.7	
14	9	8	15					5.8			4.7	
17	9	8	15					6.0			5.3	
18	9	8	15					5.8			5.5	
19	9	8	15					5.9			5.5	
20	9	8	15					5.5			5.4	
21	9	8	15	4				5.4			5.1	
22	9	8	15	4				7.2			4.7	
23	9	8	15					5.8			5.0	
24	9	8	15	4				5.6			3.2	
25	9	8	15	4		28900.		5.7			5.3	
26	9	8	15	4		100000.	0.	5.8			5.3	
27	9	8	15	5				5.9			5.7	
28	9	8	15					6.2			5.2	
29	9	8	15					7.0			5.5	
30	9	8	15					7.1			5.5	
1	10	8	15					6.4			5.6	
2	10	8	15	5				6.5			5.9	
3	10	8	15	5		80.		6.5			5.3	
4	10	8	15	5		390.		6.8			6.3	
5	10	8	15	5		290.	195.	6.6			6.1	
6	10	8	15	5		70.	121.	6.8			6.1	
7	10	8	15	5	6			7.0			6.2	

Table A-3. Results of Experiments for Slow Sand Filter No. 3, v = 0.40 m/h (page 2 of 9)

DATE	RUN NO.	TEMP (°C)	AGE OF DECKE (WEEKS)	STANDARD PLATE COUNT (NO./ML)	TOTAL COLIFORM CONCENTRATION (COLIF./100ML)	FECAL COLIFORM CONCENTRATION (COLIF./100ML)	TURBIDITY (NTU)	PARTICLE COUNT CONCENTRATION (NO./10ML)	INFLUENT GIARDIA CYST CONCENTRATION (CYSTS/L)	INFLUENT GIARDIA CYST CONCENTRATION (CYSTS/L)	NUMBER OF CYSTS OF CYSTS DETECTED IN ANALYSIS	EFFLUENT VOLUME SAMPLED (L)	EFFLUENT ANALYSIS METHOD
10 10 81	28	15					6.3				5.2		
11 10 81	28	15					6.5				5.3		
12 10 81	28	15					6.9				5.4		
13 10 81	28	15					6.5				5.5		
14 10 81	28	15					6.7				5.6		
15 10 81	28	15					6.4				5.6		
16 10 81	28	15					6.8				5.8		
17 10 81	28	15					6.8				5.8		
18 10 81	28	15					6.7				5.6		
19 10 81	28	15					6.9				5.6		
20 10 81	28	15					7.0				5.5		
21 10 81	28	15					6.8				5.4		
22 10 81	28	15					7.0				5.4		
23 10 81	28	15					6.8				5.6		
24 10 81	28	15					6.5				5.7		
25 10 81	28	15					6.6				6.1		
26 10 81	28	15					6.6				5.9		
27 10 81	28	15					6.7				6.1		
28 10 81	28	15					6.4				6.1		
29 10 81	28	15	9				6.5				5.9		
30 10 81	31	5	9		22300.		6.5				5.5		
31 10 81	31	5			24200.		6.6				5.5		
1 11 81	31	5			28000.		6.4				6.1		
2 11 81	31	5			32300.		6.1				6.1		
3 11 81	31	5			39000.		6.2				6.1		
4 11 81	31	5	10		4000.		6.2				5.9		
6 11 81	34	15	0				6.2				5.7		
7 11 81	34	15			480.		6.3				5.1		
8 11 81	34	15			280.		6.3				6.0		
9 11 81	34	15			1900.		6.5				5.1		
10 11 81	34	15			40000.		6.3				5.1		
11 11 81	34	15			10000.		6.7				4.6		
12 11 81	34	15	1				6.7				4.8		
13 11 81	37	15	1				6.7				4.9		
14 11 81	37	15					6.4				4.0		
15 11 81	37	15					6.5				4.9		
16 11 81	37	15					6.7				5.5		
17 11 81	37	15					6.4				5.4		
18 11 81	37	15	2				6.5				5.3		

Table A-3. Results of Experiments for Slow Sand Filter No. 3, v = 0.40 m/h (page 3 of 9)

DATE	RUN NO.	TEMP (°C)	SQUAMITZ- DECKE	AGE OF DECKE (WEEKS)	STANDARD		TURBIDITY (NTU)	FECAL COLIFORM CONCENTRATION (COLIF./100ML)	TOTAL COLIFORM CONCENTRATION (COLIF./100ML)	PARTICLE COUNT CONCENTRATION (NO./10ML)	INFLUENT GIARDIA CYST CONCENTRATION (CYSTS/L)	EFFLUENT VOLUME SAMPLED (L)	NUMBER OF CYSTS DETECTED IN ANALYSIS
					PLATE COUNT CONCENTRATION (NO./ML)	INFLUENT EFFLUENT INFLUENT EFFLUENT INFLUENT EFFLUENT ADDED DETECTED							
19 11 81	40	15		2			6.2					5.1	
20 11 81	40	15					6.9					4.8	
21 11 81	40	15					6.3					4.4	
22 11 81	40	15					5.9					4.5	
23 11 81	40	15					6.3					4.2	
24 11 81	40	15					6.6					5.1	
25 11 81	40	15					6.5					4.9	
29 11 81	40	15					6.3					5.4	
30 11 81	40	15					6.4					4.7	
1 12 81	40	15					6.6					5.3	
2 12 81	40	15					7.1					4.7	
3 12 81	40	15					7.2					4.8	
4 12 81	40	15					6.8					4.7	
5 12 81	40	15					7.0					4.6	
6 12 81	40	15					7.0					5.0	
7 12 81	40	15					7.2					4.8	
8 12 81	40	15					6.7					4.5	
9 12 81	40	15					7.1					4.8	
10 12 81	40	15		5			7.3					5.0	
11 12 81	43	15		5			8.6					6.2	
12 12 81	43	15					8.8					6.6	
13 12 81	43	15					8.6					7.0	
14 12 81	43	15		6			8.9					7.7	
15 12 81	46	15		6			8.7					7.3	
16 12 81	46	15					8.8					6.8	
17 12 81	46	15					8.8					5.8	
18 12 81	46	15					9.1					6.8	
20 12 81	46	15					8.9					1.2	
22 12 81	46	15					8.7					2.0	
23 12 81	46	15					9.5					5.0	
27 12 81	46	15					8.9					4.8	
31 12 81	46	15					8.9					4.8	
4 1 82	46	15					8.8					4.2	
8 1 82	46	15					7.9					3.9	
10 1 82	46	15					8.0					4.4	
15 1 82	46	15					8.2					4.0	
18 1 82	46	15					8.1					4.4	
22 1 82	46	15					8.7					4.8	
25 1 82	46	15					9.2					4.9	
28 1 82	46	15					10.5					6.7	



Table A-3. Results of Experiments for Slow Sand Filter No. 3, v = 0.40 m/h (page 4 of 9)

DATE	RM NO.	TEMP (°C)	AGE OF DECKE (WEEKS)	STAINING PLATE COUNT CONCENTRATION (NO./ML)	TOTAL COLIFORM CONCENTRATION (COLIF./100ML)	FECAL COLIFORM CONCENTRATION (COLIF./100ML)	TURBIDITY (NTU)	PARTICLE COUNT CONCENTRATION (NO./10ML)	GIARDIA CYST CONCENTRATION (CYSTS/L)	EFFLUENT VOLUME SAMPLED (L)	NUMBER OF CYSTS DETECTED IN ANALYSIS
DI	MO	YR		INFLUENT	INFLUENT	INFLUENT	INFLUENT	INFLUENT	ADDED	DETECTED	
30	1	82	46	15			11.0	6.2			
2	2	82	46	15			11.0	4.9			
3	2	82	46	15	6200.						
4	2	82	46	15	9400.						
5	2	82	46	15	30000.		11.0	4.9			
6	2	82	46	15	6000.		9.2	5.0			
7	2	82	46	15	4100.						
8	2	82	46	15	6800.		8.5	5.1			
9	2	82	46	15	900.						
10	2	82	46	15	4400.						
11	2	82	46	15	2400.						
12	2	82	46	15	3200.		6.8	4.9			
13	2	82	46	15	1800.						
14	2	82	46	15	3200.		6.3	4.8			
15	2	82	46	15	200.						
16	2	82	46	15	7200.						
20	2	82	46	15			6.0	4.0			
26	2	82	49	5	360.	30000.	6.2	4.2			
27	2	82	49	5	300.	700.	4.0	5.3	500	413	-
28	2	82	49	5	260.	200.	4.7	4.1	151.	180	28
1	3	82	49	5	350.	1.	4.8	4.9	116.	500	24
2	3	82	49	5			5.0	4.6	41.	500	176
3	3	82	49	5	960.		4.7	4.4	78.	102	251
4	3	82	52	15			5.5	4.2	64.	0	67
5	3	82	52	15			3.8	4.1			
9	3	82	52	15	1700.	35000.	3.8	3.9			
10	3	82	52	15			4.5	3.2			
11	3	82	52	15							
12	3	82	52	15							
13	3	82	52	15	176.	500.	3.9	4.0			
14	3	82	52	15	300.	1240.					
15	3	82	52	15	157.	160.	4.1	3.2			
16	3	82	52	15	350.	160.	4.2	3.1			
17	3	82	52	15	319.	360.					
18	3	82	55	15	7900.	6300.	4.5	2.9	500	1262	-
19	3	82	55	15	8500.	6100.	4.5	2.5	31.	500	665
20	3	82	55	15	17900.	4900.	4.6	2.5	40.	500	656
21	3	82	55	15	40000.	3900.	4.4	2.3	58.	500	1965
22	3	82	55	15	300.	0.	3.6	2.1	54.	0	77
23	3	82	55	15	460.	0.	4.2	2.2	329.	0	70

Table A-3. Results of Experiments for Slow Sand Filter No. 3, v = 0.40 m/h (page 5 of 9)

DATE	RUN NO.	TEMP (°C)	AGE OF SLOWLY-DECKE (WEEKS)	STANDARD PLATE COUNT CONCENTRATION (NO./HL)		TOTAL COLIFORM CONCENTRATION (COLLIF./100ML)		FECAL COLIFORM CONCENTRATION (COLLIF./100ML)		TURBIDITY (NTU)	PARTICLE COUNT CONCENTRATION (NO./10ML)	INFLUENT GIARDIA CYST CONCENTRATION (CYSTS/L)	EFFLUENT VOLUME SAMPLED (L)	NUMBER OF CYSTS DETECTED IN EFFLUENT	GIARDIA ANALYSIS METHOD	
				INFLUENT	EFFLUENT	INFLUENT	EFFLUENT	ADDED	DETECTED							
24	3 82	58	15	4					3.6	1.8						
26	3 82	58	15						3.4	1.6						
29	3 82	58	15						3.4	2.4						
31	3 82	58	15	5					4.2	2.8						
1	4 82	61	5	5	21900.			160.	4.0	3.2	5811.	500	327	-	ZP	
2	4 82	61	5		24300.	15100.		98.	4.1	3.8	1500.	500	278	61	23	ZP
3	4 82	61	5		19000.	12500.		130.	3.7	2.6	1697.	500	828	74	0	ZP
4	4 82	61	5		15100.	9100.		70.	4.0	3.8		500	164	68	2	ZP
5	4 82	61	5		10400.	7600.		2.	3.7	3.5	198.	0	0	84	1	ZP
6	4 82	61	5	6	310.	1350.		0.	3.2	2.8		0	-	79	0	ZP
7	4 82	64	15	6					3.4	2.6						
8	4 82	64	15						3.2	1.9						
10	4 82	64	15						2.9	1.4						
12	4 82	64	15						2.8	1.8						
14	4 82	64	15						2.7	1.6						
17	4 82	64	15						3.5	2.3						
19	4 82	64	15						4.0	2.7						
21	4 82	64	15						5.0	2.6						
23	4 82	64	15						4.8	2.5						
26	4 82	64	15						4.9	2.8						
28	4 82	64	15						4.2	2.8						
30	4 82	64	15						5.1	3.1						
3	5 82	64	15						4.9	2.7						
5	5 82	64	15						5.7	4.0						
7	5 82	64	15						4.4	3.5						
10	5 82	64	15						4.3	2.6						
12	5 82	64	15						4.1	2.5						
16	5 82	64	15	11					4.4	2.4						
17	5 82	67	15	2	5800.				5.0	3.2		50	66.7	-	-	ZP
18	5 82	67	15		1010000.	1200.			5.2	3.9		50	53.2	64	0	ZP
19	5 82	67	15		6400.	2150.			5.4	3.4		50	14.5	79	0	ZP
20	5 82	67	15		8500.	440.			5.3	3.9		50	42.6	149	0	ZP
21	5 82	67	15		23300.	780.		0.	4.5	3.5		50	10.4	131	0	ZP
22	5 82	67	15		68000.		5.	0.	4.4	3.5		50	7.1	167	0	ZP
23	5 82	67	15		22200.	5100.	10.	0.	4.5	3.4		50	56.3	216	1	ZP
24	5 82	67	15	3	28100.	21700.	14.	0.	4.4	3.5		50	0.6	292	6	ZP
25	5 82	70	5	3	10300.	1265.	49.	0.	4.4	3.3		50	21.4	245	2	ZP
26	5 82	70	5		13200.	1795.	26.	3.	4.3	3.4		50	95.4	184	3	ZP
27	5 82	70	5		2900.	3200.	52.	2.	4.4	3.4	1150.	553.	21.1	148	3	ZP
28	5 82	70	5		9100.	1440.	48.	8.	4.4	3.6	935.	440.	17.9	172	0	ZP
29	5 82	70	5	4		1200.		3.	4.4	3.6		12.5	-	213	0	ZP

Table A-3. Results of Experiments for Slow Sand Filter No. 3, v = 0.40 m/h (page 6 of 9)

DATE	RUN NO.	TEMP (°C)	AGE OF FILTER (WEEKS)	STANDARD PLATE COUNT (NO./ML)		TOTAL COLIFORM CONC. (COLIF./100ML)	FECAL COLIFORM CONC. (COLIF./100ML)	TURBIDITY (NTU)	PARTICLE COUNT (NO./10ML)	INFLUENT GIARDIA CYST CONCENTRATION (CYSTES/L)	EFFLUENT GIARDIA CYST CONCENTRATION (CYSTES/L)	NUMBER OF CYSTS OF CYSTS	ANALYSIS METHOD
				INFLUENT	EFFLUENT								
1 6 82	73	15	4	4200.	330.	3.9	3.1	1462.	50	8.7	-	0	ZF
2 6 82	73	15	0	1500.	490.	3.7	3.8	426.	50	0.8	241	0	ZF
3 6 82	73	15	4	3020.	18.	3.7	3.1	472.	50	0.9	218	0	ZF
4 6 82	73	15	4	2980.	1100.	3.8	3.0	137.	50	31.1	230	0	ZF
5 6 82	76	15	0	620.	1800.	3.7	3.5	422.	50	16.6	172	0	ZF
6 6 82	76	15	4	7600.	1600.	3.7	3.3	172.	50	20.4	141	0	ZF
7 6 82	76	15	0	390.	8.	3.8	3.1	172.	50	-	179	0	ZF
8 6 82	76	15	4	170.	26.	3.6	2.6	172.	50	-	179	0	ZF
9 6 82	76	15	0	990.	31.	3.5	2.6	172.	50	-	179	0	ZF
10 6 82	76	15	4	2670.	490.	3.5	2.6	172.	50	-	179	0	ZF
11 6 82	76	15	0	2265.	290.	3.5	2.8	172.	50	18.0	-	1	ZF
12 6 82	76	15	4	2725.	340.	3.5	2.9	172.	50	26.9	229	0	ZF
13 6 82	76	15	0	2520.	245.	3.5	2.9	172.	50	15.1	253	0	ZF
14 6 82	76	15	4	3910.	160.	3.3	2.8	172.	50	19.9	228	0	ZF
15 6 82	76	15	0	202.	3910.	3.4	2.6	172.	50	16.7	149	0	ZF
16 6 82	79	15	3	380.	145.	3.4	2.6	172.	0	-	199	0	ZF
17 6 82	79	15	3	1070.	155.	3.7	2.7	172.	0	-	199	0	ZF
18 6 82	79	15	0	800.	265.	4.1	2.8	172.	0	-	199	0	ZF
19 6 82	79	15	4	640.	275.	4.1	2.8	172.	0	-	199	0	ZF
20 6 82	79	15	0	1300.	110.	3.8	2.7	172.	0	-	199	0	ZF
21 6 82	79	15	4	1785.	100.	4.1	3.0	172.	0	-	199	0	ZF
22 6 82	82	5	0	2655.	67.	4.1	3.1	172.	0	-	199	0	ZF
23 6 82	82	5	0	2800.	71.	4.4	3.2	172.	0	-	199	0	ZF
24 6 82	82	5	0	2785.	1340.	4.4	3.4	172.	0	-	199	0	ZF
25 6 82	82	5	0	2875.	1000.	4.4	3.3	172.	0	-	199	0	ZF
26 6 82	82	5	0	1790.	930.	4.2	3.3	172.	0	-	199	0	ZF
27 6 82	82	15	0	800.	23.	3.3	2.4	172.	0	-	199	0	ZF
28 6 82	82	15	0	845.	18.	3.4	2.6	172.	0	-	199	0	ZF
29 6 82	82	15	0	1390.	270.	3.5	2.3	172.	0	-	199	0	ZF
30 6 82	82	15	0	2045.	515.	3.5	2.3	172.	0	-	199	0	ZF
31 6 82	82	15	0	1290.	730.	3.5	2.5	172.	0	-	199	0	ZF
32 6 82	82	15	0	1290.	730.	3.5	2.6	172.	0	-	199	0	ZF
33 6 82	82	15	0	1290.	730.	3.7	2.6	172.	0	-	199	0	ZF

Table A-3. Results of Experiments for Slow Sand Filter No. 3, v = 0.40 m/h (page 7 of 9)

DATE	RUN NO.	TEMP (°C)	AGE OF DECKE (WEEKS)	STANDARD PLATE COUNT CONCENTRATION (NO./ML)	TOTAL COLIFORM CONCENTRATION (COLIF./100ML)	FECAL COLIFORM CONCENTRATION (COLIF./100ML)	TURBIDITY (NTU)	PARTICLE COUNT CONCENTRATION (NO./10ML)	INFLUENT GIARDIA CYST CONCENTRATION (CYSTS/L)	INFLUENT GIARDIA CYST CONCENTRATION (CYSTS/L)	EFFLUENT VOLUME SAMPLED (L)	NUMBER OF CYSTS DETECTED IN ANALYSIS	GIARDIA ANALYSIS METHOD
25	7 82	85	15	3			3.6	2.8					
26	7 82	85	15		20000.	460.	4.0	2.4					
27	7 82	85	15		4400.	220.							
28	7 82	85	15		1600.	630.	4.1	2.3					
29	7 82	85	15		4500.	550.	4.1	2.3					
30	7 82	85	15	4	4400.	130.	3.9	2.3					
1	8 82	88	15	4	66000.	74000.	5.0	2.3	1000	123			MP
2	8 82	88	15		66000.	71000.	5.0	2.6	1000	173			MP
3	8 82	88	15		3600.	1200.	5.0	2.8	0		232	80	MP
4	8 82	88	15		15800.	290000.	5.0	2.7	1000	256			MP
5	8 82	88	15		10700.	260.	4.8	2.8	1000	181		40	MP
6	8 82	88	15	5	230.	0.	5.2	2.2	0		220	100	MP
8	8 82	91	15	5	4500.	22000.	4.8	2.6	1000	167			MP
9	8 82	91	15		6300.	13000.	5.0	3.0	1000	220		191	MP
10	8 82	91	15		17100.	13800.	4.8	3.1	1000	160		233	MP
11	8 82	91	15		17850.	18000.	5.6	3.0	1000	258		223	MP
12	8 82	91	15		39900.	490.	5.6	3.2	1000	300		196	MP
13	8 82	91	15	6	256.	86.	5.5	3.2					
16	8 82	94	15	6	7100.	2050.	5.1	2.9					
17	8 82	94	15		5800.	1600.	5.0	3.2					
18	8 82	94	15		550.	83.	5.1	3.3					
20	8 82	94	15	7		75.	5.1	3.4					
24	8 82	97	15	7			5.2	3.4					
27	8 82	97	15				5.5	4.5					
31	8 82	97	15				6.4	4.3					
3	9 82	97	15				6.5	4.3					
7	9 82	97	15				6.7	4.5					
10	9 82	97	15				6.7	4.6					
13	9 82	97	15				6.9	4.5					
16	9 82	97	15				7.2	4.7					
18	9 82	97	15				7.5	4.6					
21	9 82	97	15				7.6	4.7					
24	9 82	97	15	12									

Table A-3. Results of Experiments for Slow Sand Filter No. 3, v = 0.40 m/h (page 8 of 9)

DATE	RUN NO.	TEMP (°C)	AGE OF DECKE (WEEKS)	STANDARD PLATE COUNT (NO./ML)		TOTAL COLIFORM CONCENTRATION (COLIF./100ML)	FECAL COLIFORM CONCENTRATION (COLIF./100ML)	TURBIDITY (NTU)	PARTICLE COUNT CONCENTRATION (NO./10ML)	INFLUENT GIARDIA CYST CONCENTRATION (CYSTS/L)	EFFLUENT GIARDIA CYST CONCENTRATION (CYSTS/L)	EFFLUENT VOLUME SAMPLED (L)	NUMBER OF CYSTS DETECTED IN ANALYSIS	ANALYSIS METHOD
				INFLUENT	EFFLUENT									
28 9 82	100	15	12	2250.	2500.	21000.	114.	9.0	4.2					
29 9 82	100	15		3500.	2500.	24000.	114.							
30 9 82	100	15		2700.	580.	32000.	185.	7.9	4.6					
1 10 82	100	15		3350.	340.	7000.	140.	6.9	4.4					
2 10 82	100	15		1100.	570.	4400.	120.	7.2	4.5					
3 10 82	100	15		2000.	200.	6000.	80.							
4 10 82	100	15		2675.	380.	21000.	63.	7.8	4.1					
5 10 82	100	15		2800.	230.	26500.	125.							
6 10 82	100	15		2005.	90.	20000.	61.	7.4	3.9					
7 10 82	100	15		2340.	185.	500.	31.	7.1	3.9					
8 10 82	100	15		3600.	219.	145.	20.							
9 10 82	100	15			136.	7.								
10 10 82	100	15												
11 10 82	100	15		10250.		47500.		7.1	3.8					
12 10 82	100	15		1700.	80.	1150.	37.	7.3	3.8					
13 10 82	100	15		2800.		12500.								
14 10 82	100	15						8.0	3.8					
15 10 82	100	15		2350.	85.	700.	20.							
16 10 82	100	15		40.		10.								
18 10 82	100	15	15											
20 10 82	103	15	16	19400.		600.		7.5	4.0	1000	720			MP
21 10 82	103	15		29750.	1245.	13000.	5.	7.8	4.6	1173	986	183	0	MP
22 10 82	103	15		670.	1460.	3.	28.	7.6	4.8	0		315	0	MP
23 10 82	103	15		600.	890.	4.	12.	7.6	4.4	0		216	0	MP
24 10 82	103	15		650.	520.	1.	6.	7.6	4.7	0		203	0	MP
25 10 82	103	15	16	420.	340.	2.	3.	7.7	4.8	0		217	0	MP
26 10 82	106	15	16	4400.		23500.	2.	8.4	4.9	5000	2060			MP
27 10 82	106	15		7750.	105.	22500.	101.	8.0	4.8	5150	3350	193	0	MP
28 10 82	106	15		995.	235.	1.	76.	8.1	4.9	0		309	0	MP
29 10 82	106	15		1400.	165.	1.	7.	8.2	4.9	0		401	0	MP
30 10 82	106	15		450.	101.	3.	3.	8.3	4.9	0		268	0	MP
31 10 82	106	15		955.	142.	2.	4.	8.0	5.0	0		269	0	MP
1 11 82	106	15		13.	119.	2.	1.							
2 11 82	106	15	17	800.	43.	3.	1.	7.8	5.0					
3 11 82	109	15	0	16500.	273.	20000.	2.	8.1	8.0	1505	784			MP
4 11 82	109	15		27000.	1940.	24000.	680.	8.1	7.6	1500	668	240	0	MP
5 11 82	109	15		315.	1370.	3.	560.	8.9	7.9	0		382	0	MP
6 11 82	109	15		126.	420.	0.	152.	8.9	7.2	0		215	0	MP
7 11 82	109	15		144.	27.	0.	79.	9.1	7.1	0		362	0	MP
8 11 82	109	15			111.	101.	51.							
9 11 82	109	15	1	327.	155.	1.	30.							

Table A-3. Results of Experiments for Slow Sand Filter No. 3, v = 0.40 m/h (page 9 of 9)

DATE	RUN NO.	TEMP (°C)	AGE OF FILTER (WEEKS)	STANDARD PLATE COUNT (NO./ML)		TOTAL COLIFORM CONCENTRATION (COLIF./100ML)	FECAL COLIFORM CONCENTRATION (COLIF./100ML)	TURBIDITY (NTU)	PARTICLE COUNT CONCENTRATION (NO./10ML)	INFLUENT GIARDIA CYST CONCENTRATION (CYSTS/L)		EFFECTIVE VOLUME SAMPLED (L)	NUMBER OF CYSTS DETECTED IN ANALYSIS	EFFECTIVE METHOD
				INFLUENT	EFFLUENT					ADDED	DETECTED			
12 11 82	112	15	0	37500.	20500.	1350.	10.9	9.7	1982	1250	-	-	MP	
13 11 82	112	15		29100.	15500.	680.	10.2	10.0	1923	1863	193	0	MP	
14 11 82	112	15		210.	6.	680.	9.9	9.5	0	-	314	0	MP	
15 11 82	112	15		10.	1.	175.	9.6	8.8	0	-	189	0	MP	
16 11 82	112	15		82.	1.	105.	9.7	8.2	0	-	324	0	MP	
17 11 82	112	15		110.	0.	65.	10.2	7.8	0	-	-	-	MP	
18 11 82	112	15	1	3010.	0.	28.	9.5	7.2	0	-	-	-	MP	
19 11 82	112	15	2	1120.	0.	12.	10.4	6.6	0	-	-	-	MP	
22 11 82	115	15					9.7	5.9						
24 11 82	115	15					10.0	6.0						
26 11 82	115	15					9.6	6.1						
29 11 82	115	15					9.8	6.3						
1 12 82	115	15					10.1	6.3						
3 12 82	115	15	3				10.4	6.3						
7 12 82	117	15	4		29500.		10.7	4.8	3692	2433	-	-	MP	
8 12 82	117	15		11800.	100.	0.	10.6	4.6	3692	4507	102	0	MP	
9 12 82	117	15		5600.	600.	0.	9.5	5.3	0	-	194	0	MP	
10 12 82	117	15		20300.	210.	2.	9.5	5.5	0	-	112	0	MP	
11 12 82	117	15		13700.	112.	0.	9.8	5.4	0	-	157	0	MP	
12 12 82	117	15		10800.	247.	1.	9.8	5.7	0	-	-	-	MP	
13 12 82	117	15	5	2550.	61.	0.	9.8	5.7	0	-	-	-	MP	
14 12 82	117	15		530.	267.	0.								

## APPENDIX B

### Results of Phase II and Phase III Experiments for Slow Sand Filtration 2/1983 - 12/1983

The following six tables, Tables B-1, B-2, B-3, B-4, B-5, and B-6 contain all of the Phase II and III experimental results obtained from six laboratory scale slow sand filters, operated continuously at a hydraulic loading rate of 0.12 m/hr over the period February 1983 to December 1983. These tables contain the raw data collected for total coliform bacteria, standard plate count bacteria, and turbidity. The tables in this appendix can be cross-referenced by date with Figures I-4 through I-9, in Appendix I, which contain graphical histories of temperature, hydraulic loading rate, and headloss.

The test condition imposed on each filter is summarized as follows:

<u>Table</u>	<u>Filter No.</u>	<u>Test Variable</u>
B-1	1	Control
B-2	2	Depth of sand bed
B-3	3	Chlorine added
B-4	4	Nutrients added
B-5	5	Large sand, 5°C
B-6	6	5°C

Table B-1. Phase II slow sand filter data for Filter No. 1, the control filter.

DATE	DAYS OF CONTINUOUS OPERATION	AGE OF SCHLUTZDECKE	INFLUENT TURBIDITY	EFFLUENT TURBIDITY	INFLUENT COLIFORM	EFFLUENT COLIFORM	INFLUENT STD PLATE COUNT	EFFLUENT STD PLATE COUNT
MM BY YR	(DAYS)	(DAYS)	(NTU)	(NTU)	(NO/100ML)	(NO/100ML)	(NO/ML)	(NO/ML)
2 9 83	1	1	9.1	6.6				
2 10 83	2	2	9.1	8.0	2.0		240	3345
2 11 83	3	3	8.9	8.5	51000.0	0.0	1310	65000
2 12 83	4	4	9.0	8.4	7100.0	52000.0	755	125000
2 13 83	5	5	9.0	8.3	3400.0	5300.0	74	24200
2 14 83	6	6	8.7	8.1	4900.0	150.0	985	31100
2 15 83	7	7	8.8	8.2	5000.0	390.0	3620	18250
2 16 83	8	8	8.7	8.5	2250.0	570.0	4000	12200
2 17 83	9	9	8.6	9.5				
2 20 83	12	12	8.6	8.5	20000.0		3850	
2 21 83	13	13	8.6	8.5	14667.0	13600.0	365	2700
2 22 83	14	14	8.5	8.1	21000.0	5750.0	630	2790
2 23 83	15	15	8.6	8.3	37500.0	9200.0	635	3150
2 24 83	16	16	8.3	8.1	20500.0	13100.0	9650	1337
2 25 83	17	17	8.4	7.9		4550.0		150
2 27 83	19	19	8.3	8.0	1460.0		1015	
2 28 83	20	20	8.2	7.9	990.0	140.0	395	2400
3 1 83	21	21	8.0	7.7	6700.0	39.5	125	1320
3 2 83	22	22	7.8	7.7	2200.0	1235.0	330	1120
3 3 83	23	23	8.2	7.7	640.0	120.0	131	630
3 4 83	24	24	8.0	7.7		47.0		116
3 6 83	26	26	8.1		125.0		600	
3 7 83	27	27	7.4	7.5	48.0	7.0	44	1500
3 8 83	28	28	7.6	7.3	126.0	3.0	3045	3155
3 9 83	29	29	7.5	7.2	42.5	2.5	135	1060
3 10 83	30	30	7.6	7.2	2000.0	1.5	330	1220
3 11 83	31	31	7.6	7.1		41.5		1970
3 14 83	34	34	7.8	7.1	2650.0		415	
3 15 83	35	35	7.8	7.1	20000.0	35.0	945	1265
3 16 83	36	36	7.4	7.2	22000.0	1205.0	975	1040
3 17 83	37	37	7.4	7.1		790.0		1500
3 20 83	40	40	7.2	7.0	66000.0		595	
3 21 83	41	41	7.0	6.9	76500.0	2250.0	830	1065
3 22 83	42	42	6.9	6.8	91500.0	2300.0	9950	1050
3 23 83	43	43	6.8	6.7	61000.0	2500.0	700	915
3 24 83	44	44	6.7	6.7	66500.0	750.0	775	685
3 25 83	45	45	6.7	6.3		900.0		1130
3 27 83	47	47	6.8	6.3	64000.0		850	
3 28 83	48	48	6.7	6.2	14000.0	1400.0	340	755
3 29 83	49	49	6.7	6.2		1150.0		600
4 5 83	56	56	7.3	6.2	3000.0		19200	
4 6 83	57	57	7.2	6.2	2200.0	4.0	1570	660
4 7 83	58	58	7.0	5.8	1100.0	5.0	1790	1075
4 8 83	59	59	7.0	5.8		12.0		590
4 11 83	62	62	6.8	6.0	3950.0		690	
4 12 83	63	63	6.8	6.0	3000.0	26.0	775	345
4 13 83	64	64	6.8	6.0	6700.0	59.0	285	415
4 14 83	65	65	6.7	5.9		38.0		410
4 16 83	67	1						
4 21 83	72	6	6.6	6.3				
4 22 83	73	7	6.4	5.9				
4 25 83	76	10	7.7	5.8	145000.0		1555	
4 26 83	77	11	6.9	5.8	125000.0	1500.0	1375	335
4 27 83	78	12	6.5	5.5	215000.0	900.0	2285	160
4 28 83	79	13	6.4	5.3		2100.0		435
5 3 83	84	18	6.7	5.0				
5 4 83	85	19	6.6	5.0				
5 15 83	96	30	6.3	4.0				
5 16 83	97	1	6.3	3.9	113000.0		1460	
5 17 83	98	2	6.3	4.1	70500.0	450.0	755	515
5 18 83	99	3	6.2	4.1	72500.0	330.0	840	390
5 19 83	100	4	6.2	4.1	70000.0	425.0	965	815
5 20 83	101	5	6.1	4.1		430.0		15
5 23 83	104	8	6.1	4.1	63000.0		1145	
5 24 83	105	9	6.0	4.1	69000.0	240.0	820	555
5 25 83	106	10	6.1	4.1	69000.0	180.0	390	980
5 26 83	107	11	6.1	4.0	56500.0	330.0	670	960
5 27 83	108	12	6.0	4.1		360.0		1265
5 30 83	111	15	6.1	4.2	64000.0		680	
5 31 83	112	16	6.1	4.2	52500.0	190.0	710	580

(CONTINUED)



Table B-1. (continued).

DATE MN DY YR	DAYS OF CONTINUOUS OPERATION (DAYS)	AGE OF SCHMUTZBOCKE (DAYS)	INFLUENT TURBIDITY (NTU)	EFFLUENT TURBIDITY (NTU)	INFLUENT COLIFORM (NO/100ML)	EFFLUENT COLIFORM (NO/100ML)	INFLUENT STD PLATE COUNT (NO/ML)	EFFLUENT STD PLATE COUNT (NO/ML)
6 1 83	113	17	6.2	4.2	35500.0	655.0	630	965
6 2 83	114	18	6.1	4.2		320.0		820
6 27 83	139	43	8.9	5.6	35000.0		515	
6 28 83	140	44	7.8	5.5	38000.0	180.0	660	895
6 29 83	141	45	7.4	5.4	49000.0	440.0	655	975
6 30 83	142	46	7.3	5.5	33000.0	710.0	420	760
7 1 83	143	47	7.3	5.6		610.0		740
7 4 83	146	50	7.0	5.8	930.0		224	
7 5 83	147	51	7.0	5.9	2300.0	30.0	155	580
7 6 83	148	52	7.0	6.0	3200.0	73.0	150	140
7 7 83	149	53	7.0	6.0	4250.0	82.0	515	750
7 8 83	150	54	7.0	6.1		88.0		405
7 11 83	153	57	7.1	6.1	35.0		3000	
7 12 83	154	58	7.1	6.1	66.0	.5	280	635
7 13 83	155	59	6.9	6.2	76.0	.5	190	33
7 14 83	156	60	6.8	6.2	74.0	.5	160	515
7 15 83	157	61	6.8	6.1	31.0	.5	490	650
7 18 83	160	64	6.8	6.2	340.0		320	
7 19 83	161	65	6.7	6.3	230.0	15.0	345	590
7 20 83	162	66	6.6	6.2	290.0	21.0	340	590
7 21 83	163	67	6.8	6.2	310.0	13.0	180	610
7 22 83	164	68	6.8	6.3	2100.0	41.0	130	475
7 23 83	165	69	7.0	6.2	2300.0	260.0		
7 24 83	166	70	7.0	6.2	2300.0	150.0	350	
7 25 83	167	71	7.0	6.2	2000.0	210.0	307	530
7 26 83	168	72	6.8	6.4	20500.0	170.0	325	460
7 27 83	169	73	6.8	6.6	12000.0	820.0	485	715
7 28 83	170	74	6.8	6.6	6600.0	650.0	205	450
7 29 83	171	75	6.8	6.6		340.0		605
8 1 83	174	1	6.9	6.6	34500.0		290	
8 2 83	175	2	7.1	7.1	24000.0	2400.0	365	470
8 3 83	176	3	7.1	6.9	37500.0	5700.0	320	360
8 4 83	177	4	7.2	6.8	25000.0	3500.0	370	471
8 5 83	178	5	7.1	6.8		1600.0		410
8 8 83	181	8	7.2	6.9	113500.0		1480	
8 9 83	182	9	7.2	6.7	129300.0	6900.0	1870	90
8 10 83	183	10	7.2	6.8	280000.0	16200.0	3760	175
8 11 83	184	11	7.2	6.7	110000.0	8000.0	1055	390
8 12 83	185	12	7.1	6.8		7500.0		405

THIS IS THE START OF PHASE III DATA FOR FILTER NO 1, THE CONTROL FILTER.

8 15 83	188	15	7.6	7.1	113000.0		1080	
8 16 83	189	16	7.8	7.2	73500.0	7700.0	1360	195
8 17 83	190	17	7.8	7.2	77000.0	7200.0	835	125
8 18 83	191	18	7.7	7.3		6200.0		235
8 22 83	195	22	8.7	7.3	65700.0		1085	
8 23 83	196	23	8.0	7.3	78000.0	7000.0	99	145
8 24 83	197	24	7.9	7.3	80500.0	6300.0	720	170
8 25 83	198	25	7.8	7.4		4600.0		140
8 29 83	202	29	8.0	7.4	70000.0		790	
8 30 83	203	30	7.9	7.4	70000.0	4200.0	990	25
9 1 83	204	31	8.1	7.4		4950.0		110
9 5 83	208	35	8.1	7.4	58000.0		1025	
9 6 83	209	36	8.1	7.4	75000.0	3100.0	795	85
9 7 83	210	37	8.0	7.4	80000.0	4850.0	790	113
9 26 83	229	56	7.6	6.7	123000.0		3140	
9 27 83	230	57	7.8	6.9	120000.0	1050.0	1225	130
9 28 83	231	58	7.5	7.3	70000.0	1400.0	1085	141
9 29 83	232	59	7.5	7.1		1650.0		40
9 30 83	233	60	7.4	7.1				
10 11 83	245	72	7.2	6.7	2.0		365	
10 12 83	246	73	7.2	6.7	4.0	1.0	584	101
10 13 83	247	74	7.4	6.6	0.0	0.0	415	114
10 14 83	248	75	7.5	6.6	3.4	0.0	268	101
10 15 83	249	76	7.7	6.7	2.6	.5	172	81
10 16 83	250	77	7.5	6.6	1.4	0.0	118	70
10 17 83	251	78	7.5	6.6	1.3	0.0	120	86
10 26 83	260	87	7.4	6.4	.7		96	
10 27 83	261	88	7.4	6.3	.7	0.0	56	86
11 5 83	270	97	7.3	6.4	.6		9	

(CONTINUED)

Table B-1. (continued).

DATE		DAYS OF CONTINUOUS OPERATION	AGE OF SCHMUTZDECKE (DAYS)	INFLUENT TURBIDITY (NTU)	EFFLUENT TURBIDITY (NTU)	INFLUENT COLIFORM (NO/100ML)	EFFLUENT COLIFORM (NO/100ML)	INFLUENT STD PLATE COUNT (NO/ML)	EFFLUENT STD PLATE COUNT (NO/ML)	
MO	DAY	YR	(DAYS)	(DAYS)	(NTU)	(NTU)	(NO/100ML)	(NO/ML)	(NO/ML)	
11	6	83	271	98	7.2	6.4	.6	.6	67	124
11	7	83	272	99	7.2	6.4	1540.0	.5	418	57
11	8	83	273	100	7.1	6.5	1530.0	40.0	93	152
11	9	83	274	101	7.2	6.5	2350.0	88.0	62	147
11	10	83	275	102	7.3	6.6	1950.0	90.0	52	79
11	13	83	278	105	7.3	6.7			13	
11	14	83	279	106	7.4	6.6			13	80
11	15	83	280	107	7.8	6.7			8	63
11	16	83	281	108	8.1	6.7			7	108
11	17	83	282	109	7.8	6.7			7	197
11	18	83	283	110	7.7	6.7			7	118
11	19	83	284	111	7.6	6.6			5	95
11	20	83	285	112	7.7	6.7			4	84
11	21	83	286	113	7.8	6.7			173500	124
11	22	83	287	114	8.0	6.7			205000	315
11	23	83	288	115	8.0	6.7			630000	500
11	24	83	289	116	7.8	6.5			525000	300
11	25	83	290	117	6.7	6.3			130000	315
11	26	83	291	118	7.2	6.1			108000	520
11	27	83	292	119	6.8	5.9			1385000	175
11	28	83	293	120	7.0	5.9			1510000	410
11	29	83	294	121	7.3	5.8			1145000	1910
11	30	83	295	122	7.4	5.8			1310000	580
12	1	83	296	123	7.4	5.8				870
12	14	83	309	136	5.3	4.3	2300.0		115	
12	15	83	310	137	5.4	4.3	2350.0	25.5	102	122
12	16	83	311	138	5.4	4.4	2900.0	19.0	201	118
12	17	83	312	139	5.3	4.5	2450.0	49.5	121	102
12	18	83	313	140	5.4	4.6	2600.0	32.0	143	102
12	19	83	314	141	5.3	4.5	2250.0	65.0	90	105
12	20	83	315	142	5.2	4.5	2300.0	20.0	115	78
12	21	83	316	143	5.4	4.4	2500.0	27.0	87	79
12	22	83	317	144	5.4	4.6	2150.0	40.0	126	82
12	23	83	318	145	5.5	4.7		65.0		115

Table B-2. Phase II slow sand filter data for Filter No. 2, this filter has 1/2 the sand depth.

DATE	DAYS OF CONTINUOUS OPERATION	AGE OF SCHMUTZDECKE	INFLUENT TURBIDITY	EFFLUENT TURBIDITY	INFLUENT COLIFORM	EFFLUENT COLIFORM	INFLUENT STD PLATE COUNT	EFFLUENT STD PLATE COUNT
MM DY YR	(DAYS)	(DAYS)	(NTU)	(NTU)	(NO/100ML)	(NO/100ML)	(NO/ML)	(NO/ML)
2 9 83	1	1	9.1	6.6				
2 10 83	2	2	9.1	8.0	2.0		240	3445
2 11 83	3	3	8.9	8.6	51000.0	0.0	1310	67000
2 12 83	4	4	9.0	8.1	7100.0	55500.0	755	116000
2 13 83	5	5	9.0	7.9	3400.0	4950.0	74	2900
2 14 83	6	6	8.7	7.9	4900.0		845.0	23350
2 15 83	7	7	8.8	8.0	5000.0	360.0	3620	12400
2 16 83	8	8	8.7	8.6	2250.0	420.0	4000	23600
2 17 83	9	9	8.6	9.2				
2 20 83	12	12	8.6	8.6	20000.0		3850	
2 21 83	13	13	8.6	8.5	14667.0	12350.0	365	2600
2 22 83	14	14	8.5	8.4	21000.0	8200.0	630	4200
2 23 83	15	15	8.6	8.3	37500.0	7100.0	635	10850
2 24 83	16	16	8.3	8.3	20500.0	24000.0	9650	2850
2 25 83	17	17	8.4	8.1		4750.0		320
2 27 83	19	19	8.3	8.2	1460.0		1015	
2 28 83	20	20	8.2	8.1	990.0	75.0	395	1845
3 1 83	21	21	8.0	7.9	6700.0	49.0	125	2350
3 2 83	22	22	7.8	7.7	2200.0	113.5	330	625
3 3 83	23	23	8.2	7.8	640.0	170.0	131	525
3 4 83	24	24	8.0	7.7		58.0		240
3 6 83	26	26	8.1		125.0		600	
3 7 83	27	27	7.4	7.7	48.0	2.0	44	1160
3 8 83	28	28	7.6	7.4	126.0	7.0	3045	7900
3 9 83	29	29	7.5	7.2	42.5	1.0	135	1080
3 10 83	30	30	7.6	7.1	2000.0	1.5	330	415
3 11 83	31	31	7.6	7.0		67.0		765
3 14 83	34	34	7.8	7.1	2650.0		415	
3 15 83	35	35	7.8	7.1	20000.0	45.0	945	1095
3 16 83	36	36	7.4	7.2	22000.0	2400.0	975	930
3 17 83	37	37	7.4	7.0		1160.0		1155
3 20 83	40	40	7.2	6.9	66000.0		595	
3 21 83	41	41	7.0	6.9	76500.0	3300.0	830	660
3 22 83	42	42	6.9	6.7	91500.0	3800.0	9950	810
3 23 83	43	43	6.8	6.7	61000.0	2900.0	700	645
3 24 83	44	44	6.7	6.7	66500.0	1700.0	775	860
3 25 83	45	45	6.7	6.3		1400.0		770
3 27 83	47	47	6.8	6.3	64000.0		850	
3 28 83	48	48	6.7	6.3	14000.0	1750.0	340	615
3 29 83	49	49	6.7	6.3		1250.0		710
4 5 83	56	56	7.3	6.6	3000.0		19200	
4 6 83	57	57	7.2	6.5	2200.0	8.0	1570	820
4 7 83	58	58	7.0	6.0	1100.0	7.0	1790	1360
4 8 83	59	59	7.0	6.1		27.0		840
4 11 83	62	62	6.8	6.5	3950.0		690	
4 12 83	63	63	6.8	6.5	3000.0	54.0	775	455
4 13 83	64	64	6.8	6.4	6700.0	130.0	285	460
4 14 83	65	65	6.7	6.4		44.0		370
4 16 83	67	1						
4 21 83	72	6	6.6	7.1				
4 22 83	73	7	6.4	6.8				
4 25 83	76	10	7.7	6.5	145000.0		1555	
4 26 83	77	11	6.9	6.6	125000.0	850.0	1375	325
4 27 83	78	12	6.5	6.4	215000.0	510.0	2285	155
4 28 83	79	13	6.4	6.3		1150.0		405
5 3 83	84	18	6.7	6.0				
5 4 83	85	19	6.6	6.0				
5 15 83	96	30	6.3	4.7				
5 16 83	97	1	6.3	4.7	113000.0		1460	
5 17 83	98	2	6.3	5.5	70500.0	6050.0	755	665
5 18 83	99	3	6.2	4.9	72500.0	4200.0	840	610
5 19 83	100	4	6.2	4.8	70000.0	4300.0	965	630
5 20 83	101	5	6.1	4.6		4050.0		60
5 23 83	104	8	6.1	4.1	63000.0		1145	
5 24 83	105	9	6.0	4.1	69000.0	1120.0	820	150
5 25 83	106	10	6.1	4.0	69000.0	1700.0	390	320
5 26 83	107	11	6.1	4.0	56500.0	1260.0	670	465
5 27 83	108	12	6.0	4.0		1140.0		625
5 30 83	111	15	6.1	4.1	64000.0		680	
5 31 83	112	16	6.1	4.1	52500.0	430.0	710	300

Table B-2. (continued).

DATE	DAYS OF CONTINUOUS OPERATION	AGE OF SCHMOTZDECKE (DAYS)	INFLUENT TURBIDITY (NTU)	EFFLUENT TURBIDITY (NTU)	INFLUENT COLIFORM (NO/100ML)	EFFLUENT COLIFORM (NO/100ML)	INFLUENT STD PLATE COUNT (NO/ML)	EFFLUENT STD PLATE COUNT (NO/ML)
MM DY YR	(DAYS)	(DAYS)	(NTU)	(NTU)	(NO/100ML)	(NO/100ML)	(NO/ML)	(NO/ML)
6 1 83	113	17	6.2	4.1	35500.0	2300.0	630	405
6 2 83	114	18	6.1	4.1		715.0		310
6 27 83	139	43	8.9	5.5	35000.0		515	
6 28 83	140	44	7.8	5.4	38000.0	420.0	660	775
6 29 83	141	45	7.4	5.3	49000.0	530.0	655	450
6 30 83	142	46	7.3	5.2	33000.0	1000.0	420	215
7 1 83	143	47	7.3	5.2		820.0		300
7 4 83	146	50	7.0	5.4	930.0		224	
7 5 83	147	51	7.0	5.5	2300.0	29.0	155	295
7 6 83	148	52	7.0	5.7	3200.0	75.0	150	225
7 7 83	149	53	7.0	5.7	4250.0	90.0	515	360
7 8 83	150	54	7.0	5.4		79.0		295
7 11 83	153	57	7.1	5.5	35.0		3000	
7 12 83	154	58	7.1	5.5	66.0	3.0	290	180
7 13 83	155	59	6.9	5.5	76.0	2.0	190	145
7 14 83	156	60	6.8	5.5	74.0	2.0	160	215
7 15 83	157	61	6.8	5.5	31.0	2.0	490	245
7 18 83	160	64	6.8	5.6	340.0		320	
7 19 83	161	65	6.7	5.9	230.0	16.0	345	220
7 20 83	162	66	6.6	6.0	290.0	19.0	340	265
7 21 83	163	67	6.8	6.0	310.0	15.0	180	260
7 22 83	164	68	6.8	6.0	2100.0	33.0	130	230
7 23 83	165	69	7.0	6.1	2300.0	390.0		
7 24 83	166	70	7.0	6.2	2300.0	150.0	350	
7 25 83	167	71	7.0	6.2	2000.0	200.0	307	120
7 26 83	168	72	6.8	6.4	20500.0	140.0	325	155
7 27 83	169	73	6.8	6.6	12000.0	790.0	485	180
7 28 83	170	74	6.8	6.6	6600.0	690.0	205	75
7 29 83	171	75	6.8	6.6		400.0		205
8 1 83	174	1	6.9	6.6	34500.0		290	
8 2 83	175	2	7.1	7.0	24000.0	3300.0	365	195
8 3 83	176	3	7.1	6.7	37500.0	6900.0	320	150
8 4 83	177	4	7.2	6.6	25000.0	3000.0	370	245
8 5 83	178	5	7.1	6.6		1800.0		175
8 8 83	181	8	7.2	6.7	113500.0		1480	
8 9 83	182	9	7.2	6.7	129300.0	7750.0	1870	140
8 10 83	183	10	7.2	6.7	280000.0	27000.0	3760	290
8 11 83	184	11	7.2	6.7	110000.0	8500.0	1055	270
8 12 83	185	12	7.1	6.7		11000.0		225

THIS IS THE START OF PHASE III DATA FOR FILTER NO. 2. THIS FILTER HAS A DIATOMACEOUS EARTH COATING

8 15 83	188	1	7.6	7.0	113000.0		1080	
8 16 83	189	2	7.8	7.2	73500.0	11300.0	1360	635
8 17 83	190	3	7.8	6.8	77000.0	5300.0	835	415
8 18 83	191	4	7.7	6.1		9000.0		1380
8 22 83	195	8	8.7	6.4	65700.0		1085	
8 23 83	196	9	8.0	6.1	78000.0	4100.0	99	150
8 24 83	197	10	7.9	5.8	80500.0	6800.0	720	90
8 25 83	198	11	7.8	5.6		4900.0		170
8 29 83	202	15	8.0	5.7	70000.0		790	
8 30 83	203	16	7.9	5.6	70000.0	3000.0	990	70
9 1 83	204	17	8.1	5.7		5050.0		190
9 5 83	208	21	8.1	6.0	58000.0		1025	
9 6 83	209	22	8.1	6.0	75000.0	2400.0	795	85
9 7 83	210	23	8.0	6.0	80000.0	3100.0	790	152
9 26 83	229	42	7.6	6.3	123000.0		3140	
9 27 83	230	43	7.8	6.5	120000.0	700.0	1225	175
9 28 83	231	44	7.5	6.9	70000.0	2300.0	1085	120
9 29 83	232	45	7.5	6.8		1300.0		32
9 30 83	233	46	7.4	6.8				
10 11 83	245	58	7.2	6.2	2.0		365	
10 12 83	246	59	7.2	6.2	4.0	1.0	584	75
10 13 83	247	60	7.4	6.2	0.0	0.0	415	163
10 14 83	248	61	7.5	6.3	3.4	0.0	268	95
10 15 83	249	62	7.7	6.3	2.6	.5	172	94
10 16 83	250	63	7.5	6.3	1.4	1.5	118	35
10 17 83	251	64	7.5	6.4	1.3	0.0	120	83
10 26 83	260	73	7.4	6.7	.7		96	
10 27 83	261	74	7.4	6.7	.7	0.0	56	38
11 5 83	270	83	7.3	6.7	.6		9	

(CONTINUED)

Table B-2. (continued).

DATE			DAYS OF CONTINUOUS OPERATION	AGE OF SCHMUTZDECKE (DAYS)	INFLUENT TURBIDITY (NTU)	EFFLUENT TURBIDITY (NTU)	INFLUENT COLIFORM (NO/100ML)	EFFLUENT COLIFORM (NO/100ML)	INFLUENT STD PLATE COUNT (NO/ML)	EFFLUENT STD PLATE COUNT (NO/ML)
11	6	83	271	84	7.2	6.8	.6	0.0	67	106
11	7	83	272	85	7.2	6.8	1540.0	0.0	418	56
11	8	83	273	86	7.1	6.8	1530.0	24.0	93	81
11	9	83	274	87	7.2	6.7	2350.0	34.0	62	106
11	10	83	275	88	7.3	6.7	1950.0	33.0	52	29
11	13	83	278	91	7.3				13	
11	14	83	279	92	7.4				13	
11	15	83	280	93	7.8				8	
11	16	83	281	94	8.1				7	
11	17	83	282	95	7.8				7	
11	18	83	283	96	7.7				7	
11	19	83	284	97	7.6				5	
11	20	83	285	98	7.7				4	
11	21	83	286	99	7.8				173500	
11	22	83	287	100	8.0				205000	
11	23	83	288	101	8.0				630000	
11	24	83	289	102	7.8				525000	
11	25	83	290	103	6.7				130000	
11	26	83	291	104	7.2				108000	
11	27	83	292	105	6.8				1385000	
11	28	83	293	106	7.0				1510000	
11	29	83	294	107	7.3				1145000	
11	30	83	295	108	7.4				1310000	
12	1	83	296	109	7.4					
12	14	83	309	122	5.3	2300.0			115	
12	15	83	310	123	5.4	2350.0			102	
12	16	83	311	124	5.4	2900.0			201	
12	17	83	312	125	5.3	2450.0			121	
12	18	83	313	126	5.4	2600.0			143	
12	19	83	314	127	5.3	2250.0			90	
12	20	83	315	128	5.2	2300.0			115	
12	21	83	316	129	5.4	2500.0			87	
12	22	83	317	130	5.4	2150.0			126	
12	23	83	318	131	5.5					

Table B-3. Phase II slow sand filter data for Filter No. 3, this filter had chlorine added when tests were not being performed.

DATE	DAYS OF CONTINUOUS OPERATION (DAYS)	AGE OF SCHMUTZDECKE (DAYS)	INFLUENT TURBIDITY (NTU)	EFFLUENT TURBIDITY (NTU)	INFLUENT COLIFORM (NO/100ML)	EFFLUENT COLIFORM (NO/100ML)	INFLUENT STD PLATE COUNT (NO/ML)	EFFLUENT STD PLATE COUNT (NO/ML)
2 9 83	1	1	9.1	6.4				
2 10 83	2	2	9.1	7.9	2.0		240	
2 11 83	3	3	8.9	8.1	51000.0		1310	
2 12 83	4	4	9.0	8.0	7100.0		755	
2 13 83	5	5	9.0	8.1	3400.0		74	
2 14 83	6	6	8.7	7.9	4900.0		985	
2 15 83	7	7	8.8	7.9	5000.0		3620	
2 16 83	8	8	8.7	7.6	2250.0		4000	
2 17 83	9	9	8.6	8.0				
2 20 83	12	12	8.6	7.6	20000.0		3850	
2 21 83	13	13	8.6	7.5	14667.0		365	
2 22 83	14	14	8.5	7.6	21000.0		630	
2 23 83	15	15	8.6	7.5	37500.0		635	
2 24 83	16	16	8.3	7.5	20500.0		9650	
2 25 83	17	17	8.4	7.4				
2 27 83	19	19	8.3	7.4	1460.0		1015	
2 28 83	20	20	8.2	7.3	990.0		395	
3 1 83	21	21	8.0	7.1	6700.0		125	
3 2 83	22	22	7.8	7.2	2200.0		330	
3 3 83	23	23	8.2	7.3	640.0		131	
3 4 83	24	24	8.0	7.2				
3 6 83	26	26	8.1		125.0		600	
3 7 83	27	27	7.4	7.1	48.0		44	
3 8 83	28	28	7.6	7.0	126.0		3045	
3 9 83	29	29	7.5	6.8	42.5		135	
3 10 83	30	30	7.6	6.9	2000.0		330	
3 11 83	31	31	7.6	6.7				
3 14 83	34	34	7.8	6.7	2650.0		415	
3 15 83	35	35	7.8	6.7	20000.0		945	
3 16 83	36	36	7.4	6.8	22000.0		975	
3 17 83	37	37	7.4	6.5				
3 20 83	40	40	7.2	6.4	66000.0		595	
3 21 83	41	41	7.0	6.3	76500.0		830	
3 22 83	42	42	6.9	6.4	91500.0		9950	
3 23 83	43	43	6.8	6.3	61000.0		700	
3 24 83	44	44	6.7	6.3	66500.0		775	
3 25 83	45	45	6.7	5.8				
3 27 83	47	47	6.8	5.8	64000.0		850	
3 28 83	48	48	6.7	5.9	14000.0		340	
3 29 83	49	49	6.7	5.9				
4 5 83	56	56	7.3	6.6	3000.0		19200	
4 6 83	57	57	7.2	7.5	2200.0	480.0	1570	10000
4 7 83	58	58	7.0	8.0	1100.0	75.0	1790	18050
4 8 83	59	59	7.0	10.5		540.0		24300
4 11 83	62	62	6.8	5.9	3950.0		690	
4 12 83	63	63	6.8	5.9	3000.0		775	
4 13 83	64	64	6.8	5.9	6700.0		285	
4 14 83	65	65	6.7	5.9				
4 16 83	67	1						
4 21 83	72	6	6.6	6.1				
4 22 83	73	7	6.4	5.8				
4 25 83	76	10	7.7	6.3	145000.0		1555	
4 26 83	77	11	6.9	6.4	125000.0		1375	
4 27 83	78	12	6.5	6.2	215000.0		2285	
4 28 83	79	13	6.4	6.1				
5 3 83	84	18	6.7	5.6				
5 4 83	85	19	6.6	5.9				
5 15 83	96	30	6.3	5.6				
5 16 83	97	1	6.3	5.7	113000.0		1460	
5 17 83	98	2	6.3	5.8	70500.0	71500.0	755	710
5 18 83	99	3	6.2	6.0	72500.0	58000.0	840	780
5 19 83	100	4	6.2	6.2	70000.0	69500.0	965	3650
5 20 83	101	5	6.1	7.2		49500.0		2750
5 23 83	104	8	6.1	5.6	63000.0		1145	
5 24 83	105	9	6.0	5.7	69000.0	51000.0	820	360
5 25 83	106	10	6.1	5.5	69000.0	30500.0	390	310
5 26 83	107	11	6.1	5.7	56500.0	42000.0	670	950
5 27 83	108	12	6.0	5.9		32500.0		3850
5 30 83	111	15	6.1	5.4	64000.0		680	
5 31 83	112	16	6.1	5.4	52500.0	24000.0	710	100

(CONTINUED)

Table B-3. (continued).

DATE	DAYS OF CONTINUOUS OPERATION	AGE OF SCHMUTZDECKE (DAYS)	INFLUENT TURBIDITY (NTU)	EFFLUENT TURBIDITY (NTU)	INFLUENT COLIFORM (NO/100ML)	EFFLUENT COLIFORM (NO/100ML)	INFLUENT STD PLATE COUNT (NO/ML)	EFFLUENT STD PLATE COUNT (NO/ML)
MM BY YR	(DAYS)	(DAYS)	(NTU)	(NTU)	(NO/100ML)	(NO/100ML)	(NO/ML)	(NO/ML)
6 1 83	113	17	6.2	5.5	35500.0	33000.0	630	980
6 2 83	114	18	6.1	5.7		27000.0		1480
6 27 83	139	43	8.9	7.5	35000.0		515	
6 28 83	140	44	7.8	7.1	38000.0	12000.0	660	525
6 29 83	141	45	7.4	6.4	49000.0	24000.0	655	1530
6 30 83	142	46	7.3	6.9	33000.0	18000.0	420	2310
7 1 83	143	47	7.3	8.1		20000.0		3545
7 4 83	146	50	7.0	6.3	930.0		224	
7 5 83	147	51	7.0	6.3	2300.0	450.0	155	55
7 6 83	148	52	7.0	6.4	3200.0	1040.0	150	930
7 7 83	149	53	7.0	6.8	4250.0	1600.0	515	1695
7 8 83	150	54	7.0	7.2		790.0		3110
7 11 83	153	57	7.1	6.1	35.0		3000	
7 12 83	154	58	7.1	6.1	66.0	19.0	280	780
7 13 83	155	59	6.9	6.5	76.0	13.0	190	1755
7 14 83	156	60	6.8	7.3	74.0	7.0	160	429
7 15 83	157	61	6.8	7.8	31.0	12.0	490	4340
7 18 83	160	64	6.8	6.3	340.0		320	
7 19 83	161	65	6.7	6.3	230.0	130.0	345	85
7 20 83	162	66	6.6	6.3	290.0	86.0	340	760
7 21 83	163	67	6.8	6.9	310.0	110.0	180	1510
7 22 83	164	68	6.8	7.3	2100.0	200.0	130	174
7 23 83	165	69	7.0	6.0	2300.0			
7 24 83	166	70	7.0	6.0	2300.0	1300.0	350	
7 25 83	167	71	7.0	6.1	2000.0	1400.0	307	225
7 26 83	168	72	6.8	6.6	20500.0	1500.0	325	870
7 27 83	169	73	6.8	6.8	12000.0	5300.0	485	985
7 28 83	170	74	6.8	7.1	6600.0	4800.0	205	235
7 29 83	171	75	6.8	6.2				
8 1 83	174	1	6.9	6.2	34500.0		290	
8 2 83	175	2	7.1	6.3	24000.0	18700.0	365	455
8 3 83	176	3	7.1	6.8	37500.0	37500.0	320	870
8 4 83	177	4	7.2	6.9	25000.0	36000.0	370	1305
8 5 83	178	5	7.1	7.2		6000.0		5870
8 8 83	181	8	7.2	6.0	113500.0		1480	
8 9 83	182	9	7.2	6.4	129300.0	58000.0	1870	560
8 10 83	183	10	7.2	6.8	280000.0	56000.0	3760	2460
8 11 83	184	11	7.2	7.1	110000.0	54000.0	1055	387
8 12 83	185	12	7.1	7.3		50000.0		2580

THIS IS THE START OF PHASE III DATA FOR FILTER 3, THIS FILTER HAD SMALL SAND (0.128mm).

8 15 83	188	1	7.6	7.3	113000.0		1080	
8 16 83	189	2	7.8	24.0	73500.0	61000.0	1360	324
8 17 83	190	3	7.8	23.5	77000.0	40000.0	835	750
8 18 83	191	4	7.7	23.0		53000.0		1685
8 22 83	195	8	8.7	15.8	65700.0		1085	
8 23 83	196	9	8.0	13.8	78000.0	33000.0	99	905
8 24 83	197	10	7.9	12.0	80500.0	32000.0	720	285
8 25 83	198	11	7.8	11.3		35000.0		730
8 29 83	202	15	8.0	9.1	70000.0		790	
8 30 83	203	16	7.9	9.0	70000.0	23000.0	990	410
9 1 83	204	17	8.1	8.1		24000.0		575
9 5 83	208	21	8.1	7.9	58000.0		1025	
9 6 83	209	22	8.1	7.9	75000.0	7400.0	795	235
9 7 83	210	23	8.0	7.8	80000.0	20000.0	790	295
9 26 83	229	42	7.6	9.7	123000.0		3140	
9 27 83	230	43	7.8	9.8	120000.0	7000.0	1225	500
9 28 83	231	44	7.5	10.0	70000.0	14000.0	1085	455
9 29 83	232	45	7.5	10.0		9800.0		340
9 30 83	233	46	7.4	9.9				
10 11 83	245	58	7.2	10.1	2.0		365	
10 12 83	246	59	7.2	10.2	4.0	1.0	584	310
10 13 83	247	60	7.4	10.5	0.0	0.0	415	319
10 14 83	248	61	7.5	10.4	3.4	0.0	268	296
10 15 83	249	62	7.7	10.6	2.6	0.0	172	381
10 16 83	250	63	7.5	10.5	1.4	0.0	118	372
10 17 83	251	64	7.5	10.7	1.3	0.0	120	350
10 26 83	260	73	7.4	10.5	.7		96	
10 27 83	261	74	7.4	10.6	.7	0.0	56	258
11 5 83	270	83	7.3	9.4	.6		9	

(CONTINUED)

Table B-3. (continued).

DATE	DAYS OF CONTINUOUS OPERATION	AGE OF SCHMUTZDECKE (DAYS)	INFLUENT TURBIDITY (NTU)	EFFLUENT TURBIDITY (NTU)	INFLUENT COLIFORM (NO/100ML)	EFFLUENT COLIFORM (NO/100ML)	INFLUENT STD PLATE COUNT (NO/ML)	EFFLUENT STD PLATE COUNT (NO/ML)
MM DY YR	(DAYS)	(DAYS)	(NTU)	(NTU)	(NO/100ML)	(NO/100ML)	(NO/ML)	(NO/ML)
11 6 83	271	84	7.2	9.4	.6	0.0	67	296
11 7 83	272	85	7.2	9.2	1540.0	0.0	418	250
11 8 83	273	86	7.1	9.1	1530.0	125.0	93	570
11 9 83	274	87	7.2	9.0	2350.0	230.0	62	414
11 10 83	275	88	7.3	9.1	1950.0	170.0	52	157
11 13 83	278	91	7.3	9.0			13	
11 14 83	279	92	7.4	9.1			13	444
11 15 83	280	93	7.8	8.7			8	456
11 16 83	281	94	8.1	8.2			7	482
11 17 83	282	95	7.8	8.3			7	408
11 18 83	283	1	7.7				7	
11 19 83	284	2	7.6	8.6			5	
11 20 83	285	3	7.7	8.7			4	
11 21 83	286	4	7.8	8.5			173500	
11 22 83	287	5	8.0	8.5			205000	2800
11 23 83	288	6	8.0	8.5			630000	3600
11 24 83	289	7	7.8	8.5			525000	2160
11 25 83	290	8	6.7	8.4			130000	1900
11 26 83	291	9	7.2	7.9			108000	3700
11 27 83	292	10	6.8	7.5			1385000	810
11 28 83	293	11	7.0	7.5			1510000	1280
11 29 83	294	12	7.3	7.3			1145000	2100
11 30 83	295	13	7.4	7.3			1310000	2800
12 1 83	296	14	7.4	7.3				2050
12 14 83	309	27	5.3	4.4	2300.0		115	
12 15 83	310	28	5.4	4.2	2350.0	9.5	102	105
12 16 83	311	29	5.4	4.5	2900.0	2.5	201	155
12 17 83	312	30	5.3	4.4	2450.0	26.0	121	92
12 18 83	313	31	5.4	4.4	2600.0	17.0	143	142
12 19 83	314	32	5.3	4.4	2250.0	28.5	90	103
12 20 83	315	33	5.2	4.5	2300.0	7.0	115	116
12 21 83	316	34	5.4	4.7	2500.0	19.0	87	120
12 22 83	317	35	5.4	4.8	2150.0	37.5	126	123
12 23 83	318	36	5.5	4.8		38.5		122



Table B-4. Phase II slow sand filter data for Filter No. 4, this filter had nutrients added.

DATE	DAYS OF CONTINUOUS OPERATION	AGE OF SCHMUTZDECKE (DAYS)	INFLUENT TURBIDITY (NTU)	EFFLUENT TURBIDITY (NTU)	INFLUENT COLIFORM (NO/100ML)	EFFLUENT COLIFORM (NO/100ML)	INFLUENT STD PLATE COUNT (NO/ML)	EFFLUENT STD PLATE COUNT (NO/ML)
MM DY YR	(DAYS)	(DAYS)	(NTU)	(NTU)	(NO/100ML)	(NO/100ML)	(NO/ML)	(NO/ML)
2 9 83	1	1	9.1	6.7				
2 10 83	2	2	9.1	8.5	2.0		240	14500
2 11 83	3	3	8.9	9.6	51000.0	0.0	1310	
2 12 83	4	4	9.0	5.3	7100.0	39000.0	755	4030000
2 13 83	5	5	9.0	5.9	3400.0	10300.0	74	12000
2 14 83	6	6	8.7	6.9	4900.0	2350.0	985	8000
2 15 83	7	1	8.8	8.4	5000.0		3620	
2 16 83	8	2	8.7	8.4	2250.0	1350.0	4000	15200
2 17 83	9	3	8.6	10.0				
2 20 83	12	6	8.6	7.5	20000.0		3850	
2 21 83	13	7	8.6	8.1	14667.0	100.0	365	3600
2 22 83	14	8	8.5	8.0	21000.0	12.5	630	1820
2 23 83	15	9	8.6	8.0	37500.0	5.5	635	3000
2 24 83	16	10	8.3	8.0	20500.0	17.0	9650	3300
2 25 83	17	11	8.4	8.3		4.5		560
2 27 83	19	13	8.3	8.1	1460.0		1015	
2 28 83	20	14	8.2	7.7	990.0	2.0	395	2040
3 1 83	21	15	8.0	6.6	6700.0	5.0	125	900
3 2 83	22	16	7.8	6.5	2200.0	9.0	330	340
3 3 83	23	17	8.2	6.1	640.0	0.0	131	215
3 4 83	24	18	8.0	5.1		0.0		240
3 6 83	26	20	8.1		125.0		600	
3 7 83	27	21	7.4	5.2	48.0	0.0	44	740
3 8 83	28	22	7.6	4.8	126.0	0.0	3045	1510
3 9 83	29	23	7.5	4.4	42.5	0.0	135	310
3 10 83	30	24	7.6	4.8	2000.0	0.0	330	325
3 11 83	31	25	7.6	5.0		.5		905
3 14 83	34	28	7.8	5.1	2650.0		415	
3 15 83	35	29	7.8	5.1	20000.0	0.0	945	480
3 16 83	36	30	7.4	5.1	22000.0	26.0	975	875
3 17 83	37	31	7.4	4.9		12.0		1765
3 20 83	40	34	7.2	4.3	66000.0		595	
3 21 83	41	35	7.0	4.0	76500.0	6.0	830	480
3 22 83	42	36	6.9	4.0	91500.0	9.0	9950	920
3 23 83	43	37	6.8	4.1	61000.0	9.0	700	385
3 24 83	44	38	6.7	4.1	66500.0	16.0	775	70
3 25 83	45	39	6.7	4.0		12.0		2500
3 27 83	47	41	6.8	4.0	64000.0		850	
3 28 83	48	42	6.7	4.0	14000.0	97.0	340	505
3 29 83	49	43	6.7	4.0		15.0		265
4 5 83	56	50	7.3	3.5	3000.0		19200	
4 6 83	57	51	7.2	3.7	2200.0	4.0	1570	690
4 7 83	58	52	7.0	3.4	1100.0	1.0	1790	810
4 8 83	59	53	7.0	3.2		3.0		305
4 11 83	62	56	6.8	4.3	3950.0		690	
4 12 83	63	57	6.8	4.3	3000.0	3.0	775	320
4 13 83	64	58	6.8	4.3	6700.0	5.0	285	585
4 14 83	65	59	6.7	4.2		2.0		750
4 16 83	67	1						
4 21 83	72	6	6.6	4.9				
4 22 83	73	7	6.4	4.6				
4 25 83	76	10	7.7	4.1	145000.0		1555	
4 26 83	77	11	6.9	4.0	125000.0	7.0	1375	140
4 27 83	78	12	6.5	3.8	215000.0	2.0	2285	85
4 28 83	79	13	6.4	3.4		13.0		91
5 3 83	84	1	6.7	4.3				
5 4 83	85	2	6.6	4.1				
5 15 83	96	13	6.3	2.4				
5 16 83	97	1	6.3	2.2	113000.0		1460	
5 17 83	98	2	6.3	3.1	70500.0	66.0	755	310
5 18 83	99	3	6.2	2.8	72500.0	58.0	840	100
5 19 83	100	4	6.2	2.8	70000.0	250.0	965	410
5 20 83	101	5	6.1	2.8		245.0		20
5 23 83	104	8	6.1	2.4	63000.0		1145	
5 24 83	105	9	6.0	2.5	69000.0	23.0	820	125
5 25 83	106	10	6.1	2.4	69000.0	12.0	390	180
5 26 83	107	11	6.1	2.4	56500.0	14.0	670	260
5 27 83	108	12	6.0	2.5		9.0		345
5 30 83	111	15	6.1	2.5	64000.0		680	
5 31 83	112	16	6.1	2.5	52500.0	2.0	710	205

(CONTINUE)

Table B-4. (continued).

DATE	DAYS OF CONTINUOUS OPERATION	AGE OF SCHMITZDECKE	INFLUENT TURBIDITY	EFFLUENT TURBIDITY	INFLUENT COLIFORM	EFFLUENT COLIFORM	INFLUENT STD PLATE COUNT	EFFLUENT STD PLATE COUNT
MM DY YR	(DAYS)	(DAYS)	(NTU)	(NTU)	(NO/100ML)	(NO/100ML)	(NO/ML)	(NO/ML)
6 1 83	113	17	6.2	2.4	35500.0	27.0	630	460
6 2 83	114	18	6.1	2.4		5.0		420
6 27 83	139	43	8.9	2.8	35000.0		515	
6 28 83	140	44	7.8	2.7	38000.0	4.0	660	255
6 29 83	141	45	7.4	2.7	49000.0	3.0	655	185
6 30 83	142	46	7.3	2.8	33000.0	7.0	420	115
7 1 83	143	47	7.3	3.0		11.0		110
7 4 83	146	50	7.0	3.2	930.0		224	
7 5 83	147	51	7.0	3.2	2300.0	0.0	155	160
7 6 83	148	52	7.0	3.3	3200.0	0.0	150	110
7 7 83	149	53	7.0	3.3	4250.0	.5	515	745
7 8 83	150	54	7.0	3.3		0.0		125
7 11 83	153	57	7.1	4.2	35.0		3000	
7 12 83	154	58	7.1	4.3	66.0	0.0	280	75
7 13 83	155	59	6.9	3.9	76.0	0.0	190	55
7 14 83	156	60	6.8	3.8	74.0	0.0	160	90
7 15 83	157	61	6.8	3.7	31.0	0.0	490	1100
7 18 83	160	64	6.8	3.2	340.0		320	
7 19 83	161	65	6.7	3.6	230.0	.5	345	190
7 20 83	162	66	6.6	3.6	290.0	0.0	340	205
7 21 83	163	67	6.8	3.6	310.0	0.0	180	55
7 22 83	164	68	6.8	3.6	2100.0	0.0	130	175
7 23 83	165	69	7.0	3.5	2300.0	2.0		
7 24 83	166	70	7.0	3.5	2300.0	2.0	350	
7 25 83	167	71	7.0	3.4	2000.0	2.0	307	150
7 26 83	168	72	6.8	3.6	20500.0	3.0	325	90
7 27 83	169	73	6.8	3.9	12000.0	12.0	485	100
7 28 83	170	74	6.8	3.7	6600.0	9.0	205	100
7 29 83	171	75	6.8	3.8		6.0		55
8 1 83	174	1	6.9	3.8	34500.0		290	
8 2 83	175	2	7.1	4.6	24000.0	330.0	365	85
8 3 83	176	3	7.1	3.7	37500.0	360.0	320	90
8 4 83	177	4	7.2	3.7	25000.0	230.0	370	70
8 5 83	178	5	7.1	3.4		35.0		50
8 8 83	181	8	7.2	3.4	113500.0		1480	
8 9 83	182	9	7.2	3.7	129300.0	20.0	1870	15
8 10 83	183	10	7.2	3.8	280000.0	28.0	3760	25
8 11 83	184	11	7.2	3.8	110000.0	260.0	1055	340
8 12 83	185	12	7.1	3.9		51.0		295

THIS IS THE START OF PHASE III DATA FOR FILTER NO 4, THIS FILTER WAS USED AS A SECOND CONTROL.

8 15 83	188	15	7.6	3.9	113000.0		1080	
8 16 83	189	16	7.8	5.1	73500.0	130.0	1360	120
8 17 83	190	17	7.8	6.0	77000.0	195.0	835	25
8 18 83	191	18	7.7	7.1		320.0		140
8 22 83	195	22	8.7	8.1	65700.0		1085	
8 23 83	196	23	8.0	8.1	78000.0	870.0	99	130
8 24 83	197	24	7.9	8.0	80500.0	910.0	720	110
8 25 83	198	25	7.8	8.1		1390.0		105
8 29 83	202	29	8.0	8.5	70000.0		790	
8 30 83	203	30	7.9	8.6	70000.0	1210.0	990	125
9 1 83	204	31	8.1	8.2		1500.0		135
9 5 83	208	35	8.1	8.1	58000.0		1025	
9 6 83	209	36	8.1	8.1	75000.0	1300.0	795	45
9 7 83	210	37	8.0	8.0	80000.0	2200.0	790	75
9 26 83	229	56	7.6	7.2	123000.0		3140	
9 27 83	230	57	7.8	8.0	120000.0	610.0	1225	110
9 28 83	231	58	7.5	8.1	70000.0	1600.0	1085	168
9 29 83	232	59	7.5	7.7		1300.0		80
9 30 83	233	60	7.4	7.7				
10 11 83	245	72	7.2	6.7	2.0		365	
10 12 83	246	73	7.2	6.6	4.0	0.0	584	88
10 13 83	247	74	7.4	6.7	0.0	.5	415	394
10 14 83	248	75	7.5	6.8	3.4	0.0	268	286
10 15 83	249	76	7.7	6.7	2.6	0.0	172	362
10 16 83	250	77	7.5	6.8	1.4	.5	118	88
10 17 83	251	78	7.5	7.0	1.3	0.0	120	344
10 26 83	260	87	7.4	6.9	.7		96	
10 27 83	261	88	7.4	6.9	.7	0.0	56	115
11 5 83	270	97	7.3	7.3	.6		9	

(CONTINUE)

Table B-4. (continued).

DATE	DAYS OF CONTINUOUS OPERATION	AGE OF SCHMUTZDECKE (DAYS)	INFLUENT TURBIDITY (NTU)	EFFLUENT TURBIDITY (NTU)	INFLUENT COLIFORM (NO/100ML)	EFFLUENT COLIFORM (NO/100ML)	INFLUENT STD PLATE COUNT (NO/ML)	EFFLUENT STD PLATE COUNT (NO/ML)
11 6 83	271	98	7.2	7.3	.6	0.0	67	176
11 7 83	272	99	7.2	7.3	1540.0	0.0	418	143
11 8 83	273	100	7.1	7.3	1530.0	45.0	93	234
11 9 83	274	101	7.2	7.3	2350.0	69.0	62	273
11 10 83	275	102	7.3	7.3	1950.0	91.0	52	117
11 13 83	278	105	7.3	7.1			13	
11 14 83	279	106	7.4	7.0			13	271
11 15 83	280	107	7.8	6.8			8	217
11 16 83	281	108	8.1	6.7			7	238
11 17 83	282	109	7.8	6.6			7	296
11 18 83	283	110	7.7	6.5			7	278
11 19 83	284	111	7.6	6.6			5	215
11 20 83	285	112	7.7	6.5			4	219
11 21 83	286	113	7.8	6.5			173500	285
11 22 83	287	114	8.0	6.6			205000	195
11 23 83	288	115	8.0	6.6			630000	485
11 24 83	289	116	7.8	6.6			525000	620
11 25 83	290	117	6.7	6.5			130000	310
11 26 83	291	118	7.2	6.5			108000	470
11 27 83	292	119	6.8	6.6			1385000	195
11 28 83	293	120	7.0	6.3			1510000	325
11 29 83	294	121	7.3	6.2			1145000	510
11 30 83	295	122	7.4	6.2			1310000	575
12 1 83	296	123	7.4	6.3				495
12 14 83	309	136	5.3	5.1	2300.0		115	
12 15 83	310	137	5.4	5.2	2350.0	27.5	102	92
12 16 83	311	138	5.4	5.2	2900.0	7.0	201	108
12 17 83	312	139	5.3	5.3	2450.0	75.5	121	117
12 18 83	313	140	5.4	5.4	2600.0	37.0	143	130
12 19 83	314	141	5.3	5.4	2250.0	75.5	90	96
12 20 83	315	142	5.2	5.5	2300.0	20.0	115	100
12 21 83	316	143	5.4	5.3	2500.0	21.0	87	104
12 22 83	317	144	5.4	5.3	2150.0	68.5	126	101
12 23 83	318	145	5.5	5.2		66.5		123

LIBRARY  
INTERNATIONAL REFERENCE CENTRE  
FOR COMMUNITY WATER SUPPLY AND  
SANITATION (IWC)

Table B-5. Phase II slow sand filter data for Filter No. 5, this filter had large sand and was operated at 5°C.

DATE	DAYS OF CONTINUOUS OPERATION	AGE OF SCHMUTZDECKE (DAYS)	INFLUENT TURBIDITY (NTU)	EFFLUENT TURBIDITY (NTU)	INFLUENT COLIFORM (NO/100ML)	EFFLUENT COLIFORM (NO/100ML)	INFLUENT STD PLATE COUNT (NO/ML)	EFFLUENT STD PLATE COUNT (NO/ML)
2 9 83	1	1	9.1	6.8				
2 10 83	2	2	9.1	8.1	2.0		240	5150
2 11 83	3	3	8.9	8.4	51000.0	0.0	1310	1440
2 12 83	4	4	9.0	8.4	7100.0	79000.0	755	8300
2 13 83	5	5	9.0	8.3	3400.0	5600.0	74	1000
2 14 83	6	6	8.7	8.1	4900.0	100.0	985	1780
2 15 83	7	7	8.8	8.2	5000.0	1195.0	3620	2005
2 16 83	8	8	8.7	8.0	2250.0	2350.0	4000	2645
2 17 83	9	9	8.6	7.8				
2 20 83	12	12	8.6	7.9	20000.0		3850	
2 21 83	13	13	8.6	7.8	14667.0	4900.0	365	1290
2 22 83	14	14	8.5	7.7	21000.0	8050.0	630	2580
2 23 83	15	15	8.6	7.7	37500.0	7700.0	635	410
2 24 83	16	16	8.3	7.7	20500.0	28000.0	9650	1840
2 25 83	17	17	8.4	7.6		4600.0		170
2 27 83	19	19	8.3	7.6	1460.0		1015	
2 28 83	20	20	8.2	7.6	990.0	375.0	395	1950
3 1 83	21	21	8.0	7.5	6700.0	101.0	125	1610
3 2 83	22	22	7.8	7.6	2200.0	4300.0	330	985
3 3 83	23	23	8.2	7.7	640.0	510.0	131	720
3 4 83	24	24	8.0	7.7		165.0		565
3 6 83	26	26	8.1		125.0		600	
3 7 83	27	27	7.4	7.7	48.0	13.5	44	1100
3 8 83	28	28	7.6	7.4	126.0	20.0	3045	875
3 9 83	29	29	7.5	7.3	42.5	28.5	135	540
3 10 83	30	30	7.6	7.4	2000.0	13.0	330	320
3 11 83	31	31	7.6	7.3		530.0		750
3 14 83	34	34	7.8	7.6	2650.0		415	
3 15 83	35	35	7.8	7.7	20000.0	410.0	945	410
3 16 83	36	36	7.4	7.9	22000.0	8400.0	975	740
3 17 83	37	37	7.4	7.7		8150.0		690
3 20 83	40	40	7.2	7.3	66000.0		595	
3 21 83	41	41	7.0	7.2	76500.0	36000.0	830	155
3 22 83	42	42	6.9	7.2	91500.0	27500.0	9950	385
3 23 83	43	43	6.8	7.1	61000.0	36500.0	700	500
3 24 83	44	44	6.7	7.1	66500.0	16000.0	775	145
3 25 83	45	45	6.7	6.8		25000.0		350
3 27 83	47	47	6.8	6.9	64000.0		850	
3 28 83	48	48	6.7	6.7	14000.0	2950.0	340	435
3 29 83	49	49	6.7	6.7		1600.0		145
4 5 83	56	56	7.3	6.4	3000.0		19200	
4 6 83	57	57	7.2	6.5	2200.0	405.0	1570	3400
4 7 83	58	58	7.0	6.5	1100.0	14.0	1790	4000
4 8 83	59	59	7.0	6.2		22.0		490
4 11 83	62	62	6.8	6.2	3950.0		690	
4 12 83	63	63	6.8	6.2	3000.0	180.0	775	25
4 13 83	64	64	6.8	6.1	6700.0	185.0	285	110
4 14 83	65	65	6.7	6.3		125.0		50
4 16 83	67	1						
4 21 83	72	6	6.6	6.2				
4 22 83	73	7	6.4	6.1				
4 25 83	76	10	7.7	6.6	145000.0		1555	
4 26 83	77	11	6.9	6.6	125000.0	4200.0	1375	80
4 27 83	78	12	6.5	6.4	215000.0	3400.0	2285	150
4 28 83	79	13	6.4	6.3		3150.0		103
5 3 83	84	18	6.7	6.2				
5 4 83	85	19	6.6	6.1				
5 15 83	96	30	6.3	5.7				
5 16 83	97	1	6.3	5.8	113000.0		1460	
5 17 83	98	2	6.3	5.8	70500.0	22500.0	755	215
5 18 83	99	3	6.2	5.8	72500.0	18000.0	840	260
5 19 83	100	4	6.2	5.8	70000.0	13450.0	965	265
5 20 83	101	5	6.1	5.8		18000.0		155
5 23 83	104	8	6.1	5.7	63000.0		1145	
5 24 83	105	9	6.0	5.7	69000.0	10500.0	820	155
5 25 83	106	10	6.1	5.7	69000.0	10300.0	390	75
5 26 83	107	11	6.1	5.7	56500.0	16000.0	670	215
5 27 83	108	12	6.0	5.8		9870.0		70
5 30 83	111	15	6.1	5.7	64000.0		680	
5 31 83	112	16	6.1	5.7	52500.0	4700.0	710	50

(CONTINUED)

Table B-5. (continued).

DATE	DAYS OF CONTINUOUS OPERATION	AGE OF SCHMIDTSCHE	INFLUENT TURBIDITY	EFFLUENT TURBIDITY	INFLUENT COLIFORM	EFFLUENT COLIFORM	INFLUENT STD PLATE COUNT	EFFLUENT STD PLATE COUNT
MM DY YR	(DAYS)	(DAYS)	(NTU)	(NTU)	(NO/100ML)	(NO/100ML)	(NO/ML)	(NO/ML)
6 1 83	113	17	6.2	5.7	35500.0	10450.0	630	145
6 2 83	114	18	6.1	5.7		6050.0		65
6 27 83	139	43	8.9	7.5	35000.0		515	
6 28 83	140	44	7.8	7.0	38000.0	3100.0	660	425
6 29 83	141	45	7.4	6.6	49000.0	5200.0	655	170
6 30 83	142	46	7.3	6.5	33000.0	5400.0	420	35
7 1 83	143	47	7.3	6.5		7200.0		100
7 4 83	146	50	7.0	6.4	930.0		224	
7 5 83	147	51	7.0	6.5	2300.0	320.0	155	60
7 6 83	148	52	7.0	6.5	3200.0	500.0	150	25
7 7 83	149	53	7.0	6.4	4250.0	560.0	515	60
7 8 83	150	54	7.0	6.4		320.0		10
7 11 83	153	57	7.1	6.2	35.0		3000	
7 12 83	154	58	7.1	6.2	66.0	28.0	280	65
7 13 83	155	59	6.9	6.2	76.0	25.0	190	50
7 14 83	156	60	6.8	6.2	74.0	7.0	160	25
7 15 83	157	61	6.8	6.2	31.0	13.0	490	155
7 18 83	160	64	6.8	6.3	340.0		320	
7 19 83	161	65	6.7	6.3	230.0	17.0	345	215
7 20 83	162	66	6.6	6.3	290.0	35.0	340	300
7 21 83	163	67	6.8	6.3	310.0	76.0	180	100
7 22 83	164	68	6.8	6.3	2100.0	87.0	130	400
7 23 83	165	69	7.0	6.2	2300.0	490.0		
7 24 83	166	70	7.0	6.2	2300.0	560.0	350	
7 25 83	167	71	7.0	6.1	2000.0	520.0	307	85
7 26 83	168	72	6.8	6.1	20500.0	475.0	325	75
7 27 83	169	73	6.8	6.1	12000.0	1300.0	485	95
7 28 83	170	74	6.8	6.1	6600.0	1450.0	205	25
7 29 83	171	75	6.8	6.1		850.0		100
8 1 83	174	1	6.9	6.1	34500.0		290	
8 2 83	175	2	7.1	6.3	24000.0	2800.0	365	580
8 3 83	176	3	7.1	6.2	37500.0	3700.0	320	20
8 4 83	177	4	7.2	6.2	25000.0	2900.0	370	125
8 5 83	178	5	7.1	6.1		3850.0		140
8 8 83	181	8	7.2	6.1	113500.0		1480	
8 9 83	182	9	7.2	6.1	129300.0	14600.0	1870	90
8 10 83	183	10	7.2	6.1	280000.0	39000.0	3760	400
8 11 83	184	11	7.2	6.1	110000.0	31500.0	1055	385
8 12 83	185	12	7.1	6.2		23500.0		465

THIS IS THE START OF PHASE III DATA FOR FILTER 5. THIS FILTER HAD LARGE SAND.

8 15 83	188	15	7.6	6.2	113000.0		1080	
8 16 83	189	16	7.8	6.5	73500.0	14000.0	1360	57
8 17 83	190	17	7.8	6.6	77000.0	5500.0	835	120
8 18 83	191	18	7.7	6.7		6400.0		410
8 22 83	195	22	8.7	7.2	65700.0		1085	
8 23 83	196	23	8.0	7.2	78000.0	10900.0	99	110
8 24 83	197	24	7.9	7.2	80500.0	11500.0	720	315
8 25 83	198	25	7.8	7.1		19000.0		115
8 29 83	202	29	8.0	7.3	70000.0		790	
8 30 83	203	30	7.9	7.3	70000.0	11200.0	990	95
9 1 83	204	31	8.1	7.1		10700.0		102
9 5 83	208	35	8.1	6.7	58000.0		1025	
9 6 83	209	36	8.1	6.7	75000.0	5250.0	795	70
9 7 83	210	37	8.0	6.7	80000.0	7250.0	790	145
9 26 83	229	56	7.6	5.7	123000.0		3140	
9 27 83	230	57	7.8	6.0	120000.0	2150.0	1225	150
9 28 83	231	58	7.5	6.2	70000.0	7350.0	1085	184
9 29 83	232	59	7.5	6.1		2650.0		300
9 30 83	233	60	7.4	6.1				
10 11 83	245	72	7.2	6.4	2.0		365	
10 12 83	246	73	7.2	6.4	4.0	0.0	584	277
10 13 83	247	74	7.4	6.4	0.0	.5	415	280
10 14 83	248	75	7.5	6.5	3.4	0.0	268	127
10 15 83	249	76	7.7	6.5	2.6	0.0	172	275
10 16 83	250	77	7.5	6.6	1.4	1.0	118	248
10 17 83	251	78	7.5	6.6	1.3	0.0	120	271
10 26 83	260	87	7.4	6.8	.7		96	
10 27 83	261	88	7.4	6.8	.7	.5	56	330
11 5 83	270	97	7.3	6.8	.6		9	

(CONTINUED)

Table B-5. (continued).

DATE		DAYS OF CONTINUOUS OPERATION (DAYS)	AGE OF SCHMIDTZECKE (DAYS)	INFLUENT TURBIDITY (NTU)	EFFLUENT TURBIDITY (NTU)	INFLUENT COLIFORM (NO/100ML)	EFFLUENT COLIFORM (NO/100ML)	INFLUENT STD PLATE COUNT (NO/ML)	EFFLUENT STD PLATE COUNT (NO/ML)	
11	6	83	271	98	7.2	6.8	.6	0.0	67	333
11	7	83	272	99	7.2	6.8	1540.0	0.0	418	223
11	8	83	273	100	7.1	6.9	1530.0	280.0	93	408
11	9	83	274	101	7.2	6.9	2350.0	305.0	62	298
11	10	83	275	102	7.3	6.9	1950.0	210.0	52	191
11	13	83	278	105	7.3	7.0			13	
11	14	83	279	106	7.4	7.0			13	373
11	15	83	280	107	7.8	7.0			8	251
11	16	83	281	108	8.1	7.1			7	272
11	17	83	282	109	7.8	7.0			7	382
11	18	83	283	110	7.7	7.1			7	363
11	19	83	284	111	7.6	6.9			5	289
11	20	83	285	112	7.7	6.8			4	305
11	21	83	286	113	7.8	6.8		173500		328
11	22	83	287	114	8.0	6.8		205000		405
11	23	83	288	115	8.0	6.9		630000		805
11	24	83	289	116	7.8	6.9		525000		885
11	25	83	290	117	6.7	6.5		130000		970
11	26	83	291	118	7.2	6.3		108000		700
11	27	83	292	119	6.8	6.1		1385000		370
11	28	83	293	120	7.0	5.9		1510000		795
11	29	83	294	121	7.3	5.7		1145000		3535
11	30	83	295	122	7.4	5.7		1310000		2785
12	1	83	296	123	7.4	5.7				2985
12	14	83	309	136	5.3	4.6	2300.0		115	
12	15	83	310	137	5.4	4.7	2350.0	85.0	102	143
12	16	83	311	138	5.4	4.7	2900.0	45.0	201	178
12	17	83	312	139	5.3	4.6	2450.0	133.0	121	201
12	18	83	313	140	5.4	4.7	2600.0	105.0	143	197
12	19	83	314	141	5.3	4.7	2250.0	120.0	90	144
12	20	83	315	142	5.2	4.7	2300.0	74.0	115	121
12	21	83	316	143	5.4	4.8	2500.0	86.0	87	113
12	22	83	317	144	5.4	4.8	2150.0	139.0	126	115
12	23	83	318	145	5.5	4.8		125.0		166

Table B-6. Phase II slow sand filter data for Filter No. 6, this filter was operated at 5°C.

DATE	DAYS OF CONTINUOUS OPERATION	AGE OF SCHMUTZDECKE (DAYS)	INFLUENT TURBIDITY (NTU)	EFFLUENT TURBIDITY (NTU)	INFLUENT COLIFORM (NO/100ML)	EFFLUENT COLIFORM (NO/100ML)	INFLUENT STD PLATE COUNT (NO/ML)	EFFLUENT STD PLATE COUNT (NO/ML)
MM DY YR	(DAYS)	(DAYS)	(NTU)	(NTU)	(NO/100ML)	(NO/100ML)	(NO/ML)	(NO/ML)
2 9 83	1	1	9.1	6.6				
2 10 83	2	2	9.1	8.0	2.0		240	330
2 11 83	3	3	8.9	8.3	51000.0	0.0	1310	670
2 12 83	4	4	9.0	8.3	7100.0	61500.0	755	1530
2 13 83	5	5	9.0	8.1	3400.0	2700.0	74	1115
2 14 83	6	6	8.7	8.0	4900.0	1290.0	985	1820
2 15 83	7	7	8.8	8.1	5000.0	1370.0	3620	2100
2 16 83	8	8	8.7	7.9	2250.0	1800.0	4000	2230
2 17 83	9	9	8.6	7.8				
2 20 83	12	12	8.6	8.0	20000.0		3850	
2 21 83	13	13	8.6	8.0	14667.0	3600.0	365	18300
2 22 83	14	14	8.5	7.7	21000.0	7450.0	630	5460
2 23 83	15	15	8.6	7.6	37500.0	6500.0	635	11250
2 24 83	16	16	8.3	7.5	20500.0	30000.0	9650	2960
2 25 83	17	17	8.4	7.5		4700.0		13700
2 27 83	19	19	8.3	8.3	1460.0		1015	
2 28 83	20	20	8.2	7.5	990.0	35.0	395	6450
3 1 83	21	21	8.0	7.4	6700.0	97.0	125	1200
3 2 83	22	22	7.8	7.4	2200.0	2250.0	330	7000
3 3 83	23	23	8.2	7.6	640.0	675.0	131	675
3 4 83	24	24	8.0	7.7		165.0		970
3 6 83	26	26	8.1		125.0		600	
3 7 83	27	27	7.4	7.8	48.0	8.0	44	2615
3 8 83	28	28	7.6	7.6	126.0	16.5	3045	112
3 9 83	29	29	7.5	7.6	42.5	23.5	135	110
3 10 83	30	30	7.6	7.6	2000.0	5.5	330	550
3 11 83	31	31	7.6	7.5		490.0		785
3 14 83	34	34	7.8	7.7	2650.0		415	
3 15 83	35	35	7.8	7.9	20000.0	500.0	945	680
3 16 83	36	36	7.4	8.2	22000.0	9000.0	975	810
3 17 83	37	37	7.4	8.0		9000.0		925
3 20 83	40	40	7.2	7.8	66000.0		595	
3 21 83	41	41	7.0	7.6	76500.0	29500.0	830	505
3 22 83	42	42	6.9	7.6	91500.0	34500.0	9950	630
3 23 83	43	43	6.8	7.7	61000.0	61000.0	700	620
3 24 83	44	44	6.7	7.7	66500.0	20000.0	775	280
3 25 83	45	45	6.7	7.1		32500.0		310
3 27 83	47	47	6.8	7.0	64000.0		850	
3 28 83	48	48	6.7	6.9	14000.0	2300.0	340	510
3 29 83	49	49	6.7	6.8		1700.0		315
4 5 83	56	56	7.3	6.4	3000.0		19200	
4 6 83	57	57	7.2	6.5	2200.0	345.0	1570	2400
4 7 83	58	58	7.0	6.2	1100.0	4.0	1790	4200
4 8 83	59	59	7.0	6.0		13.0		700
4 11 83	62	62	6.8	6.0	3950.0		690	
4 12 83	63	63	6.8	6.0	3000.0	440.0	775	15
4 13 83	64	64	6.8	6.1	6700.0	420.0	285	60
4 14 83	65	65	6.7	6.0		100.0		70
4 16 83	67	1						
4 21 83	72	6	6.6	6.3				
4 22 83	73	7	6.4	6.0				
4 25 83	76	10	7.7	6.4	145000.0		1555	
4 26 83	77	11	6.9	6.4	125000.0	2100.0	1375	45
4 27 83	78	12	6.5	6.2	215000.0	2000.0	2285	15
4 28 83	79	13	6.4	6.1		7100.0		33
5 3 83	84	18	6.7	5.9				
5 4 83	85	19	6.6	6.5				
5 15 83	96	30	6.3	5.7				
5 16 83	97	1	6.3	5.8	113000.0		1460	
5 17 83	98	2	6.3	5.8	70500.0	3400.0	755	90
5 18 83	99	3	6.2	5.9	72500.0	4100.0	840	55
5 19 83	100	4	6.2	5.9	70000.0	4250.0	965	95
5 20 83	101	5	6.1	5.8		5750.0		20
5 23 83	104	8	6.1	5.7	63000.0		1145	
5 24 83	105	9	6.0	5.7	69000.0	3200.0	820	65
5 25 83	106	10	6.1	5.8	69000.0	4300.0	390	55
5 26 83	107	11	6.1	5.7	56500.0	3550.0	670	65
5 27 83	108	12	6.0	5.8		3200.0		245
5 30 83	111	15	6.1	5.8	64000.0		680	
5 31 83	112	16	6.1	5.8	52500.0	990.0	710	35

(CONTINUED)

Table B-6. (continued).

DATE	DAYS OF CONTINUOUS OPERATION	AGE OF SCHMUTZDECKE (DAYS)	INFLUENT	EFFLUENT	INFLUENT	EFFLUENT	INFLUENT	EFFLUENT
			TURBIDITY (NTU)	TURBIDITY (NTU)	COLIFORM (NO/100ML)	COLIFORM (NO/100ML)	STD PLATE COUNT (NO/ML)	STD PLATE COUNT (NO/ML)
6 1 83	113	17	6.2	5.8	35500.0	4900.0	630	105
6 2 83	114	18	6.1	5.8		4850.0		35
6 27 83	139	43	8.9	7.6	35000.0		515	
6 28 83	140	44	7.8	7.0	38000.0	2800.0	660	210
6 29 83	141	45	7.4	6.6	49000.0	5000.0	655	95
6 30 83	142	46	7.3	6.5	33000.0	6900.0	420	15
7 1 83	143	47	7.3	6.5		6100.0		95
7 4 83	146	50	7.0	6.4	930.0		224	
7 5 83	147	51	7.0	6.4	2300.0	265.0	155	50
7 6 83	148	52	7.0	6.5	3200.0	590.0	150	15
7 7 83	149	53	7.0	6.5	4250.0	670.0	515	80
7 8 83	150	54	7.0	6.5		1170.0		45
7 11 83	153	57	7.1	6.3	35.0		3000	
7 12 83	154	58	7.1	6.3	66.0	39.0	280	40
7 13 83	155	59	6.9	6.3	76.0	17.0	190	75
7 14 83	156	60	6.8	6.3	74.0	21.0	160	15
7 15 83	157	61	6.8	6.3	31.0	15.0	490	90
7 18 83	160	64	6.8	6.3	340.0		320	
7 19 83	161	65	6.7	6.3	230.0	27.0	345	165
7 20 83	162	66	6.6	6.3	290.0	28.0	340	205
7 21 83	163	67	6.8	6.3	310.0	60.0	180	55
7 22 83	164	68	6.8	6.3	2100.0	68.0	130	145
7 23 83	165	69	7.0	6.2	2300.0	300.0		
7 24 83	166	70	7.0	6.1	2300.0	510.0	350	
7 25 83	167	71	7.0	6.1	2000.0	390.0	307	110
7 26 83	168	72	6.8	6.1	20500.0	365.0	325	80
7 27 83	169	73	6.8	6.1	12000.0	950.0	485	45
7 28 83	170	74	6.8	6.1	6600.0	1250.0	205	45
7 29 83	171	75	6.8	6.1		750.0		45
8 1 83	174	1	6.9	6.1	34500.0		290	
8 2 83	175	2	7.1	6.2	24000.0	2200.0	365	260
8 3 83	176	3	7.1	6.1	37500.0	1300.0	320	45
8 4 83	177	4	7.2	6.1	25000.0	1100.0	370	65
8 5 83	178	5	7.1	6.1		2250.0		85
8 8 83	181	8	7.2	6.1	113500.0		1480	
8 9 83	182	9	7.2	6.1	129300.0	4450.0	1870	110
8 10 83	183	10	7.2	6.1	280000.0	14500.0	3760	30
8 11 83	184	11	7.2	6.1	110000.0	17500.0	1055	65
8 12 83	185	12	7.1	6.2		13000.0		145

THIS IS THE START OF PHASE III DATA FOR FILTER 6, THIS FILTER WAS OPERATED AT 2°C.

8 15 83	188	15	7.6	6.2	113000.0		1080	
8 16 83	189	16	7.8	6.4	73500.0	4000.0	1360	60
8 17 83	190	17	7.8	6.4	77000.0	3050.0	835	50
8 18 83	191	18	7.7	6.3		4100.0		65
8 22 83	195	22	8.7	6.6	65700.0		1085	
8 23 83	196	23	8.0	6.6	78000.0	4000.0	99	50
8 24 83	197	24	7.9	6.5	80500.0	5300.0	720	45
8 25 83	198	25	7.8	6.5		5300.0		65
8 29 83	202	29	8.0	6.8	70000.0		790	
8 30 83	203	30	7.9	6.8	70000.0	6300.0	990	55
9 1 83	204	31	8.1	6.7		4550.0		65
9 5 83	208	35	8.1	7.7	98000.0		1025	
9 6 83	209	36	8.1	7.7	75000.0	2600.0	795	45
9 7 83	210	37	8.0	7.7	80000.0	3000.0	790	77
9 26 83	229	56	7.6	7.0	123000.0		3140	
9 27 83	230	57	7.8	7.1	120000.0	4450.0	1225	26
9 28 83	231	58	7.5	7.2	70000.0	7500.0	1085	60
9 29 83	232	59	7.5	7.2		3200.0		32
9 30 83	233	60	7.4	7.7				
10 11 83	245	72	7.2	6.6	2.0		365	
10 12 83	246	73	7.2	6.7	4.0	8.0	584	29
10 13 83	247	74	7.4	6.7	0.0	15.5	415	49
10 14 83	248	75	7.5	6.8	3.4	10.0	268	46
10 15 83	249	76	7.7	6.8	2.6	4.0	172	12
10 16 83	250	77	7.5	6.8	1.4	6.5	118	17
10 17 83	251	78	7.5	6.9	1.3	5.5	120	22
10 26 83	260	87	7.4	6.8	.7		96	
10 27 83	261	88	7.4	6.8	.7	2.0	56	20
11 5 83	270	97	7.3	6.7	.6		9	

(CONTINUED)



Table B-6. (continued).

DATE			DAYS OF CONTINUOUS OPERATION	AGE OF SCHMUTZDECKE (DAYS)	INFLUENT TURBIDITY (NTU)	EFFLUENT TURBIDITY (NTU)	INFLUENT COLIFORM (NO/100ML)	EFFLUENT COLIFORM (NO/100ML)	INFLUENT STD PLATE COUNT (NO/ML)	EFFLUENT STD PLATE COUNT (NO/ML)
11	6	83	271	98	7.2	6.7	.6	0.0	67	11
11	7	83	272	99	7.2	6.7	1540.0	0.0	418	6
11	8	83	273	100	7.1	6.7	1530.0	69.0	93	18
11	9	83	274	101	7.2	6.8	2350.0	145.0	62	10
11	10	83	275	102	7.3	6.8	1950.0	135.0	52	4
11	13	83	278	105	7.3	6.8			13	
11	14	83	279	106	7.4	6.8			13	19
11	15	83	280	107	7.8	6.8			8	13
11	16	83	281	108	8.1	6.6			7	17
11	17	83	282	109	7.8	6.7			7	18
11	18	83	283	110	7.7	6.6			7	17
11	19	83	284	111	7.6	6.6			5	19
11	20	83	285	112	7.7	6.7			4	20
11	21	83	286	113	7.8	6.6			173500	15
11	22	83	287	114	8.0	6.8			205000	50000
11	23	83	288	115	8.0	6.8			630000	21830
11	24	83	289	116	7.8	6.7			525000	66500
11	25	83	290	117	6.7	6.6			130000	32000
11	26	83	291	118	7.2	6.4			108000	69500
11	27	83	292	119	6.8	6.0			1385000	13550
11	28	83	293	120	7.0	5.9			1510000	94000
11	29	83	294	121	7.3	5.6			1145000	55000
11	30	83	295	122	7.4	5.6			1310000	84500
12	1	83	296	123	7.4	5.7				47500
12	14	83	309	136	5.3	3.7	2300.0		115	
12	15	83	310	137	5.4	4.1	2350.0	196.0	102	27
12	16	83	311	138	5.4	4.2	2900.0	148.0	201	52
12	17	83	312	139	5.3	4.2	2450.0	305.0	121	63
12	18	83	313	140	5.4	4.2	2600.0	213.0	143	43
12	19	83	314	141	5.3	4.3	2250.0	280.0	90	33
12	20	83	315	142	5.2	4.1	2300.0	165.0	115	26
12	21	83	316	143	5.4	4.2	2500.0	139.0	87	17
12	22	83	317	144	5.4	4.3	2150.0	210.0	126	23
12	23	83	318	145	5.5	4.2		238.0		43

## APPENDIX C

### Giardia Data for Slow Sand Filtration 2/1982 - 1/1983

Table C-1, C-2, and C-3 contain the results of Giardia cyst testing for the period February 1982 to January 1983. The same Giardia data shown in Table A-1, A-2, and A-3, Appendix A, are given here, as well as additional information such as the number of cysts in effluent corrected for the membrane recovery factors. The "detection limit" is the cyst concentration that is theoretically detectable, which is different for each test as it depends upon the volume of sample. Thus when cysts are not detected, i.e. 0 numerically, it is possible that the cysts were present, but it is not likely that the concentration could be greater than the detection limit. The "recovery factor" (also called "recovery efficiency") and the "detection limit" are described more fully in Appendix K.

Table C-1. Giardia Data for Slow Sand Filtration, Filter No. 1, v = 0.04 m/h (page 1 of 2)

Date (1982) Day Mo	Run Number	Temp. (°C)	Age of Schmutzdecke <sup>1</sup> (weeks)	Influent Cyst Concentration		Membrane Filter Recovery Factor <sup>4</sup> (%)	Effluent Volume Sampled (L)	Number of cysts in Effluent		Detection Limit <sup>7</sup> (c/L)	Giardia Analysis Method <sup>8</sup>
				Added <sup>2</sup> (c/L)	Detected <sup>3</sup> (c/L)			Detected <sup>5</sup> (No.)	Corrected <sup>6</sup> (No.)		
26	2	48	5	0	500	413	46.8	-	-	0.243	ZF
27	2	48	5		500	180		11	8	21.4	ZF
28	2	48	5		500	230		13	17	45.4	ZF
1	3	48	5		500	138		15	3	8.0	ZF
2	3	48	5		102	23		14	6	16.0	ZF
3	3	48	5	1	0	-	46.8 <sup>9/</sup>	12	15	40.1	ZF
18	3	54	15	3	500	1262	63.4 <sup>9/</sup>	-	-	-	ZF
19	3	54	15		500	665		14	0	0.0	ZF
20	3	54	15		500	656		17	0	0.0	ZF
21	3	54	15		500	1965		16	6	11.8	ZF
22	3	54	15		0	-		16	7	13.8	ZF
23	3	54	15	4	0	-	63.4	21	0	0.0	ZF
1	4	60	5	5	500	327	79.9	-	-	-	ZF
2	4	60	5		500	278		16	0	0.0	ZF
3	4	60	5		500	828		13	0	0.0	ZF
4	4	60	5		500	164		13	0	0.0	ZF
5	4	60	5		0	0		18	0	0.0	ZF
6	4	60	5	6	-	-	79.9	21	0	0.0	ZF
17	5	66	15	12	50	66.7	71.7	-	-	-	ZF
18	5	66	15		50	51.2		7	2	3.5	ZF
19	5	66	15		50	14.5		22	0	0.0	ZF
20	5	66	15		50	42.6		28	2	3.5	ZF
21	5	66	15		50	10.4		25	1	1.7	ZF
22	5	66	15		50	7.1		25	0	0.0	ZF
23	5	66	15		50	56.3 <sup>10/</sup>		28	0	0.0	ZF
24	5	66	15	13	50	0.6 <sup>10/</sup>	71.7	40	0	0.0	ZF
25	5	69	5	13	50	21.4	62.6	34	0	0.0	ZF
26	5	69	5		50	95.4		29	0	0.0	ZF
27	5	69	5		50	21.1		24	0	0.0	ZF
28	5	69	5		50	17.9		28	5	10.0	ZF
29	5	69	5	13	12.5	-	62.6	25	3	6.0	ZF
6	6	75	15	0	50	8.7	31.8	-	-	-	ZF
7	6	75	15		50	0.8		33	0	0.0	ZF
8	6	75	15		50	0.9		31	0	0.0	ZF
9	6	75	15		50	31.1		31	0	0.0	ZF
10	6	75	15		50	16.6		26	0	0.0	ZF
11	6	75	15		50	20.4		25	0	0.0	ZF
12	6	75	15		0	-		33	0	0.0	ZF
20	6	75	15		50	18.0		-	-	-	ZF
21	6	75	15		50	26.9		28	0	0.0	ZF
22	6	75	15		50	15.1		30	0	0.0	ZF
23	6	75	15		50	19.9		27	0	0.0	ZF
24	6	75	15		50	16.7		26	0	0.0	ZF
25	6	75	15	3	0	-	31.8	24	0	0.0	ZF
4	7	81	5	0	50	34.3	64.3	-	-	-	MF
5	7	81	5		50	56.0		28	0	0.0	MF
6	7	81	5		50	29.1		26	0	0.0	MF
7	7	81	5		50	26.7		24	0	0.0	MF
8	7	81	5		50	28.1		26	0	0.0	MF
9	7	81	5		50	-		27	0	0.0	MF
18	7	81	5		50	16.6		-	-	-	MF
19	7	81	5		50	30.0		24	0	0.0	MF
20	7	81	5		50	15.7		23	0	0.0	MF
21	7	81	5		50	13.6		22	0	0.0	MF
22	7	81	5		50	58.2		-	-	-	MF
23	7	81	5	3	50	45.6	64.3	144	0	0.0	MF
1	8	87	15	4	1000	123	18.4	-	-	-	MF
2	8	87	15		1000	173		29	0	0.0	MF
3	8	87	15		0	-		28	0	0.0	MF
4	8	87	15		1000	256		-	-	-	MF
5	8	87	15		1000	183		27	0	0.0	MF
6	8	87	15	5	0	-	18.4	27	0	0.0	MF
8	8	90	15	5	1000	167	22.1	-	-	-	MF
9	8	90	15		1000	220		23	0	0.0	MF
10	8	90	15		1000	160		29	0	0.0	MF
11	8	90	15		1000	256		27	0	0.0	MF
12	8	90	15	6	1000	300	22.1	78	0	0.0	MF

Table C-1. Giardia Data for Slow Sand Filtration, Filter No. 1, v = 0.04 m/h (page 2 of 2)

Date (1982) Day Mo	Run Number	Temp. (°C)	Age of Schmutzdecke <sup>1</sup> (weeks)	Influent Cyst Concentration		Membrane Filter Recovery Factor <sup>4</sup> (%)	Effluent Volume Sampled (L)	Number of cysts in Effluent		Detection Limit <sup>7</sup> (c/L)	Giardia Analysis Method <sup>8</sup>	
				Added <sup>2</sup> (c/L)	Detected <sup>3</sup> (c/L)			Detected <sup>5</sup> (No.)	Corrected <sup>6</sup> (No.)			
20	10	101	15	16	1000	720	78.5	-	-	-	MP	
21	10	101	15		1173	986		23	0	0.0	1.108	MP
22	10	101	15		0	-		38	0	0.0	0.944	MP
23	10	101	15		0	-		27	0	0.0	1.062	MP
24	10	101	15		0	-		24	0	0.0	1.062	MP
25	10	101	15	16	0	-	78.5	26	0	0.0	0.980	MP
26	10	104	15	16	5000	2060	53.3	-	-	-	-	MP
27	10	104	15		5150	3350		23	0	0.0	1.631	MP
28	10	104	15		0	-		36	0	0.0	1.042	MP
29	10	104	15		0	-		48	0	0.0	0.782	MP
30	10	104	15		0	-		32	0	0.0	1.173	MP
31	10	104	15	17	0	-	53.3	32	0	0.0	1.173	MP
3	11	107	15	0	1505	784	48.4	-	-	-	-	MP
4	11	107	15		1500	668		28	0	0.0	1.476	MP
5	11	107	15		0	-		45	0	0.0	0.918	MP
6	11	107	15		0	-		26	0	0.0	1.589	MP
7	11	107	15	1	0	-	48.4	43	0	0.0	0.961	MP
12	11	110	15	0	1982	1250	79.7	-	-	-	-	MP
13	11	110	15		1923	1863		26	0	0.0	0.965	MP
14	11	110	15		0	-		37	0	0.0	0.678	MP
15	11	110	15		0	-		75	0	0.0	0.335	MP
16	11	110	15	1	0	-	79.7	38	0	0.0	0.660	MP
7	12	116	15	0	3692	2433	94.0	-	-	-	-	MP
8	12	116	15		3692	4507		98	0	0.0	0.217	MP
9	12	116	15		0	-		138	0	0.0	0.154	MP
10	12	116	15		0	-		111	0	0.0	0.192	MP
11	12	116	15	1	0	-	94.0	150	0	0.0	0.142	MP
18	1	118	15	0	2000	2100	72.0	-	-	-	-	MP
19	1	118	15		2000	1458		127	1180	1639	0.219	MP
20	1	118	15		2000	1282		115	2060	2861	0.242	MP
21	1	118	15		2000	920		139	1920	2667	0.200	MP
22	1	118	15		0	-		127	1330	1847	0.219	MP
23	1	118	15	1	0	-	72.0	102	1000	1389	0.272	MP

<sup>1</sup> Age of schmutzdecke refers to the number of weeks which have passed since the last schmutzdecke removal.

<sup>2</sup> The influent cyst concentration 'added' is determined by performing multiple analyses of a cyst concentrate, i.e. liquified dog feces. This known concentration of cysts is diluted in a known volume of water in the filter feed tank, and the cyst concentration listed is corrected by this dilution factor.

<sup>3</sup> The influent cyst concentration 'detected' is determined by analyzing a subsample from the filter feed tank. The subsample is concentrated with a membrane filter.

<sup>4</sup> The membrane filter recovery factor is calculated by: (Influent Cysts Detected/Influent Cysts Added).

<sup>5</sup> The number of cysts detected in the effluent is the actual number of cysts counted in the effluent sample. This value has been corrected for any dilution factor which occurred during analysis.

<sup>6</sup> This value is the number of cysts detected in the effluent corrected for the membrane recovery factor and when the zinc floatation analysis method was used, an additional factor of 0.8 was incorporated in the calculation. These two correction factors are discussed in Appendix I.

The calculation is:  
 (Effluent cysts detected)/(Membrane recovery factor)  
 With zinc floatation analysis method:  
 (Effluent cysts detected)/[(Membrane recovery factor)(0.8)]

<sup>7</sup> Detection limits are discussed in Appendix I.

<sup>8</sup> Giardia analysis method:  
 ZF = Zinc Floatation  
 MP = Micropipette  
 These analysis methods are discussed in Appendix J.

<sup>9</sup> The membrane recovery factor could not be determined for this test run so an average of similar test runs was used.

<sup>10</sup> This value is used with test runs 68, 69 and 70 since it is used in calculations with the effluent value from the following day.

Table C-2. Giardia Data for Slow Sand Filtration, Filter No. 2, v = 0.12 m/h (page 1 of 2)

Date (19 <u>  </u> ) Day No	Run Number	Temp. (°C)	Age of Schmutzdecke <sup>1</sup> (weeks)	Influent Cyst Concentration		Membrane Filter Recovery Factor <sup>4</sup> (%)	Effluent Volume Sampled (L)	Number of cysts in Effluent		Detection Limit <sup>7</sup> (c/L)	Giardia Analysis Method <sup>8</sup>	
				Added <sup>2</sup> (c/L)	Detected <sup>3</sup> (c/L)			Detected <sup>5</sup> (No.)	Corrected <sup>6</sup> (No.)			
26	2	47	5	0	500	413	46.8	-	-	-	ZF	
27	2	47	5		500	180		33	25	66.8	0.081	ZF
28	2	47	5		500	230		36	33	88.1	0.074	ZF
1	3	47	5		500	138		42	14	37.4	0.064	ZF
2	3	47	5		102	28		37	5	13.4	0.072	ZF
3	3	47	5	1	0	-	46.8 <sup>9/</sup>	34	28	74.8	0.079	ZF
18	3	53	15	3	500	1262	63.4 <sup>9/</sup>	-	-	-	-	ZF
19	3	53	15		500	663		38	0	0.0	0.052	ZF
20	3	53	15		500	656		45	0	0.0	0.044	ZF
21	3	53	15		500	1963		42	16	31.5	0.047	ZF
22	3	53	15		0	-		44	0	0.0	0.045	ZF
23	3	53	15	4	0	-	63.4	56	0	0.0	0.035	ZF
1	4	59	5	5	500	327	79.9	-	-	-	-	ZF
2	4	59	5		500	278		46	5	7.8	0.034	ZF
3	4	59	5		500	828		35	0	0.0	0.045	ZF
4	4	59	5		500	164		34	0	0.0	0.046	ZF
5	4	59	5		0	0		48	0	0.0	0.033	ZF
6	4	59	5	6	0	-	79.9	57	0	0.0	0.027	ZF
17	5	65	15	12	50	66.7	71.7	-	-	-	-	ZF
18	5	65	15		50	53.2		15	0	0.0	0.116	ZF
19	5	65	15		50	14.3		54	0	0.0	0.032	ZF
20	5	65	15		50	42.6		70	2	3.5	0.025	ZF
21	5	65	15		50	10.4		66	0	0.0	0.026	ZF
22	5	65	15		50	7.1		60	0	0.0	0.029	ZF
23	5	65	15		50	56.3 <sup>10/</sup>		69	1	1.7	0.025	ZF
24	5	65	15	13	50	0.6 <sup>10/</sup>	71.7	95	1	1.7	0.018	ZF
25	5	68	5	13	50	21.4	62.6	79	3	6.0	0.025	ZF
26	5	68	5		50	95.4		71	2	4.0	0.028	ZF
27	5	68	5		50	21.1		62	0	0.0	0.032	ZF
28	5	68	5		50	17.9		70	0	0.0	0.029	ZF
29	5	68	5	13	12.5	-	62.6	63	2	4.0	0.032	ZF
6	6	74	15	0	50	8.7	31.8	-	-	-	-	ZF
7	6	74	15		50	0.8		79	0	0.0	0.050	ZF
8	6	74	15		50	0.9		79	0	0.0	0.050	ZF
9	6	74	15		50	31.1		74	0	0.0	0.053	ZF
10	6	74	15		50	16.6		71	0	0.0	0.055	ZF
11	6	74	15		50	20.4		65	0	0.0	0.060	ZF
12	6	74	15		50	-		84	0	0.0	0.047	ZF
20	6	74	15		50	18.0		-	-	-	-	ZF
21	6	74	15		50	26.9		70	0	0.0	0.056	ZF
22	6	74	15		50	15.1		79	0	0.0	0.050	ZF
23	6	74	15		50	19.9		69	0	0.0	0.057	ZF
24	6	74	15		50	16.7		71	0	0.0	0.055	ZF
25	6	74	15	3	0	-	31.8	62	0	0.0	0.063	ZF
4	7	80	5	0	50	34.3	64.3	-	-	-	-	MP
5	7	80	5		50	56.0		60	0	0.0	0.518	MP
6	7	80	5		50	29.1		75	0	0.0	0.415	MP
7	7	80	5		50	26.7		67	0	0.0	0.464	MP
8	7	80	5		50	28.1		72	0	0.0	0.432	MP
9	7	80	5		50	-		75	0	0.0	0.415	MP
18	7	80	5		50	16.6		-	-	-	-	MP
19	7	80	5		50	30.0		55	0	0.0	0.566	MP
20	7	80	5		50	15.7		60	0	0.0	0.518	MP
21	7	80	5		50	13.6		55	0	0.0	0.566	MP
22	7	80	5		50	58.2		-	-	-	-	MP
23	7	80	5	3	50	45.6	64.3	334	0	0.0	0.093	MP
1	8	86	15	4	1000	123	18.4	-	-	-	-	MP
2	8	86	15		1000	173		72	0	0.0	1.510	MP
3	8	86	15		0	-		71	0	0.0	1.531	MP
4	8	86	15		1000	256		-	-	-	-	MP
5	8	86	15		1000	183		68	0	0.0	1.598	MP
6	8	86	15	5	0	-	18.4	66	0	0.0	1.646	MP
8	8	89	15	5	1000	167	22.1	-	-	-	-	MP
9	8	89	15		1000	220		57	0	0.0	1.588	MP
10	8	89	15		1000	160		69	0	0.0	1.312	MP
11	8	89	15		1000	258		61	0	0.0	1.484	MP
12	8	89	15	6	1000	300	22.1	187	0	0.0	0.489	MP

Table C-2. Giardia Data for Slow Sand Filtration, Filter No. 2, v = 0.12 m/h (page 2 of 2)

Date (1982) Day No	Run Number	Temp. (°C)	Age of Schmutzdecke <sup>1</sup> (weeks)	Influent Cyst Concentration		Membrane Filter Recovery	Effluent Volume Sampled (L)	Number of cysts in Effluent		Detection Limit <sup>7</sup> (c/L)	Giardia Analysis Method <sup>8</sup>
				Added <sup>2</sup> (c/L)	Detected <sup>3</sup> (c/L)	Factor <sup>4</sup> (%)		Detected <sup>5</sup> (No.)	Corrected <sup>6</sup> (No.)		
20	10	102	15	16	1000	720	78.5	-	-	-	MP
21	10	102	15		1173	986		51	0	0.0	MP
22	10	102	15		0	-		87	0	0.0	MP
23	10	102	15		0	-		70	0	0.0	MP
24	10	102	15		0	-		66	0	0.0	MP
25	10	102	15	16	0	-	78.5	68	0	0.0	MP
26	10	105	15	16	5000	2060	53.3	-	-	-	MP
27	10	105	15		5150	3350		60	0	0.0	MP
28	10	105	15		0	-		95	0	0.0	MP
29	10	105	15		0	-		121	0	0.0	MP
30	10	105	15		0	-		79	0	0.0	MP
31	10	105	15	17	0	-	53.3	80	0	0.0	MP
3	11	108	15	0	1505	784	48.4	-	-	-	MP
4	11	108	15		1500	668		71	0	0.0	MP
5	11	108	15		0	-		113	0	0.0	MP
6	11	108	15		0	-		63	0	0.0	MP
7	11	108	15	1	0	-	48.4	107	0	0.0	MP
12	11	111	15	0	1982	1250	79.7	-	-	-	MP
13	11	111	15		1923	1863		67	0	0.0	MP
14	11	111	15		0	-		96	0	0.0	MP
15	11	111	15		0	-		192	0	0.0	MP
16	11	111	15	1	0	-	79.7	99	0	0.0	MP
18	1	119	15	10	2000	2100	72.0	-	-	-	MP
19	1	119	15		2000	1458		193	0	0.0	MP
20	1	119	15		2000	1282		139	0	0.0	MP
21	1	119	15		2000	920		154	0	0.0	MP
22	1	119	15		0	-		166	0	0.0	MP
23	1	119	15	11	0	-	72.0	173	0	0.0	MP

<sup>1</sup> Age of schmutzdecke refers to the number of weeks which have passed since the last schmutzdecke removal.

<sup>2</sup> The influent cyst concentration 'added' is determined by performing multiple analyses of a cyst concentrate, i.e. liquified dog feces. This known concentration of cysts is diluted in a known volume of water in the filter feed tank, and the cyst concentration listed is corrected by this dilution factor.

<sup>3</sup> The influent cyst concentration 'detected' is determined by analyzing a subsample from the filter feed tank. The subsample is concentrated with a membrane filter.

<sup>4</sup> The membrane filter recovery factor is calculated by: (Influent Cysts Detected/Influent Cysts Added).

<sup>5</sup> The number of cysts detected in the effluent is the actual number of cysts counted in the effluent sample. This value has been corrected for any dilution factor which occurred during analysis.

<sup>6</sup> This value is the number of cysts detected in the effluent corrected for the membrane recovery factor and when the zinc floatation analysis method was used, an additional factor of 0.8 was incorporated in the calculation. These two correction factors are discussed in Appendix I.

The calculation is:

(Effluent cysts detected)/(Membrane recovery factor)

With zinc floatation analysis method:

(Effluent cysts detected)/[(Membrane recovery factor)(0.8)]

<sup>7</sup> Detection limits are discussed in Appendix I.

<sup>8</sup> Giardia analysis method:

ZF = Zinc Floatation

MP = Micropipette

These analysis methods are discussed in Appendix J.

<sup>9</sup> The membrane recovery factor could not be determined for this test run so an average of similar test runs was used.

<sup>10</sup> This value is used with test runs 68, 69 and 70 since it is used in calculations with the effluent value from the following day.

Table C-3. Giardia Data for Slow Sand Filtration, Filter No. 3, v = 0.40 m/h (page 1 of 2)

Date (1982) Day Mo	Run Number	Temp. (°C)	Age of Schmutzdecke <sup>1</sup> (weeks)	Influent Cyst Concentration		Membrane Filter Recovery Factor <sup>4</sup> (%)	Effluent Volume Sampled (L)	Number of cysts in Effluent		Detection Limit <sup>7</sup> (c/L)	Giardia Analysis Method <sup>8</sup>	
				Added <sup>2</sup> (c/L)	Detected <sup>3</sup> (c/L)			Detected <sup>5</sup> (No.)	Corrected <sup>6</sup> (No.)			
26	2	49	5	0	500	413	46.8	-	-	-	ZF	
27	2	49	5		500	180		28	31	82.8	0.095	ZF
28	2	49	5		500	230		48	24	64.1	0.056	ZF
1	3	49	5		500	138		76	176	470.1	0.035	ZF
2	3	49	5		102	23		69	251	670.4	0.039	ZF
3	3	49	5	1	0	-	46.8 <sup>9/</sup>	49	67	179.0	0.055	ZF
18	3	55	15	3	500	1262	63.4 <sup>9/</sup>	-	-	-	-	ZF
19	3	55	15		500	665		69	16	31.5	0.029	ZF
20	3	55	15		500	656		62	15	29.6	0.032	ZF
21	3	55	15		500	1965		68	21	41.4	0.029	ZF
22	3	55	15		0	-		77	6	11.8	0.026	ZF
23	3	55	15	4	0	-	63.4	70	10	19.7	0.028	ZF
1	4	61	5	5	500	327	79.9	-	-	-	-	ZF
2	4	61	5		500	178		61	23	36.0	0.026	ZF
3	4	61	5		500	828		74	0	0.0	0.021	ZF
4	4	61	5		500	164		68	2	3.1	0.023	ZF
5	4	61	5		0	0		84	1	1.6	0.019	ZF
6	4	61	5	6	0	-	79.9	79	0	0.0	0.020	ZF
17	5	67	15	2	50	66.7	71.7	-	-	-	-	ZF
18	5	67	15		50	53.2		64	0	0.0	0.027	ZF
19	5	67	15		50	14.5		79	0	0.0	0.022	ZF
20	5	67	15		50	42.6		149	0	0.0	0.012	ZF
21	5	67	15		50	10.4		131	0	0.0	0.013	ZF
22	5	67	15		50	7.1		167	0	0.0	0.010	ZF
23	5	67	15		50	56.3		216	1	1.7	0.008	ZF
24	5	67	15	3	50	0.6 <sup>10/</sup>	71.7	292	6	10.5	0.006	ZF
25	5	70	5	3	50	21.4	62.6	245	2	4.0	0.008	ZF
26	5	70	5		50	95.4		184	3	6.0	0.011	ZF
27	5	70	5		50	21.1		148	3	6.0	0.013	ZF
28	5	70	5		50	17.9		172	0	0.0	0.012	ZF
29	5	70	5	4	12.5	-	62.6	213	0	0.0	0.009	ZF
6	6	76	15	0	50	8.7	31.8	-	-	-	-	ZF
7	6	76	15		50	0.8		241	0	0.0	0.016	ZF
8	6	76	15		50	0.9		218	0	0.0	0.018	ZF
9	6	76	15		50	31.1		230	0	0.0	0.017	ZF
10	6	76	15		50	16.6		172	0	0.0	0.023	ZF
11	6	76	15		50	20.4		141	0	0.0	0.028	ZF
12	6	76	15		50	-		179	0	0.0	0.022	ZF
20	6	76	15		50	18.0		-	-	-	-	ZF
21	6	76	15		50	26.9		229	1	3.9	0.017	ZF
22	6	76	15		50	15.1		253	0	0.0	0.016	ZF
23	6	76	15		50	19.9		228	0	0.0	0.017	ZF
24	6	76	15		50	16.7		149	0	0.0	0.026	ZF
25	6	76	15	3	0	-	31.8	199	0	0.0	0.020	ZF
4	7	82	5	0	50	34.3	64.3	-	-	-	-	MP
5	7	82	5		50	56.0		229	0	0.0	0.136	MP
6	7	82	5		50	29.1		225	0	0.0	0.138	MP
7	7	82	5		50	26.7		202	0	0.0	0.154	MP
8	7	82	5		50	28.1		227	0	0.0	0.137	MP
9	7	82	5		50	-		228	0	0.0	0.136	MP
18	7	82	5		50	16.6		-	-	-	-	MP
19	7	82	5		50	30.0		209	0	0.0	0.149	MP
20	7	82	5		50	15.7		200	0	0.0	0.156	MP
21	7	82	5		50	13.6		189	0	0.0	0.165	MP
22	7	82	5		50	58.2		-	-	-	-	MP
23	7	82	5	3	50	45.6	64.3	962	0	0.0	0.032	MP
1	8	88	15	4	1000	123	18.4	-	-	-	-	MP
2	8	88	15		1000	173		237	0	0.0	0.459	MP
3	8	88	15		0	-		232	80	435	0.469	MP
4	8	88	15		1000	256		-	-	-	-	MP
5	8	88	15		1000	183		182	40	217	0.597	MP
6	8	88	15	5	0	-	18.4	220	100	543	0.494	MP
8	8	91	15	5	1000	167	22.1	-	-	-	-	MP
9	8	91	15		1000	220		191	0	0.0	0.474	MP
10	8	91	15		1000	160		233	0	0.0	0.388	MP
11	8	91	15		1000	258		223	0	0.0	0.406	MP
12	8	91	15	6	1000	300	22.1	196	0	0.0	0.462	MP

Table C-3. Giardia Data for Slow Sand Filtration, Filter No. 3, v = 0.40 m/h (page 2 of 2)

Date (1982) Day Mo	Run Number	Temp. (°C)	Age of Schmutzdecke <sup>1</sup> (weeks)	Influent Cyst Concentration		Membrane Filter Recovery Factor <sup>4</sup> (%)	Effluent Volume Sampled (L)	Number of cysts in Effluent		Detection Limit <sup>7</sup> (c/L)	Giardia Analysis Method <sup>8</sup>	
				Added <sup>2</sup> (c/L)	Detected <sup>3</sup> (c/L)			Detected <sup>5</sup> (No.)	Corrected <sup>6</sup> (No.)			
20	10	103	15	1000	720	78.5	-	-	-	-	MP	
21	10	103	15	1173	986		183	0	0.0	0.139	MP	
22	10	103	15	0	-		315	0	0.0	0.081	MP	
23	10	103	15	0	-		216	0	0.0	0.178	MP	
24	10	103	15	0	-		203	0	0.0	0.126	MP	
25	10	103	15	16	0	78.5	217	0	0.0	0.117	MP	
26	10	106	15	16	5000	2060	-	-	-	-	MP	
27	10	106	15		5150	3350	193	0	0.0	0.194	MP	
28	10	106	15		0	-	309	0	0.0	0.121	MP	
29	10	106	15		0	-	401	0	0.0	0.094	MP	
30	10	106	15		0	-	268	0	0.0	0.140	MP	
31	10	106	15	17	0	-	269	0	0.0	0.140	MP	
3	11	109	15	0	1505	784	48.4	-	-	-	MP	
4	11	109	15		1500	668		240	0	0.0	0.172	MP
5	11	109	15		0	-	382	0	0.0	0.108	MP	
6	11	109	15		0	-	215	0	0.0	0.192	MP	
7	11	109	15	1	0	-	362	0	0.0	0.114	MP	
12	11	112	15	0	1982	1250	79.7	-	-	-	MP	
13	11	112	15		1923	1863		193	0	0.0	0.130	MP
14	11	112	15		0	-	314	0	0.0	0.080	MP	
15	11	112	15		0	-	189	0	0.0	0.133	MP	
16	11	112	15	1	0	-	324	0	0.0	0.077	MP	
7	12	117	15	4	3692	2433	94.0	-	-	-	MP	
8	12	117	15		3692	4507		102	0	0.0	0.208	MP
9	12	117	15		0	-	194	0	0.0	0.110	MP	
10	12	117	15		0	-	112	0	0.0	0.190	MP	
11	12	117	15	5	0	-	157	0	0.0	0.136	MP	

- <sup>1</sup> Age of schmutzdecke refers to the number of weeks which have passed since the last schmutzdecke removal.
- <sup>2</sup> The influent cyst concentration 'added' is determined by performing multiple analyses of a cyst concentrate, i.e. liquified dog feces. This known concentration of cysts is diluted in a known volume of water in the filter feed tank, and the cyst concentration listed is corrected by this dilution factor.
- <sup>3</sup> The influent cyst concentration 'detected' is determined by analyzing a subsample from the filter feed tank. The subsample is concentrated with a membrane filter.
- <sup>4</sup> The membrane filter recovery factor is calculated by: (Influent Cysts Detected/Influent Cysts Added).
- <sup>5</sup> The number of cysts detected in the effluent is the actual number of cysts counted in the effluent sample. This value has been corrected for any dilution factor which occurred during analysis.
- <sup>6</sup> This value is the number of cysts detected in the effluent corrected for the membrane recovery factor and when the zinc floatation analysis method was used, an additional factor of 0.8 was incorporated in the calculation. These two correction factors are discussed in Appendix I.  
The calculation is:  
(Effluent cysts detected)/(Membrane recovery factor)  
With zinc floatation analysis method:  
(Effluent cysts detected)/[(Membrane recovery factor)(0.8)]
- <sup>7</sup> Detection limits are discussed in Appendix I.
- <sup>8</sup> Giardia analysis method:  
ZF = Zinc Floatation  
MP = Micropipette  
These analysis methods are discussed in Appendix J.
- <sup>9</sup> The membrane recovery factor could not be determined for this test run so an average of similar test runs was used.
- <sup>10</sup> This value is used with test runs 68, 69 and 70 since it is used in calculations with the effluent value from the following day.



## APPENDIX D

### Total Coliform Data for Slow Sand Filtration

Tables D-1, D-3, and D-5 contain the results of total coliform testing for Phase I, Phase II and Phase III testing. These tables show the influent and effluent total coliform data, as in Appendix A and Appendix B, as well as daily removal percentages. These removals have been calculated using the influent value from the previous day to account for residence time in the filter.

Tables D-2, D-4, and D-6 are statistical summaries of the total coliform data. These contain the total number of samples analyzed, the average influent and effluent coliform concentrations and the average removal percentage achieved by each filter. These calculations were performed first for all data available and again including only days having data for all three filters, allowing comparison between filters.

Table D-1. Total Coliform Data for Slow Sand Filtration, 7/1981 - 1/1983 (page 1 of 2)

DY	MO	YR	TEMP (°C)	FILTER NO.1 (0.04 m/h)			FILTER NO.2 (0.12 m/h)			FILTER NO.3 (0.40 m/h)										
				INFLUENT COLIFORM (NO/100ML)	SCHMUTZ- DECKE AGE (WEEKS)	EFFLUENT COLIFORM (NO/100ML)	PERCENT REMOVAL (%)	SCHMUTZ- DECKE AGE (WEEKS)	EFFLUENT COLIFORM (NO/100ML)	PERCENT REMOVAL (%)	SCHMUTZ- DECKE AGE (WEEKS)	EFFLUENT COLIFORM (NO/100ML)	PERCENT REMOVAL (%)							
26	7	81	5	770000.0				4	100000.0											
28	7	81	15					4	20000.0											
13	8	81	5	80000.0				6	0.0											
14	8	81	5	47000.0				6	3000.0		96.25									
15	8	81	15	9300.0				7	800.0		98.30									
17	8	81	15					7	220.0											
20	8	81	15	3.0				7	0.0											
3	9	81	15	92000.0									1	19000.0						
4	9	81	15	75000.0	1	1500.0	98.37						1	1700.0						98.15
5	9	81	15		1	3100.0	95.87						1	1400.0						98.13
25	9	81	15	28900.0																
26	9	81	15	100000.0	4	6.0	99.98	13	0.0	100.00		4	0.0	100.00						
3	10	81	5	80.0																
4	10	81	5	390.0	6	0.0	100.00	14	4.0	95.00										
5	10	81	5	290.0	6	5.0	98.72	14	10.0	97.44										
6	10	81	5	70.0	6	0.0	100.00	14	0.0	100.00										
7	10	81	5		6	0.0	100.00	14	3.0	95.71										
20	5	82	15																	
21	5	82	15		12	0.0		12	0.0			2	0.0							
22	5	82	15	5.0	12	0.0		12	0.0			3	0.0							
23	5	82	15	10.0	12	0.0	100.00	12	0.0	100.00		3	0.0							100.00
24	5	82	15	14.0	13	0.0	100.00	13	0.0	100.00		3	0.0							100.00
25	5	82	5	49.0	13	0.0	100.00	13	0.0	100.00		3	0.0							100.00
26	5	82	5	26.0	13	0.0	100.00	13	0.0	100.00		3	2.5							94.90
27	5	82	5	52.0	13	0.0	100.00	13	.5	98.08		3	1.5							94.23
28	5	82	5	48.0	13	.5	99.04	13	2.0	96.15		3	8.0							84.62
29	5	82	5		13	0.0	100.00	13	.5	98.96		4	3.0							93.75
8	6	82	15	3100.0	0	0.0		0	6.0			0	49.0							
9	6	82	15	2800.0	1	0.0	100.00	1	1.0	99.97		1	17.0							99.45
10	6	82	15	1480.0	1	2.0	99.93	1	2.0	99.93		1	11.0							99.61
11	6	82	15	1140.0	1	0.0	100.00	1	4.0	99.73		1	5.0							99.66
12	6	82	15		1	0.0	100.00	1	0.0	100.00		1	8.0							99.30
17	6	82	15	260.0	2	0.0		2	2.0			2	1.0							
18	6	82	15	262.0	2	0.0	100.00	2	6.0	97.69		2	3.0							98.85
20	6	82	15	490.0																
21	6	82	15	720.0	2	0.0	100.00	2	3.0	99.39		2	4.0							99.18
22	6	82	15	550.0	2	0.0	100.00	2	0.0	100.00		2	0.0							100.00
23	6	82	15	237.0	3	0.0	100.00	3	1.0	99.82		3	1.0							99.82
24	6	82	15	393.0	3	0.0	100.00	3	0.0	100.00		3	2.0							99.16
25	6	82	15		3	0.0	100.00	3	1.0	99.75		3	0.0							100.00
28	6	82	15	145.0																
29	6	82	15	153.0	3	0.0	100.00	3	.5	99.66		3	2.0							98.62
30	6	82	15	148.0	4	0.0	100.00	4	1.5	99.03		4	3.5							97.74
1	7	82	15	20.0	4	0.0	100.00	4	2.0	98.65		4	2.0							98.65
2	7	82	15	11.0	4	0.0	100.00	4	0.0	100.00		4	2.0							90.00
4	7	82	5	100.0																
5	7	82	5	67.0	0	0.0	100.00	0	1.0	99.00		0	3.0							97.00
6	7	82	5	71.0	0	0.0	100.00	0	0.0	100.00		0	0.0							100.00
7	7	82	5	31.0	1	0.0	100.00	1	0.0	100.00		1	1.5							97.89
8	7	82	5	37.0	1	0.0	100.00	1	0.0	100.00		1	.5							98.39
9	7	82	5	10.0	1	0.0	100.00	1	0.0	100.00		1	0.0							100.00
18	7	82	5	23.0																
19	7	82	5	18.0	2	0.0	100.00	2	0.0	100.00		2	0.0							100.00
20	7	82	5	17.0	2	0.0	100.00	2	0.0	100.00		2	2.0							88.89
21	7	82	5	20.0	3	0.0	100.00	3	1.0	94.12		3	0.0							100.00
22	7	82	5	20.0	3	1.0	95.00	3	1.0	95.00		3	1.0							95.00
26	7	82	15	4400.0	3	0.0		3	4.0			3	150.0							
27	7	82	15	600.0	3	0.0	100.00	3	11.0	99.75		3	300.0							93.18
28	7	82	15	700.0	4	0.0	100.00	4	6.0	99.00		4	135.0							77.50
29	7	82	15	4300.0	4	2.0	99.71	4	7.0	99.00		4	305.0							56.43
30	7	82	15	650.0	4	0.0	100.00	4	6.0	99.86		4	125.0							97.09
1	8	82	15	74000.0																
2	8	82	15	71000.0	4	1.0	100.00	4	143.0	99.81		4	2420.0							96.73
3	8	82	15		4	0.0	100.00	4	90.0	99.87		4	1200.0							98.31
4	8	82	15	290000.0																
5	8	82	15	210000.0	5	0.0	100.00	5	10.0	100.00		5	260.0							99.91
6	8	82	15		5	1.0	100.00	5	4.0	100.00		5	0.0							100.00
8	8	82	15	22000.0																

NOTE: 1) REMOVALS ARE CALCULATED WITH THE INFLUENT VALUE FROM THE PREVIOUS DAY TO ACCOUNT FOR RESIDENCE TIME IN THE FILTER  
2) NEGATIVE REMOVALS OCCUR WHEN THE EFFLUENT VALUE IS REFLECTIVE OF AN INFLUENT LOADING TWO OR MORE DAYS PRIOR

Table D-1. Total Coliform Data for Slow Sand Filtration,  
7/1981 - 1/1983 (page 2 of 2)

BY MO YR	TEMP (°C)	FILTER NO.1 (0.04 m/h)			FILTER NO.2 (0.12 m/h)			FILTER NO.3 (0.40 m/h)			
		INFLUENT COLIFORM (NO/100ML)	SCHMUTZ- DECKE AGE (WEEKS)	EFFLUENT COLIFORM (NO/100ML)	PERCENT REMOVAL (%)	SCHMUTZ- DECKE AGE (WEEKS)	EFFLUENT COLIFORM (NO/100ML)	PERCENT REMOVAL (%)	SCHMUTZ- DECKE AGE (WEEKS)	EFFLUENT COLIFORM (NO/100ML)	PERCENT REMOVAL (%)
9 8 82	15	13000.0	5	0.0	100.00	5	1.0	100.00	5	111.0	99.50
10 8 82	15	13800.0	5	8.0	99.94	5	2.0	99.98	5	76.0	99.42
11 8 82	15	18000.0	6	5.0	99.96	6	6.0	99.96	6	71.0	99.49
12 8 82	15	17000.0	6	2.0	99.99	6	1.0	99.99	6	59.0	99.67
13 8 82	15		6	1.0	99.99	6	1.0	99.99	6	86.0	99.49
16 8 82	15	2050.0									
17 8 82	15	1600.0	6	4.0	99.80	6	0.0	100.00	6	72.0	96.49
18 8 82	15	75.0	7	4.0	99.75	7	0.0	100.00	7	82.0	94.88
28 9 82	15	21000.0									
29 9 82	15	24000.0	13	4.0	99.98				13	114.0	99.46
30 9 82	15	32000.0	13	5.5	99.98				13	185.0	99.23
1 10 82	15	7000.0	13	7.0		13	275.0	98.85	13	140.0	
2 10 82	15	4400.0	13	10.0	99.86	13	107.0	98.47	13	120.0	98.29
3 10 82	15	6000.0	13	4.5	99.90	13	170.0	96.14	13	80.0	98.18
4 10 82	15	21000.0	13	4.0	99.93	13	85.0	98.58	13	63.0	98.95
5 10 82	15	26500.0	13	3.5	99.98	13	110.0	99.48	13	125.0	99.40
6 10 82	15	20000.0	14	.5	100.00	14	40.5	99.85	14	61.0	99.77
7 10 82	15	500.0	14	.5	100.00	14	33.0	99.84	14	31.0	99.85
8 10 82	15	145.0	14	0.0	100.00	14	8.5	98.30	14	20.0	96.00
9 10 82	15		14	.5	99.66	14	6.0	95.86	14	7.0	95.17
11 10 82	15	47500.0									
12 10 82	15	1150.0	14	0.0	100.00	14	22.0	99.95	14	37.0	99.92
15 10 82	15	700.0	15	.5		15	7.5		15	19.5	
16 10 82	15		15	0.0	100.00				15	9.5	98.64
20 10 82	15	600.0									
21 10 82	15	13000.0	16	0.0	100.00	16	3.5	99.42	16	5.0	99.17
22 10 82	15	2.5	16	1.5	99.99	16	17.0	99.87	16	28.0	99.78
23 10 82	15	3.5	16	.5	80.00	16	5.0	-100.00	16	11.0	-360.00
24 10 82	15	.5	16	0.0	100.00	16	3.0	14.29	16	5.5	-57.14
25 10 82	15	2.0	16	0.0	100.00	16	1.5	-200.00	16	3.0	-500.00
26 10 82	15	23500.0	16	0.0	100.00	16	1.0	50.00	16	2.0	0.00
27 10 82	15	22500.0	17	.5	100.00	17	30.0	99.87	17	101.0	99.57
28 10 82	15	1.0	17	1.5	99.99	17	18.0	99.92	17	76.0	99.66
29 10 82	15	1.0	17	0.0	100.00	17	3.5	-250.00	17	7.0	-600.00
30 10 82	15	3.0	17	0.0	100.00	17	.5	50.00	17	2.5	-150.00
31 10 82	15	2.0	17	0.0	100.00	17	0.0	100.00	17	3.5	-16.67
1 11 82	15	2.0	17	.5	75.00	17	0.0	100.00	17	1.0	50.00
2 11 82	15	3.0	18	0.0	100.00	18	0.0	100.00	18	1.0	50.00
3 11 82	15	20000.0	0	0.0	100.00	0	0.0	100.00	0	1.5	50.00
4 11 82	15	24000.0	0	6.0	99.97	0	195.0	99.02	0	680.0	96.60
5 11 82	15	2.5	0	7.0	99.97	0	235.0	99.02	0	560.0	97.67
6 11 82	15	0.0	1	1.0	60.00	1	22.0	-780.00	1	152.0	-5980.00
7 11 82	15	0.0	1	.5		1	13.0		1	79.0	
8 11 82	15	.5	1	.5		1	6.0		1	51.0	
9 11 82	15	1.0	1	0.0	100.00	1	7.0	-1300.00	1	29.5	-5800.00
12 11 82	15	20500.0									
13 11 82	15	15500.0	0	235.0	98.85	0	1118.0	94.55	0	1350.0	93.41
14 11 82	15	5.5	0	110.0	99.29	0	570.0	96.32	0	880.0	94.32
15 11 82	15	1.0	1	26.0	-372.70	1	57.0	-936.30	1	175.0	-3081.00
16 11 82	15	.5	1	7.0	-600.00	1	34.0	-3300.00	1	105.0	-10400.00
17 11 82	15	0.0	1	2.5	-400.00	1	11.5	-2200.00	1	65.0	-12900.00
18 11 82	15	0.0	1	.5		1	11.0		1	28.0	
19 11 82	15	0.0	1	1.5		1	3.5		1	12.0	
7 12 82	15	29500.0									
8 12 82	15	24000.0	0	2050.0	93.05				4	0.0	100.00
9 12 82	15	1270.0	0	1700.0	92.92				4	0.0	100.00
10 12 82	15	960.0	1	180.0	85.83				4	2.0	99.84
11 12 82	15	230.0	1	120.0	87.50				4	0.0	100.00
12 12 82	15	.5	1	40.0	82.61				4	.5	99.78
13 12 82	15	0.0	1	4.5	-800.00				4	0.0	100.00
14 12 82	15	0.0	1	1.5					5	0.0	
18 1 83	15	39000.0									
19 1 83	15	42000.0	0	9500.0	75.64	10	670.0	98.28			
20 1 83	15	52500.0	0	6300.0	85.00	10	895.0	97.87			
21 1 83	15	39000.0	1	6500.0	87.62	10	870.0	98.34			
22 1 83	15	930.0	1	4200.0	89.23	10	630.0	98.38			
23 1 83	15	180.0	1	1100.0	-18.28	10	120.0	87.10			
24 1 83	15	0.0	1	210.0	-16.67	11	72.0	50.00			
26 1 83	15	0.0	1	20.5		11	14.0				

NOTE: 1) REMOVALS ARE CALCULATED WITH THE INFLUENT VALUE FROM THE PREVIOUS DAY TO ACCOUNT FOR RESIDENCE TIME IN THE FILTER  
2) NEGATIVE REMOVALS OCCUR WHEN THE EFFLUENT VALUE IS REFLECTIVE OF AN INFLUENT LOADING TWO OR MORE DAYS PRIOR

Table D-2. Statistical summary of total coliform data in Table D-1.

	Filter 1 (0.04m/hr)	Filter 2 (0.12m/hr)	Filter 3 (0.40m/hr)
All Available Data	99	91	91
	502.7	464.6	433.2
	4.0	7.15	14.2
	99.21	98.46	96.72
Calculations include only days having data for all three filters	81	81	81
	345.7	345.7	345.7
	1.7	4.8	14.9
	99.51	98.62	95.68

Table D-3. Total coliform data for Phase II slow sand filtration testing.

DATE MN DY YR	DAYS OF CONTINUOUS OPERATION (DAYS)	FILTER 1 (CONTR.)			FILTER 2 (1/2 SAND BED)			FILTER 3 (CHLORINATED)			FILTER 4 (NUTRIENTS ADDED)			FILTER 5 (5°C, LARGE SAND)			FILTER 6 (15°C)		
		INFLUENT COLIFORM CONC. (ND/100ML)	EFFLUENT COLIFORM CONC. (ND/100ML)	REMOVAL (%)	EFFLUENT COLIFORM CONC. (ND/100ML)	REMOVAL (%)	EFFLUENT COLIFORM CONC. (ND/100ML)	REMOVAL (%)	EFFLUENT COLIFORM CONC. (ND/100ML)	REMOVAL (%)	EFFLUENT COLIFORM CONC. (ND/100ML)	REMOVAL (%)	EFFLUENT COLIFORM CONC. (ND/100ML)	REMOVAL (%)	EFFLUENT COLIFORM CONC. (ND/100ML)	REMOVAL (%)	EFFLUENT COLIFORM CONC. (ND/100ML)	REMOVAL (%)	
2 9 83	1	2.0	100.00	100.00	0.0	0.0	100.00	0.0	0.0	100.00	0.0	0.0	100.00	0.0	0.0	100.00	0.0	100.00	
2 10 83	2	51000.0	-1.96	-8.82	52000.0	55500.0	30.28	52000.0	30.28	39000.0	45.07	79000.0	21.13	61500.0	21.13	61500.0	21.13	61500.0	
2 11 83	3	7100.0	25.35	8.22	5300.0	4950.0	75.15	4950.0	75.15	10300.0	30.88	5600.0	97.06	2700.0	97.06	2700.0	97.06	2700.0	
2 12 83	4	3400.0	95.59	75.15	150.0	845.0	92.65	845.0	92.65	2350.0	73.00	1195.0	53.00	1370.0	53.00	1370.0	53.00	1370.0	
2 13 83	5	4900.0	92.04	91.60	390.0	360.0	91.60	360.0	91.60	1350.0	73.00	1195.0	53.00	1370.0	53.00	1370.0	53.00	1370.0	
2 14 83	6	5000.0	88.60	91.60	570.0	420.0	91.60	420.0	91.60	1350.0	73.00	1195.0	53.00	1370.0	53.00	1370.0	53.00	1370.0	
2 15 83	7	2250.0	88.60	91.60	570.0	420.0	91.60	420.0	91.60	1350.0	73.00	1195.0	53.00	1370.0	53.00	1370.0	53.00	1370.0	
2 16 83	8	2250.0	88.60	91.60	570.0	420.0	91.60	420.0	91.60	1350.0	73.00	1195.0	53.00	1370.0	53.00	1370.0	53.00	1370.0	
2 17 83	9	20000.0	32.00	38.25	13600.0	12350.0	44.09	12350.0	44.09	100.0	99.91	4900.0	75.50	3600.0	75.50	3600.0	75.50	3600.0	
2 18 83	10	14667.0	60.80	44.09	5750.0	8200.0	66.19	8200.0	66.19	12.5	99.97	8050.0	63.33	7450.0	63.33	7450.0	63.33	7450.0	
2 19 83	11	21000.0	56.19	66.19	9200.0	7100.0	36.00	7100.0	36.00	5.5	99.95	7700.0	25.33	6500.0	25.33	6500.0	25.33	6500.0	
2 20 83	12	37500.0	65.07	76.83	13100.0	24000.0	77.83	24000.0	77.83	17.0	99.98	28000.0	77.56	30000.0	77.56	30000.0	77.56	30000.0	
2 21 83	13	20500.0	77.80	76.83	4550.0	4750.0	94.86	4750.0	94.86	4.5	99.86	4600.0	74.32	4700.0	74.32	4700.0	74.32	4700.0	
2 22 83	14	1460.0	90.41	94.86	140.0	75.0	95.05	75.0	95.05	2.0	99.49	375.0	89.80	35.0	89.80	35.0	89.80		
2 23 83	15	990.0	39.5	81.57	6700.0	49.0	98.31	49.0	98.31	5.0	99.87	101.0	35.82	97.0	35.82	97.0	35.82	97.0	35.82
2 24 83	16	2200.0	1235.0	94.55	120.0	113.5	92.27	113.5	92.27	9.0	100.00	4300.0	76.82	2250.0	76.82	2250.0	76.82	2250.0	
2 25 83	17	640.0	120.0	92.66	47.0	58.0	90.94	58.0	90.94	0.0	100.00	510.0	74.22	675.0	74.22	675.0	74.22	675.0	
2 26 83	18	125.0	94.40	98.40	7.0	93.75	93.75	93.75	98.40	0.0	100.00	165.0	89.20	165.0	89.20	165.0	89.20	165.0	
2 27 83	19	48.0	7.0	93.75	3.0	99.02	99.02	99.02	98.40	0.0	100.00	13.5	58.33	8.0	58.33	8.0	58.33	8.0	58.33
2 28 83	20	126.0	3.0	99.02	2.5	96.47	96.47	96.47	98.40	0.0	100.00	20.0	77.38	16.5	77.38	16.5	77.38	16.5	77.38
2 29 83	21	42.5	2.5	96.47	1.5	97.93	97.93	97.93	98.40	0.0	100.00	28.5	69.41	23.5	69.41	23.5	69.41	23.5	69.41
2 30 83	22	2000.0	1.5	97.93	41.5	67.0	96.65	67.0	96.65	0.0	99.98	530.0	73.50	5.5	73.50	5.5	73.50	5.5	73.50
2 31 83	23	2650.0	35.0	98.68	35.0	45.0	88.00	45.0	88.00	0.0	99.87	410.0	84.53	490.0	84.53	490.0	84.53	490.0	
2 32 83	24	20000.0	1205.0	96.41	790.0	2400.0	94.73	2400.0	94.73	26.0	99.95	8400.0	58.00	500.0	58.00	500.0	58.00	500.0	
2 33 83	25	66000.0	790.0	96.59	2250.0	1160.0	95.00	1160.0	95.00	12.0	99.95	8150.0	62.95	9000.0	62.95	9000.0	62.95	9000.0	
2 34 83	26	76500.0	2250.0	96.99	2300.0	3300.0	95.03	3300.0	95.03	6.0	99.99	36000.0	45.45	29500.0	45.45	29500.0	45.45	29500.0	
2 35 83	27	91500.0	2300.0	97.27	2500.0	3800.0	96.83	3800.0	96.83	9.0	99.99	27500.0	60.11	34500.0	60.11	34500.0	60.11	34500.0	
2 36 83	28	61000.0	2500.0	98.77	750.0	2900.0	97.21	2900.0	97.21	9.0	99.97	36500.0	73.77	61000.0	73.77	61000.0	73.77	61000.0	
2 37 83	29	66500.0	98.65	97.89	900.0	1700.0	97.89	1700.0	97.89	16.0	99.98	16000.0	62.41	20000.0	62.41	20000.0	62.41	20000.0	
2 38 83	30	64000.0	97.81	97.27	1400.0	1400.0	97.27	1400.0	97.27	12.0	99.85	25000.0	62.41	32500.0	62.41	32500.0	62.41	32500.0	
2 39 83	31	14000.0	1400.0	91.79	1400.0	1750.0	91.07	1750.0	91.07	97.0	99.89	2950.0	88.57	2300.0	88.57	2300.0	88.57	2300.0	

(CONTINUED)

Table D-3. (continued).

DATE	HI DY YR	DAYS OF CONTINUOUS OPERATION (DAYS)	FILTER 1 (CONTROL)			FILTER 2 (1/2 SAND BED)			FILTER 3 (CHLORINATED)			FILTER 4 (NUTRIENTS ADDED)			FILTER 5 (5°C, LARGE SAND)			FILTER 6 (5°C)		
			INFLUENT COLIFORM CONC. (NO/100ML)	EFFLUENT COLIFORM CONC. (NO/100ML)	REMOVAL (%)	EFFLUENT COLIFORM CONC. (NO/100ML)	REMOVAL (%)	EFFLUENT COLIFORM CONC. (NO/100ML)	REMOVAL (%)	EFFLUENT COLIFORM CONC. (NO/100ML)	REMOVAL (%)	EFFLUENT COLIFORM CONC. (NO/100ML)	REMOVAL (%)	EFFLUENT COLIFORM CONC. (NO/100ML)	REMOVAL (%)	EFFLUENT COLIFORM CONC. (NO/100ML)	REMOVAL (%)	EFFLUENT COLIFORM CONC. (NO/100ML)	REMOVAL (%)	
3 29 83		49		1150.0	99.87	1250.0	99.73	84.00	15.0	99.87	1600.0	86.50	1700.0	88.50						
4 5 83		56	3000.0	4.0	99.77	8.0	99.68	480.0	4.0	99.95	405.0	99.36	345.0	99.82						
4 6 83		57	2200.0	5.0	98.91	7.0	97.55	75.0	1.0	99.73	14.0	98.00	4.0	98.82						
4 7 83		58	1100.0	12.0		27.0		540.0	3.0		22.0		13.0							
4 8 83		59			99.34		98.63			99.92		95.44		88.86						
4 11 83		62	3950.0	26.0	98.03	54.0	95.67		3.0	99.83	180.0	93.83	440.0	86.00						
4 12 83		63	3000.0	59.0	99.43	130.0	99.34		5.0	99.97	185.0	98.13	420.0	98.51						
4 13 83		64	6700.0	38.0		44.0			2.0		125.0		100.0							
4 14 83		65																		
4 16 83		67																		
4 21 83		72																		
4 22 83		73																		
4 25 83		76	145000.0	1500.0	98.97	850.0	99.41		7.0	100.00	4200.0	97.10	2100.0	98.55						
4 26 83		77	125000.0	900.0	99.28	510.0	99.59		2.0	100.00	3400.0	97.28	2000.0	98.40						
4 27 83		78	215000.0	2100.0	99.02	1150.0	99.47		13.0	99.99	3150.0	98.53	7100.0	96.70						
4 28 83		79																		
5 3 83		84																		
5 4 83		85																		
5 15 83		96																		
5 16 83		97	113000.0	450.0	99.60	6050.0	94.65	36.73	66.0	99.94	22500.0	80.09	3400.0	96.99						
5 17 83		98	70500.0	310.0	99.53	4200.0	94.04	17.73	58.0	99.92	18000.0	74.47	4100.0	94.18						
5 18 83		99	72500.0	425.0	99.41	4300.0	94.07	4.14	250.0	99.66	13450.0	81.45	4250.0	91.79						
5 19 83		100	70000.0	430.0	99.39	4050.0	94.21	29.29	245.0	99.65	18000.0	74.29	5750.0	91.79						
5 20 83		101																		
5 23 83		104	63000.0	240.0	99.62	1120.0	98.22	19.05	23.0	99.96	10500.0	83.33	3200.0	94.92						
5 24 83		105	69000.0	180.0	99.74	1700.0	97.54	55.80	12.0	99.98	10300.0	85.07	3200.0	93.77						
5 25 83		106	69000.0	330.0	99.52	1700.0	98.17	39.13	14.0	99.98	16000.0	76.81	4300.0	94.86						
5 26 83		107	56500.0	360.0	99.36	1260.0	97.98	42.48	9.0	99.98	9870.0	82.53	3550.0	94.34						
5 27 83		108				1140.0														
5 30 83		111	64000.0	190.0	99.70	430.0	99.33	62.50	2.0	100.00	4700.0	92.66	3200.0	98.45						
5 31 83		112	52500.0	655.0	98.75	2300.0	95.62	37.14	27.0	99.95	10450.0	80.10	990.0	90.67						
6 1 83		113	35500.0	320.0	99.10	715.0	97.99	23.94	5.0	99.99	6050.0	82.96	4900.0	86.34						
6 2 83		114																		
6 27 83		139	35000.0	180.0	99.49	420.0	98.80	65.71	4.0	99.99	3100.0	91.14	2800.0	92.00						
6 28 83		140	38000.0	440.0	98.04	530.0	98.61	36.84	3.0	99.99	5200.0	86.32	2800.0	86.84						
6 29 83		141	49000.0	710.0	98.55	1000.0	97.96	63.27	7.0	99.99	5400.0	88.98	6900.0	85.92						
6 30 83		142	33000.0	610.0	98.15	820.0	97.52	39.39	11.0	99.97	7200.0	78.18	6100.0	81.52						
7 1 83		143																		
7 4 83		146	930.0	30.0	96.77	29.0	96.88	51.61	0.0	100.00	320.0	65.59	265.0	71.51						
7 5 83		147	2300.0	30.0	96.83	29.0	96.74	54.78	0.0	100.00	320.0	78.26	265.0	74.35						

(CONTINUED)

Table D-3. (continued).

DATE MM DY YR	DAYS OF CONTINUOUS OPERATION (DAYS)	FILTER 1 (CONTROL)			FILTER 2 (1/2 SAND BED)			FILTER 3 (CHLORINATED)			FILTER 4 (NUTRIENTS ADDED)			FILTER 5 (5°C, LARGE SAND)			FILTER 6 (5°C)		
		INFLUENT COLIFORM CONC. (NO/100ML)	EFFLUENT COLIFORM CONC. (NO/100ML)	REMOVAL (%)	EFFLUENT COLIFORM CONC. (NO/100ML)	REMOVAL (%)	EFFLUENT COLIFORM CONC. (NO/100ML)	REMOVAL (%)	EFFLUENT COLIFORM CONC. (NO/100ML)	REMOVAL (%)	EFFLUENT COLIFORM CONC. (NO/100ML)	REMOVAL (%)	EFFLUENT COLIFORM CONC. (NO/100ML)	REMOVAL (%)	EFFLUENT COLIFORM CONC. (NO/100ML)	REMOVAL (%)	EFFLUENT COLIFORM CONC. (NO/100ML)	REMOVAL (%)	
7 6 83	148	3200.0	73.0	97.44	75.0	97.19	1040.0	50.00	0.0	99.98	500.0	82.50	590.0	79.06					
7 7 83	149	4250.0	82.0	97.93	90.0	98.14	1600.0	81.41	.5	100.00	560.0	92.47	670.0	72.47					
7 8 83	150		88.0		79.0		790.0		0.0		320.0		1170.0						
7 11 83	153	35.0		98.57		91.43		45.73		100.00		20.00		-11.43					
7 12 83	154	66.0	.5	99.24	3.0	96.97	19.0	80.30	0.0	100.00	28.0	62.12	39.0	74.24					
7 13 83	155	76.0	.5	99.34	2.0	97.37	13.0	90.79	0.0	100.00	25.0	90.79	17.0	72.37					
7 14 83	156	74.0	.5	99.32	2.0	97.30	7.0	83.78	0.0	100.00	7.0	82.43	21.0	79.73					
7 15 83	157	31.0	.5		2.0		12.0		0.0		13.0		15.0						
7 18 83	160	340.0		95.59		95.29		61.76		99.85		95.00		92.06					
7 19 83	161	230.0	15.0	90.87	16.0	91.74	130.0	62.61	.5	100.00	17.0	84.78	27.0	87.83					
7 20 83	162	290.0	21.0	95.52	19.0	94.83	86.0	62.07	0.0	100.00	35.0	73.79	28.0	79.31					
7 21 83	163	310.0	13.0	86.77	15.0	89.35	110.0	35.48	0.0	100.00	76.0	71.94	60.0	78.06					
7 22 83	164	2100.0	41.0	87.62	33.0	81.43	200.0		0.0	99.90	87.0	76.67	68.0	85.71					
7 23 83	165	2300.0	260.0	93.48	390.0	93.48		43.48	2.0	99.91	490.0	75.65	300.0	77.83					
7 24 83	166	2300.0	150.0	90.87	150.0	91.30	1300.0	39.13	2.0	99.91	560.0	77.39	510.0	83.04					
7 25 83	167	2000.0	210.0	91.50	200.0	93.00	1400.0	25.00	2.0	99.85	520.0	76.25	390.0	81.75					
7 26 83	168	20500.0	170.0	96.00	140.0	96.15	1500.0	74.15	3.0	99.94	475.0	93.66	365.0	95.37					
7 27 83	169	12000.0	820.0	94.58	790.0	94.25	5300.0	60.00	12.0	99.93	1300.0	87.92	950.0	89.58					
7 28 83	170	6600.0	650.0	94.85	690.0	93.94	4800.0		9.0	99.91	1450.0	87.12	1250.0	88.64					
7 29 83	171		340.0		400.0				6.0		850.0		750.0						
8 1 83	174	34500.0		93.04		90.43		45.60		99.04		91.88		93.62					
8 2 83	175	24000.0	2400.0	76.25	3300.0	71.25	16700.0	-56.25	330.0	98.50	2800.0	84.58	2200.0	94.58					
8 3 83	176	37500.0	5700.0	90.67	6900.0	92.00	37500.0	4.00	360.0	99.39	3700.0	92.27	1300.0	97.07					
8 4 83	177	25000.0	3500.0	93.60	3000.0	92.80	36000.0	76.00	230.0	99.86	2900.0	84.60	1100.0	91.00					
8 5 83	178		1600.0		1800.0		6000.0		35.0		3850.0		2250.0						
8 8 83	181	113500.0		93.92		93.17		48.90		99.98		87.14		96.08					
8 9 83	182	129300.0	6900.0	87.47	7750.0	79.12	58000.0	56.69	20.0	99.98	14600.0	69.84	4450.0	88.79					
8 10 83	183	280000.0	16200.0	97.14	27000.0	96.96	56000.0	80.71	28.0	99.91	39000.0	88.75	14500.0	93.75					
8 11 83	184	110000.0	8000.0	93.18	8500.0	90.00	54000.0	54.55	260.0	99.95	31500.0	78.64	17500.0	88.18					
8 12 83	185		7500.0		11000.0		50000.0		51.0		23500.0		13000.0						

Table D-4. Statistical summary of total coliform data in Table D-3.

		Filter 1	Filter 2	Filter 3	Filter 4	Filter 5	Filter 6
All Available Data	Number of Samples	82	82	43	81	82	82
	Geometric Average Influent Concentration (No/100mL)	7102	7102	8286	7135	7102	7102
	Geometric Average Effluent Concentration (No/100mL)	223	333	3531	9	1192	915
	Average Percent Removal (%)	96.9	95.3	57.3	99.9	83.2	87.1
Established Operation	Number of Samples	26	26	24	26	26	26
	Geometric Average Influent Concentration (No/100mL)	2510	2510	2429	2510	2510	2510
	Geometric Average Effluent Concentration (No/100mL)	63	95	696	2	418	389
	Average Percent Removal (%)	96.2	60.1	99.9	83.3	84.5	84.5



Table D-5: Total coliform data for Phase III slow sand filtration testing.

DATE	MN DY YR	DAYS OF CONTINUOUS OPERATION (DAYS)	FILTER 1 (CONTROL)		FILTER 2 (DE. COATED)		FILTER 3 (SMALL SAND)		FILTER 4 (CONTROL)		FILTER 5 (LARGE SAND)		FILTER 6 (2°C)	
			INFLUENT COLIFORM CONC. (NO/100ML)	EFFLUENT COLIFORM CONC. (NO/100ML)	REMOVAL (%)	EFFLUENT COLIFORM CONC. (NO/100ML)	REMOVAL (%)	EFFLUENT COLIFORM CONC. (NO/100ML)	REMOVAL (%)	EFFLUENT COLIFORM CONC. (NO/100ML)	REMOVAL (%)	EFFLUENT COLIFORM CONC. (NO/100ML)	REMOVAL (%)	EFFLUENT COLIFORM CONC. (NO/100ML)
8 15 83		188	113000.0	7700.0	93.19	90.00	46.02	99.88	130.0	14000.0	97.61	96.46		
8 16 83		189	73500.0	7200.0	90.20	92.79	45.58	99.73	195.0	5500.0	92.52	95.85		
8 17 83		190	77000.0	6200.0	91.95	88.31	31.17	99.58	320.0	6400.0	91.69	94.68		
8 18 83		191												
8 22 83		195	65700.0	7000.0	89.35	93.76	49.77	98.68	870.0	10900.0	83.41	93.91		
8 23 83		196	78000.0	6300.0	91.92	91.28	58.97	98.83	910.0	11500.0	85.26	93.21		
8 24 83		197	80500.0	4600.0	94.29	93.91	56.52	98.27	1390.0	19000.0	76.40	93.42		
8 25 83		198												
8 29 83		202	70000.0	4200.0	94.00	95.71	67.14	98.27	1210.0	11200.0	84.00	91.00		
8 30 83		203	70000.0	4950.0	92.93	92.79	65.71	97.86	1500.0	10700.0	84.71	93.50		
9 1 83		204												
9 5 83		208	58000.0	3100.0	94.66	95.86	87.24	97.76	1300.0	5250.0	90.95	95.52		
9 6 83		209	75000.0	4850.0	93.53	95.87	73.33	97.07	2200.0	7250.0	90.33	96.00		
9 7 83		210	80000.0											
9 26 83		229	123000.0	1050.0	99.15	99.43	94.31	99.50	610.0	2150.0	98.25	96.38		
9 27 83		230	120000.0	1400.0	98.83	98.08	88.33	98.67	1600.0	7350.0	93.88	93.75		
9 28 83		231	70000.0	1650.0	97.64	98.14	86.00	98.14	1300.0	2650.0	96.21	95.43		
9 29 83		232												
9 30 83		233												
10 11 83		245	2.0	1.0	50.00	50.00	50.00	100.00	0.0	0.0	100.00	-300.00		
10 12 83		246	4.0	0.0	100.00	1.0	100.00	1.0	0.0	0.0	87.50	8.0		
10 13 83		247	0.0	0.0		0.0			.5	.5		-287.50		
10 14 83		248	3.4	0.0	85.29	0.0	100.00	0.0	0.0	0.0	100.00	15.5		
10 15 83		249	2.6	.5	100.00	42.31	100.00	100.00	0.0	0.0	100.00	10.0		
10 16 83		250	1.4	0.0	100.00	1.5	100.00	0.0	.5	1.0	61.54	-17.65		
10 17 83		251	1.3	0.0		0.0			0.0	0.0	100.00	4.0		
10 26 83		260	.7	0.0	100.00	100.00	100.00	100.00	0.0	0.0	100.00	6.5		
10 27 83		261	.7	0.0								-292.86		
11 5 83		270	.6	.6	16.67	100.00	100.00	100.00	0.0	.5	28.57	5.5		
11 6 83		271	.6	.5	97.40	0.0	100.00	100.00	0.0	0.0	100.00	-185.71		
11 7 83		272	1540.0	40.0	94.25	0.0	98.44	100.00	0.0	0.0	100.00	2.0		
11 8 83		273	1530.0	88.0	96.17	24.0	97.78	125.0	45.0	0.0	100.00	100.00		
11 9 83		274	2350.0	90.0		34.0	98.60	230.0	69.0	280.0	80.07	0.0		
11 10 83		275	1950.0			33.0		170.0	69.0	305.0	91.06	69.0		
11 13 83		278							91.0	210.0		94.26		
11 14 83		279										135.0		
11 15 83		280												
11 16 83		281												
11 17 83		282												
11 18 83		283												

(CONTINUED)

Table D-5. (continued).

DATE	MW DY YR	DAYS OF CONTINUOUS OPERATION (DAYS)	INFLUENT		FILTER 1 (CONTROL)		FILTER 2 (DE. COATED)		FILTER 3 (SMALL SAND)		FILTER 4 (CONTROL)		FILTER 5 (LARGE SAND)		FILTER 6 (2°C)	
			COLIFORM CONC. (NO/100ML)	REMOVAL (%)	COLIFORM CONC. (NO/100ML)	REMOVAL (%)	COLIFORM CONC. (NO/100ML)	REMOVAL (%)	COLIFORM CONC. (NO/100ML)	REMOVAL (%)	COLIFORM CONC. (NO/100ML)	REMOVAL (%)	COLIFORM CONC. (NO/100ML)	REMOVAL (%)	COLIFORM CONC. (NO/100ML)	REMOVAL (%)
11 19 83		284	2300.0	98.89	25.5	98.19	9.5	99.89	98.80	27.5	99.70	85.0	98.09	196.0	91.48	
11 20 83		285	2350.0	99.19	19.0	98.29	2.5	99.10	99.70	7.0	97.40	45.0	95.41	148.0	93.70	
11 21 83		286	2900.0	98.29	49.5	98.69	26.0	99.31	97.40	75.5	98.49	133.0	95.71	305.0	89.48	
11 22 83		287	2450.0	98.69	32.0	97.50	17.0	98.90	97.10	37.0	97.10	105.0	95.38	213.0	91.31	
11 23 83		288	2600.0	97.50	65.0	99.11	28.5	99.69	97.10	75.5	99.11	120.0	96.71	280.0	89.23	
11 24 83		289	2250.0	99.11	20.0	98.83	7.0	99.17	99.09	20.0	99.09	74.0	96.26	165.0	92.67	
11 25 83		290	2300.0	98.83	27.0	98.40	19.0	98.50	98.50	21.0	97.26	86.0	94.44	139.0	91.60	
11 26 83		291	2500.0	98.40	40.0	96.98	37.5	98.21	98.21	68.5	96.91	139.0	94.19	210.0	88.93	
11 27 83		292	2150.0	96.98	65.0		38.5			66.5		125.0		238.0		
11 28 83		293														
11 29 83		294														
11 30 83		295														
12 1 83		296														
12 14 83		309														
12 15 83		310														
12 16 83		311														
12 17 83		312														
12 18 83		313														
12 19 83		314														
12 20 83		315														
12 21 83		316														
12 22 83		317														
12 23 83		318														

Table D-6. Statistical summary of total coliform data in Table D-5.

		Filter 1	Filter 2	Filter 3	Filter 4	Filter 5	Filter 6
All Available Data	Number of Samples	25	16	25	25	25	25
	Geometric Average Influent Concentration (No./100mL)	14398	39284	14398	14398	14398	14398
	Geometric Average Effluent Concentration (No./100mL)	439	1469	913	192	1043	915
	Average Percent Removal (%)	96.9	96.3	93.6	98.7	92.8	93.6
Established Operation	Number of Samples	9	6	9	9	9	9
	Geometric Average Influent Concentration (No./100mL)	2413	13373	2413	2413	2413	2413
	Geometric Average Effluent Concentration (No./100mL)	35	195	16	35	96	204
	Average Percent Removal (%)	98.6	98.5	99.4	98.6	96.0	91.6

## APPENDIX E

### Fecal Coliform Data for Slow Sand Filtration 2/1982 - 6/1982

Table E-1 contains the results of fecal coliform testing for the period February 1982 to June 1982 for each of the Phase I filters. This table shows the influent and effluent fecal coliform data, as in Tables A-1, A-2 and A-3, Appendix A, as well as daily removal percentages. The removals have been calculated using the influent value from the previous day to account for residence time in the filter.

Table E-2 is a statistical summary of the fecal coliform data in Table E-1. It contains the total number of samples analyzed, the average influent and effluent fecal coliform concentration and the average removal percentage achieved by each filter.

Table E-1. Fecal Coliform Data for Slow Sand Filtration,  
2/1982 - 6/1982 (page 1 of 1)

DATE BY MO YR	TEMP (°C)	FILTER NO.1 (0.04 m/h)			FILTER NO.2 (0.12 m/h)			FILTER NO.3 (0.40 m/h)					
		INFLUENT COLIFORM (NO/100ML)	SCHMUTZ- DECKE AGE (WEEKS)	EFFLUENT COLIFORM (NO/100ML)	PERCENT REMOVAL (%)	SCHMUTZ- DECKE AGE (WEEKS)	EFFLUENT COLIFORM (NO/100ML)	PERCENT REMOVAL (%)	SCHMUTZ- DECKE AGE (WEEKS)	EFFLUENT COLIFORM (NO/100ML)	PERCENT REMOVAL (%)		
26	2	82	5	30000.0									
27	2	82	5	700.0	0	110.0	99.63	0	1350.0	95.50	0	1100.0	96.33
28	2	82	5	200.0	0	28.0	96.00	0	87.0	87.57	0	77.0	89.00
1	3	82	3	1.0	1	6.0	97.00	1	16.0	92.00	1	8.0	96.00
2	3	82	5										
3	3	82	5										
9	3	82	13	35000.0	1	0.0		1	5.0		1	1.0	
10	3	82	15		2	1.0	100.00	2	17.0	99.95	2	17.0	99.95
11	3	82	15		2	0.0		2	0.0		2	6.0	
12	3	82	15		2	0.0		2	0.0		2	0.0	
13	3	82	15	500.0									
14	3	82	15	1240.0	2	1.0	99.80	2	0.0	100.00	2	0.0	100.00
15	3	82	15	160.0	3	1.0	99.92	3	1.0	99.92	3	10.0	99.19
16	3	82	15	160.0	3	0.0	100.00	3	0.0	100.00	3	0.0	100.00
17	3	82	15	360.0	3	0.0	100.00	3	0.0	100.00	3	0.0	100.00
18	3	82	15	6300.0	3	0.0	100.00	3	0.0	100.00	3	0.0	100.00
19	3	82	15	6100.0	3	0.0	100.00	3	0.0	100.00	3	3.0	99.95
20	3	82	15	4900.0	3	0.0	100.00	3	1.0	99.98	3	16.0	99.74
21	3	82	15	3900.0	3	0.0	100.00	3	0.0	100.00	3	7.0	99.86
22	3	82	15	0.0	4	0.0	100.00	4	0.0	100.00	4	3.0	99.92
23	3	82	15	0.0	4	0.0		4	0.0		4	1.0	
1	4	82	5	160.0									
2	4	82	5	98.0	5	0.0	100.00	5	1.0	99.38	5	5.0	96.88
3	4	82	5	130.0	5	0.0	100.00	5	1.0	98.98	5	10.0	89.80
4	4	82	5	70.0	5	1.0	99.23	5	3.0	97.69	5	12.0	90.77
5	4	82	5	2.0	6	0.0	100.00	6	0.0	100.00	6	9.0	87.14
6	4	82	5	0.0	6	0.0	100.00	6	0.0	100.00	6	0.0	100.00
8	6	82	13	490.0	0	0.0		0	4.0		0	18.0	
9	6	82	15	1100.0	1	0.0	100.00	1	0.0	100.00	1	2.0	99.59
10	6	82	15	1800.0	1	0.0	100.00	1	4.0	99.64	1	2.0	99.82
11	6	82	15	1600.0	1	0.0	100.00	1	0.0	100.00	1	5.0	99.72
12	6	82	15		1	0.0	100.00	1	0.0	100.00	1	0.0	100.00
17	6	82	15	26.0	2	0.0		2	0.0		2	0.0	
18	6	82	15	31.0	2	0.0	100.00	2	0.0	100.00	2	0.0	100.00
21	6	82	15	29.0	2	0.0		2	0.0		2	0.0	
22	6	82	15	66.0	2	0.0	100.00	2	0.0	100.00	2	0.0	100.00
23	6	82	15	118.0	3	0.0	100.00	3	0.0	100.00	3	0.0	100.00
24	6	82	15	190.0	3	0.0	100.00	3	0.0	100.00	3	0.0	100.00
25	6	82	15		3	0.0	100.00	3	0.0	100.00	3	0.0	100.00

NOTE: REMOVALS ARE CALCULATED WITH THE INFLUENT FROM THE PREVIOUS DAY TO ACCOUNT FOR RESIDENCE TIME IN THE FILTER

Table E-2. Statistical summary of fecal coliform data in Table E-1.

	Filter 1 (0.04m/hr)	Filter 2 (0.12m/hr)	Filter 3 (0.40m/hr)
Number of Samples	27	27	27
Geometric Average Influent Concentration (No/100mL)	444.2	444.2	444.2
Geometric Average Effluent Concentration (No/100mL)	1.4	2.1	4.0
Average Percent Removal (%)	99.68	99.53	99.11

## APPENDIX F

### Standard Plate Count Data for Slow Sand Filtration 2/1982 - 1/1983

Tables F-1, F-3, and F-5 contain the results of standard plate count testing for the Phase I, Phase II, and Phase III testing. These tables show the influent and effluent standard plate count bacteria data, as well as daily removal percentages. These removals have been calculated using the influent value from the previous day to account for residence time in the filter.

Tables F-2, F-4, and F-6 are statistical summaries of the standard plate count bacteria data. They contain the total number of samples analyzed, the average influent and effluent standard plate count bacteria concentrations and the average removal percentage achieved by each filter. These calculations were performed two ways; first using all available data and second using only days having data available for all three filters.

Table F-1. Standard Plate Count Data for Slow Sand Filtration, 2/1982 - 1/1983 (page 1 of 3)

DY	MO	YR	TEMP (°C)	FILTER NO.1 (0.04 m/h)			FILTER NO.2 (0.12 m/h)			FILTER NO.3 (0.40 m/h)			
				INFLUENT BACTERIA (NO./ML)	SCHMUTZ- DECKE AGE (WEEKS)	EFFLUENT BACTERIA (NO./ML)	PERCENT REMOVAL (%)	SCHMUTZ- DECKE AGE (WEEKS)	EFFLUENT BACTERIA (NO./ML)	PERCENT REMOVAL (%)	SCHMUTZ- DECKE AGE (WEEKS)	EFFLUENT BACTERIA (NO./ML)	PERCENT REMOVAL (%)
3	2	82	15	6200.0									
4	2	82	15	9400.0									
5	2	82	15	30000.0	23	840.0	86.45	31	21300.0	-243.50	23	990.0	84.03
6	2	82	15	6000.0	23	14000.0	-48.94	31	14000.0	-48.94	23	1600.0	82.98
7	2	82	15	4100.0	23	1720.0	94.27	32	20400.0	32.00	23	4800.0	84.00
8	2	82	15	6800.0	24	470.0	92.17	32	10200.0	-70.00	24	640.0	89.33
9	2	82	15	900.0	24	1090.0	73.41	32	3800.0	7.32	24	16100.0	-292.60
10	2	82	15	4400.0	24	5300.0	22.06	32	2960.0	56.47	24	6100.0	10.29
11	2	82	15	2400.0	24	880.0	2.22	32	2600.0	-188.80	24	14100.0	-1466.00
12	2	82	15	1200.0	24	1400.0	68.18	32	4800.0	-9.09	24	140.0	96.82
13	2	82	15	1800.0	24	630.0	73.75	32	30000.0	-1150.00	24	1600.0	33.33
14	2	82	15	3200.0	25	1260.0	-5.00	33	6000.0	-400.00	25	540.0	55.00
15	2	82	15	200.0	25	10300.0	-472.20	33	5900.0	-227.70	25	30000.0	-1566.00
16	2	82	15	7200.0	25	1200.0	62.50	33	1190.0	62.81	25	800.0	75.00
26	2	82	5	360.0		3400.0	-1600.00	33	2300.0	-1050.00	25	700.0	-250.00
27	2	82	5	300.0	0	1310.0	-263.80	0	570.0	-58.33	0	940.0	-161.10
28	2	82	5	260.0	0	1730.0	-476.60	0	500.0	-66.67	0	3000.0	-900.00
1	3	82	5	350.0	1	1030.0	-296.10	1	1710.0	-557.60	1	3600.0	-1284.00
3	3	82	5	960.0	1	520.0		1	420.0		1	630.0	
13	3	82	15	176.0									
14	3	82	15	300.0	2	390.0	-121.50	2	540.0	-206.80	2	450.0	-155.60
15	3	82	15	157.0	3	180.0	40.00	3	770.0	-156.60	3	340.0	-13.33
16	3	82	15	350.0	3	270.0	-71.97	3	710.0	-352.20	3	460.0	-192.90
17	3	82	15	319.0	3	110.0	68.57	3	1050.0	-200.00	3	330.0	5.71
18	3	82	15	7900.0	3	1910.0	-498.70	3	980.0	-207.20	3	330.0	-3.45
19	3	82	15	8500.0	3	1840.0	76.71	3	400.0	94.94	3	750.0	90.51
20	3	82	15	17900.0	3	4200.0	50.59	3	840.0	90.12	3	980.0	88.47
21	3	82	15	40000.0	3	200.0	98.88	3	8900.0	50.28	3	1770.0	90.11
22	3	82	15	300.0	4	410.0	98.98	4	330.0	99.18	4	1550.0	96.13
23	3	82	15	460.0	4	190.0	36.67	4	380.0	-26.67	4	1810.0	-503.30
1	4	82	5	21900.0									
2	4	82	5	24300.0	5	8400.0	61.64	5	4400.0	79.91	5	15100.0	31.05
3	4	82	5	19000.0	5	1650.0	93.21	5	5000.0	79.42	5	12500.0	48.56
4	4	82	5	15100.0	5	1100.0	94.21	5	3200.0	83.16	5	9100.0	52.11
5	4	82	5	1040.0	6	1500.0	90.07	6	3550.0	76.49	6	7600.0	49.67
6	4	82	5	310.0	6	660.0	36.54	6	1070.0	-2.88	6	1350.0	-29.81
17	5	82	15	5800.0									
18	5	82	15	1010000.0	12	8300.0	-43.10	12	290.0	95.00	2	1200.0	79.31
19	5	82	15	6400.0	12	4300.0	99.57	12	430.0	99.96	2	2150.0	99.79
20	5	82	15	8500.0	12	670.0	89.53	12	450.0	92.97	2	440.0	93.13
21	5	82	15	23300.0	12	9700.0	-14.12	12	1170.0	86.24	2	780.0	90.82
22	5	82	15	68000.0									
23	5	82	15	22200.0	12	820.0	98.79	12	680.0	99.00	3	5100.0	92.50
24	5	82	15	28100.0	13	620.0	97.21	13	650.0	97.07	3	21700.0	2.25
25	5	82	5	10300.0	13	700.0	97.51	13	1795.0	93.61	3	1265.0	95.50
26	5	82	5	13200.0	13	8600.0	16.50	13	540.0	94.76	3	1795.0	82.57
27	5	82	5	2900.0	13	7400.0	43.94	13	730.0	94.47	3	3200.0	75.76
28	5	82	5	9100.0	13	1490.0	48.62	13	2320.0	20.00	3	1440.0	50.34
29	5	82	5		13	1330.0	85.38	13	490.0	94.62	4	1200.0	86.81
6	6	82	15	4200.0									
7	6	82	15	5100.0	0	640.0	84.76	0	830.0	80.24	0	1500.0	64.29
8	6	82	15	3020.0	0	30.0	99.41	0	350.0	93.14	0	330.0	93.53
9	6	82	15	2980.0	1	6200.0	-105.30	1	250.0	91.72	1	800.0	73.51
10	6	82	15	12100.0	1	600.0	79.87	1	232.0	92.21	1	620.0	79.19
11	6	82	15	7600.0	1	580.0	95.21	1	310.0	97.44	1	680.0	94.38
12	6	82	15		1	2000.0	73.68	1	140.0	98.16	1	390.0	94.87
17	6	82	15	3450.0	2	500.0		2	260.0		2	170.0	
18	6	82	15	5800.0	2	300.0	91.30	2	1455.0	57.83	2	990.0	71.30
20	6	82	15	2670.0									
21	6	82	15	2265.0	2	320.0	88.01	2	236.0	91.16	2	290.0	89.14
22	6	82	15	2725.0	2	250.0	88.96	2	130.0	94.26	2	340.0	84.99
23	6	82	15	2520.0	3	350.0	87.16	3	181.0	93.36	3	245.0	91.01
24	6	82	15	3910.0	3	210.0	91.67	3	161.0	93.61	3	160.0	93.65
25	6	82	15		3	1430.0	63.43	3	280.0	92.84	3	209.0	94.65
28	6	82	15	380.0									
29	6	82	15	1070.0	3	144.0	62.11	3	156.0	58.95	3	168.0	55.79
30	6	82	15	800.0	4	273.0	74.49	4	59.0	94.49	4	265.0	75.23
1	7	82	15	640.0	4	492.0	38.50	4	141.0	82.38	4	275.0	65.63
2	7	82	15	1300.0	4	560.0	12.50	4	452.0	29.38	4	130.0	79.69

NOTE: REMOVALS ARE CALCULATED WITH THE INFLUENT FROM THE PREVIOUS DAY TO ACCOUNT FOR RESIDENCE TIME IN THE FILTER



Table F-1. Standard Plate Count Data for Slow Sand Filtration, 2/1982 - 1/1983 (page 2 of 3)

DY	MO	YR	TEMP (°C)	FILTER NO.1 (0.04 m/h)			FILTER NO.2 (0.12 m/h)			FILTER NO.3 (0.40 m/h)			
				INFLUENT BACTERIA (NO/1ML)	SCHMUTZ- DECKE AGE (WEEKS)	EFFLUENT BACTERIA (NO/1ML)	PERCENT REMOVAL (%)	SCHMUTZ- DECKE AGE (WEEKS)	EFFLUENT BACTERIA (NO/1ML)	PERCENT REMOVAL (%)	SCHMUTZ- DECKE AGE (WEEKS)	EFFLUENT BACTERIA (NO/1ML)	PERCENT REMOVAL (%)
4	7	82	5	1785.0									
5	7	82	5	2655.0	0	4100.0	-129.60	0	1330.0	25.49	0	1620.0	9.24
6	7	82	5	2800.0	0	850.0	67.98	0	550.0	79.28	0	750.0	71.75
7	7	82	5	2785.0	1	1050.0	62.50	1	770.0	72.50	1	1340.0	52.14
8	7	82	5	2875.0	1	1620.0	41.83	1	440.0	84.20	1	1000.0	64.09
9	7	82	5	1790.0	1	350.0	87.83	1	390.0	86.43	1	930.0	67.65
18	7	82	5	800.0									
19	7	82	5	845.0	2	500.0	37.50	2	175.0	78.13	2	605.0	24.38
20	7	82	5	1390.0	2	290.0	65.68	2	370.0	56.21	2	270.0	68.05
21	7	82	5	2045.0	3	465.0	66.55	3			3	515.0	62.95
22	7	82	5	1290.0	3	535.0	73.84	3	365.0	82.15	3	730.0	64.30
26	7	82	15	20000.0	3	270.0		3	160.0		3	460.0	
27	7	82	15	4400.0	3	230.0	98.85	3	40.0	99.80	3	220.0	98.90
28	7	82	15	1600.0	4	260.0	94.09	4	126.0	97.14	4	630.0	83.68
29	7	82	15	4500.0	4	40.0	97.50	4	0.0	100.00	4	350.0	65.63
30	7	82	15	4400.0	4	630.0	86.00	4	190.0	95.78	4	130.0	97.11
1	8	82	15	66000.0									
2	8	82	15	66000.0	4	2620.0	96.03	4	780.0	98.82	4	3900.0	91.06
3	8	82	15		4	300.0	99.55	4	1100.0	98.33	4	3600.0	94.55
4	8	82	15	15800.0									
5	8	82	15	10700.0	5	260.0	98.35	5	150.0	99.05	5	270.0	98.29
6	8	82	15		5	410.0	96.17	5	110.0	98.97	5	230.0	97.85
8	8	82	15	4500.0									
9	8	82	15	6300.0	5	3480.0	22.67	5	246.0	94.53	5	500.0	88.89
10	8	82	15	17100.0	5	85.0	98.65	5	40.0	99.37	5	150.0	97.62
11	8	82	15	17850.0	6	390.0	97.72	6	410.0	97.60	6	295.0	98.27
12	8	82	15	39900.0	6	176.0	99.01	6	114.0	99.36	6	490.0	97.25
13	8	82	15		6	131.0	99.67	6	86.0	99.78	6	256.0	99.36
16	8	82	15	7100.0									
17	8	82	15	5800.0	6	230.0	96.76	6	320.0	95.49	6	395.0	94.44
18	8	82	15	550.0	7	95.0	98.36	7	113.0	98.05	7	83.0	98.57
28	9	82	15	2250.0									
29	9	82	15	3500.0	13	11200.0	-397.70	13	170.0	92.44	13	2500.0	-11.11
30	9	82	15	2700.0	13	390.0	88.86	13	90.0	97.43	13	580.0	83.43
1	10	82	15	3350.0	13	220.0		13	175.0		13	340.0	
2	10	82	15	1100.0	13	120.0	96.42	13	380.0	88.66	13	370.0	82.99
3	10	82	15	2000.0	13	330.0	70.00	13	80.0	92.73	13	200.0	81.82
4	10	82	15	2675.0	13	605.0	69.75	13	1060.0	47.00	13	380.0	81.00
5	10	82	15	2800.0	13	366.0	86.32				13	230.0	91.40
6	10	82	15	2005.0	14	197.0	92.96	14	43.0	98.46	14	90.0	96.79
7	10	82	15	2340.0	14	660.0	67.08	14	143.0	92.87	14	185.0	90.77
8	10	82	15	3600.0	14	860.0	63.25	14	143.0	93.89	14	219.0	90.64
9	10	82	15		14	210.0	94.17	14	430.0	88.06	14	136.0	96.22
11	10	82	15	10250.0									
12	10	82	15	1700.0	14	1075.0	89.51	14	255.0	97.51	14	80.0	99.22
15	10	82	15	2350.0	15	1080.0		15	6400.0		15	85.0	
16	10	82	15		15	165.0	92.98				15	40.0	98.30
20	10	82	15	19400.0									
21	10	82	15	29750.0	16	355.0	98.17	16	1245.0	93.58	16	1245.0	93.58
22	10	82	15	670.0	16	110.0	99.63	16	830.0	97.21	16	1460.0	95.09
23	10	82	15	600.0	16	120.0	82.09	16	580.0	13.43	16	890.0	-32.84
24	10	82	15	650.0	16	139.0	76.83	16	320.0	46.67	16	320.0	13.33
25	10	82	15	420.0	16	143.0	78.00	16	305.0	53.08	16	340.0	47.69
26	10	82	15	4400.0									
27	10	82	15	7750.0	17	61.0	98.61	17	361.0	91.80	17	105.0	97.61
28	10	82	15	995.0	17	180.0	97.68	17	260.0	96.65	17	235.0	96.97
29	10	82	15	1400.0	17	75.0	92.46	17	130.0	86.93	17	165.0	83.42
30	10	82	15	450.0	17	300.0	78.57	17	80.0	94.29	17	101.0	92.79
31	10	82	15	955.0	17	115.0	74.44	17	305.0	32.22	17	142.0	68.44
1	11	82	15	12.5	17	121.5	87.28	17	6.0	99.37	17	119.0	87.54
2	11	82	15	800.0	18	235.0	-1780.00	18	80.0	-540.00	18	43.0	-244.00
3	11	82	15	16500.0	0	2750.0	-243.70	0	870.0	-8.75	0	273.0	65.88
4	11	82	15	27000.0	0	525.0	96.82	0	1010.0	93.88	0	1940.0	88.24
5	11	82	15	315.0	0	35.0	99.87	0	560.0	97.93	0	1370.0	94.93
6	11	82	15	126.0	1	50.0	84.13	1	180.0	42.86	1	420.0	-13.33
7	11	82	15	144.0	1	71.0	43.65	1	127.0	-0.79	1	27.0	78.57
8	11	82	15	111.0	1	54.0	62.50	1	84.0	41.67	1	101.0	29.86
9	11	82	15	327.0	1	64.0	42.34	1	143.5	-29.28	1	155.0	-39.64

NOTE: REMOVALS ARE CALCULATED WITH THE INFLUENT FROM THE PREVIOUS DAY TO ACCOUNT FOR RESIDENCE TIME IN THE FILTER

Table F-1. Standard Plate Count Data for Slow Sand Filtration, 2/1982 - 1/1983 (page 3 of 3)

DY	MO	YR	TEMP (°C)	FILTER NO.1 (0.04 m/h)			FILTER NO.2 (0.12 m/h)			FILTER NO.3 (0.40 m/h)			
				INFLUENT BACTERIA (NO/1ML)	SCHMUTZ- DECKE AGE (WEEKS)	EFFLUENT BACTERIA (NO/1ML)	PERCENT REMOVAL (%)	SCHMUTZ- DECKE AGE (WEEKS)	EFFLUENT BACTERIA (NO/1ML)	PERCENT REMOVAL (%)	SCHMUTZ- DECKE AGE (WEEKS)	EFFLUENT BACTERIA (NO/1ML)	PERCENT REMOVAL (%)
12	11	82	15	37500.0									
13	11	82	15	29100.0	0	1430.0	96.19	0	7350.0	80.40	0	6000.0	84.00
14	11	82	15	210.0	0	970.0	96.67	0	5700.0	80.41	0	6850.0	76.46
15	11	82	15	10.0	1	26.0	87.62	1	23.0	89.05	1	1220.0	-480.90
16	11	82	15	82.0	1	350.0	-3400.00	1	710.0	-7000.00	1	940.0	-9300.00
17	11	82	15	110.0	1	223.5	-172.50	1	182.0	-121.90	1	225.0	-174.30
18	11	82	15	3010.0	1	620.0	-463.60	1	1455.0	-1222.00	1	830.0	-654.50
19	11	82	15	1120.0	1	138.0	95.42	1	810.0	73.09	1	209.0	93.06
7	12	82	15										
8	12	82	15	11800.0	0	166500.0					4	100.0	
9	12	82	15	5600.0	0	18000.0	-52.54				4	600.0	94.92
10	12	82	15	20300.0	1	4400.0	21.43				4	210.0	96.25
11	12	82	15	13700.0	1	6100.0	69.95				4	111.5	99.45
12	12	82	15	10800.0	1	4110.0	70.00				4	247.0	98.20
13	12	82	15	2550.0	1	2310.0	78.61				5	61.0	99.44
14	12	82	15	530.0	1	1410.0	44.71				5	267.0	89.53
18	1	83	15	119500.0									
19	1	83	15	80000.0	0	113000.0	5.44						
20	1	83	15	172000.0	0	246000.0	-207.50	10	26800.0	66.50			
21	1	83	15	160000.0	1	76000.0	55.81	10	28200.0	83.60			
22	1	83	15	19500.0	1	51500.0	67.81	10	13350.0	91.66			
23	1	83	15	3700.0	1	2800.0	85.64	10	800.0	95.90			
24	1	83	15	960.0	1	2600.0	29.73	11	1000.0	72.97			
26	1	83	15	290.0	1	1630.0		11	720.0				

NOTE: REMOVALS ARE CALCULATED WITH THE INFLUENT FROM THE PREVIOUS DAY TO ACCOUNT FOR RESIDENCE TIME IN THE FILTER

Table F-2. Statistical summary of standard plate count data in Table F-1.

	Filter 1 (0.04m/hr)	Filter 2 (0.12m/hr)	Filter 3 (0.40m/hr)
All Available Data	Number of Samples	132	126
	Geometric Average Influent Concentration (No./mL)	3418.9	3004.2
	Geometric Average Effluent Concentration (No./mL)	701.3	625.3
	Average Percent Removal (%)	79.5	83.1
Calculations include only days having data for all three filters	Number of Samples	117	117
	Geometric Average Influent Concentration (No./mL)	2868.7	2868.7
	Geometric Average Effluent Concentration (No./mL)	538.0	489.3
	Average Percent Removal (%)	81.2	82.9
			76.1

Table F-3. Standard plate count data for Phase II slow sand filtration testing.

DATE MM DY YR	DAYS OF CONTINUOUS OPERATION (DAYS)	FILTER 1 (CONTROL)			FILTER 2 (1/2 SAND BED)			FILTER 3 (CHLORINATED)			FILTER 4 (NUTRIENTS ADDED)			FILTER 5 (5°C, LARGE SAND)			FILTER 6 (5°C)		
		INFLUENT SFC CONC. (NO./1ML)	EFFLUENT SFC CONC. (NO./1ML)	REMOVAL (%)	EFFLUENT SFC CONC. (NO./1ML)	REMOVAL (%)	EFFLUENT SFC CONC. (NO./1ML)	REMOVAL (%)	EFFLUENT SFC CONC. (NO./1ML)	REMOVAL (%)	EFFLUENT SFC CONC. (NO./1ML)	REMOVAL (%)	EFFLUENT SFC CONC. (NO./1ML)	REMOVAL (%)	EFFLUENT SFC CONC. (NO./1ML)	REMOVAL (%)	EFFLUENT SFC CONC. (NO./1ML)	REMOVAL (%)	
2 9 83	1	240	3345	-26983.33	3445	-27816.67	32.47	14500.0	6.49	5150.0	-500.00	330.0	-179.17						
2 10 83	2	1310	65000	-9441.98	67000	-8754.96	32.47	3600.0	-398.63	1290.0	-533.59	670.0	-16.79						
2 11 83	3	755	125000	-3105.30	116000	-284.11	32.47	4030000.0	-307533.6	1440.0	-533.59	670.0	-16.79						
2 12 83	4	74	24200	-41927.02	2900	-31454.05	32.47	12000.0	-1489.40	8300.0	-32.45	1530.0	-47.68						
2 13 83	5	985	31100	-1752.79	23350	-1158.88	32.47	8000.0	-10710.81	1000.0	-2305.41	1115.0	-2359.46						
2 14 83	6	3620	18250	-237.02	12400	-551.93	32.47	1780.0	-103.55	1780.0	-103.55	1820.0	-113.20						
2 15 83	7	4000	12200		23600		32.47	2005.0	-319.89	2005.0	26.93	2100.0	38.40						
2 16 83	8						32.47	15200.0		2645.0		2230.0							
2 17 83	9	3850	2700	-664.38	2600	-1050.68	32.47	3600.0	6.49	1290.0	-606.85	18300.0	-375.32						
2 20 83	12	365	2790	-400.00	4200	-1622.22	32.47	1820.0	-376.19	2580.0	34.92	5460.0	-1395.89						
2 21 83	13	630	3150	.55	10850	-348.82	32.47	3000.0	-419.69	410.0	-189.76	11250.0	-1685.71						
2 22 83	14	635	1337	98.45	2850	96.68	32.47	3100.0	94.20	1840.0	98.24	2960.0	-366.14						
2 23 83	15	9650	150	-136.45	320		32.47	560.0	.99	170.0	-92.12	13700.0	-41.97						
2 24 83	16	1015	2400	-234.18	1845	-494.94	32.47	2040.0	-127.85	1950.0	-307.59	6450.0	-535.47						
2 25 83	17	395	1370	-796.00	2350	-400.00	32.47	900.0	-172.00	1610.0	-688.00	1200.0	-203.80						
2 26 83	18	125	1120	-90.91	625	-59.09	32.47	340.0	34.85	905.0	-118.18	7000.0	-5500.00						
3 1 83	21	330	630	11.45	525	-83.21	32.47	215.0	-83.21	720.0	-331.30	675.0	-104.55						
3 2 83	22	131	116	.00	240		32.47	240.0	-23.33	565.0	-83.33	970.0	-640.46						
3 3 83	23	600	1500	-7152.87	1160	60.92	32.47	740.0	-3371.26	1100.0	-1911.49	2615.0	-335.83						
3 4 83	24	43	3155	65.19	7900	64.53	32.47	1510.0	73.40	875.0	82.27	112.0	-157.47						
3 5 83	26	3045	1060	-803.70	1080	-207.41	32.47	810.0	-288.89	540.0	-137.04	110.0	96.39						
3 6 83	27	135	1220	-496.97	415	-131.82	32.47	525.0	-174.24	320.0	-127.27	550.0	-307.41						
3 7 83	28	330	1970	-204.82	765		32.47	905.0	-15.66	750.0	1.20	785.0	-137.88						
3 8 83	29	415	1265	-10.05	1095	1.59	32.47	480.0	7.41	410.0	21.69	680.0	-63.86						
3 9 83	30	945	1040	-53.85	930	-18.46	32.47	875.0	-81.03	740.0	29.23	810.0	14.29						
3 10 83	31	975	1500		1155		32.47	1765.0		690.0		925.0	5.13						
3 11 83	32	595		-78.99		-10.92	32.47		19.33		73.95		15.13						
3 12 83	33	830	1065	-26.51	660	2.41	32.47	480.0	-10.84	155.0	53.61	505.0	24.10						
3 13 83	34	9950	1050	90.80	810	93.52	32.47	920.0	96.13	385.0	94.97	630.0	93.77						
3 14 83	35	700	915	2.14	645	-22.86	32.47	385.0	90.00	500.0	79.29	620.0	60.00						
3 15 83	36	775	685	-45.81	660	.65	32.47	70.0	-222.58	145.0	54.84	280.0	60.00						
3 16 83	37	850	1130		770		32.47	2500.0		350.0		310.0							
3 17 83	38		755	-76.47	615	-109.82	32.47	505.0	22.06	435.0	57.35	510.0	40.00						
3 18 83	39	340					32.47						7.35						

(CONTINUED)

Table F-3. (continued).

DATE MO DY YR	DAYS OF CONTINUOUS OPERATION (DAYS)	INFLUENT SFC CONC. (NO/1ML)	FILTER 1 (CONTROL)		FILTER 2 (1/2 SAND BED)		FILTER 3 (CHLORINATED)		FILTER 4 (NUTRIENTS ADDED)		FILTER 5 (5°C, LARGE SAND)		FILTER 6 (5°C)	
			EFFLUENT SFC CONC. (NO/1ML)	REMOVAL (%)	EFFLUENT SFC CONC. (NO/1ML)	REMOVAL (%)	EFFLUENT SFC CONC. (NO/1ML)	REMOVAL (%)	EFFLUENT SFC CONC. (NO/1ML)	REMOVAL (%)	EFFLUENT SFC CONC. (NO/1ML)	REMOVAL (%)	EFFLUENT SFC CONC. (NO/1ML)	REMOVAL (%)
3 29 83	49		600	96.56	710	95.73	47.92	265.0	96.41	145.0	82.29	315.0	87.50	
4 5 83	56	19200	660	31.53	820	13.38	-1049.68	690.0	48.41	3400.0	-154.78	2400.0	-167.52	
4 6 83	57	1570	660	67.04	1360	53.07	-1257.54	810.0	82.96	4000.0	72.63	4200.0	60.89	
4 7 83	58	1790	1075	59.00	840	34.06		305.0	53.62	490.0	96.38	700.0		
4 8 83	59		590	46.45	455	40.65		320.0	24.52	25.0	85.81	15.0	97.83	
4 11 83	62	690	345	-43.86	460	-29.82		585.0	-163.16	110.0	82.46	60.0	92.26	
4 12 83	63	775	415		370			750.0		50.0		70.0	75.44	
4 13 83	64	285	410											
4 14 83	65													
4 16 83	67													
4 21 83	72													
4 22 83	73													
4 25 83	76	1555	335	78.46	325	79.10		140.0	91.00	80.0	94.86	45.0	97.11	
4 26 83	77	1375	160	88.36	155	88.73		85.0	93.82	150.0	89.09	15.0	98.91	
4 27 83	78	2285	435	80.96	405	82.28		91.0	96.02	103.0	95.49	33.0	98.56	
4 28 83	79													
5 3 83	84													
5 4 83	85													
5 15 83	96													
5 16 83	97													
5 17 83	98	1460	515	64.73	665	54.45	51.37	310.0	78.77	215.0	85.27	90.0	93.84	
5 18 83	99	840	390	48.34	610	19.21	-3.31	710.0	86.75	260.0	65.56	55.0	92.72	
5 19 83	100	965	815	2.98	630	25.00	-334.52	780.0	51.19	260.0	68.45	55.0	88.69	
5 20 83	101		15	98.45	60	91.78	-184.97	3650.0	97.93	265.0	83.94	20.0	97.93	
5 23 83	104	1145	1265	51.53	625	86.90	68.56	2750.0	20.0	155.0	86.46	245.0	94.32	
5 24 83	105	820	555	-19.51	150	60.98	62.20	360.0	78.05	155.0	90.65	65.0	93.29	
5 25 83	106	390	980	-146.15	320	-19.23	-143.59	310.0	33.33	75.0	44.87	55.0	83.33	
5 26 83	107	670	960	-88.81	465	6.72	-474.63	950.0	48.51	215.0	89.55	65.0	63.43	
5 27 83	108		1265		625			3850.0	345.0	70.0				
5 30 83	111	680	580	14.71	300	55.88	85.29		69.85		92.65		94.85	
5 31 83	112	710	580	-35.92	405	42.96	-38.03	100.0	35.21	50.0	79.58	35.0	85.21	
6 1 83	113	630	965	-30.16	405	50.79	-134.92	980.0	33.33	145.0	89.68	105.0	94.44	
6 2 83	114		820		310			1480.0	420.0	65.0		35.0		
6 27 83	139	515		-73.79		-50.49	-1.94		50.49		17.48		59.22	
6 28 83	140	660	895	-47.73	775	31.82	-131.82	525.0	71.97	425.0	74.24	210.0	85.61	
6 29 83	141	655	975	-16.03	450	67.18	-252.67	1530.0	82.44	170.0	94.66	95.0	97.71	
6 30 83	142	420	760	-76.19	215	28.57	-744.05	2310.0	73.81	35.0	76.19	15.0	77.38	
7 1 83	143		740		300			3545.0	110.0	100.0		95.0		
7 4 83	146	224		-158.93		-31.70	75.45		28.57		73.21		77.68	
7 5 83	147	155	580	9.68	295	-45.16	-500.00	55.0	29.03	60.0	83.87	50.0	90.32	

(CONTINUED)

Table F-3. (continued).

DATE MN DY YR	DAYS OF CONTINUOUS OPERATION (DAYS)	FILTER 1 (CONTROL)			FILTER 2 (1/2 SAND BED)			FILTER 3 (CHLORINATED)			FILTER 4 (NUTRIENTS ADDED)			FILTER 5 (5°C, LARGE SAND)			FILTER 6 (5°C)		
		INFLUENT SFC CONC. (NO./IHL)	EFFLUENT SFC CONC. (NO./IHL)	REMOVAL (%)	EFFLUENT SFC CONC. (NO./IHL)	REMOVAL (%)	EFFLUENT SFC CONC. (NO./IHL)	REMOVAL (%)	EFFLUENT SFC CONC. (NO./IHL)	REMOVAL (%)	EFFLUENT SFC CONC. (NO./IHL)	REMOVAL (%)	EFFLUENT SFC CONC. (NO./IHL)	REMOVAL (%)	EFFLUENT SFC CONC. (NO./IHL)	REMOVAL (%)	EFFLUENT SFC CONC. (NO./IHL)	REMOVAL (%)	
7 6 83	148	150	140	-400.00	225	.00	930.0	-1030.00	110.0	-396.67	25.0	60.00	15.0	46.67					
7 7 83	149	515	750	21.36	360	42.72	1695.0	-503.88	745.0	75.73	60.0	98.06	80.0	91.26					
7 8 83	150		405		295		3110.0		125.0		10.0		45.0						
7 11 83	153	3000		78.83		94.00		74.00		97.50		97.83		98.67					
7 12 83	154	280	635	88.21	180	48.21	780.0	-526.79	75.0	80.36	65.0	82.14	40.0	73.21					
7 13 83	155	190	33	-171.05	145	-13.16	1755.0	-125.79	55.0	52.63	50.0	86.84	75.0	92.11					
7 14 83	156	160	515	-306.25	215	-53.13	429.0	-2612.50	90.0	-587.50	25.0	3.13	15.0	43.75					
7 15 83	157	490	650		245		4340.0		1100.0		155.0		90.0						
7 18 83	160	320		-84.38		31.25		73.44		40.63		32.81		48.44					
7 19 83	161	345	590	-71.01	220	23.19	85.0	.29	190.0	40.58	215.0	13.04	165.0	40.58					
7 20 83	162	340	590	-79.41	265	23.53	760.0	-344.12	205.0	83.82	300.0	70.59	205.0	83.82					
7 21 83	163	180	610	-163.89	260	-27.78	1510.0	3.33	55.0	2.78	100.0	-122.22	55.0	19.44					
7 22 83	164	130	475		230		174.0		175.0		400.0		145.0						
7 23 83	165																		
7 24 83	166	350		-51.43		65.71		35.71		57.14		75.71		68.57					
7 25 83	167	307	530	-49.84	120	49.51	225.0	-183.39	150.0	70.68	85.0	75.57	110.0	73.94					
7 26 83	168	325	460	.00	155	44.62	870.0	-203.08	90.0	69.23	75.0	70.77	80.0	06.15					
7 27 83	169	485	715	7.22	180	84.54	985.0	51.55	100.0	79.38	95.0	94.85	45.0	90.72					
7 28 83	170	205	450	-195.12	75		235.0		100.0	73.17	25.0	51.22	45.0	78.05					
7 29 83	171		605		205				55.0		100.0		45.0						
8 1 83	174	290		-62.07		32.76		-56.90		70.69		.00		10.34					
8 2 83	175	365	470	1.37	195	58.90	455.0	-138.36	85.0	75.34	580.0	94.52	260.0	87.67					
8 3 83	176	320	360	-47.19	150	23.44	870.0	-307.81	90.0	78.13	20.0	60.94	45.0	79.69					
8 4 83	177	370	471	-10.81	245	52.70	1305.0	-1486.49	70.0	86.49	125.0	62.16	65.0	77.03					
8 5 83	178		410		175		5870.0		50.0		140.0		85.0						
8 8 83	181	1480		93.92		90.54		62.16		98.99		93.92		92.57					
8 9 83	182	1870	90	90.64	140	84.49	560.0	-31.55	15.0	98.66	90.0	78.61	110.0	95.19					
8 10 83	183	3760	175	89.63	290	92.82	2460.0	89.71	25.0	90.96	400.0	89.76	90.0	98.27					
8 11 83	184	1055	390	61.61	270	78.67	387.0	-144.55	340.0	72.04	385.0	55.92	65.0	86.26					
8 12 83	185		405		225		2580.0		295.0		465.0		145.0						

Table F-4. Statistical summary of standard plate count data in Table F-3.

	Filter 1	Filter 2	Filter 3	Filter 4	Filter 5	Filter 6
All Available Data	Number of Samples	80	42	78	80	80
	Geometric Average Influent Concentration (No/mL)	624	595	628	624	624
	Geometric Average Effluent Concentration (No/mL)	825	604	1075	352	249
	Average Percent Removal (%)	-32	3	-80	44	60
Established Operation	Number of Samples	24	24	23	24	24
	Geometric Average Influent Concentration (No/mL)	371	371	380	371	371
	Geometric Average Effluent Concentration (No/mL)	524	240	719	156	80
	Average Percent Removal (%)	-41	35	-89	58	78

Table F-5. Standard plate count data for Phase III slow sand filtration testing.

DATE MM DY YR	DAYS OF CONTINUOUS OPERATION (DAYS)	FILTER 1 (CONTROL)			FILTER 2 (DE. COATED)			FILTER 3 (SMALL SAND)			FILTER 4 (CONTROL)			FILTER 5 (LARGE SAND)			FILTER 6 (2°C)		
		INFLUENT SFC CONC. (NO./1ML)	EFFLUENT SFC CONC. (NO./1ML)	REMOVAL (%)	EFFLUENT SFC CONC. (NO./1ML)	REMOVAL (%)	EFFLUENT SFC CONC. (NO./1ML)	REMOVAL (%)	EFFLUENT SFC CONC. (NO./1ML)	REMOVAL (%)	EFFLUENT SFC CONC. (NO./1ML)	REMOVAL (%)	EFFLUENT SFC CONC. (NO./1ML)	REMOVAL (%)	EFFLUENT SFC CONC. (NO./1ML)	REMOVAL (%)	EFFLUENT SFC CONC. (NO./1ML)	REMOVAL (%)	
8 15 83	188	1080	195	81.94	635	41.20	70.00	324.0	70.00	120.0	88.89	120.0	88.89	57.0	94.72	60.0	94.44		
8 16 83	189	1360	125	90.81	415	69.49	44.85	750.0	44.85	25.0	98.16	25.0	98.16	120.0	91.18	60.0	96.32		
8 17 83	190	835	235	71.86	1380	-65.27	-101.80	1685.0	-101.80	140.0	83.23	140.0	83.23	120.0	50.90	50.0	92.22		
8 22 83	195	1085	145	86.64	150	86.18	16.59	905.0	16.59	130.0	88.02	130.0	88.02	110.0	89.86	50.0	95.39		
8 23 83	196	99	170	-71.72	90	9.09	-187.88	285.0	-187.88	110.0	-11.11	110.0	-11.11	315.0	-218.18	50.0	54.55		
8 24 83	197	720	140	80.56	170	76.39	-1.39	730.0	-1.39	105.0	85.42	105.0	85.42	115.0	84.03	45.0	90.97		
8 25 83	198	790	25	96.84	70	91.14	48.10	410.0	48.10	125.0	84.18	125.0	84.18	95.0	87.97	55.0	93.04		
8 29 83	202	990	110	88.89	190	80.81	41.92	575.0	41.92	135.0	86.36	135.0	86.36	102.0	89.70	65.0	93.43		
9 1 83	204	1025	85	91.71	85	91.71	77.07	235.0	77.07	45.0	95.61	45.0	95.61	70.0	93.17	45.0	95.61		
9 5 83	208	795	113	85.79	152	80.88	62.89	295.0	62.89	75.0	90.57	75.0	90.57	145.0	81.76	77.0	90.31		
9 7 83	210	790	130	95.86	175	94.43	84.08	500.0	84.08	110.0	96.50	110.0	96.50	150.0	95.22	26.0	99.17		
9 26 83	229	3140	141	88.49	120	90.20	62.86	455.0	62.86	168.0	86.29	168.0	86.29	184.0	84.98	60.0	95.10		
9 27 83	230	1225	40	96.31	32	97.05	68.66	340.0	68.66	80.0	92.63	80.0	92.63	300.0	72.35	32.0	97.05		
9 28 83	231	1085	86	96.31	83	29.66	-196.61	350.0	-196.61	344.0	88.0	344.0	88.0	271.0	-129.66	17.0	81.36		
9 29 83	232	120	86	10.42	83	60.42	-168.75	350.0	-168.75	115.0	-19.79	115.0	-19.79	330.0	-243.75	22.0	79.17		
9 30 83	233	365	86	72.33	38	60.42	-168.75	258.0	-168.75	115.0	-19.79	115.0	-19.79	330.0	-243.75	22.0	79.17		
10 11 83	245	584	101	80.48	75	72.09	15.07	310.0	15.07	88.0	75.89	88.0	75.89	277.0	24.11	29.0	92.05		
10 12 83	246	584	114	80.48	75	72.09	15.07	310.0	15.07	88.0	75.89	88.0	75.89	277.0	24.11	29.0	92.05		
10 13 83	247	415	114	73.66	163	77.11	28.67	339.0	28.67	394.0	32.53	394.0	32.53	280.0	52.05	29.0	91.61		
10 14 83	248	268	101	69.78	95	64.93	-42.16	296.0	-42.16	286.0	31.08	286.0	31.08	280.0	69.40	49.0	88.92		
10 15 83	249	172	81	59.30	94	79.65	-116.28	381.0	-116.28	362.0	-35.07	362.0	-35.07	275.0	-2.61	46.0	95.52		
10 16 83	250	118	70	27.12	35	29.66	-196.61	372.0	-196.61	88.0	48.84	88.0	48.84	275.0	-44.19	12.0	90.12		
10 17 83	251	120	86	10.42	83	29.66	-196.61	372.0	-196.61	88.0	-191.53	88.0	-191.53	248.0	-129.66	17.0	81.36		
10 26 83	260	96	86	10.42	83	29.66	-196.61	372.0	-196.61	88.0	-191.53	88.0	-191.53	248.0	-129.66	17.0	81.36		
10 27 83	261	56	86	10.42	38	60.42	-168.75	350.0	-168.75	115.0	-19.79	115.0	-19.79	330.0	-243.75	22.0	79.17		
11 5 83	270	8	86	-1293.26	38	-1091.01	-3225.84	258.0	-3225.84	115.0	-1877.53	115.0	-1877.53	330.0	-3641.57	20.0	-23.60		
11 6 83	271	67	124	14.93	106	16.42	-273.13	296.0	-273.13	176.0	-113.43	176.0	-113.43	333.0	-232.84	11.0	91.04		
11 7 83	272	418	57	63.64	56	80.62	-36.36	250.0	-36.36	143.0	44.02	143.0	44.02	223.0	2.39	6.0	95.69		
11 8 83	273	93	152	-58.06	81	-13.98	-345.16	570.0	-345.16	234.0	-193.55	234.0	-193.55	408.0	-220.43	18.0	89.25		
11 9 83	274	62	147	-27.42	106	53.23	-153.23	414.0	-153.23	273.0	-88.71	273.0	-88.71	298.0	-208.06	10.0	93.55		
11 10 83	275	52	79	-515.38	29	53.23	-153.23	157.0	-153.23	117.0	-88.71	117.0	-88.71	191.0	-208.06	4.0	93.55		
11 13 83	278	13	80	-384.62	29	53.23	-153.23	157.0	-153.23	117.0	-88.71	117.0	-88.71	191.0	-208.06	4.0	93.55		
11 14 83	279	13	80	-384.62	29	53.23	-153.23	157.0	-153.23	117.0	-88.71	117.0	-88.71	191.0	-208.06	4.0	93.55		
11 15 83	280	8	63	-1250.00	8	-384.62	-3407.69	444.0	-3407.69	271.0	-1569.23	271.0	-1569.23	373.0	-1830.77	19.0	-46.15		
11 16 83	281	7	108	-2714.29	7	-2714.29	-5728.57	482.0	-5728.57	238.0	-4128.57	238.0	-4128.57	372.0	-5357.14	17.0	-112.50		
11 17 83	282	7	197	-1585.71	7	-1585.71	-3871.43	408.0	-3871.43	296.0	-3871.43	296.0	-3871.43	382.0	-5085.71	18.0	-142.86		
11 18 83	283	7	118	-1257.14	7	-1257.14	-2971.43	408.0	-2971.43	278.0	-2971.43	278.0	-2971.43	363.0	-4028.57	17.0	-171.43		

(CONTINUED)





Table F-6. Statistical summary of standard plate count data in Table F-5.

	Filter 1	Filter 2	Filter 3	Filter 4	Filter 5	Filter 6
All Available Data	Number of Samples	43	16	39	43	43
	Geometric Average Influent Concentration (No/mL)	904	629	1524	904	904
	Geometric Average Effluent Concentration (No/mL)	150	140	495	170	278
	Average Percent Removal (%)	83	78	68	81	69
Established Operation	Number of Samples	9	6	9	9	9
	Geometric Average Influent Concentration (No/mL)	118	465	118	118	118
	Geometric Average Effluent Concentration (No/mL)	99	74	118	107	149
	Average Percent Removal (%)	17	84	0	10	-26

## APPENDIX G

### Turbidity Data for Slow Sand Filtration 7/1981 - 1/1983

Tables G-1, G-3, and G-5 contain the results of turbidity monitoring for the Phase I, Phase II, and Phase III testing. These tables show the influent and effluent turbidity data, as well as daily removal percentages.

Tables G-2, G-4, and G-6 are statistical summaries of the turbidity data. They contain the total number of samples analyzed, the average influent and effluent turbidity, and the average removal percentage achieved by each filter. These calculations were performed first for all data available and again including only days having data for all three filters.

Table G-1. Turbidity Data for Slow Sand Filtration,  
7/1981 - 1/1983 (page 1 of 5)

DATE DY MO YR	TEMP (°C)	FILTER NO.1 (0.04 m/h)			FILTER NO.2 (0.12 m/h)			FILTER NO.3 (0.40 m/h)			
		INFLUENT TURBIDITY (NTU)	SCHMUTZ- DECKE AGE (WEEKS)	EFFLUENT TURBIDITY (NTU)	PERCENT REMOVAL (%)	SCHMUTZ- DECKE AGE (WEEKS)	EFFLUENT TURBIDITY (NTU)	PERCENT REMOVAL (%)	SCHMUTZ- DECKE AGE (WEEKS)	EFFLUENT TURBIDITY (NTU)	PERCENT REMOVAL (%)
1 7 81	15	5.2				0	3.5	32.69			
2 7 81	15	7.5				0	3.5	53.33			
4 7 81	15	5.5				1	4.3	21.82			
6 7 81	15	4.2				1	4.3	-2.38			
7 7 81	15	4.5				1	3.7	17.78			
8 7 81	15	5.4				1	4.1	24.07			
26 7 81	5	11.0				4	3.8	65.45			
27 7 81	5	4.5				4	3.5	22.22			
28 7 81	15	3.7				4	3.7	0.00			
29 7 81	15	3.6				4	3.6	0.00			
30 7 81	15	3.9				4	3.8	2.56			
31 7 81	15	3.9				4	3.6	7.69			
1 8 81	15	3.6				5	3.5	2.78			
2 8 81	15	3.6				5	3.5	2.78			
4 8 81	15	3.9				5	3.6	7.69			
5 8 81	15	3.7				5	3.7	0.00			
6 8 81	15	3.9				5	3.7	5.13			
7 8 81	15	4.2				5	3.1	26.19			
9 8 81	15	3.9				6	3.5	10.26			
10 8 81	15	3.4				6	3.3	2.94			
11 8 81	15	3.8				6	3.4	10.53			
12 8 81	15	3.6				6	3.3	8.33			
13 8 81	5	5.0				6	3.3	34.00			
14 8 81	5	5.0				6	3.0	40.00			
15 8 81	15	4.1				7	3.0	26.83			
17 8 81	15	3.7				7	3.9	-5.41			
18 8 81	15	3.8				7	3.8	0.00			
19 8 81	15	3.8				7	3.8	0.00			
20 8 81	15	3.7				7	3.7	0.00			
21 8 81	15	3.7				7	3.6	2.70			
22 8 81	15	7.8				8	3.4	56.41			
24 8 81	15	5.9				8	4.8	18.64			
25 8 81	15	6.0				8	3.9	35.00			
26 8 81	15	4.0				8	3.4	15.00			
27 8 81	15	4.4	0	1.2	72.73	8	2.5	43.18	0	4.4	0.00
28 8 81	15	4.4	0	.9	79.55	8	2.0	54.55	0	4.4	0.00
29 8 81	15	3.9	0	1.6	58.97	9	1.9	51.28	0	3.7	5.13
30 8 81	15	4.0	1	2.6	35.00	9	1.7	57.50	1	3.7	7.50
1 9 81	15	4.1	1	2.4	41.46	9	1.7	58.54	1	3.7	9.76
2 9 81	15	4.1	1	2.5	39.02	9	1.6	60.98	1	4.0	2.44
3 9 81	15	6.4	1	3.4	46.87	9	1.7	73.44	1	4.6	28.12
4 9 81	15	4.2	1	3.6	14.29	9	1.8	57.14	1	5.2	-23.81
5 9 81	15	4.5	1	2.7	40.00	10	1.8	60.00	1	4.5	0.00
6 9 81	15	4.4	2	2.8	36.36	10	1.7	61.36	2	4.2	4.55
7 9 81	15	4.7	2	5.8	-23.40	10	1.7	63.83	2	5.0	-6.38
8 9 81	15	4.5	2	8.0	-77.78	10	1.9	57.78	2	5.3	-17.78
9 9 81	15	4.5	2	6.3	-40.00	10	1.8	60.00	2	5.5	-22.22
10 9 81	15	4.6	2	5.7	-23.91	10	1.9	58.70	2	5.6	-21.74
11 9 81	15	4.6	2	7.8	-69.57	10	3.4	26.09	2	5.4	-17.39
12 9 81	15	5.0	2	7.6	-32.00	11	3.5	30.00	2	4.8	4.00
13 9 81	15	4.9	3	5.9	-20.41	11	4.0	18.37	3	4.7	4.08
14 9 81	15	5.8	3	4.6	20.69	11	4.3	25.86	3	4.7	18.97
17 9 81	15	6.0	3	5.4	10.00	11	4.6	23.33	3	5.3	11.67
18 9 81	15	5.8	3	4.3	25.86	11	4.8	17.24	3	5.5	5.17
19 9 81	15	5.9	3	4.4	25.42	12	4.6	22.03	3	5.5	6.78
20 9 81	15	5.5	4	4.4	20.00	12	4.6	16.36	4	5.4	1.82
21 9 81	15	5.4	4	4.4	18.52	12	4.6	14.81	4	5.1	5.56
22 9 81	15	7.2				12	4.6	36.11	4	4.7	34.72
23 9 81	15	5.8	4	4.2	27.59	12	2.8	51.72	4	5.0	13.79
24 9 81	15	5.6	4	4.7	16.07	12	3.3	41.07	4	3.2	42.86
25 9 81	15	5.7	4	4.7	17.54	12	5.2	8.77	4	5.3	7.02
26 9 81	15	5.8	4	4.6	20.69	13	5.1	12.07	4	5.3	8.62
27 9 81	15	5.9	5	4.7	20.34	13	4.7	20.34	5	5.7	3.39
28 9 81	15	6.2	5	4.5	27.42	13	4.2	32.26	5	5.2	16.13
29 9 81	15	7.0	5	4.0	42.86	13	4.4	37.14	5	5.5	21.43
30 9 81	15	7.1	5	4.5	36.62	13	4.1	42.25	5	5.5	22.54
1 10 81	15	6.4	5	4.4	31.25	13	3.4	46.87	5	5.6	12.50
2 10 81	15	6.5	5	4.6	29.23	13	5.1	21.54	5	5.9	9.23
3 10 81	5	6.5	5	4.5	30.77	14	5.0	23.08	5	5.3	18.46
4 10 81	5	6.8	6	4.7	30.88	14	5.3	22.06	6	6.3	7.35

Table G-1. Turbidity Data for Slow Sand Filtration,  
7/1981 - 1/1983 (page 2 of 5)

DATE BY MO YR	TEMP (°C)	FILTER NO.1 (0.04 m/h)			FILTER NO.2 (0.12 m/h)			FILTER NO.3 (0.40 m/h)			
		INFLUENT TURBIDITY (NTU)	SCHMUTZ- DECKE AGE (WEEKS)	EFFLUENT TURBIDITY (NTU)	PERCENT REMOVAL (%)	SCHMUTZ- DECKE AGE (WEEKS)	EFFLUENT TURBIDITY (NTU)	PERCENT REMOVAL (%)	SCHMUTZ- DECKE AGE (WEEKS)	EFFLUENT TURBIDITY (NTU)	PERCENT REMOVAL (%)
5 10 81	5	6.6	6	3.8	42.42	14	5.0	24.24	6	6.1	7.58
6 10 81	5	6.8	6	3.9	42.65	14	5.1	25.00	6	6.1	10.29
7 10 81	5	7.0	6	4.0	42.86	14	5.2	25.71	6	6.2	11.43
9 10 81	15	6.3	6	4.2	33.33	14	4.5	28.57	6	5.4	14.29
10 10 81	15	6.3	6	4.5	28.57	15	4.5	28.57	6	5.2	17.46
11 10 81	15	6.5	7	5.0	23.08	15	5.1	21.54	7	5.3	18.46
12 10 81	15	6.9	7	3.7	46.38	15	5.2	24.64	7	5.4	21.74
13 10 81	15	6.6	7	4.2	36.36	15	5.2	21.21	7	5.5	16.67
14 10 81	15	6.5	7	4.3	33.85	15	5.4	16.92	7	5.5	15.38
15 10 81	15	6.7	7	4.1	38.81	15	5.5	17.91	7	5.6	16.42
16 10 81	15	6.4	7	4.3	32.81	15	5.4	15.63	7	5.6	12.50
17 10 81	15	6.8	7	3.8	44.12	16	5.5	19.12	7	5.8	14.71
18 10 81	15	6.8	8	3.9	42.65	16	5.6	17.65	8	5.8	14.71
19 10 81	15	6.7	8	4.5	32.84	16	5.7	14.93	8	5.6	16.42
20 10 81	15	6.9	8	4.7	31.88	16	5.2	24.64	8	5.6	18.84
21 10 81	15	7.0	8	4.7	32.86	16	5.5	21.43	8	5.5	21.43
22 10 81	15	6.8	8	5.3	22.06	16	5.3	22.06	8	5.4	20.59
23 10 81	15	7.0	8	4.7	32.86	16	5.3	24.29	8	5.4	22.86
24 10 81	15	6.8	8	4.6	32.35	17	5.3	22.06	8	5.6	17.65
25 10 81	15	6.5	9	4.6	29.23	17	5.3	18.46	9	5.7	12.31
26 10 81	15	6.6	9	4.7	28.79	17	5.7	13.64	9	6.1	7.58
27 10 81	15	6.6	9	5.7	13.64	17	6.1	7.58	9	5.9	10.61
28 10 81	15	6.7	9	6.1	8.96	17	6.1	8.96	9	6.1	8.96
29 10 81	15	6.4	9	5.1	20.31	17	5.1	20.31	9	6.1	4.69
30 10 81	5	6.5	9	5.6	13.85	17	5.6	13.85	9	5.9	9.23
31 10 81	5	6.6	9	5.1	22.73	18	4.8	27.27	9	5.5	16.67
1 11 81	5	6.4	10	5.3	17.19	18	5.9	7.81	10	6.1	4.69
2 11 81	5	6.1	10	5.5	9.84	18	5.9	3.28	10	6.1	0.00
3 11 81	5	6.2	10	5.1	17.74	18	6.0	3.23	10	6.1	1.61
4 11 81	5	6.3	10	5.8	7.94	18	6.3	0.00	10	5.9	6.35
6 11 81	15	6.2	10	4.6	25.81	18	5.6	9.68	0	5.7	8.06
7 11 81	15	6.3	10	4.7	25.40	19	5.1	19.05	0	5.1	19.05
8 11 81	15	6.3	11	4.8	23.81	19	5.7	9.52	0	6.0	4.76
9 11 81	15	6.5	11	4.7	27.69	19	5.3	18.46	1	5.1	21.54
10 11 81	15	6.3	11	4.8	23.81	19	5.2	17.46	1	5.1	19.05
11 11 81	15	6.7	11	3.8	43.28	19	4.5	32.84	1	4.6	31.34
12 11 81	15	6.7	11	4.0	40.30	19	4.6	31.34	1	4.8	28.36
13 11 81	15	6.7	11	4.7	29.85	19	4.0	40.30	1	4.9	26.87
14 11 81	15	6.4	11	3.6	43.75	20	4.0	37.50	1	4.0	37.50
15 11 81	15	6.5	12	4.2	35.38	20	4.8	26.15	1	4.9	24.62
16 11 81	15	6.7	12	4.9	26.87	20	5.1	23.88	2	5.5	17.91
17 11 81	15	6.4	12	4.7	26.56	20	4.8	25.00	2	5.4	15.63
18 11 81	15	6.5	12	4.3	33.85	20	4.9	24.62	2	5.3	18.46
19 11 81	15	6.2	12	5.4	12.90	20	5.5	11.29	2	5.1	17.74
20 11 81	15	6.9	12	5.0	27.54	20	5.4	21.74	2	4.8	30.43
21 11 81	15	6.3	12	4.4	30.16	21	3.6	42.86	2	4.4	30.16
22 11 81	15	5.9	13	3.9	33.90	21	4.0	32.20	2	4.5	23.73
23 11 81	15	6.3	13	3.9	38.10	21	4.2	33.33	3	4.2	33.33
24 11 81	15	6.6	13	4.5	31.82	21	4.7	28.79	3	5.1	22.73
25 11 81	15	6.5	13	4.3	33.85	21	4.7	27.69	3	4.9	24.62
29 11 81	15	6.3	14	5.3	15.87	22	4.8	23.81	3	5.4	14.29
30 11 81	15	6.4	14	5.3	17.19	22	4.7	26.56	4	4.7	26.56
1 12 81	15	6.6	14	5.3	19.70	22	4.8	27.27	4	5.3	19.70
2 12 81	15	7.1	14	3.9	45.07	22	4.6	35.21	4	4.7	33.80
3 12 81	15	7.2	14	4.7	34.72	22	4.9	31.94	4	4.8	33.33
4 12 81	15	6.8	14	3.9	42.65	22	4.6	32.35	4	4.7	30.88
5 12 81	15	7.0	14	4.6	34.29	23	4.7	32.86	4	4.6	34.29
6 12 81	15	7.0	15	4.7	32.86	23	5.0	28.57	4	5.0	28.57
7 12 81	15	7.2	15	4.0	44.44	23	4.1	43.06	5	4.8	33.33
8 12 81	15	6.7	15	5.2	22.39	23	5.1	23.88	5	4.5	32.84
9 12 81	15	7.1	15	3.9	45.07	23	4.6	35.21	5	4.8	32.39
10 12 81	15	7.3	15	4.4	39.73	23	4.5	38.36	5	5.0	31.51
11 12 81	15	8.6	15	5.4	37.21	23	6.8	20.93	5	6.2	27.91
12 12 81	15	8.8	15	5.4	38.64	24	7.8	11.36	5	6.6	25.00
13 12 81	15	8.6	16	5.6	34.88	24	6.1	29.07	5	7.0	18.60
14 12 81	15	8.9	16	5.7	35.96	24	4.9	44.94	6	7.7	13.48
15 12 81	15	8.7	16	6.6	24.14	24	6.2	28.74	6	7.3	16.09
16 12 81	15	8.8	16	6.0	31.82	24	6.0	31.82	6	6.8	22.73
17 12 81	15	8.8	16	5.6	36.36	24	6.0	31.82	6	5.8	34.09
18 12 81	15	9.1	16	7.0	23.08	24	7.2	20.88	6	6.8	25.27

Table G-1. Turbidity Data for Slow Sand Filtration,  
7/1981 - 1/1983 (page 3 of 5)

DATE BY MO YR	TEMP (°C)	FILTER NO.1 (0.04 m/h)			FILTER NO.2 (0.12 m/h)			FILTER NO.3 (0.40 m/h)			
		INFLUENT TURBIDITY (NTU)	SCHMUTZ- DECKE AGE (WEEKS)	EFFLUENT TURBIDITY (NTU)	PERCENT REMOVAL (%)	SCHMUTZ- DECKE AGE (WEEKS)	EFFLUENT TURBIDITY (NTU)	PERCENT REMOVAL (%)	SCHMUTZ- DECKE AGE (WEEKS)	EFFLUENT TURBIDITY (NTU)	PERCENT REMOVAL (%)
20 12 81	15	8.9	17	3.8	57.30	25	4.0	55.06	6	1.2	86.52
22 12 81	15	8.7	17	3.7	57.47	25	3.9	55.17	7	2.0	77.01
23 12 81	15	9.5	17	3.7	61.05	25	3.9	58.95	7	5.0	47.37
27 12 81	15	8.9	18	4.5	49.44	26	4.2	52.81	7	4.8	46.07
31 12 81	15	8.9	18	3.5	60.67	26	4.3	49.44	8	4.8	46.07
4 1 82	15	8.8	19	3.2	63.64	27	3.8	56.82	8	4.2	52.27
8 1 82	15	7.9	19	2.4	69.62	27	3.6	54.43	9	3.9	50.63
10 1 82	15	8.0	20	2.3	71.25	28	4.0	50.00	9	4.4	45.00
15 1 82	15	8.2	20	2.8	65.85	28	3.6	56.10	10	4.0	51.22
18 1 82	15	8.1	21	3.4	58.02	29	4.1	49.38	10	4.4	45.68
22 1 82	15	8.7	21	3.3	62.07	29	3.9	55.17	11	4.8	44.83
25 1 82	15	9.2	22	3.2	65.22	30	4.0	56.52	11	4.9	46.74
28 1 82	15	10.5	22	5.0	52.38	30	5.0	52.38	12	6.7	36.19
30 1 82	15	11.0	22	4.5	59.09	31	4.4	60.00	12	6.2	43.64
2 2 82	15	11.0	23	4.2	61.82	31	3.8	65.45	12	4.9	53.45
4 2 82	15	11.0	23	4.8	56.36	31	3.7	66.36	13	4.9	55.45
6 2 82	15	9.2	23	4.8	47.83	32	3.6	60.87	13	5.0	45.65
8 2 82	15	8.5	24	4.5	47.06	32	3.2	62.35	13	5.1	40.00
12 2 82	15	6.8	24	4.5	33.82	32	3.7	45.59	14	4.9	27.94
14 2 82	15	6.3	25	4.4	30.16	33	3.0	52.38	14	4.8	23.81
18 2 82	15	6.0	25	3.8	36.67	33	2.9	51.67	15	4.0	33.33
20 2 82	15	6.2	25	7.7	-24.19	34	7.3	-17.74	15	4.2	32.26
26 2 82	5	4.0	0	4.3	-7.50	0	5.2	-30.00	0	5.3	-32.50
27 2 82	5	4.7	0	4.1	12.77	0	4.1	12.77	0	4.1	12.77
28 2 82	5	4.8	0	3.7	22.92	0	4.5	6.25	0	4.9	-2.08
1 3 82	5	5.0	1	3.6	28.00	1	4.6	8.00	1	4.6	8.00
2 3 82	5	4.7	1	3.8	19.15	1	4.5	4.26	1	4.4	6.38
3 3 82	5	5.5	1	3.6	34.55	1	4.4	20.00	1	4.2	23.64
4 3 82	15	3.8	1	3.9	-2.63	1	3.9	-2.63	1	4.1	-7.89
5 3 82	15	3.8	1	3.5	7.89	1	3.5	7.89	1	3.9	-2.63
9 3 82	15	4.5	2	4.2	6.67	2	2.9	35.56	2	3.2	28.89
13 3 82	15	3.9	2	3.1	20.51	2	3.1	20.51	2	4.0	-2.56
15 3 82	15	4.1	3	3.0	26.83	3	3.1	24.39	3	3.2	21.95
16 3 82	15	4.2	3	3.0	28.57	3	3.0	28.57	3	3.1	26.19
18 3 82	15	4.5	3	2.9	35.56	3	3.0	33.33	3	2.9	35.56
19 3 82	15	4.5	3	2.5	44.44	3	2.7	40.00	3	2.5	44.44
20 3 82	15	4.6	3	2.5	45.65	3	2.7	41.30	3	2.5	45.65
21 3 82	15	4.4	3	1.9	56.82	3	2.4	45.45	3	2.3	47.73
22 3 82	15	3.6	4	1.7	52.78	4	2.2	38.89	4	2.1	41.67
23 3 82	15	4.2	4	1.7	60.71	4	2.4	42.86	4	2.2	48.81
24 3 82	15	3.6	4	1.6	55.56	4	2.2	38.89	4	1.8	50.00
26 3 82	15	3.4	4	1.5	55.88	4	1.9	44.12	4	1.6	52.94
29 3 82	15	3.4	5	1.3	61.76	5	2.1	38.24	5	2.4	29.41
31 3 82	15	4.2	5	1.4	66.67	5	2.3	45.24	5	2.8	33.33
1 4 82	5	4.0	5	1.8	55.00	5	2.8	31.25	5	3.2	20.00
2 4 82	5	4.1	5	1.9	53.66	5	2.8	32.93	5	3.8	7.32
3 4 82	5	3.7	5	2.8	24.32	5	2.6	29.73	5	2.6	29.73
4 4 82	5	4.0	5	2.4	40.00	5	3.0	25.00	5	3.8	5.00
5 4 82	5	3.7	6	2.4	35.14	6	2.9	21.62	6	3.5	5.41
6 4 82	5	3.9	6	2.4	37.18	6	3.0	23.08	6	2.8	28.21
7 4 82	15	3.4	6	2.3	32.35	6	2.8	17.65	6	2.6	23.53
8 4 82	15	3.2	6	2.4	25.00	6	1.8	43.75	6	1.9	40.62
10 4 82	15	2.9	6	1.4	51.72	6	1.1	62.07	6	1.4	51.72
12 4 82	15	2.8	7	1.6	42.86	7	1.1	60.71	7	1.8	35.71
14 4 82	15	2.7	7	1.1	59.26	7	1.2	55.56	7	1.6	40.74
17 4 82	15	3.3	7	1.2	65.71	7	1.9	45.71	7	2.3	34.29
19 4 82	15	4.0	8	2.2	45.00	8	1.8	55.00	8	2.7	32.50
21 4 82	15	5.0	8	2.2	56.00	8	2.3	54.00	8	2.6	48.00
23 4 82	15	4.8	8	2.3	52.08	8	2.4	50.00	8	2.5	47.92
26 4 82	15	4.9	9	2.4	51.02	9	2.3	53.06	9	2.8	42.86
28 4 82	15	4.2	9	2.6	38.10	9	2.2	47.62	9	2.8	33.33
30 4 82	15	5.1	9	2.4	52.94	9	2.4	52.94	9	3.1	39.22
3 5 82	15	4.9	10	2.2	55.10	10	2.3	53.06	10	2.7	44.90
5 5 82	15	5.7	10	2.0	64.91	10	2.3	59.65	0	4.0	29.82
7 5 82	15	4.4	10	2.0	54.55	10	1.8	59.09	0	3.5	20.45
10 5 82	15	4.3	11	1.7	60.47	11	1.5	65.12	1	2.6	39.53
12 5 82	15	4.1	11	1.8	56.10	11	1.5	63.41	1	2.5	39.02
16 5 82	15	4.4	11	1.9	56.82	11	1.6	63.64	2	2.4	45.45
17 5 82	15	5.0	12	2.5	50.00	12	1.4	72.00	2	3.2	36.00
18 5 82	15	5.2	12	2.6	50.00	12	2.4	53.85	2	3.9	25.00

Table G-1. Turbidity Data for Slow Sand Filtration,  
7/1981 - 1/1983 (page 4 of 5)

DATE BY MO YR	TEMP (°C)	INFLUENT TURBIDITY (NTU)	FILTER NO.1 (0.04 m/h)			FILTER NO.2 (0.12 m/h)			FILTER NO.3 (0.40 m/h)		
			SCHMUTZ- DECKE AGE (WEEKS)	EFFLUENT TURBIDITY (NTU)	PERCENT REMOVAL (%)	SCHMUTZ- DECKE AGE (WEEKS)	EFFLUENT TURBIDITY (NTU)	PERCENT REMOVAL (%)	SCHMUTZ- DECKE AGE (WEEKS)	EFFLUENT TURBIDITY (NTU)	PERCENT REMOVAL (%)
19 5 82	15	5.4	12	2.6	51.85	12	2.6	51.85	2	3.4	37.04
20 5 82	15	5.3	12	2.6	50.94	12	2.4	54.72	2	3.9	26.42
21 5 82	15	4.5	12	2.8	37.78	12	2.0	55.56	2	3.5	22.22
22 5 82	15	4.4	12	2.4	45.45	12	2.0	54.55	3	3.5	20.45
23 5 82	15	4.5	12	2.4	46.67	12	1.9	57.78	3	3.4	24.44
24 5 82	15	4.4	13	2.4	45.45	13	2.0	54.55	3	3.5	20.45
25 5 82	5	4.4	13	2.4	45.45	13	2.3	47.73	3	3.3	25.00
26 5 82	5	4.3	13	2.6	39.53	13	2.5	41.86	3	3.4	20.93
27 5 82	5	4.4	13	2.6	40.91	13	2.6	40.91	3	3.4	22.73
28 5 82	5	4.4	13	2.6	40.91	13	2.6	40.91	3	3.6	18.18
29 5 82	5	4.4	13	2.6	40.91	13	2.8	36.36	4	3.6	18.18
1 6 82	15	3.9	14	1.8	53.85	14	2.0	48.72	4	3.1	20.51
2 6 82	15	3.7	14	1.8	51.35	14	1.9	48.65	4	3.0	18.92
3 6 82	15	3.7	14	1.9	48.65	14	2.0	45.95	4	3.1	16.22
4 6 82	15	3.8	14	1.9	50.00	14	2.1	44.74	4	3.0	21.05
6 6 82	15	4.4	0	2.5	43.18	0	4.0	9.09	0	3.5	20.45
7 6 82	15	3.7	0	2.3	37.84	0	4.1	-10.81	0	3.8	-2.70
8 6 82	15	3.8	0	2.7	28.95	0	3.9	-2.63	0	3.7	2.63
9 6 82	15	3.8	1	2.7	28.95	1	3.6	5.26	1	3.5	7.89
10 6 82	15	3.7	1	2.5	32.43	1	3.4	8.11	1	3.3	10.81
11 6 82	15	3.8	1	2.4	36.84	1	3.4	10.53	1	3.1	18.42
12 6 82	15	5.8	1	2.4	58.62	1	3.4	41.38	1	2.9	50.00
15 6 82	15	3.6	1	2.4	33.33	1	2.7	25.00	1	2.6	27.78
17 6 82	15	3.5	2	2.4	31.43	2	2.8	20.00	2	2.6	25.71
20 6 82	15	3.5	2	1.6	54.29	2	2.8	20.00	2	2.6	25.71
21 6 82	15	3.5	2	1.6	54.29	2	3.0	14.29	2	2.8	20.00
22 6 82	15	3.5	2	1.9	45.71	2	3.1	11.43	2	2.9	17.14
23 6 82	15	3.3	3	2.0	39.39	3	3.2	3.03	3	2.8	15.15
24 6 82	15	3.4	3	2.1	38.24	3	3.1	8.82	3	2.6	23.53
25 6 82	15	3.4	3	2.2	35.29	3	3.0	11.76	3	2.6	23.53
28 6 82	15	3.7	3	2.2	40.54	3	2.8	24.32	3	2.7	27.03
30 6 82	15	4.1	4	2.1	48.78	4	2.9	29.27	4	2.8	31.71
2 7 82	15	3.8	4	2.2	42.11	4	2.7	28.95	4	2.7	28.95
4 7 82	5	4.1	0	2.0	51.22	0	3.2	21.95	0	3.0	26.83
5 7 82	5	4.1	0	2.3	43.90	0	3.0	26.83	0	3.1	24.39
6 7 82	5	4.4	0	2.7	38.64	0	3.3	25.00	0	3.2	27.27
7 7 82	5	4.4	1	2.8	36.36	1	3.4	22.73	1	3.4	22.73
8 7 82	5	4.4	1	2.9	34.09	1	3.4	22.73	1	3.3	25.00
9 7 82	5	4.2	1	2.8	33.33	1	3.3	21.43	1	3.3	21.43
12 7 82	15	3.3	1	2.3	30.30	1	2.7	18.18	1	2.4	27.27
14 7 82	15	3.4	2	1.9	44.12	2	2.4	29.41	2	2.6	23.53
16 7 82	15	3.5	2	1.8	48.57	2	2.4	31.43	2	2.3	34.29
18 7 82	5	3.5	2	1.6	54.29	2	2.2	37.14	2	2.3	34.29
19 7 82	5	3.5	2	1.7	51.43	2	2.2	37.14	2	2.3	34.29
20 7 82	5	3.5	2	1.9	45.71	2	2.3	34.29	2	2.4	31.43
21 7 82	5	3.5	3	2.0	42.86	3	2.5	28.57	3	2.5	28.57
22 7 82	5	3.5	3	2.1	40.00	3	2.5	28.57	3	2.6	25.71
23 7 82	5	3.7	3	2.3	37.84	3	2.6	29.73	3	2.6	29.73
25 7 82	15	3.6	3	2.0	44.44	3	2.7	25.00	3	2.8	22.22
26 7 82	15	4.0	3	1.9	52.50	3	2.5	37.50	3	2.4	40.00
28 7 82	15	4.1	4	1.7	58.54	4	2.5	39.02	4	2.3	43.90
29 7 82	15	4.1	4	1.8	56.10	4	2.4	41.46	4	2.3	43.90
30 7 82	15	3.9	4	1.7	56.41	4	2.4	38.46	4	2.3	41.03
1 8 82	15	5.0	4	2.0	60.00	4	2.4	52.00	4	2.3	54.00
2 8 82	15	5.0	4	2.0	60.00	4	2.4	52.00	4	2.6	48.00
3 8 82	15	5.0	4	2.1	58.00	4	2.7	46.00	4	2.8	44.00
4 8 82	15	5.0	5	2.1	58.00	5	2.5	50.00	5	2.7	46.00
5 8 82	15	4.8	5	2.1	56.25	5	2.5	47.92	5	2.8	41.67
6 8 82	15	5.2	5	2.2	57.69	5	2.6	50.00	5	2.9	44.23
8 8 82	15	4.8	5	1.9	60.42	5	2.3	52.08	5	2.6	45.83
9 8 82	15	5.0	5	1.9	62.00	5	2.6	48.00	5	3.0	40.00
10 8 82	15	4.8	5	2.1	56.25	5	2.7	43.75	5	3.1	35.42
11 8 82	15	5.6	6	2.2	60.71	6	2.7	51.79	6	3.0	46.43
12 8 82	15	5.6	6	2.3	58.93	6	2.7	51.79	6	3.2	42.86
13 8 82	15	5.5	6	2.3	58.18	6	2.7	50.91	6	3.2	41.82
16 8 82	15	5.1	6	1.8	64.71	6	2.4	52.94	6	2.9	43.14
18 8 82	15	5.0	7	2.0	60.00	7	2.7	46.00	7	3.2	36.00
20 8 82	15	5.1	7	2.1	58.82	7	2.8	45.10	7	3.3	35.29
24 8 82	15	5.1	7	2.2	56.86	7	2.9	43.14	7	3.4	33.33
27 8 82	15	5.2	8	2.0	61.54	8	2.7	48.08	8	3.4	34.62

Table G-1. Turbidity Data for Slow Sand Filtration,  
7/1981 - 1/1983 (page 5 of 5)

DATE BY MO YR	TEMP (°C)	FILTER NO.1 (0.04 m/h)				FILTER NO.2 (0.12 m/h)				FILTER NO.3 (0.40 m/h)			
		INFLUENT TURBIDITY (NTU)	SCHMUTZ- DECKE AGE (WEEKS)	EFFLUENT TURBIDITY (NTU)	PERCENT REMOVAL (%)	SCHMUTZ- DECKE AGE (WEEKS)	EFFLUENT TURBIDITY (NTU)	PERCENT REMOVAL (%)	SCHMUTZ- DECKE AGE (WEEKS)	EFFLUENT TURBIDITY (NTU)	PERCENT REMOVAL (%)		
31 8 82	15	5.5	8	3.8	30.91	8	3.3	40.00	8	4.5	18.18		
3 9 82	15	6.4	9	3.4	46.87	9	3.6	43.75	9	4.3	32.81		
7 9 82	15	6.5	9	3.2	50.77	9	3.8	41.54	9	4.3	33.85		
10 9 82	15	6.7	10	2.9	56.72	10	3.6	46.27	10	4.5	32.84		
13 9 82	15	6.7	10	2.8	58.21	10	3.6	46.27	10	4.6	31.34		
16 9 82	15	6.9	11	2.8	59.42	11	3.8	44.93	11	4.5	34.78		
18 9 82	15	7.2	11	2.6	63.89	11	4.0	44.44	11	4.7	34.72		
21 9 82	15	7.5	11	2.7	64.00	11	4.1	45.33	11	4.6	38.67		
24 9 82	15	7.6	12	2.6	65.79	12	4.3	43.42	12	4.7	38.16		
28 9 82	15	9.0	12	2.8	68.89	12	4.3	52.22	12	4.2	53.33		
30 9 82	15	7.9	13	3.4	56.96	13	4.7	40.51	13	4.6	41.77		
1 10 82	15	6.9	13	3.7	46.38	13	4.7	31.88	13	4.4	36.23		
2 10 82	15	7.2	13	3.8	47.22	13	4.9	31.94	13	4.5	37.50		
4 10 82	15	7.8	13	3.6	53.85	13	4.6	41.03	13	4.1	47.44		
6 10 82	15	7.4	14	3.7	50.00	14	4.5	39.19	14	3.9	47.30		
7 10 82	15	7.1	14	3.6	49.30	14	4.6	35.21	14	3.9	45.07		
10 10 82	15	7.1	14	3.7	47.89	14	4.7	33.80	14	3.8	46.48		
12 10 82	15	7.3	14	3.5	52.05	14	4.5	38.36	14	3.8	47.95		
14 10 82	15	8.0	15	3.6	55.00	15	4.6	42.50	15	3.8	52.50		
18 10 82	15	7.5	15	3.8	49.33	15	4.8	36.00	15	4.0	46.67		
20 10 82	15	7.8	16	3.8	51.28	16	4.8	38.46	16	4.0	48.72		
21 10 82	15	7.8	16	4.4	43.59	16	5.4	30.77	16	4.6	41.03		
22 10 82	15	7.6	16	4.6	39.47	16	5.6	26.32	16	4.8	36.84		
23 10 82	15	7.6	16	4.7	38.16	16	5.4	28.95	16	4.4	42.11		
24 10 82	15	7.6	16	4.5	40.79	16	5.6	26.32	16	4.7	38.16		
25 10 82	15	7.7	16	4.6	40.26	16	5.5	28.57	16	4.8	37.66		
26 10 82	15	8.4	16	4.9	41.67	16	5.7	32.14	16	4.9	41.67		
27 10 82	15	8.0	17	4.6	42.50	17	5.5	31.25	17	4.8	40.00		
28 10 82	15	8.1	17	4.5	44.44	17	5.6	30.86	17	4.9	39.51		
29 10 82	15	8.2	17	4.6	43.90	17	5.7	30.49	17	4.9	40.24		
30 10 82	15	8.3	17	4.5	45.78	17	5.9	28.92	17	4.9	40.96		
31 10 82	15	8.0	17	4.6	42.50	17	5.9	26.25	17	5.0	37.50		
2 11 82	15	7.8	18	4.7	39.74	18	6.1	21.79	18	5.0	35.90		
3 11 82	15	8.1	0	5.0	38.27	0	7.3	9.88	0	8.0	1.23		
4 11 82	15	8.1	0	5.2	35.80	0	7.8	3.70	0	7.6	6.17		
5 11 82	15	8.9	0	5.8	34.83	0	7.8	12.36	0	7.9	11.24		
6 11 82	15	8.9	1	5.8	34.83	1	8.1	8.99	1	7.2	19.10		
7 11 82	15	9.1	1	6.3	30.77	1	8.3	8.79	1	7.1	21.98		
12 11 82	15	10.9	0	8.1	25.69	0	15.5	-42.20	0	9.7	11.01		
13 11 82	15	10.2	0	8.9	12.75	0	12.9	-26.47	0	10.0	1.96		
14 11 82	15	9.9	0	8.4	15.15	0	11.1	-12.12	0	9.5	4.04		
15 11 82	15	9.6	1	7.8	18.75	1	9.7	-1.04	1	8.8	8.33		
16 11 82	15	9.7	1	7.4	23.71	1	9.7	0.00	1	8.2	15.46		
17 11 82	15	10.2	1	7.1	30.39	1	8.7	14.71	1	7.8	23.53		
18 11 82	15	9.5	1	6.7	29.47	1	8.2	13.68	1	7.2	24.21		
19 11 82	15	10.4	1	6.2	40.38	1	7.8	25.00	1	6.6	36.54		
22 11 82	15	9.7	2	5.4	44.33	2	7.7	20.62	2	5.9	39.18		
24 11 82	15	10.0	2	5.1	49.00	2	7.7	23.00	2	6.0	40.00		
26 11 82	15	9.6	2	5.2	45.83	2	7.6	20.83	2	6.1	36.46		
29 11 82	15	9.8	3	4.8	51.02	3	7.6	22.45	3	6.3	35.71		
1 12 82	15	10.1	3	4.5	55.45	3	7.6	24.75	3	6.3	37.62		
3 12 82	15	10.4	3	4.3	58.65	3	7.6	26.92	3	6.3	39.42		
7 12 82	15	10.7	0	14.5	-35.51	0			4	4.8	55.14		
8 12 82	15	10.6	0	12.6	-18.87	0			4	4.6	56.60		
9 12 82	15	9.5	0	10.9	-14.74	0			4	5.3	44.21		
10 12 82	15	9.5	1	10.8	-13.68	1			4	5.5	42.11		
11 12 82	15	9.8	1	12.3	-25.51	1			4	5.4	44.90		
12 12 82	15	9.8	1	12.9	-31.63	1			4	5.7	41.84		
16 1 83	15	10.1	0	10.8	-6.93	10	7.5	25.74					
19 1 83	15	9.9	0	10.1	-2.02	10	7.9	20.20					
20 1 83	15	9.9	0	10.2	-3.03	10	7.9	20.20					
21 1 83	15	10.0	1	9.2	8.00	10	7.6	24.00					
22 1 83	15	9.6	1	8.9	7.29	10	7.3	23.96					
23 1 83	15	9.2	1	9.1	1.09	10	7.4	19.57					
24 1 83	15	9.7	1	8.9	8.25	11	7.4	23.71					



Table G-2. Statistical summary of turbidity data in Table G-1.

Scope	Calculation	Filter 1 (0.04 m/h)	Filter 2 (0.12 m/h)	Filter 3 (0.40 m/h)
	Number of samples	310	339	304
Calculations include all data in Table G-1	Average influent turbidity (NTU)	6.18	5.96	6.10
	Average effluent turbidity (NTU)	3.96	4.11	4.39
	Average percent removal	35.88	30.98	27.93
	Number of samples	297	297	297
Calculations include only days having data for all three filters	Average influent turbidity (NTU)	6.01	6.01	6.01
	Average effluent turbidity (NTU)	3.66	3.66	3.66
	Average percent removal	39.18	32.14	27.24

Table G-3. Turbidity data for Phase II slow sand filtration testing.

DATE MM DY YR	DAYS OF CONTINUOUS OPERATION (DAYS)	FILTER 1 (CONTROL)			FILTER 2 (1/2 SAND BED)			FILTER 3 (CHLORINATED)			FILTER 4 (NUTRIENTS ADDED)			FILTER 5 (5°C, LARGE SAND)			FILTER 6 (5°C)		
		INFLUENT SFC CONC. (NO/1ML)	EFFLUENT SFC CONC. (NO/1ML)	REMOVAL (%)	EFFLUENT SFC CONC. (NO/1ML)	REMOVAL (%)	EFFLUENT SFC CONC. (NO/1ML)	REMOVAL (%)	EFFLUENT SFC CONC. (NO/1ML)	REMOVAL (%)	EFFLUENT SFC CONC. (NO/1ML)	REMOVAL (%)	EFFLUENT SFC CONC. (NO/1ML)	REMOVAL (%)	EFFLUENT SFC CONC. (NO/1ML)	REMOVAL (%)	EFFLUENT SFC CONC. (NO/1ML)	REMOVAL (%)	
2 9 83	1																		
2 10 83	2	240	3345	-26983.33	3445	-27816.67		14500.0		5150.0	-500.00	330.0	-179.17						
2 11 83	3	1310	65000	-9441.98	67000	-8754.96		4030000.0	-307533.6	1440.0	-533.59	670.0	-16.79						
2 12 83	4	755	125000	-3105.30	116000	-284.11		12000.0	-1489.40	8300.0	-32.45	1530.0	-47.68						
2 13 83	5	74	24200	-41927.02	2900	-31454.05		6000.0	-10710.81	1000.0	-2305.41	1115.0	-2359.46						
2 14 83	6	985	31100	-1752.79	23350	-1158.88				1780.0	-103.55	1820.0	-113.20						
2 15 83	7	3620	18250	-237.02	12400	-551.93				2005.0	26.93	2100.0	38.40						
2 16 83	8	4000	12200		23600					2645.0		2230.0							
2 17 83	9																		
2 20 83	12	3850		29.87		32.47			6.49		66.49		-375.32						
2 21 83	13	365	2700	-664.38	2600	-1050.68		3600.0	-396.63	1290.0	-606.85	18300.0	-1395.89						
2 22 83	14	630	2790	-400.00	4200	-1622.22		1820.0	-376.19	2580.0	-34.92	5460.0	-1685.71						
2 23 83	15	635	3150	.55	10850	-348.82		3000.0	-419.69	410.0	-189.76	11250.0	-366.14						
2 24 83	16	9650	1337	98.45	2850	96.68		3300.0	94.20	1840.0	98.24	2960.0	-41.97						
2 25 83	17		150		320			560.0		170.0		13700.0							
2 27 83	19	1015		-136.45		-81.77			.99		-92.12		-535.47						
2 28 83	20	395	2400	-234.18	1845	-494.94		2040.0	-127.85	1950.0	-307.59	6450.0	-203.80						
3 1 83	21	125	1320	-796.00	2350	-400.00		900.0	-172.00	1610.0	-688.00	1200.0	-5500.00						
3 2 83	22	330	1120	-90.91	625	-59.09		340.0	34.85	985.0	-118.18	7000.0	-104.55						
3 3 83	23	131	630	11.45	525	-83.21		215.0	-83.21	720.0	-331.30	675.0	-640.46						
3 4 83	24		116		240			240.0		585.0		970.0							
3 6 83	26	600		.00		-93.33			-23.33		-83.33		-335.83						
3 7 83	27	43	1500	-7152.87	1160	60.92		740.0	-3371.26	1100.0	-1911.49	2615.0	-157.47						
3 8 83	28	3045	3155	65.19	7900	64.53		1510.0	73.40	875.0	82.27	112.0	96.39						
3 9 83	29	135	1060	-803.70	1080	-207.41		810.0	-288.89	540.0	-137.04	110.0	-307.41						
3 10 83	30	330	1220	-496.97	415	-131.82		525.0	-174.24	320.0	-127.27	550.0	-137.88						
3 11 83	31		1970		765			905.0		750.0		785.0							
3 14 83	34	415		-204.82		-163.86			-15.66		1.20		-63.86						
3 15 83	35	945	1265	-10.05	1095	1.59		480.0	7.41	410.0	21.69	680.0	14.29						
3 16 83	36	975	1040	-53.85	930	-18.46		875.0	-81.03	740.0	29.23	810.0	5.13						
3 17 83	37		1500		1155			1765.0		690.0		925.0							
3 20 83	40	595		-78.99		-10.92			19.33		73.95		15.13						
3 21 83	41	830	1065	-26.51	660	2.41		480.0	-10.84	155.0	53.61	505.0	24.10						
3 22 83	42	9950	1050	90.80	810	93.52		920.0	96.13	385.0	94.97	630.0	93.77						
3 23 83	43	700	915	2.14	645	-22.86		385.0	90.00	500.0	79.29	620.0	60.00						
3 24 83	44	775	685	-45.81	860	.65		70.0	-222.58	145.0	54.84	280.0	60.00						
3 25 83	45		1130		770			2500.0		350.0		310.0							
3 27 83	47	850		11.18		27.65			40.59		48.82		40.00						
3 28 83	48	340	755	-76.47	615	-108.82		505.0	22.06	435.0	57.35	510.0	7.35						

(CONTINUED)

Table G-3. (continued).

DATE	IN DY	YR	DAYS OF CONTINUOUS OPERATION (DAYS)	(CONTROL) FILTER 1			(1/2 SAND BED) FILTER 2			(CHLORINATED) FILTER 3			(NUTRIENTS ADDED) FILTER 4			(5°C, LARGE SAND) FILTER 5			(5°C) FILTER 6				
				EFFLUENT SPC CONC. (NO./ML.)	REMOVAL (%)	SPC CONC. (NO./ML.)	EFFLUENT SPC CONC. (NO./ML.)	REMOVAL (%)	SPC CONC. (NO./ML.)	EFFLUENT SPC CONC. (NO./ML.)	REMOVAL (%)	SPC CONC. (NO./ML.)	EFFLUENT SPC CONC. (NO./ML.)	REMOVAL (%)	SPC CONC. (NO./ML.)	EFFLUENT SPC CONC. (NO./ML.)	REMOVAL (%)	SPC CONC. (NO./ML.)	EFFLUENT SPC CONC. (NO./ML.)	REMOVAL (%)	SPC CONC. (NO./ML.)	EFFLUENT SPC CONC. (NO./ML.)	REMOVAL (%)
3 29 83			49	600	96.56	710	95.73	47.92	265.0	96.41	145.0	82.29	315.0										
4 5 83			56	19200	31.53	820	13.38	-1049.68	690.0	48.41	3400.0	-154.78	2400.0									87.50	
4 6 83			57	1570	67.04	840	53.07	-1257.54	810.0	82.96	4000.0	72.63	4200.0									-167.52	
4 7 83			58	1075	59.00	455	40.65		305.0	53.62	490.0	96.38	700.0									60.89	
4 8 83			59	590	46.45	460	-29.82		320.0	24.52	25.0	85.81	15.0									97.83	
4 11 83			62	345	-43.86	370			505.0	-163.16	110.0	82.46	60.0									92.26	
4 12 83			63	415					750.0		50.0											75.44	
4 13 83			64	410																			
4 14 83			65																				
4 16 83			67																				
4 21 83			72																				
4 22 83			73																				
4 25 83			76	1555	78.46	325	79.10		140.0	91.00	80.0	94.86	45.0									97.11	
4 26 83			77	1375	88.36	155	88.73		85.0	93.82	150.0	89.09	45.0									90.91	
4 27 83			78	2285	80.96	405	82.28		91.0	96.02	103.0	95.49	33.0									98.56	
4 28 83			79																				
5 3 83			84																				
5 4 83			85																				
5 15 83			96																				
5 16 83			97	1460	64.73	60	54.45	51.37	310.0	78.77	215.0	85.27	20.0									93.84	
5 17 83			98	755	48.34	665	19.21	-3.31	100.0	86.75	260.0	65.56	90.0									92.72	
5 18 83			99	840	2.98	610	25.00	-334.52	180.0	51.19	260.0	68.45	55.0									88.69	
5 19 83			100	965	98.45	630	93.78	-184.97	3650.0	97.93	265.0	83.94	95.0									97.93	
5 20 83			101	15		60		2750.0	20.0		155.0		20.0										
5 23 83			104	1145	51.53	625	86.90	68.56	345.0	89.08	70.0	86.46	245.0									94.32	
5 24 83			105	820	-19.51	150	60.98	62.20	125.0	78.05	155.0	90.85	65.0									93.29	
5 25 83			106	390	-146.15	320	-19.23	-143.59	180.0	33.33	75.0	44.87	55.0									83.33	
5 26 83			107	670	-88.81	465	6.72	-474.63	260.0	48.51	215.0	89.55	65.0									63.43	
5 27 83			108	1265		625		3850.0	345.0														
5 30 83			111	680	14.71	300	55.88	85.29	460.0	69.85	245.0	92.65	245.0									94.85	
5 31 83			112	710	-35.92	300	42.96	-38.03	205.0	35.21	50.0	79.58	35.0									85.21	
6 1 83			113	630	-30.16	405	50.79	-134.92	460.0	33.33	145.0	89.68	105.0									94.44	
6 2 83			114	820		310		1480.0	420.0		65.0		35.0										
6 27 83			139	515	-73.79	775	-50.49	-1.94	255.0	50.49	425.0	17.48	59.22										
6 28 83			140	660	-47.73	450	31.82	-131.82	185.0	71.97	170.0	74.24	210.0									85.61	
6 29 83			141	655	-16.03	215	67.18	-252.67	115.0	82.44	35.0	94.66	95.0									97.71	
6 30 83			142	420	-76.19	300	28.57	-744.05	110.0	73.81	100.0	76.19	95.0									77.38	
7 1 83			143	740		295	-31.70	75.45	160.0	28.57	60.0	73.21	50.0									77.68	
7 4 83			146		-158.93		-45.16	-500.00		29.03		83.87											90.32
7 5 83			147	580	9.68	295																	

(CONTINUED)

Table G-3. (continued).

DATE M: DY YR	DAYS OF CONTINUOUS OPERATION (DAYS)	FILTER 1 (CONTRCL.)			FILTER 2 (1/2 SAND BED)			FILTER 3 (OIL/UNTMTD)			FILTER 4 (NUTRIENTS ADDED)			FILTER 5 (5°C, LARGE SAND)			FILTER 6 (5°C)		
		INFLUENT SFC CONC. (NO/1ML)	EFFLUENT SFC CONC. (NO/1ML)	REMOVAL (%)	EFFLUENT SFC CONC. (NO/1ML)	REMOVAL (%)	EFFLUENT SFC CONC. (NO/1ML)	REMOVAL (%)	EFFLUENT SFC CONC. (NO/1ML)	REMOVAL (%)	EFFLUENT SFC CONC. (NO/1ML)	REMOVAL (%)	EFFLUENT SFC CONC. (NO/1ML)	REMOVAL (%)	EFFLUENT SFC CONC. (NO/1ML)	REMOVAL (%)	EFFLUENT SFC CONC. (NO/1ML)	REMOVAL (%)	
7 6 83	148	150	140	-400.00	225	.00	930.00	-1030.00	110.0	-396.67	25.0	60.00	15.0	46.67					
7 7 83	149	515	750	21.36	360	42.72	1695.0	-503.88	745.0	75.73	60.0	90.06	80.0	91.26					
7 8 83	150		405		295		3110.0		125.0		10.0		45.0						
7 11 83	153	3000		78.83		94.00		74.00		97.50		97.83		98.67					
7 12 83	154		635	88.21	180	48.21	780.0	-526.79	75.0	80.36	65.0	82.14	40.0	73.21					
7 13 83	155	190	33	-171.05	145	-13.16	1755.0	-125.79	55.0	52.63	50.0	86.84	75.0	92.11					
7 14 83	156	160	515	-306.25	215	-53.13	429.0	-2612.50	90.0	-587.50	25.0	3.13	15.0	43.75					
7 15 83	157	490	650		245		4340.0		1100.0		155.0		90.0						
7 18 83	160	320		-84.38		31.25		73.44		40.63		32.81		48.44					
7 19 83	161	345	590	-71.01	220	23.19	85.0	.29	190.0	40.58	215.0	13.04	165.0	40.58					
7 20 83	162	340	590	-79.41	265	23.53	760.0	-344.12	205.0	83.82	300.0	70.59	205.0	83.82					
7 21 83	163	180	610	-163.89	260	-27.78	1510.0	3.33	55.0	2.78	100.0	-122.22	55.0	19.44					
7 22 83	164	130	475		230		174.0		175.0		400.0		145.0						
7 23 83	165																		
7 24 83	166	350		-51.43		65.71		35.71		57.14		75.71		68.57					
7 25 83	167	307	530	-49.04	120	49.51	225.0	-183.39	150.0	70.68	85.0	75.57	110.0	73.94					
7 26 83	168	325	460	.00	155	44.62	870.0	-203.08	90.0	69.23	75.0	70.77	80.0	86.15					
7 27 83	169	485	715	7.22	180	84.54	905.0	51.55	100.0	79.38	95.0	94.85	45.0	90.72					
7 28 83	170	205	450	-195.12	75		235.0		100.0	73.17	25.0	51.22	45.0	78.05					
7 29 83	171		605		205				55.0		100.0		45.0						
8 1 83	174	290		-62.07		32.76		-56.90		70.69	.00	.00		10.34					
8 2 83	175	365	470	1.37	195	58.90	455.0	-138.36	85.0	75.34	580.0	94.52	260.0	87.67					
8 3 83	176	320	360	-47.19	150	23.44	870.0	-307.81	90.0	78.13	20.0	60.94	45.0	79.69					
8 4 83	177	370	471	-10.81	245	52.70	1305.0	-1486.49	70.0	86.49	125.0	62.16	65.0	77.03					
8 5 83	178		410		175		5870.0		50.0		140.0		85.0						
8 8 83	181	1480		93.92		90.54		62.16		98.99		93.92		92.57					
8 9 83	182	1870	90	90.64	140	84.49	560.0	-31.55	15.0	98.66	90.0	78.61	110.0	95.19					
8 10 83	183	3760	175	89.63	290	92.82	2460.0	89.71	25.0	90.96	400.0	89.76	90.0	98.27					
8 11 83	184	1055	390	61.61	270	78.67	387.0	-144.55	340.0	72.04	385.0	55.92	65.0	86.26					
8 12 83	185		405		225		2580.0		295.0		465.0		145.0						

Table G-4. Statistical summary of standard plate count bacteria data in Table G-3.

		Filter 1	Filter 2	Filter 3	Filter 4	Filter 5	Filter 6
All Available Data	Number of Samples	80	80	42	78	80	80
	Geometric Average Influent Concentration (No./mL)	624	624	595	628	624	624
	Geometric Average Effluent Concentration (No./mL)	825	604	1075	352	249	223
	Average Percent Removal (%)	-32	3	-80	44	60	64
Established Operation	Number of Samples	24	24	23	24	24	24
	Geometric Average Influent Concentration (No./mL)	371	371	380	371	371	371
	Geometric Average Effluent Concentration (No./mL)	524	240	719	156	80	62
	Average Percent Removal (%)	-41	35	-89	58	78	83

Table G-5. Turbidity data for Phase III slow sand filtration testing.

DATE MN DY YR	DAYS OF CONTINUOUS OPERATION (DAYS)	INFLUENT		FILTER 1 (CONTROL)		FILTER 2 (DE. COATED)		FILTER 3 (SMALL SAND)		FILTER 4 (CONTROL)		FILTER 5 (LARGE SAND)		FILTER 6 (2 C)	
		SFC CONC. (NO./IHL)	REMOVAL (%)	SFC CONC. (NO./IHL)	REMOVAL (%)	SFC CONC. (NO./IHL)	REMOVAL (%)	SFC CONC. (NO./IHL)	REMOVAL (%)	SFC CONC. (NO./IHL)	REMOVAL (%)	SFC CONC. (NO./IHL)	REMOVAL (%)	SFC CONC. (NO./IHL)	REMOVAL (%)
8 15 83	188	1080	81.94	195	81.94	41.20	70.00	324.0	88.89	120.0	88.89	57.0	94.72	60.0	94.44
8 16 83	189	1360	90.81	125	90.81	69.49	44.85	750.0	98.16	25.0	98.16	120.0	91.18	50.0	96.32
8 17 83	190	835	71.86	235	71.86	-65.27	-101.80	1685.0	83.23	140.0	83.23	410.0	50.90	65.0	92.22
8 18 83	191	1085	86.64	145	86.64	86.18	16.59	905.0	88.02	130.0	88.02	110.0	89.86	50.0	95.39
8 23 83	196	99	-71.72	170	-71.72	9.09	-187.88	285.0	-11.11	110.0	-11.11	315.0	-218.18	45.0	54.55
8 24 83	197	720	80.56	140	80.56	76.39	-1.39	730.0	85.42	105.0	85.42	115.0	84.03	65.0	90.97
8 25 83	198					170									
8 29 83	202	790	96.84	25	96.84	91.14	48.10	410.0	84.18	125.0	84.18	95.0	87.97	55.0	93.04
8 30 83	203	990	88.89	110	88.89	80.81	41.92	575.0	86.36	135.0	86.36	102.0	89.70	65.0	91.43
9 1 83	204					190									
9 5 83	208	1025	91.71	85	91.71	80.88	77.07	235.0	95.61	45.0	95.61	70.0	93.17	45.0	95.61
9 6 83	209	795	85.79	113	85.79	85.79	62.89	295.0	90.57	75.0	90.57	145.0	81.76	77.0	90.31
9 7 83	210	790				152									
9 26 83	229	3140	95.86	130	95.86	94.43	84.08	500.0	96.50	110.0	96.50	150.0	95.22	26.0	99.17
9 27 83	230	1225	88.49	141	88.49	90.20	62.06	455.0	86.29	168.0	86.29	184.0	84.98	60.0	95.10
9 28 83	231	1085	96.31	40	96.31	97.05	68.66	340.0	92.63	80.0	92.63	300.0	72.35	32.0	97.05
9 29 83	232					32									
9 30 83	233														
10 11 83	245	365	72.33	86	72.33	79.45	15.07	258.0	75.89	115.0	75.89	330.0	24.11	20.0	92.05
10 12 83	246	584	80.48	101	80.48	72.09	41.95	310.0	32.53	88.0	32.53	277.0	52.05	29.0	91.61
10 13 83	247	415	75.66	114	75.66	77.11	28.67	339.0	31.08	394.0	31.08	280.0	69.40	49.0	88.92
10 14 83	248	268	69.78	101	69.78	64.93	-42.16	296.0	-35.07	206.0	-35.07	127.0	-2.61	46.0	95.52
10 15 83	249	172	59.30	81	59.30	79.65	-116.28	381.0	48.84	362.0	48.84	275.0	-44.19	12.0	90.12
10 16 83	250	118	27.12	70	27.12	29.66	-196.61	372.0	-191.53	88.0	-191.53	248.0	-129.66	17.0	81.36
10 17 83	251	120	10.42	86	10.42	60.42	-168.75	350.0	-19.79	344.0	-19.79	271.0	-243.75	22.0	79.17
10 26 83	260	96													
10 27 83	261	56													
11 5 83	270	8	-1293.26	86	-1293.26	-1091.01	-3225.84	258.0	-1877.53	115.0	-1877.53	330.0	-3641.57	20.0	-23.60
11 6 83	271	67	14.93	124	14.93	16.42	-273.13	296.0	-113.43	176.0	-113.43	333.0	-232.84	11.0	91.04
11 7 83	272	418	63.64	57	63.64	80.62	-36.36	250.0	44.02	143.0	44.02	223.0	2.39	6.0	95.69
11 8 83	273	93	-58.06	152	-58.06	-13.98	-345.16	570.0	-193.55	234.0	-193.55	408.0	-220.43	18.0	89.25
11 9 83	274	62	-27.42	147	-27.42	53.23	-153.23	414.0	-88.71	273.0	-88.71	298.0	-208.06	10.0	93.55
11 10 83	275	52		79				157.0		117.0		191.0		4.0	
11 13 83	278	13	-515.38	80	-515.38	-3315.38	-3407.69	444.0	-1984.62	271.0	-1984.62	373.0	-2769.23	19.0	-46.15
11 14 83	279	13	-384.62	80	-384.62	-3407.69	-3407.69	444.0	-1569.23	271.0	-1569.23	373.0	-1830.77	19.0	-112.50
11 15 83	280	8	-1250.00	63	-1250.00	456.0	-5925.00	456.0	-2875.00	217.0	-2875.00	251.0	-3300.00	13.0	-157.14
11 16 83	281	7	-2714.29	108	-2714.29	482.0	-5728.57	482.0	-4128.57	238.0	-4128.57	272.0	-5085.71	18.0	-142.86
11 17 83	282	7	-1585.71	197	-1585.71	408.0		408.0	-3871.43	296.0	-3871.43	382.0	-5085.71	18.0	-142.86
11 18 83	283	7	-1257.14	118	-1257.14				-2971.43	278.0	-2971.43	363.0	-4028.57	17.0	-171.43

(CONTINUED)

Table G-5. (continued).

DATE FN DY YR	DAYS OF CONTINUOUS OPERATION (DAYS)	INFLUENT SPC CONC. (NO./LML)	FILTER 1 (CONTROL)		FILTER 2 (DE. COATED)		FILTER 3 (SMALL SAND)		FILTER 4 (CONTROL)		FILTER 5 (LARGE SAND)		FILTER 6 (2°C)	
			EFFLUENT SPC CONC. (NO./LML)	REMOVAL (%)	EFFLUENT SPC CONC. (NO./LML)	REMOVAL (%)	EFFLUENT SPC CONC. (NO./LML)	REMOVAL (%)	EFFLUENT SPC CONC. (NO./LML)	REMOVAL (%)	EFFLUENT SPC CONC. (NO./LML)	REMOVAL (%)	EFFLUENT SPC CONC. (NO./LML)	REMOVAL (%)
11 19 83	284	5	95	-1580.00					215.0	-4280.00	289.0	-6000.00	19.0	-300.00
11 20 83	285	4	84	-3000.00					219.0	-7025.00	305.0	-8100.00	20.0	-275.00
11 21 83	286	173500	124	99.82			98.39		285.0	99.89	328.0	99.77	15.0	71.18
11 22 83	287	205000	315	99.76			99.24		195.0	99.76	405.0	99.61	50000.0	89.35
11 23 83	288	630000	500	99.95			99.66		485.0	99.90	805.0	99.86	21830.0	89.44
11 24 83	289	525000	300	99.94			99.64		620.0	99.94	885.0	99.82	66500.0	93.90
11 25 83	290	130000	315	99.60			97.15		1900.0	99.64	970.0	99.46	32000.0	46.54
11 26 83	291	108000	520	99.84			99.25		470.0	99.82	700.0	99.66	69500.0	87.45
11 27 83	292	1385000	175	99.97			810.0		195.0	99.98	370.0	99.94	13550.0	93.21
11 28 83	293	1510000	410	99.87			1280.0		325.0	99.97	795.0	99.77	94000.0	96.36
11 29 83	294	1145000	1910	99.95			2100.0		510.0	99.95	3535.0	99.76	55000.0	92.62
11 30 83	295	1310000	580	99.93			2800.0		575.0	99.96	2785.0	99.77	84500.0	96.37
12 1 83	296		870				2050.0		495.0		2985.0		47500.0	
12 14 83	309	115		-5.65			8.70			20.00		-24.35		76.96
12 15 83	310	101	121	-16.26			-52.71		92.0	-6.40	143.0	-74.88	26.5	49.26
12 16 83	311	201	118	49.25			54.23		108.0	42.04	177.5		51.5	68.91
12 17 83	312	121	102	16.12			-17.36		116.5	-7.02	201.0	-62.81	62.5	64.46
12 18 83	313	143	101	26.57			27.97		129.5	33.22	197.0	-35	43.0	76.92
12 19 83	314	89	105	12.85			-29.05		95.5	-11.73	143.5	-35.20	33.0	71.51
12 20 83	315	114	78	31.00			-4.37		100.0	9.17	121.0	1.75	25.5	85.15
12 21 83	316	87	79	6.32			-41.38		104.0	-16.09	112.5	-31.61	17.0	73.56
12 22 83	317	125	81	8.76			3.19		101.0	1.99	114.5	-31.87	23.0	65.74
12 23 83	318		114				121.5		123.0		165.5		43.0	

Table G-6. Statistical summary of turbidity data in Table G-5.

		Filter 1	Filter 2	Filter 3	Filter 4	Filter 5	Filter 6
All Available Data	Number of Samples	44	17	43	44	44	44
	Geometric Average Influent Concentration (No/ml)	7.2	7.8	7.2	7.2	7.2	7.2
	Geometric Average Effluent Concentration (No/ml)	6.3	6.4	9.0	6.7	6.2	6.1
	Average Percent Removal (%)	12.2	18.0	-25.8	6.7	12.8	14.2
Established Operation	Number of Samples	9	7	9	9	9	9
	Geometric Average Influent Concentration (No/ml)	5.3	7.4	5.3	5.3	5.3	5.3
	Geometric Average Effluent Concentration (No/ml)	4.5	6.7	4.5	5.3	4.7	4.2
	Average Percent Removal (%)	15.8	9.1	15.4	0.6	11.6	21.4



## APPENDIX H

### Particle Count Data for Slow Sand Filtration 2/1982 - 6/1982

Table H-1 contains the results of particle counting for the period February 1982 to June 1982. Particle counting was done with a Coulter Counter, Model TA II. The operating protocol for this instrument is given in Appendix N. Table H-1 shows the influent and effluent particle data, as in Tables A-1, A-2, and A-3, Appendix A, as well as daily removal percentages. These removals have been calculated using the influent value from the previous day to account for residence time in the filter.

Table H-2 is a statistical summary of the particle count data of Table H-1. It contains the total number of sample analyzed, the average influent and effluent particle concentrations, and the average removal percentage achieved by each filter.

Table H-1. Particle count data for slow sand filtration, 2/1982 - 6/1982  
(page 1 of 1).

DATE BY MO YR	TEMP (°C)	FILTER NO.1 (0.04 m/h)			FILTER NO.2 (0.12 m/h)			FILTER NO.3 (0.40 m/h)			
		INFLUENT PARTICLES (NO/10ML)	SCHMUTZ- DECKE AGE (WEEKS)	EFFLUENT PARTICLES (NO/10ML)	PERCENT REMOVAL (%)	SCHMUTZ- DECKE AGE (WEEKS)	EFFLUENT PARTICLES (NO/10ML)	PERCENT REMOVAL (%)	SCHMUTZ- DECKE AGE (WEEKS)	EFFLUENT PARTICLES (NO/10ML)	PERCENT REMOVAL (%)
26 2 82	5	1769.0									
27 2 82	5	1609.0	0	112.0	93.67	0	290.0	83.61	0	151.0	91.46
28 2 82	5	1720.0	0	208.0	87.07	0	89.0	94.47	0	116.0	92.79
1 3 82	5		1	252.0	85.35	1	81.0	95.29	1	41.0	97.62
2 3 82	5	922.0									
3 3 82	5	831.0	1	112.0	87.85	1	43.0	95.34	1	64.0	93.06
18 3 82	15	1294.0									
19 3 82	15	40506.0	3	308.0	76.20	3	88.0	93.20	3	31.0	97.60
20 3 82	15	12591.0	3	100.0	99.75	3	38.0	99.91	3	40.0	99.90
21 3 82	15	7975.0	3	206.0	98.36	3	60.0	99.52	3	38.0	99.54
22 3 82	15	553.0	4	109.0	98.63	4	75.0	99.06	4	54.0	99.32
23 3 82	15	62.0	4	104.0	81.19	4	55.0	90.05	4	329.0	40.51
1 4 82	5	5811.0									
2 4 82	5	1500.0	5	241.0	95.85	5	135.0	97.68	5	63.0	98.92
3 4 82	5	1697.0	5	172.0	88.53	5	86.0	94.27	5	61.0	95.93
4 4 82	5										
5 4 82	5	198.0	6	70.0		6	31.0		6	30.0	
6 4 82	5		6	90.0	54.55	6	74.0	62.63	6	47.0	76.26
27 5 82	5	1150.0	13	662.0		13	226.0		3	533.0	
28 5 82	5	935.0	13	314.0	72.70	13	48.0	95.83	3	440.0	61.74
2 6 82	15	1462.0	14	535.0		14	4402.0		4	472.0	
7 6 82	15	426.0	0	261.0		0	276.0		0	137.0	
10 6 82	15	422.0	1	186.0		1	78.0		1	172.0	
21 6 82	15	497.0	2	584.0		2	85.0		2	200.0	

NOTE: REMOVALS ARE CALCULATED WITH THE INFLUENT FROM THE PREVIOUS DAY TO ACCOUNT FOR RESIDENCE TIME IN THE FILTER

Table H-2. Statistical summary of particle count data in Table H-1.

Calculation	Filter 1 (0.04 m/h)	Filter 2 (0.12 m/h)	Filter 3 (0.40 m/h)
Number of samples	13	13	13
Average influent conc. (no./10ml)	6013.5	6013.5	6013.5
Average effluent conc. (no./10ml)	179.1	89.4	115.0
Average percent removal	97.02	98.51	98.09

Note: Data was available for all three filters every day that particle counting was performed, therefore, only one method of calculation was necessary.

## APPENDIX I

### Graphical Operating Histories for Temperature, Headloss, and Hydraulic Loading Rate 7/1981 - 1/1983

The nine figures that follow contain graphical histories of hydraulic loading rate, temperature, and headloss. These figures can be cross-referenced by date with any of the tables in Appendices A-H. They are arranged by filter number and phase, with graphs for filters 1, 2, and 3 of Phase I given first. The graphs for the six Phase II and Phase III are given next.

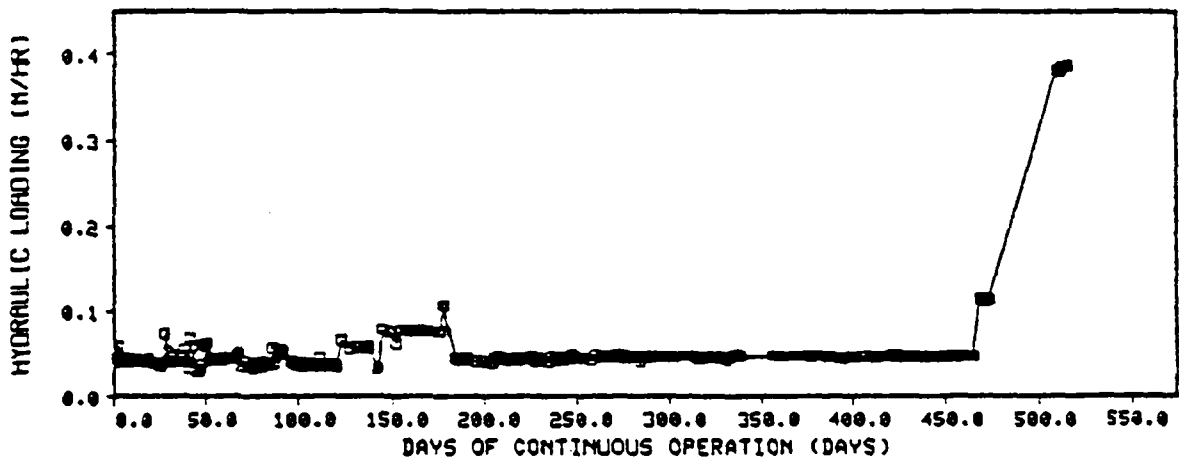
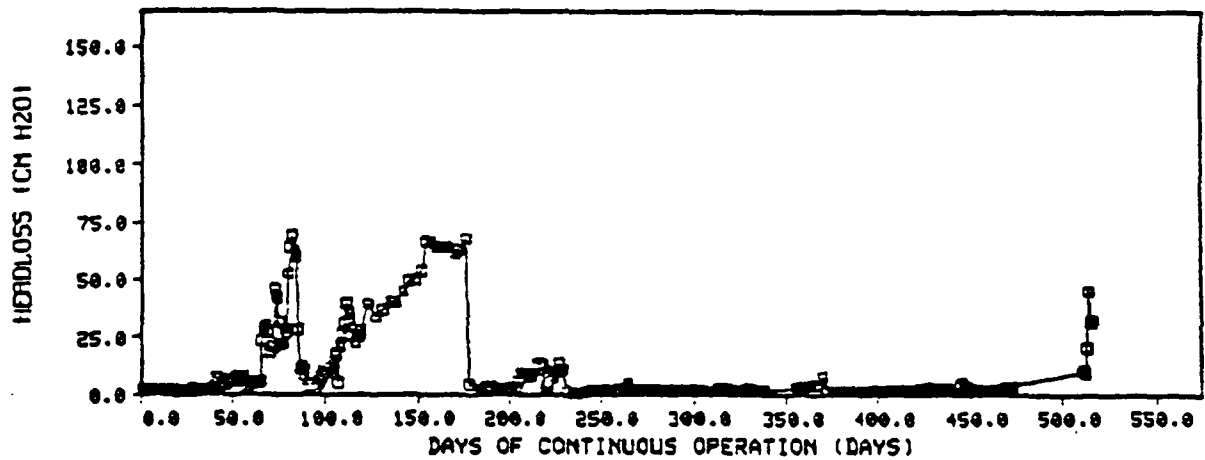
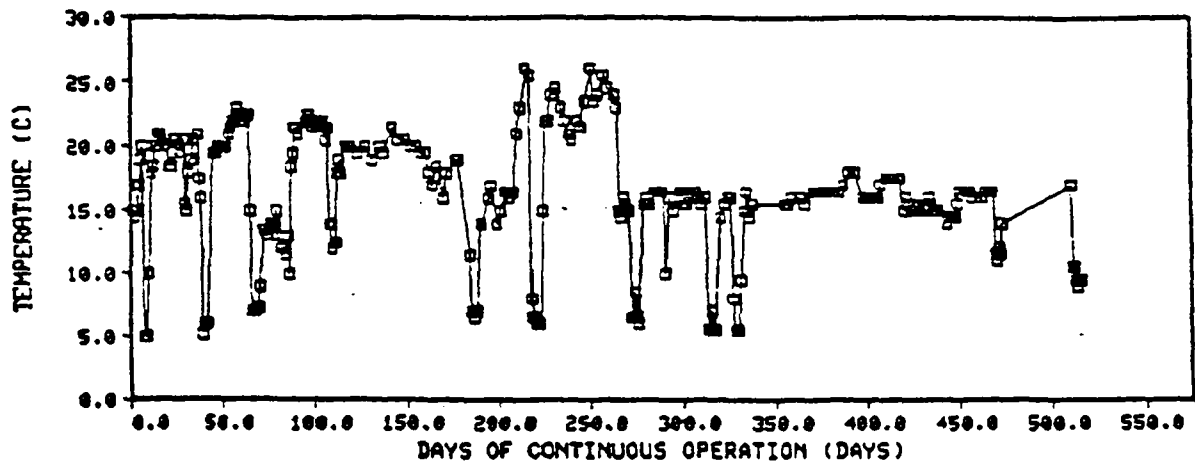

Figure I-1. Graphical operating history of temperature, headloss and hydraulic loading rate for Filter 1 Phase I operation.

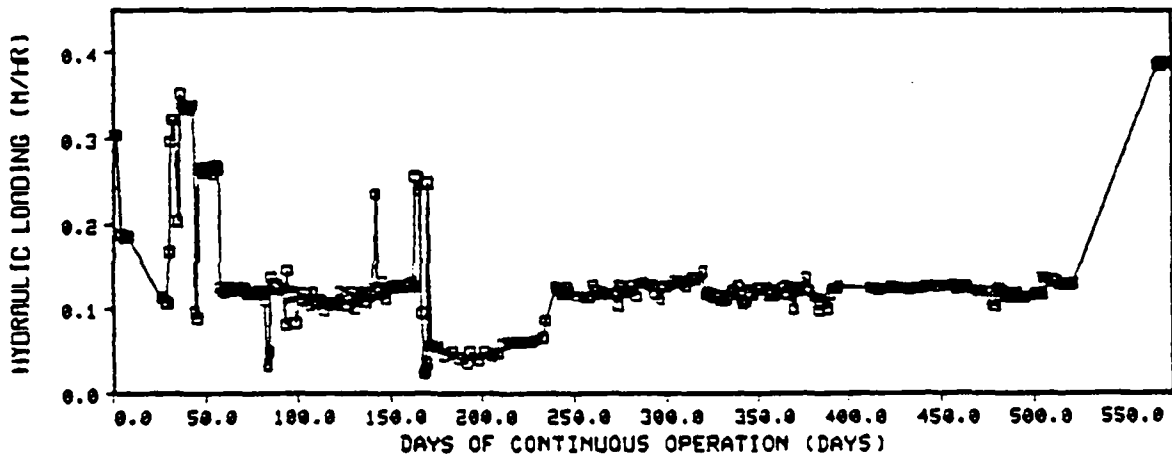
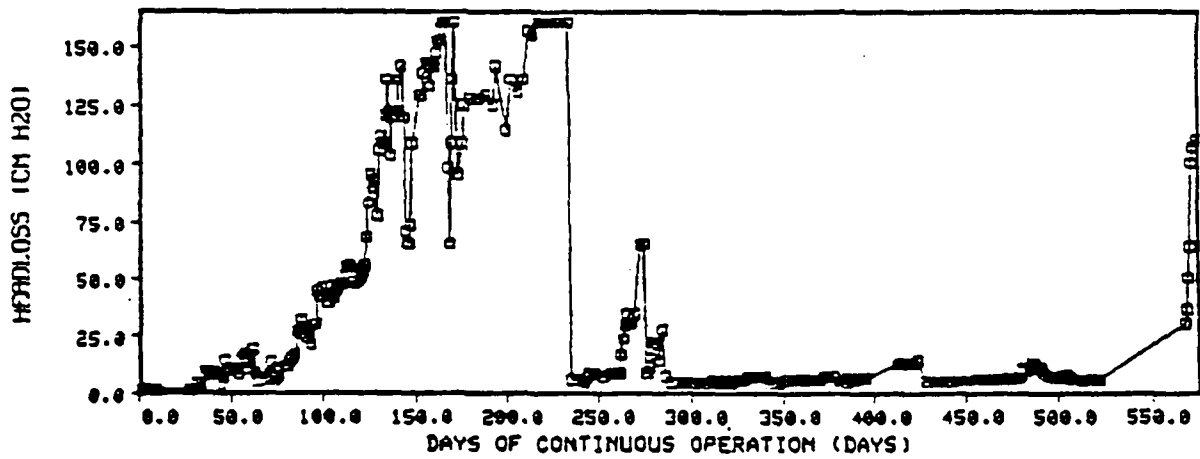
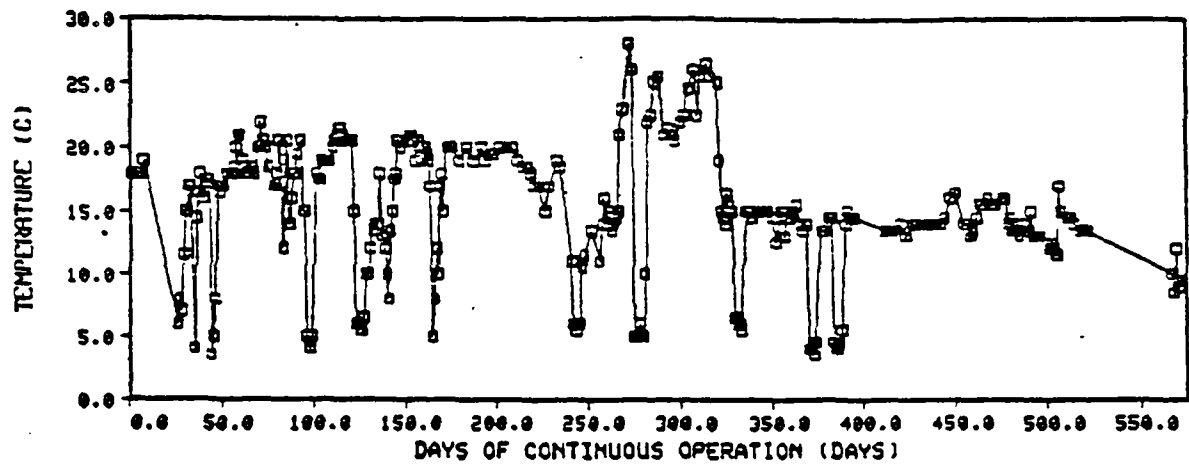

Figure I-2. Graphical operating history of temperature, headloss and hydraulic loading rate for Filter 2 Phase I operation.

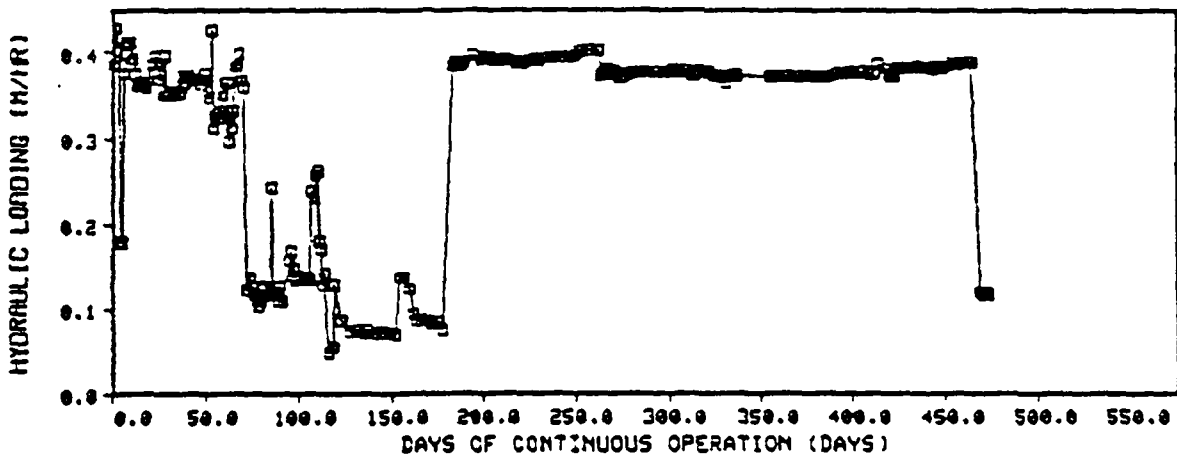
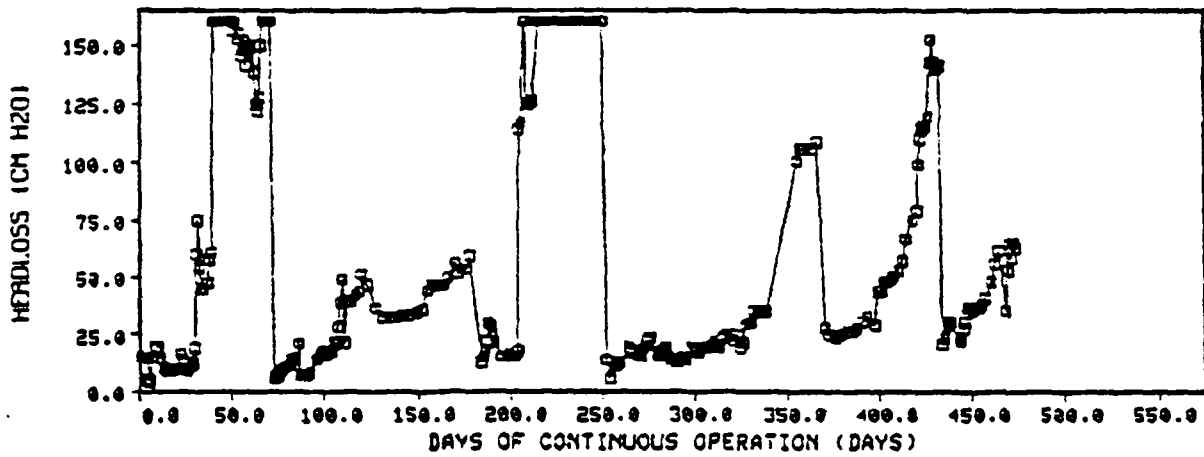
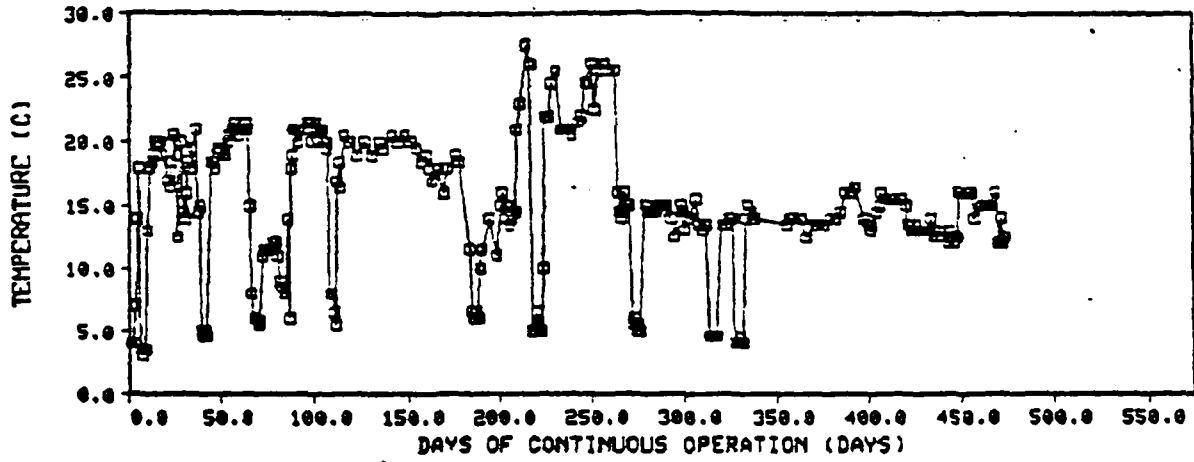

Figure I-3. Graphical operating history of temperature, headloss and hydraulic loading rate for Filter 3 Phase I operation.

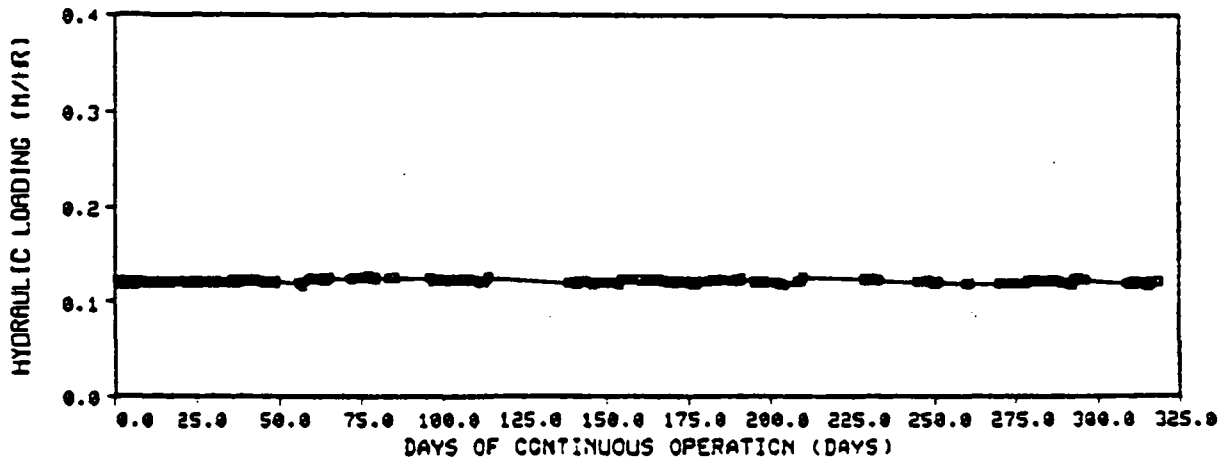
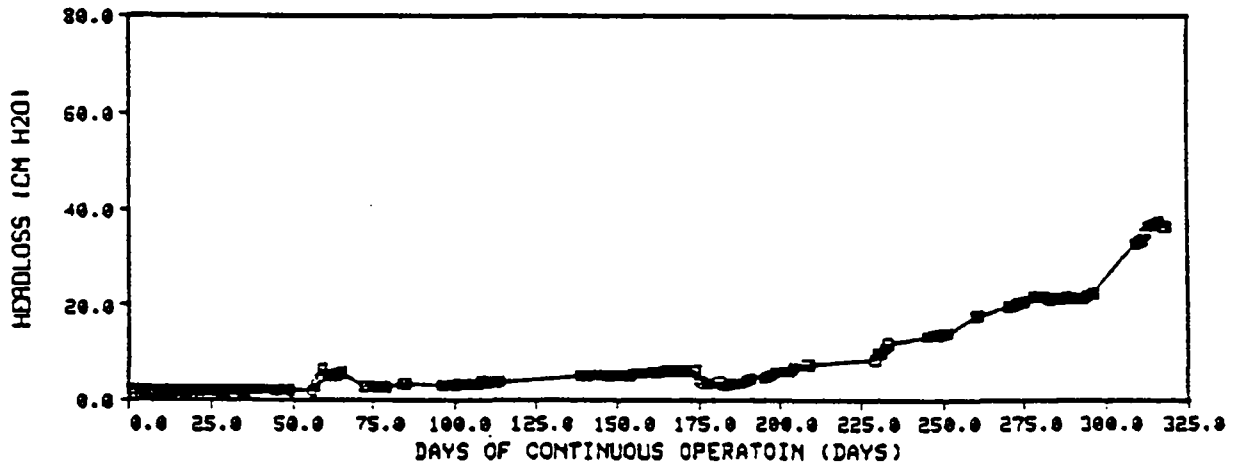
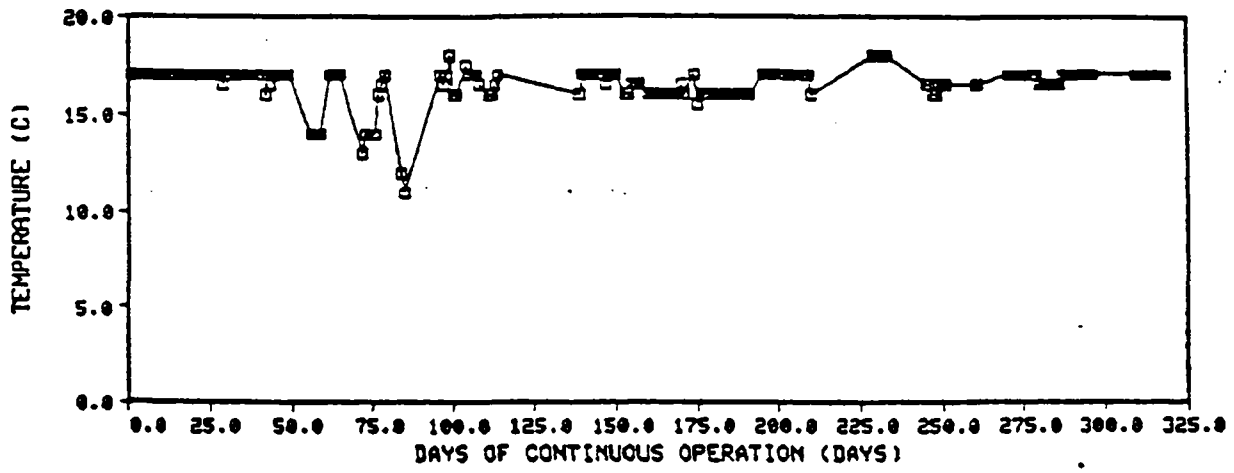

Figure I-4. Graphical operating history of temperature, headloss and hydraulic loading rate for Filter 1 Phase II and Phase III operation.



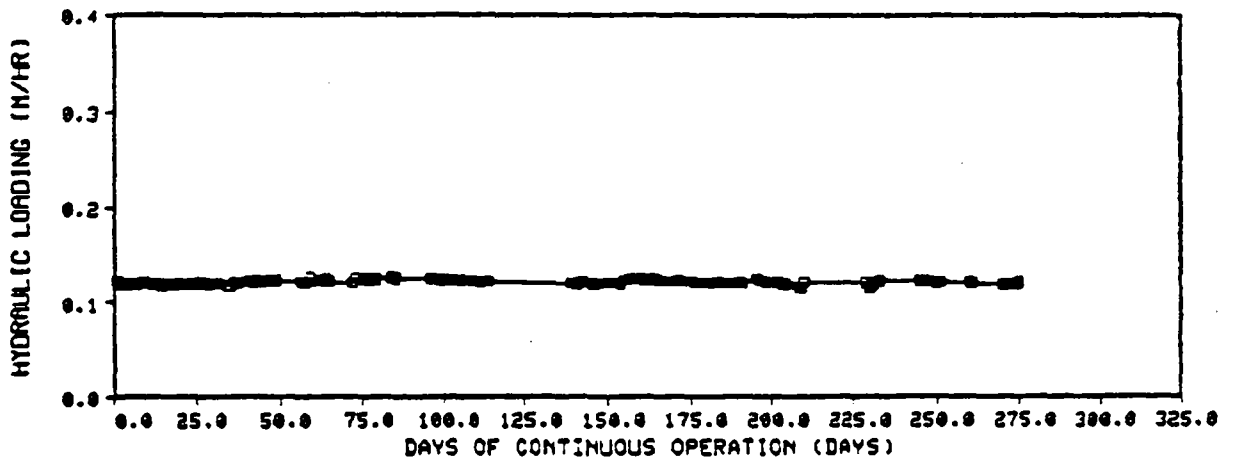
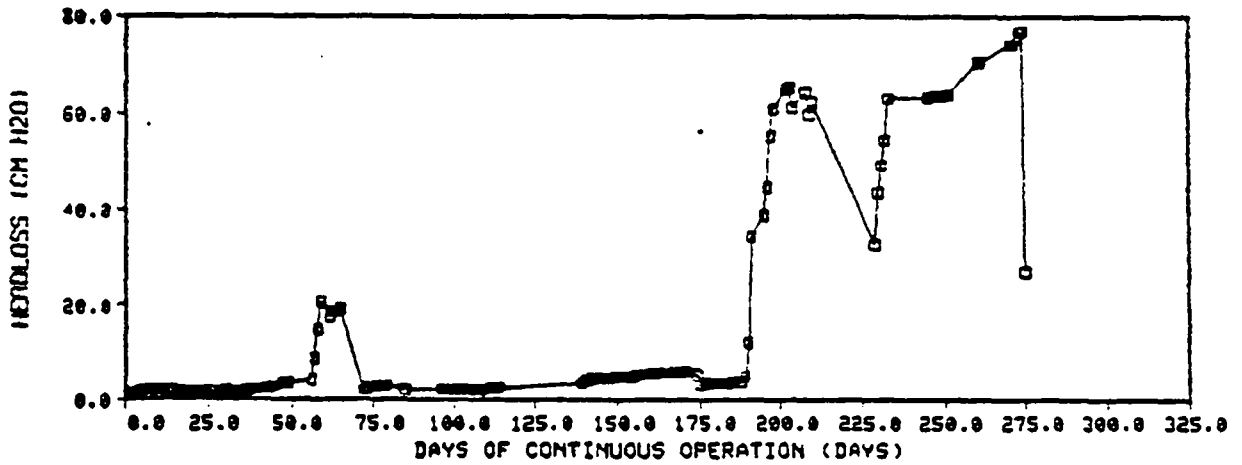
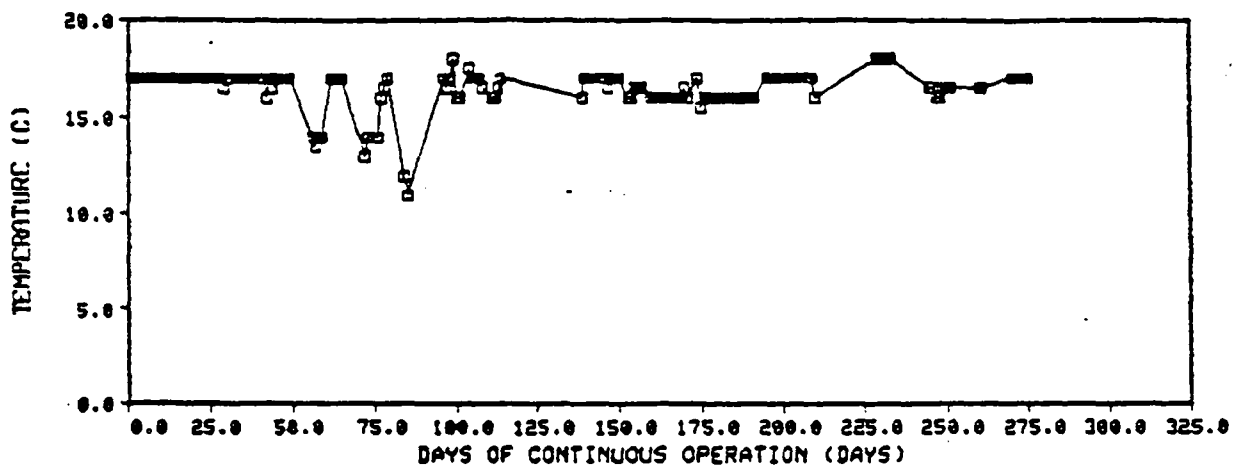

Figure I-5. Graphical operating history of temperature, headloss and hydraulic loading rate for Filter 2 Phase II and Phase III operation.

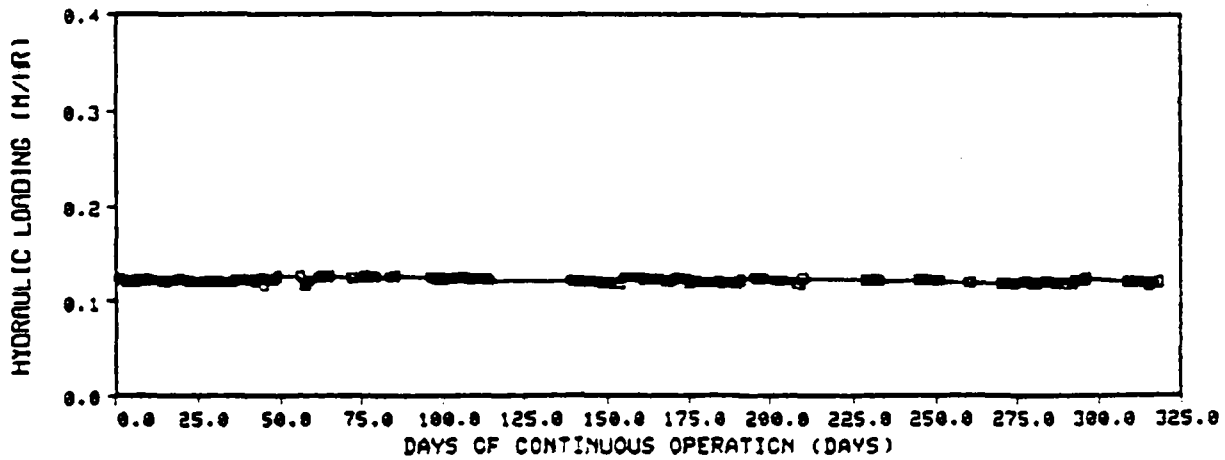
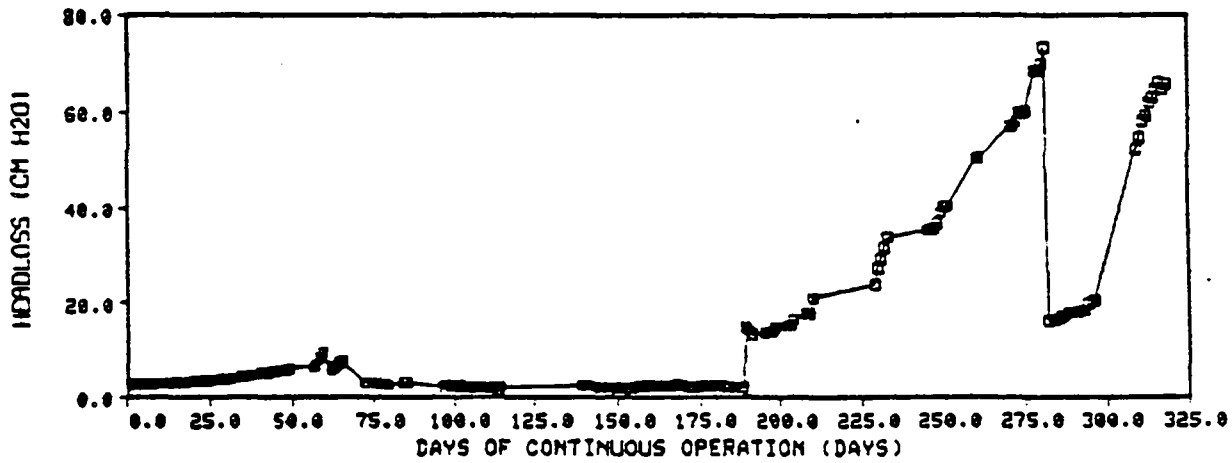
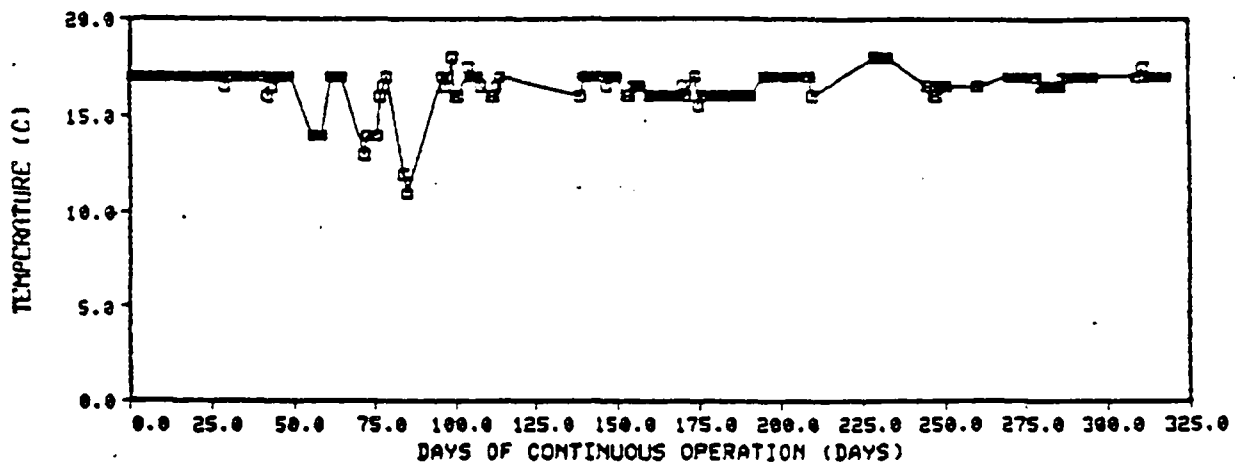

Figure I-6. Graphical operating history of temperature, headloss and hydraulic loading rate for Filter 3 Phase II and Phase III operation.

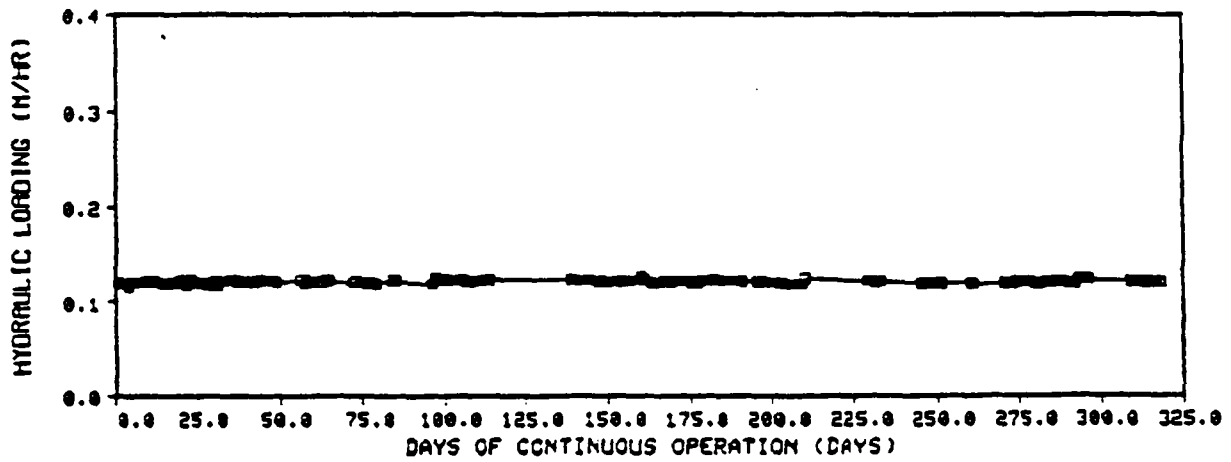
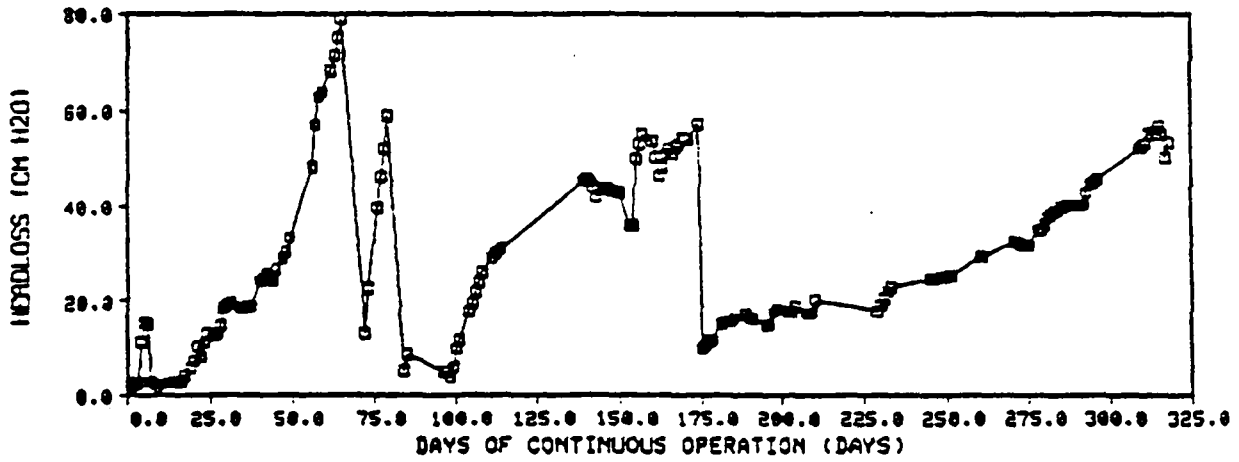
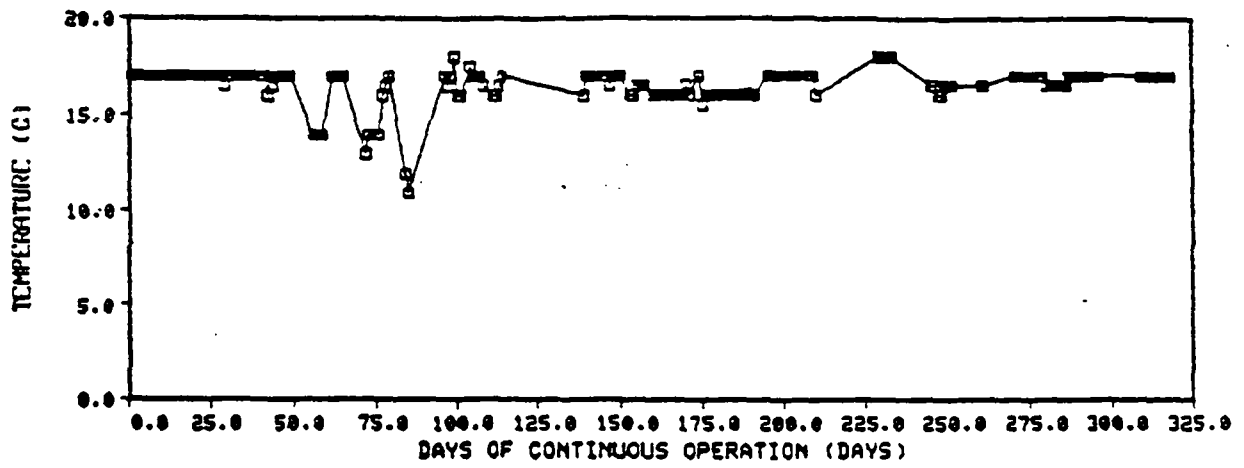

Figure I-7. Graphical operating history of temperature, headloss and hydraulic loading rate for Filter 4 Phase II and Phase III operation.

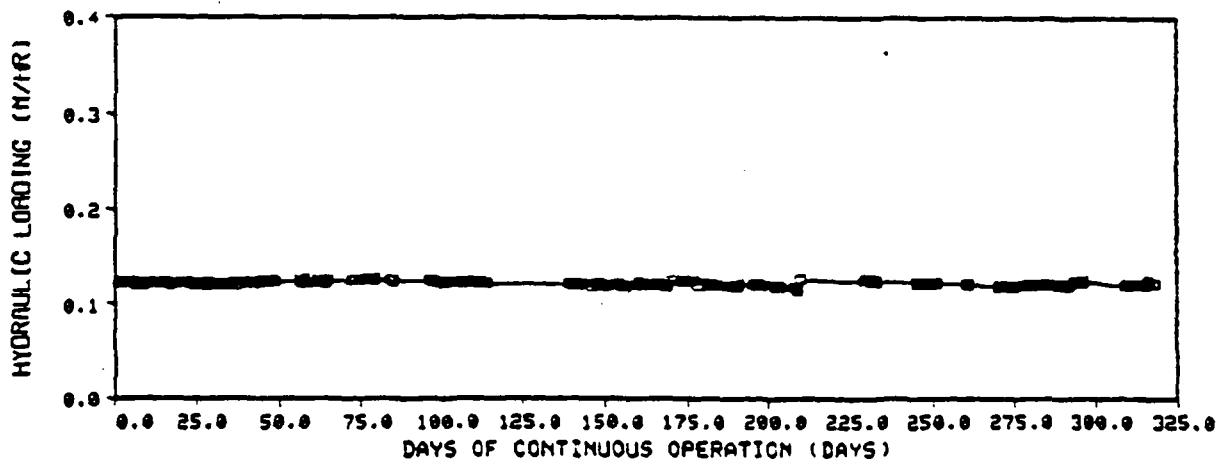
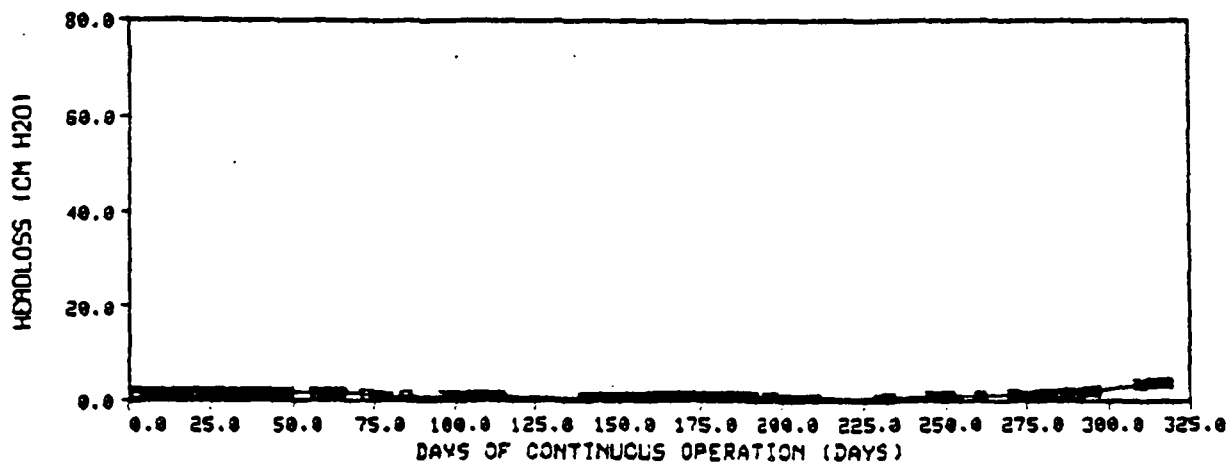
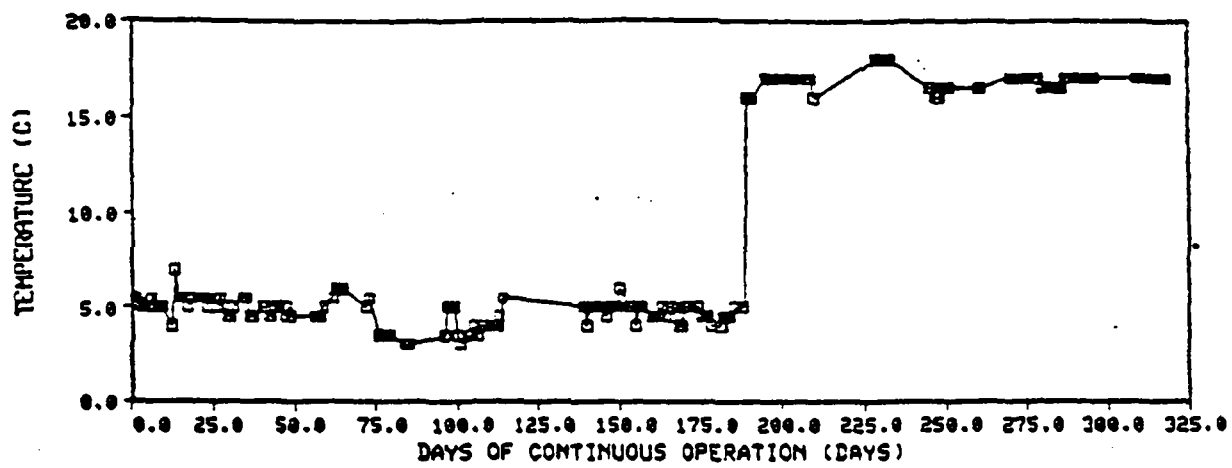

Figure I-8. Graphical operating history of temperature, headloss and hydraulic loading rate for Filter 5 Phase II and Phase III operation.

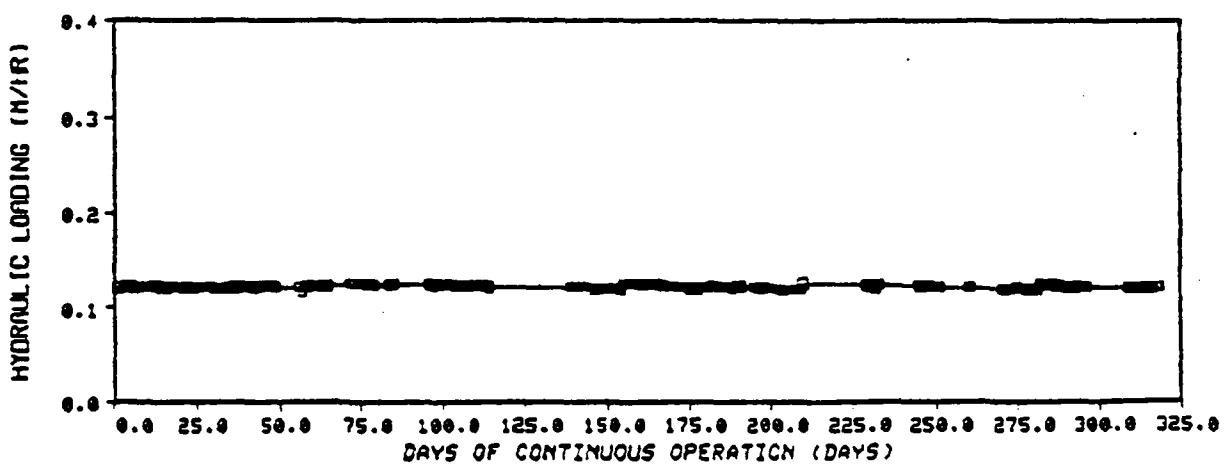
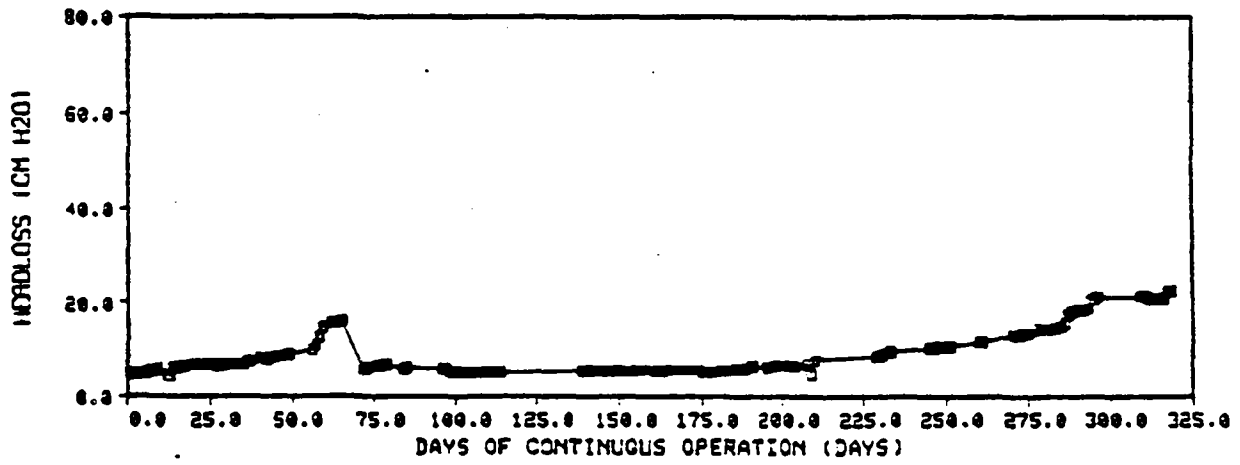
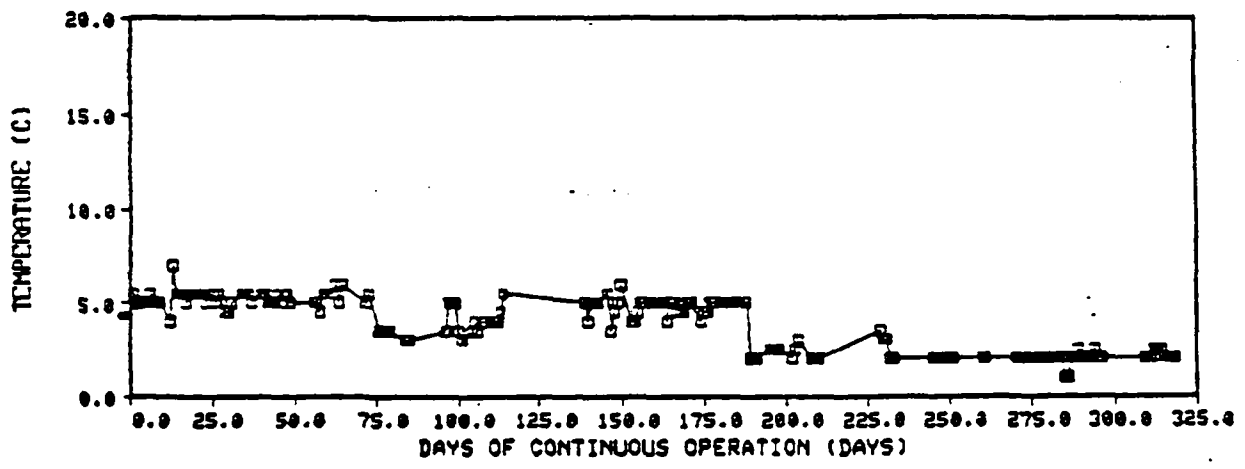

Figure I-9. Graphical operating history of temperature, headloss and hydraulic loading rate for Filter 6 Phase II and Phase III operation.

## APPENDIX J

### Quality Control Data Sheets

The following contains samples of the data sheets used for quality control. Included are pump calibration curves for the FMI and the March piston pumps, standardization forms for pressure gauges, temperature gauges, mercury thermometers, incubators and turbidity meters.

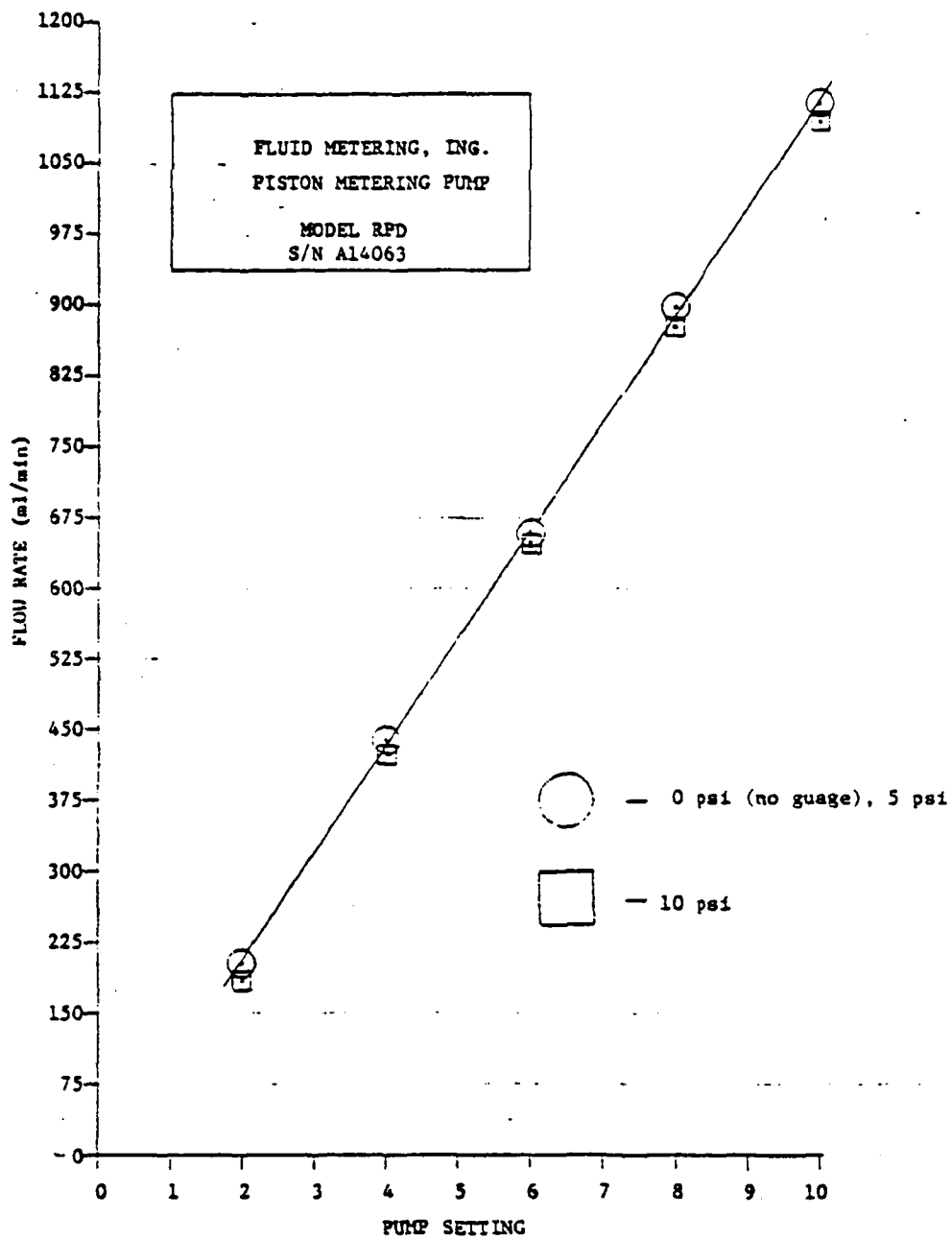

Figure J-1. Calibration curve for Fluid Metering Inc. Pump, Model RPD.

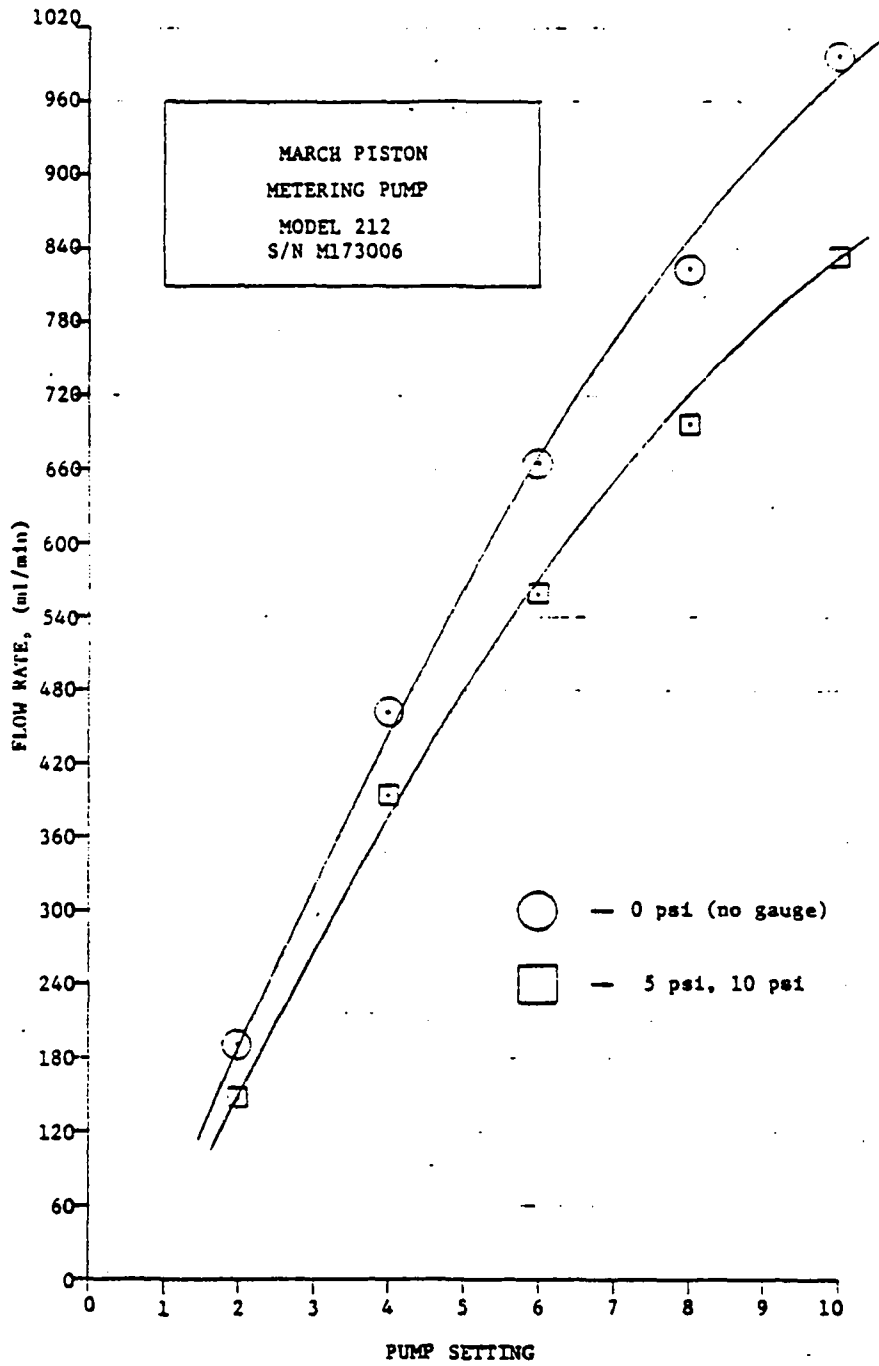

Figure J-2. Calibration curve for March Piston Pump, Model 212.



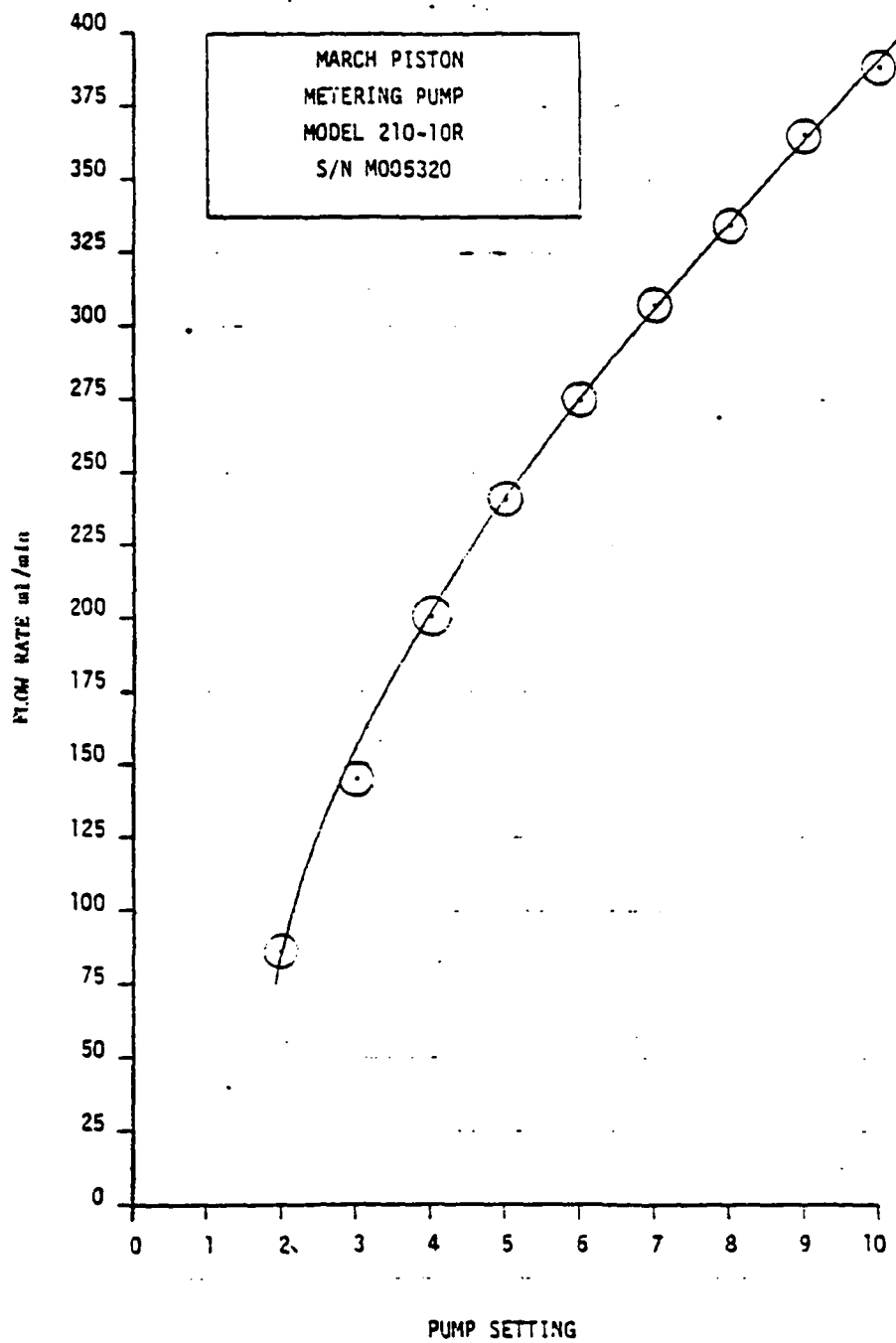

Figure J-3. Calibration curve for March Piston Pump, Model 210-10R.

Table J-1. Pressure gauge standarization data sheet.

PRESSURE GAGE  
STANDARDIZATION SHEET

Manufacturer WEISS  
 Model No. C-7380-22  
 Serial No. 1

Date	Gage Pressure (PSIG)	Manometer Readings	
		cmHg	Pressure equiv. PSIG
6-23	1	4.3	0.8
6-23	5	24.7	4.8
6-23	10	51.7	10.0

Take at least 3 different pressure readings during each standardization.





Table J-4. National Bureau of Standards calibration certificate.

WALTER H. KESSLER COMPANY, INC.

THERMOMETERS



HYDROMETERS

ONE-SIXTY HICKS STREET • WESTBURY, LONG ISLAND, NEW YORK • 516 EDGEWOOD 4-4064

# MANUFACTURERS CERTIFICATE OF CALIBRATION

This is to certify that the instrument listed below has been tested in our temperature calibration laboratory in accordance with the latest procedures in the finest constant temperature equipment available, against National Bureau of Standards certified master standards.

Certified for: Fisher Scientific Co  
Description: Thermometer -1/51C in 0.1° Div totalImm  
Instrument Serial No. 784 715 Date Certified: April 20, 1978

Reading of This Instrument	Reading of N.B.S. Standard (True Temperature)
+0.01C	0.00C
9.98C	10.00C
20.01C	20.00C
30.00C	30.00C
40.00C	40.00C
50.04C	50.00C

The tabulated readings apply provided the ice-point reading taken after exposure for not less than 3 days to a temperature of about 25° C (77° F) is +0.01C. If the ice-point reading is found to be higher (or lower) than stated, all other readings will be higher (or lower) by the same amount.

Serial & Test numbers of National Bureau of Standards certified instruments referenced in certification of the thermometer listed above:

NBS Standard 09762

NBS Test No 187318

WALTER H. KESSLER COMPANY, INC.

Table J-5. Equipment operation record data sheet.

EQUIPMENT OPERATION RECORD <sup>1</sup>

Instrument Ingersoll Model No. 6 Serial No. 11067

Date			Time		Temperature (°C)	Desired Temperature (°C)	Pressure (PSIG)	Desired Pressure (PSIG)
DAY	MO	YR	HR	MIN				
28	07	82	11	00	43.5	43.5	.	.
01	08	82	09	15	43.5	43.5	.	.
02	08	82	13	20	44.0	43.5	.	.
03	08	82	15	30	43.5	43.5	.	.
03	08	82	09	45	43.5	43.5	.	.
08	08	82	14	40	43.5	43.5	.	.
09	08	82	16	00	43.5	43.5	.	.
13	08	82	14	15	43.5	43.5	.	.
14	08	82	15	45	43.5	43.5	.	.
14	08	82	17	30	43.5	43.5	.	.
15	08	82	11	25	43.5	43.5	.	.
16	08	82	14	55	43.5	43.5	.	.
17	08	82	15	50	43.5	43.5	.	.
18	08	82	11	55	43.5	43.5	.	.
19	08	82	10	55	43.5	43.5	.	.
20	08	82	09	20	43.5	43.5	.	.
21	08	82	09	45	43.5	43.5	.	.
22	08	82	02	20	43.5	43.5	.	.
22	08	82	02	00	43.5	43.5	.	.
22	08	82	02	00	43.5	43.5	.	.
22	08	82	02	00	43.5	43.5	.	.
01	09	82	15	45	43.5	43.5	.	.
02	09	82	04	45	43.5	43.5	.	.
02	09	82	04	45	43.5	43.5	.	.
04	09	82	11	45	43.5	43.5	.	.
09	09	82	11	45	43.5	43.5	.	.

Table J-6. Turbidity meter standardization data sheet.

TURBIDITY METER STANDARDIZATION \*

Instrument Hach Model No. \_\_\_\_\_ Serial No. \_\_\_\_\_

Date			Time		Reference Standard Value (NTU)	Meter Reading Prior to Adjustment (NTU)	Meter Reading After Adjustment (NTU)
DY	MO	YR	HR	MIN			
29	09	82	03	40	18.00	18.4	18.4
30	09	82	08	50	18.00	18.1	18.3
30	09	82	09	09	18.30	18.3	18.30
01	10	82	10	40	18.30	18.7	18.20
05	10	82	09	00	18.30	18.3	18.3
06	10	82	09	00	18.30	18.2	18.2
07	10	82	09	14	18.30	18.4	18.4
11	10	82	12	20	18.30	18.2	18.2
13	10	82	10	30	18.30	18.3	18.3
14	10	82	09	40	18.30	18.2	18.2
15	10	82	09	52	18.30	18.2	18.2
20	10	82	09	10	18.30	18.3	18.3
22	10	82	09	10	18.30	18.2	18.2
23	10	82	06	20	18.30	18.2	18.2
24	10	82	09	00	18.30	18.3	18.3
25	10	82	09	10	18.30	18.1	18.1
26	10	82	12	50	18.30	18.1	18.1
27	10	82	12	10	18.30	18.3	18.3
28	10	82	14	00	18.30	18.2	18.2
29	10	82	09	30	18.30	18.2	18.2
30	10	82	09	30	18.30	18.2	18.2
31	10	82	09	30	18.30	18.2	18.2
01	11	82	09	50	18.30	18.2	18.2
03	11	82	09	00	18.30	18.1	18.1
04	11	82	09	10	18.30	18.0	18.0
05	11	82	09	00	18.30	18.1	18.1
07	11	82	09	00	18.30	18.1	18.1
12	11	82	09	45	18.30	18.2	18.2
15	11	82	09	30	18.30	18.2	18.2
18	11	82	09	50	18.30	18.2	18.2
24	11	82	09	50	18.30	18.5	18.5

\* Each meter will be standardized a minimum of once per day during experimental runs.

## APPENDIX K

### GIARDIA CYST PROCUREMENT, ANALYSIS AND DETECTION LIMITS

This appendix contains information on procurement of Giardia cysts, including processing of the fecal samples obtained, sampling efficiency by membrane filtration, techniques for processing samples washed from membrane filters for microscopic counting, detection limits, and an overall discussion of sample processing and cyst counting. The material was based upon the work of Dr. Charles Hibler and was written mostly by Dr. Hibler, with portions written by Dr. W. D. Bellamy (e.g. the portion on detection limits, with editing by the authors.

#### PROCUREMENT OF GIARDIA CYSTS

##### Securing Giardia Cysts

Giardia cysts were obtained from fecal samples of infected dogs. Positive Giardia samples commonly appear as soft to watery stools but normal, firm stools should not be excluded as possibilities. Puppies about six weeks old are the best source but older dogs, bitches, and kennel dogs break frequently.

Fecal samples were collected in baggies and securely closed with twist-tie type closures. Samples were labeled with the pen number, dog number, etc. for future reference and notifying appropriate personnel of the results. The samples were placed in a cooler with ice and transported to the laboratory.

The sources of fecal samples were:

- (1) CHRL - Collaborative Radiological Health Laboratory

Foothills Campus - Beagle Colony  
Call Esther 491-8522 ext 29 for clothes in women locker  
Jim Winic 49208522 for information on puppy litters  
(age, births, breeding, etc.)

- (2) Humane Society for Larimer County

6317 Kyle Ave., Fort Collins 226-3647  
Collect at 7:30 am (before cage cleaning)  
1:00 pm (after feeding)  
Call before collecting to alert staff



(3) Vet. Teaching Hospital

Parasitology Lab 491-7101 ext 233  
Glenda Taton (Parasite Lab Tech) will collect  
heavy infected samples

(4) Oncology - Vet. Teaching Hospital

Oncology 491-7101  
Call Dee or Sharon or Dr. Gillette  
They use beagles from CHRL which break with  
Giardia when moved to the Vet. Hospital

Preparing Cysts for Experimentation

In the laboratory, zinc flotations were performed on each fecal sample to check for the presence of Giardia cysts. This procedure is described below. If cysts were presented, the sample(s) were weighed and added to an equal amount of cool distilled water. The sample was then mixed thoroughly to break apart any aggregates.

If the sample appears extremely dirty it may be filtered through cheese cloth or gauze or the solution may be mixed thoroughly, quickly allowed to settle, poured into another container and the sediment discarded. Each of these procedures will, however, result in the loss of some cysts. Cyst samples and suspensions were refrigerated at all times.

Cyst Identification--

The zinc flotation procedure was used to ascertain the presence of cysts in fecal samples. The procedure is described following. A fecal sample about the size of a pea is placed in a centrifuge tube, 5 to 6 drops of Lugol's Iodine is added to the sample and is mixed well. Fill the tube half way with zinc sulfate solution (spgr 1.18 or 1.20) and mix well. Fill the tube with more solution until the meniscus buldges and affix a coverslip. Place the tube in the centrifuge and tap the coverslip with a pencil end to form a secure bond. \*If the coverslip is not firmly in place it will come off during centrifugation and the procedure will have to be repeated. \*The coverslip must always be handled by its edge as body oils will prevent attachment of the cysts to its surface. Centrifuge the samples at 1500 rpm for 5 minutes. Remove the coverslip and place on a glass slide. Examine the coverslip for Giardia at 100x magnification.

Labelling and Storing Cyst Suspensions

Jars containing suspensions of concentrated cysts were labelled with the date and the number of cysts per ml. The sample should be counted at least every 3rd day and before used in experiments to ensure accurate counts and cyst condition.

## Cyst Counting Techniques Obtained from Membrane Filter Sampling

There are two techniques used to process a sample obtained from membrane filtering to concentrate the cysts for counting. These are: 1) Stoll dilution, and 2) micropipette. For a sample with a large number of cysts, i.e. a fecal suspension, the Stoll technique is usually used. For a sample with a low cyst population, the micropipette technique usually is used. The zinc flotation technique was used for the first six slow sand filter test runs (see report by Bellamy, et al., 1984) and for identifying cysts in fecal samples.

### Stoll Dilution Technique--

The procedure for the Stoll dilution technique is described as follows. Add 3 ml Lugol's Iodine to a Stoll flask and fill the flask to the 56 ml mark with cool distilled water. Mix the fecal suspension well and remove 4 ml liquid. Add the 4 ml to the flask and shake thoroughly. A 0.075 ml aliquot is removed via micropipette and is placed in a vaseline well. A coverslip is affixed and the number of cysts counted at 400x. The total number seen on one slip is multiplied by 200 to give the total number per ml sample. A minimum of 2 coverslips should be read and averaged.

### Micropipette Technique for Samples from Experimentation--

The procedure for the micropipette technique is described as follows. Samples in mason jars under ice will arrive at the laboratory and must sit overnight to allow settling of the cysts and debris. The following day the samples are pipetted down to approximately 200 ml liquid without disturbing the sediment. After the excess water is removed, mix the sample well and pour in a 50 ml conical centrifuge tube. Centrifuge for 5 minutes at 1500 rpm. Pipette off the supernant to about 5 mls and repeat the procedure until all the sample has been concentrated to 1 ml and the sample jar rinsed well with distilled water. The final volume of the concentrate will depend on the amount of debris present in the sample.

To a 1 ml concentrate add 5 to 6 mls Lugol's Iodine and to a 5 ml sample add 10 to 15 mls Iodine. Mix the sample thoroughly and remove a 0.050 ml aliquot via micropipette. Place in a vaseline well, affix coverslip, and scan entire slip at 400x. Note the characteristics of the debris present (protozoa, amorphous, fungal bodies, etc.) and count the number of cysts if any. If cysts are seen a minimum of two aliquots are counted and averaged.

To calculate the number of cysts present in the entire sample the number is multiplied by its corresponding dilution factor, i.e.

a 1 ml concentrate is multiplied by 20

a 5 ml concentrate is multiplied by 100

and a 10 ml concentrate is multiplied by 200

All results are recorded and reported on the standard forms, e.g. Figure K-1. Information which must be included is: date, information included on the sample label, initials of the analyst, counts of duplicate sample readings, final cyst number reported and the observations of the debris appearance.

### Reagents and Supplies

#### Lugol Iodine

1000 ml warm distilled water  
100 gm Potassium Iodine  
50 gm Iodine

Mix till Iodine crystals are in solution. Store in dark bottle - light will deactivate the solution.

#### ZnSO<sub>4</sub> Solution

2-3 gallons distilled water  
3 kg or 1-6.6 lb jar of ZnSO<sub>4</sub> crystals  
Mix till crystals are in solution, place hydrometer into solution to read specific gravity. Keep adding ZnSO<sub>4</sub> till a specific gravity of 1.18 or 1.20 is reached. Store in one gallon glass jars.

#### Coverslips

VWR Micro cover glasses 1 ounce  
Cat No. 48366-227  
22 x 22 mm No. 1 1/2

#### Slides

Scientific Products Micro Slides  
Plain Pre-cleaned  
1.2 mm thick Size 3 x 1 inch  
Cat No. M6130

#### Micro-pipette Tips

Micro-selectapette pipette tips  
Siliconized - For - micro - pipetting  
50-75-100 ul 250 pipettes  
Clay Adams Re-order No. 4711  
Cat No. 53517-423 VWR

GIARDIA QUANTITATION

Filtration  
System

Run Information Analysis Am't. Conc. Analysis Counts of Cyst # Observations  
(sample label) Date in Sample by Replicates Reported and Comments

Figure K-1. Giardia analysis record form.

## MEMBRANE RECOVERY EFFICIENCY

Giardia cysts sampling of filter influent and of filter effluent streams were obtained by the use of 5 micrometer pore size Nucleopore R polycarbonate membrane filters. The filters used with the laboratory-scale pilot plant were 142 mm diameter, while 293 mm diameter filters were used with the field-scale pilot plant. Questions about the recovery efficiency of this technique was addressed in brief experiments and is described here.

### Recovery Efficiency of 5 $\mu$ m Pore Size, 142 mm Polycarbonate Membrane Filters

Several tests were conducted by Dr. Hibler to determine the Giardia cyst recovery efficiency of the membrane filters. Table K-1 summarizes the test results.

The tests were conducted to determine if there was a difference in recovery resulting from different cyst source or resulting from different sampling techniques. Tests 1 and 2 in Table K-1 compared different cyst sources and Tests 2 and 3 compared differences in sampling techniques, i.e., pumping the sample through the membrane filter or sucking the sample through.

These results demonstrate that the variation in recovery of Giardia cysts is a function of the cysts and not the sampling techniques. Test 1 results range from 36 to 54 percent and average 44 percent. Test 2 results (using a different source of cysts) produced recovery results ranging from 74 to 89 percent and averaged 79 percent. This demonstrated the marked effect the cyst source has on recovery. Comparing Test 2 at 79 percent recovery to Test 3 at 81 percent recovery demonstrates the minor variation caused by different sampling techniques.

Tests which complement these results are those which are performed routinely on the filter feed tank during Giardia cyst test runs. Table K-2 summarizes the recovery information developed during the slow sand filter tests (see Bellamy, et al. 1984). Each of these tests represents a different cyst source. Again large variations in recovery, i.e., 18 to 80 percent result when different cysts sources were tested, thus confirming the dependence of recovery on the "state" of the cyst.

The "state" of the cyst and its resultant behavior during the sampling procedure is probably dependent on a number of factors. But, based on our observations and Dr. Hibler's experience, the two most apparent factors are: 1) the source of the cyst, and 2) the age of the cyst.

Based on these results it became apparent that the membrane recovery factor should be determined for each test run and that an average recovery for all test runs should not be used. When a membrane recovery factor for a particular run cannot be calculated, e.g., no influent sample was taken, an average from similar tests has been used.

Table K-1. Cyst concentration by membrane filter sampling compared cyst concentration in source tank as determined by grab sample. Analysis by micropipette technique for both sampling methods. Tests conducted in laboratory of Dr. Charles Hibler, July 1982.

Test Condition and Technique	Run Number	Cyst Concentration Based Upon Grab Sample of Tank (cysts/liter)	Cyst Concentration Resulting from Given Test Condition in the First Column (cysts/liter)	Recovery (%)
1. Cysts concentrated with a pump and membrane filter (cyst batch 1)	1	3,333	1,200	36
	2	3,333	1,800	54
	3	3,333	1,500	45
	4	3,333	1,300	39
	5	3,333	1,550	46
	Average	3,333	1,470	4
2. Cysts concentrated with a pump and membrane filter (cyst batch 2)	1	35,000	25,000	71
	2	35,000	30,000	86
	3	35,000	27,000	77
	4	35,000	26,000	74
	5	35,000	31,000	89
	Average	35,000	27,800	79
3. Cysts concentrated with a membrane filter and vacuum, i.e., no pump (cyst batch 2)	1	35,000	26,000	74
	2	35,000	31,000	89
	3	35,000	28,000	80
	Average	35,000	28,300	81

Table K-2. Comparison of cyst recovered by sampling milk cooler feed tank water using membrane filters with cyst concentrations in tank as computed after adding cyst concentrate suspension. Analyses performed during slow sand filter experiments.

Slow Sand Filter Run Number	Cyst Concentration <sup>1</sup> in Filter Feed Tank	Cyst Concentration Determined by Subsampling the Filter Feed Tank with a Membrane Filter <sup>2</sup>	Membrane Filter Percent Recovery
48	420	196.8	46.8
60	500	399.3	79.9
66	50	35.8	71.7
69	50	31.3	62.6
75	50	15.9	31.8
81	50	32.2	64.3
87	1,000	183.8	18.4
90	1,000	221.0	22.1

<sup>1</sup> Each of these results are the average of 3 to 6 analyses performed on a cyst concentrate of liquefied dog feces which is added to the filter feed tank on a batch basis. Cyst concentration equals a number of cysts in concentrate suspension divided by volume of water in tank.

<sup>2</sup> Each of these results are the average of 4 to 11 analyses. The samples are concentrated with a membrane filter.

The mathematical determination of the membrane recovery factor is:

$$100 \times (\text{detected cyst conc.}) / (\text{known ("added") cyst conc.})$$

The known ("added") cyst concentration is determined by analyzing a cyst concentration, i.e., liquified dog feces, numerous times, then adding the concentrate to the batch filter feed tank. The concentration in the tank is then calculated by the appropriate dilution factor. The "detected" cyst concentration is then determined by analyzing a sample from the filter feed tank. This sample is concentrated with a membrane filter thus allowing for the membrane recovery calculation. The membrane filter recovery efficiencies given in Table K-2 were determined this way.

#### Passage of Cyst Through Membrane Filter

A 5-liter glass container was filled with 4 liters of water. The water was cooled to 5°C and dog feces containing Giardia cysts were added to the container. The feces added contained a sufficient number of cysts to bring the cyst concentration up to 2500 c/l. One liter of the mixture was then filtered through a 5 µm pore size polycarbonate membrane filter. The filtrate was collected in two 500 ml flasks.

There were no Giardia cysts found in either of the filtrate flasks. The entire sample volume was concentrated and analyzed by zinc flotation.

#### Retention of Cysts on Surface of Membrane Filter After Washing

A portion of the membrane filter used in the above experiment, approximately the area of one cover slip, was examined microscopically after it had been washed; no cysts were seen on the membrane filter. A similar but more in-depth examination was performed by Luchtel et al. (1980). This analysis also showed that very few cysts were retained by the membrane filter after washing.

#### DETECTION LIMIT DETERMINATIONS

There are two detection limit calculations used for this experimentation: 1) for each individual micropipette analyses, and 2) for an average detection limit when numerous samples are being considered. Each of these methods are discussed below.

#### Micropipette Detection Limit

The micropipette method of analysis begins by concentrating a sample to one milliliter. In other words all the cysts present in the sample are concentrated to the 1 ml volume. A 0.05 ml (1/20 ml) aliquot is then taken and microscopically examined. This means that if there is only one cyst present in the 1 ml sample concentrate, there is 1/20 chance that it will be withdrawn in the 0.05 ml aliquot. This accounts for the first detection limit factor of:  $(20) / (\text{Number of aliquots examined})$ . In other words, 20 cysts must be present in the 1 ml, and uniformly distributed, to be sure that



one cyst will be withdrawn by one aliquot. If the sample filtered is 100 liters, the detection limit is 20/100, or 0.20 cysts/liter. The total detection limit for a sample on a per liter basis is then calculated by:

$$\frac{20}{\text{Number of aliquots}} \div \left[ \frac{\text{Fractional membrane filter recovery efficiency}}{\text{(liters of sample concentrated)}} \right]$$

This equation accounts for the analysis dilution, the membrane filter recovery, and the size of sample. For example:

Sample size = 100 liters  
Membrane recovery efficiency = 45%  
One aliquot analyzed  
Detection limit =  $\frac{20}{1} \div [(0.45)(100)] = 0.44$  cyst/liter

#### Zinc Sulfate Detection Limit

The zinc float method of analysis is characterized by microscopically examining the entire sample for Giardia cysts. There is no dilution factor associated with this analysis technique. It did become apparent when comparing this technique to the micropipette technique that it resulted in cyst counts of approximately 20 percent less than the micropipette method. Consequently, the detection limit for zinc float analyses on a per liter basis is calculated by:

$$\frac{1}{[(0.80)(\text{Fractional Membrane Recovery})]} \\ (\text{liters of sample conc.})$$

This calculation accounts for the 80 percent recovery by zinc flotation, the membrane filter recovery and the size of sample. For example

Sample size = 50 liters  
Membrane recovery = 35%  
Detection limit =  $1 \div [(0.80)(0.35)(50)] = 0.07$  cysts/liter

#### Average Detection Limit

The average detection limit is used when more than one analysis has been performed for a test run. Rather than physically combining all of the samples into one container and performing one analysis, each sample was analyzed separately and then the results were mathematically combined. This leads to slightly different results but both results are valid. The mathematical approach requires an averaging of detection limits since individual detection limits are not suitable for multiple analyses of the same source. For example, a single source of water is analyzed 100 times for coliforms and none are found in any of the 100 ml samples. The true test accuracy is not demonstrated by reporting the individual test detection limits, i.e. that the source has less than one coliform per 100 ml, when in fact 10 liters of sample were analyzed and no coliforms were found.

The individual detection limit for Giardia analyses is based on the probability of finding one cyst. This can be understood by envisioning the analysis of a thousand 1 ml samples, each having one cyst in them. If one 0.05 ml aliquot is taken from each sample and examined it will be determined, after completing all of the analyses, that there is a one in twenty chance of finding a cyst. The detection limit for each analyses was 20/1 ml or the inverse of the probability of finding one cyst, i.e. 1/20. This factor of 20 is the multiplication factor already discussed.

Since the detection limits are the inverse of the probabilities of finding a cyst it is then appropriate to apply probability calculations to multiply analyses when determining the combined detection limit. The following calculations describe the analysis:

$P$  = Probability of finding one cyst

$N$  = Number of tests

$(1-P)$  = Probability of not finding a cyst

$(1-P)^N$  = Probability of not finding a cyst in  $N$  samples

$1-(1-P)^N$  = Probability of finding a cyst in  $N$  samples

$1/[1-(1-P)^N]$  = Detection limit for  $N$  tests, i.e. inverse of probability of finding a cyst

For example, assume 5 samples were collected with an average membrane recovery factor of 50 percent and that each sample was concentrated from 10 liters.

Individual detection limits =  $(20 \text{ cysts}/1 \text{ aliquot}) / (0.5, \text{ membrane recovery factor}) = 40 \text{ cysts}$   
(only one aliquot was analyzed)

Individual probability of detecting one cysts =  $1/40$

Average detection limit for the 5 tests =  $1/[1-(1-1/40)^5]$   
= 8.41 cysts

Average detection limit per liter =  $8.41/10 = 0.841 \text{ cysts/liter}$

As an alternative the 5 samples in the above example could have been physically combined and the detection limit would have been:

Individual detection limit =  $(20/1)/0.5 = 40 \text{ cysts}$   
(only one aliquot was analyzed)

Individual detection limit per liter =  $40 \text{ cysts}/50 \text{ liter}$   
= 0.8 cysts/liter

This result, as expected, is somewhat lower than the mathematical combination, but for each technique the detection limit is valid.

Detection limits in this report can be for individual analyses or an average for a test run; each is applied to its specific case. An average detection limit is not applied to an individual analysis.

### Conclusions

The counting and sampling experiments conducted in July, August and September of 1982 by Dr. C. Hibler, established that the micropipette technique is the most suitable technique for this work. Different samples from the same suspension, different replicates of the sample, and three persons counting resulted in a maximum difference between any two counts of only about fifteen percent. Although there is no suspension of known cyst concentration to use for a standard, it is believed that the counts by this technique represent the Giardia cyst population in the sample counted.

On sampling efficiency, the use of the 5  $\mu$ m pore size, 142 mm polycarbonate membrane filter represents the best state-of-the-art on sampling at this time. Sampling efficiency of the pump membrane filter system was determined to be primarily dependent on the source and age of cysts being used for a particular experiment. This discovery resulted in the determination of a cyst recovery factor from the membrane filters on a test run by test basis.

### GIARDIA QUANTIFICATION TRIALS

This section describes the preliminary Giardia analytical evaluations performed by Charles P. Hibler, Consetta M. Helmick and Donna G. Howell. The purpose was to develop an accurate and reliable means for quantifying cysts of Giardia.

### Introduction

Accurate quantification for eggs, larvae and cysts of parasitic organisms is extremely difficult because parasites do not produce eggs and larvae continuously, nor do the cyst-producing forms of protozoan parasites encyst (or produce cysts, depending on the species) on a continuous basis. For example, examination of numerous dogs clinically infected with giardiasis has revealed that cyst production (cysts in feces) may vary from extremely low numbers in a fecal sample taken in the morning, to extremely high numbers in a sample taken at noon: results are inconsistent and vary from hour to hour and day to day. Diarrhea causes dilution, resulting in inaccuracy by some techniques, and compaction also results in inaccuracy. Moreover, cyst numbers in one portion of the fecal mass often are much higher (or lower) than those in another portion. Thus, unlike bacteria which frequently continue to multiply as they pass the digestive system, and can be cultured to obtain accurate counts, uniform mixing of eggs, larvae or cysts does not

occur; nor does multiplication occur in the intestinal contents. Quantification of eggs, larvae and cysts necessitates visualization of the organism. Needless to say, experience is a factor, fatigue is a factor, and technique is a factor. If thorough mixing does not occur, or if sampling techniques are poor, inconsistent, or sloppy, the end result is highly variable data.

Parasitologists use two types of techniques for reporting presence or absence of parasites in blood, urine or stool specimens: (1) qualitative, and (2) quantitative. The reason for both qualitative and quantitative techniques is that the presence of parasites in pets and/or humans indicates treatment is necessary; however, since most domestic ruminants and horses, as well as wild species, harbor a few parasites, economics enter into the decision. Irrespective of the technique used, the factors given in the preceding paragraph must be taken into consideration. Moreover, qualifications and experience of the parasitologist in diagnosing parasitism and recognition of a given technique's limitations are additional factors to be considered. Although the author has had 20 years experience diagnosing all of the known types of parasites of man and animals, I will confine my remarks to techniques employed for Giardia.

Qualitative techniques (hopefully) reveal to the parasitologist the presence or absence of parasitic infection. There are a number of qualitative techniques purported to be effective in diagnosing Giardia; however, the actual number of techniques suitable for this purpose are limited. The direct smear, the Willis technique (and a myriad of modifications on the market, most of which are made to sell rather than diagnose), the formalin-ether sedimentation technique (formalin-ethyl acetate), and the  $ZnSO_4$  centrifugal-flotation techniques are those generally employed.

The direct smear, although with obvious limitations, does have a place and can be effectively used by experienced parasitologists, especially when seeking cysts or trophozoites from clinical cases of parasitism if the sample is extremely fresh. Moreover, since some parasitic organisms do not encyst and are too fragile for any flotation technique, (Trichomonas), it is the only means available. The direct smear should not, when negative, be used as the only diagnostic criterion when seeking cysts, eggs, or larvae.

The Willis technique and its many modifications (Fecalyzer, Ovassay, etc.) employ  $MgSO_4$ ,  $NaCl$ ,  $NaN_3$ , or sucrose. These generally are concentrated to a specific gravity of 1.20 to 1.30 (depending upon the chemical) to "float" eggs, larvae and cysts to the surface of a vial, centrifuge tube, etc. They often are allowed to attach to a microscope slide, a coverslip or, alternatively a bacterial loop is used to sample for the presence of organisms in the meniscus. Unfortunately, the chemicals generally used will destroy the fragile cysts of the species of Giardia found in most of the animals of interest (dog, cat, man, beaver, muskrat, etc.). Even if the specific gravity is reduced to 1.17 or 1.18, the great majority of cysts are destroyed. However, if the "overlay" technique is used with sucrose at a specific gravity of 1.13 then cyst destruction is minimal.

The formalin-ethyl acetate sedimentation technique is widely employed by medical technologists, using the excuse that since schistosome eggs are too heavy to float, a sedimentation technique must be employed in the interest of accuracy. The author is not aware of any cases of schistosomiasis occurring among native Americans who have not left the United States; the parasite does not occur in the contiguous 48 states. An advantage of formalin-ethyl acetate is that preservation maintains cysts, eggs, larvae and trophozoites of parasites for extended periods of time, facilitating shipment to a laboratory for diagnosis. Two disadvantages are inherent: (1) The technique does not selectively concentrate anything, for 90 percent of the material placed in the centrifuge tube is present in the centrifugate; and (2) Cysts of Giardia will not maintain for more than two weeks in formalin. Thereafter they disappear (cysts probably rupture, although reason says they should not do so in this preservative). Therefore, it must be considered that if only a few cysts are present they would be difficult to find in the centrifugate, due either to the lack of selective concentration or because they possibly will have ruptured before examination was initiated. Nevertheless, in the hands of an experienced parasitologist this is a valuable tool; time consuming, but valuable.

Experienced parasitologists working with Giardia have stated, on numerous occasions and in a considerable number of publications, that the  $ZnSO_4$  centrifugal-flotation technique is the only reliable concentration technique available for qualitative examination of stool samples.  $ZnSO_4$  is used as a specific gravity of 1.18 when examining fresh (unpreserved) samples and at a specific gravity of 1.20 when examining formalin-fixed specimens. The advantages of  $ZnSO_4$  are that you obtain a selective concentration of cysts at the meniscus (or on a coverslip). A disadvantage is that some cysts are trapped in the fecal mass, or do not attach to the coverslip. This is not a severe disadvantage and does not effect reliability of the method. Another disadvantage is that formalin-fixed cysts (if examined before they rupture) are heavier (more dense?) than fresh cysts and do not float as well. Recently, we have discovered a third disadvantage: when cysts are maintained in water for extended periods of time (several weeks) (is this a mature cyst?), while viable and infective, either rupture in  $ZnSO_4$ , or (as with formalin) become heavier and fail to float well. Possibly the cyst becomes more fragile, even when maintained in water at  $5^{\circ}C$ , over an extended period of time. However, in the authors (limited) experience, they simply do not float, indicating that density has increased. Mixing fresh stool specimens with water (highly diluted specimen), centrifuging and removing the supernatant, followed by  $ZnSO_4$  centrifugal flotation, gives a more accurate estimation of the number of cysts (in this case, per milliliter of suspension) than the examination of the formed stool specimen - providing the specimen is fresh and providing the coverslip is not "greasy." Coverslips marketed by some manufacturers are "greasy" and cysts, eggs, etc., do not attach well. Even though this technique (diluting the specimen with water) approaches quantitative procedures (essentially identical with the modified Stoll technique) it is at best 80 percent accurate in the hands of an experienced parasitologist and much less accurate when done by inexperienced parasitologists who are not aware of the limitations of the technique.

The  $ZnSO_4$  centrifugal-flotation technique, although admittedly qualitative, and not accurate, provides the only means of selective separation of cysts from the dirt, debris, plant material, algae, diatoms, pollen, nematode eggs and larvae, crustaceans and their eggs, arthropod parts, and the myriads of protozoa, etc., found in surface waters that are sources of domestic supply. Currently this is the only means to determine if Giardia cysts are present, and in what relative numbers, in raw water or finished water. When the concentration of cysts is very low (often 1-5 cysts/gallon) any other analytical system currently available would be like looking for the proverbial needle in a haystack! Indeed, in the examination of raw or finished water obtained during epidemics of giardiasis, any procedure other than the selective concentration technique would be an exercise in futility because when you have 8, 16, or 32 water filters to be examined and the Department of Health begging for results, there are not enough experienced people in the United States to provide the answer. Therefore, the state-of-the-art in the real world is that in surface water there are myriads of organisms, together with Giardia and selective concentration is the only reliable means of separation of the cysts from other organisms. In fact, this investigator could care less whether Giardia is or is not present: if organisms the size of (or larger than) Giardia are present in the raw water, and these same organisms (in about the same quantity) are present in the finished water, then the system is at risk. The  $ZnSO_4$  centrifugal-flotation technique is an ideal and very quick method to tell the Department of Health and/or water treatment operator that their filtration and/or treatment system is not removing particulate matter the size of or larger than Giardia. Therefore, the system is at risk if Giardia is introduced into the water supply.

Parasitologists have used, from time to time, a number of quantitative techniques: (1) McMaster Counting Chamber; (2) Whitlock Paracytometer; (3) Stoll Dilution Technique; and (4) Modified Stoll Dilution Technique for the recovery of eggs, larvae, and cysts. Recently investigators working with Giardia have initiated the use of the hemacytometer as well as the direct counting procedure (use of a calibrated micropipette). All of these procedures are simply modifications of similar techniques. All have advantages (depending on the parasite and the host) and all have disadvantages: inaccurate mixing, inaccurate sampling, inexperienced parasitologists, and inexperience with the parasite the individual is counting can result in highly variable data. An excellent example is Giardia. In any given sample some of the cysts are fresh and "plump," the morphology is excellent; some of the cysts are not fresh, and are not "plump," rather they are distorted (dying or dead). Over time (a short period of time!) a dead or dying cyst may not be recognized by the parasitologist. When using a quantitative (dilution) technique, irrespective of what has been diluted (erythrocytes, leukocytes, or Giardia cysts), missing a few can result in highly variable data. Moreover, since Giardia cysts are not readily visualized without some form of stain (e.g., Lugol's Iodine), then overstaining, understaining, or the lack of experience necessary to realize that live, dying, and dead cysts all stain differently will result in variable data.

The technique developed by Stoll requires the use of a special (Erlermeyer) flask marked at 56 milliliters and at 60 milliliters. Fluid (generally water) is added to the 56 milliliter mark and sufficient fecal matter added (determined by Stoll to be 2 grams) to bring the material to the 60 milliliter mark. This is thoroughly shaken and a 0.075 or a 0.10 milliliter sample removed, the eggs, larvae or cysts counted and multiplied by 200 or 100, respectively, to obtain organisms/gram. Since the Stoll technique is essentially a 1:15 dilution, addition of 4 milliliters of suspension provides the parasitologist with the number of organisms/milliliter. A modification of this technique is to mix the sample in the flask with a solution of high specific gravity ( $MgSO_4$ ,  $NaCl$ , etc.), mix, remove a specific amount, add to a centrifuge tube, affix a coverslip and centrifuge. The coverslip is removed and the organisms counted. The problems inherent in the modification of the Stoll technique are the same as the  $ZnSO_4$  centrifugal flotation technique.

The McMaster Counting Chamber, and the Whitlock Paracytometer are specially manufactured slides containing coverslips (calibrated) permanently affixed. The Chamber (or well) for these techniques (similar to the hemacytometer) are constructed to hold a specific volume of fluid (such as the chemicals of high specific gravity previously mentioned). The specimen is mixed with the fluid, pipetted into the Chamber, and the organisms allowed to float. The disadvantages are that they might not float or, as is the case with Giardia, flotation occurs very slowly. Those that float immediately (being closer to the surface) distort and become unrecognizable, only to sink before the remainder have floated. Therefore, the disadvantages of these two techniques make them essentially of no value for counting Giardia and will not be considered further.

While the hemacytometer appears to be a likely candidate for counting Giardia cysts, and will be evaluated, there are several inherent disadvantages that perhaps bear discussion at this point. The hemacytometer was designed for counting blood cells; consequently, the volume of liquid held in the chamber is extremely small. If the number of cysts in the sample are not in sufficient concentration (such as might be anticipated with erythrocytes and/or leukocytes) to provide accurate results, the end result is highly variable data. Moreover, in the authors experience, most parasitologists do not realize that the cysts of Giardia are quite heavy. The simple act of mixing a diluted sample, pipetting this sample, and then transferring a small portion to the hemacytometer chamber generally results in inordinately high counts because the cysts settle just enough to affect the results. Moreover, considering once again the volume of the chamber, extremely low cyst numbers result in inordinately low counts.

Since quantitative procedures have not been developed or evaluated for Giardia, and because evaluation of experimental filtration and/or treatment systems for removal of Giardia necessitate reliable and accurate counting procedures, the purpose of this experiment is to develop accurate procedures and evaluate their reliability when performed by experienced parasitologists. Since all quantitative procedures offering any hope of accuracy and

reliability are dilution procedures, the techniques to be evaluated are: (1) Stoll Technique; (2) Micropipette Technique; and (3) Hemacytometer Technique.

### Materials and Methods

#### Source of *Giardia*—

A large amount of feces was collected from four dogs, each with clinical giardiasis, and the fecal matter mixed with distilled water. The water level was adjusted to 2 liters of suspension. This was then refrigerated at 5°C.

#### Holding Vat—

A 40 liter tank was filled to the 38 liter level with tap water, the chlorine allowed to evaporate for 1 day, and the vat then refrigerated until the water temperature became 5°C.

#### Techniques—

As indicated in the introductory remarks, all of the techniques to be evaluated are essentially dilution techniques, irrespective of their name. Since *Giardia* cysts must be stained to facilitate visualization, Lugol's Iodine was used for this purpose. Needless to say, this necessitated a considerable amount of empirical experimentation to determine the best procedure for staining cysts without interfering with accuracy, reliability, or causing undue distortion, overstaining, or understaining that would likewise affect accuracy and reliability. Ultimately it was determined that a concentrated solution of Lugol's Iodine (parasitologists use many different modifications of this stain) must be added prior to any attempt at counting.

For any given suspension of material another factor needed to be considered: the amount of organic material present which could interfere with accuracy. If too much organic debris is present, and too many cysts per field, microscope fatigue quickly intervenes resulting in inaccuracies affecting the reliability.

#### Micropipette—

A calibrated micropipette manufactured by Clay Adams, with calibrations of 0.05, 0.075 and 0.10 milliliters (Silicone coated glass pipettes #4711) here used throughout for both micropipette (MP) and Stoll dilution technique (SD).

With the MP technique, one milliliter samples were obtained after very thorough mixing, concentrated iodine added, and a 0.05 ml sample withdrawn. This sample was introduced into a vaseline well, a coverslip affixed, and the counts performed. The number of cysts counted, for the 1 ml sample, was multiplied by 20 to obtain cysts/ml.

If the amount of organic debris, and the number of cysts, was too concentrated for accuracy, an additional 4 ml of water was added, making a 1:5 dilution. A 0.05 ml sample removed (as before) and the number of cyst multiplied by 100 to obtain cysts/ml. If the material was still too dense, the sample was diluted to 1:10, a 0.05 ml sample removed and the number of cysts multiplied by 200 to obtain cysts/ml. If further dilution was



necessary, either the SD technique (see below) was employed or the original suspension was diluted.

#### Stoll Dilution Technique—

Iodine was added to a Stoll flask (in about the same proportion as with the MP technique) and the flask filled to the 56 ml mark with distilled water. To this was added enough suspension (4 ml) to bring the volume to 60 ml. This was thoroughly shaken, and a 0.075 ml sample removed, introduced into a vaseline well, a coverslip affixed and the number of cysts counted multiplied by 200 to obtain cysts/ml.

#### Initial Counting—

The 2 liter suspension of fecal material was counted by the MP and SD techniques before addition to the 38 liters of water. The results were (expressed in cysts/ml):

	MP (1:10 dilution)	SD (1:15 dilution)
	24,600	24,400
	25,000	25,200
	<u>25,400</u>	<u>25,400</u>
Average	25,000	25,000

The 2 liters of suspension, when added to the 38 liters of water (1:20 dilution) should provide 50,000,000 cysts in 40,000 ml of water or 1,250 cysts/ml. After addition of the 2 liters of suspension, the vat was maintained at 5°C. Before removing samples for analysis the vat was thoroughly stirred with a large, flat paddle (12 inches wide) for 1.5-2.0 minutes. A 1 ml sample was obtained for use with the MP technique, and a 4 ml sample for the SD technique. Counting of cysts were performed at 450x for evaluation.

#### Results

##### Micropipette—

Counting by the MP technique was performed at 1:1 and 1:5. All counting was performed at 450x. Two (replicates) readings were performed on each sample. The results with 1:1 dilution are tabulated.

##### Comments—

Direct MP counting at 1:1 is an extremely effective, but very time consuming procedure, primarily because of the amount of organic material present. With some water, which contains a considerable amount of algae, diatoms, pollen, protozoa, etc., it is even more time consuming and requires about 1 hour to do a thorough count. An individual can count about 3 samples before the fatigue factor causes data to become variable.

Table K-3. *Giardia* cysts counted by three individuals using the micropipette technique at 1:1 dilution.

	Individual #1	Individual #2	Individual #3
Sample 1	1180	1140	640
Rep	1180	1160	1680
Sample 2	1240	1120	1100
Rep	1240	1160	1080
Sample 3	1300	1160	1000
Rep	1160	1100	940
Sample 4	1340	1160	1000
Rep	1160	<u>1120</u>	<u>1140</u>
Sample 5	1320	Average 1140	Average 1073
Rep	<u>1180</u>		
Average	1230		

Table K-4. *Giardia* cysts counted by three individuals using the micropipette technique at 1:5 dilution.

	Individual #1	Individual #2	Individual #3
Sample #1			
Replicate	1300	1000	1100
Replicate	1100	1200	900
Replicate	1200	1400	1100
Replicate	<u>1400</u>	<u>1100</u>	<u>1000</u>
Average	1250	1175	1025
Sample #2			
Replicate	1200	1000	1400
Replicate	1400	1100	1200
Replicate	1100	1200	1200
Replicate	<u>1100</u>	<u>1400</u>	<u>1300</u>
Average	1200	1200	1250
Sample #3			
Replicate	1500	1200	1400
Replicate	1100	1100	1100
Replicate	1100	1300	1400
Replicate	<u>1200</u>	<u>1400</u>	<u>1400</u>
Average	1225	1250	1325
Sample #4			
Replicate	1200	1200	
Replicate	1200	1100	
Replicate	1400	1300	
Replicate	<u>1100</u>	<u>1100</u>	
Average	1225	1175	

Dilution of the sample to 1:5 resulted in less debris, required less time and the fatigue factor was lower.

Individuals #1 and #2 are more experienced than individuals #3; moreover, #3 had another assignment and often several days would pass between the examination of samples. She commented that becoming accustomed to looking for cysts after a 2-3 days break from the routine was difficult.

The results, with 1:1 or 1:5, are extremely consistent. As might be expected, there appears to be as much variation between individuals as within individuals.

When very little organic debris was present, counting at 100x was possible, however, the individuals discovered that cysts were often missed causing the data to be variable. A recount at 450x in variable resulted in more accuracy.

#### Stoll Dilution—

This is essentially the same techniques as the MP, but the dilution factor is 1:15, a rather dilute solution of material.

#### Comments—

Counting cysts by the SD technique is not as fatiguing, nor is it as time consuming as the MP technique, primarily because of the dilution factor of 1:15; however, accuracy was dependent upon a sufficient number of replicates to obtain a good average. As to be expected, considerable variation occurred within and between individuals. Subsequent trials by the author, reducing the number of cysts (further dilution of the vat sample to an estimated 625 cysts/ml) resulted in even more variation; however, concentration of the vat sample to 2500 cysts/ml indicated that variation in counts was reduced. Tests (replicates) similar to those above were not performed, but it stands to reason that increasing the number of cysts (up to a point!) would increase sampling accuracy, while further dilution would decrease the accuracy.

Considerable time (2 weeks) had elapsed before individual #3 completed her sample #3.

Table K-5. *Giardia* cysts counted by three individuals using the Stoll technique.

Individual #1	Individual #2	Individual #3	
Sample #1			
Replicate	1200	1400	1800
Replicate		1800	1200
Replicate	800	1400	1600
Replicate	2200	1800	
Replicate	<u>1000</u>	<u>1400</u>	<u>1600</u>
Average	1300	1560	1550
Sample #2			
Replicate	1000	1400	1800
Replicate	1600	1200	1200
Replicate	1400	1400	1200
Replicate	1400	1400	1200
Replicate	<u>0800</u>	<u>1400</u>	<u>1000</u>
Average	1240	1360	1280
Sample #3			
Replicate	1400	1600	1000
Replicate	2200	1800	1000
Replicate	800	1400	1000
Replicate	1000	1200	1000
Replicate	<u>1000</u>	<u>1200</u>	<u>1200</u>
Average	1280	1440	1040

\*Cysts were old and had begun to rupture or die.

Hemocytometer—

Initially a 1:5 dilution of the vat sample (250 cysts/ml) was examined with the hemocytometer; however, after repeated samples, no cysts were obtained; therefore, a direct examination of the vat sample (1250 cysts/ml) was attempted, using both stained and unstained cysts. The results were: 0, 0, 0, 0, 1 cysts, 0, 0, 2 cysts, 0, 1 cyst, 0, 0, 0, 0, 1 cysts, 0.

Comments—

The hemocytometer holds a very small volume of liquid. Dilution of a sample to 1000-2000 cysts/ml is far too dilute for any semblance of accuracy. However, if the sample is more concentrated (to what extent I do not know but I suspect in the neighborhood of 10,000-20,000 cysts/ml) no doubt accuracy will increase. Nevertheless, I question the accuracy of the hemocytometer under any circumstances unless the investigator is using extremely clean and/or highly concentrated numbers of cysts. Moreover, it was observed that if cysts were withdrawn from the source, and not pipetted onto the chamber very quickly, the cysts tended to settle to the tip of the pipette. When the small volume is considered, together with the high multiplication factor, this would result in inordinately high numbers of cysts/ml.

### Quantification After Passing the Push-Pull Pump and the Nucleopore Membrane—

Evaluation of data on filtration runs indicates a 60 percent loss of cysts, either in the counting accuracy, the vat, the pump, the membrane filter, or during the processing. Therefore, a vat, containing approximately 38 liters of water was placed into a refrigerator at 5°C. A sufficient quantity of cysts were added to obtain approximately 2 cysts/ml. Results (see below) indicated 2.0 cysts/ml in the vat. A series of pump-filter examinations were made on this material. A total of 2 liters of material was pumped through the filters, the pads washed, and then examined at a 1:5 dilution by the MP technique.

The procedure, during trial runs, is to pump the material through the filter pad then aspirate (with vacuum) the liquid remaining in the filter canister on through the pad. Therefore, to determine where losses were occurring, some runs were aspirated, some were not. For one run, material was not pumped through the filter, but directly into a flask.

### Number of cysts/ml in the Vat—

To determine the number of cysts/ml in the vat 20 ml samples (1 percent of the proposed filtration samples-2 liters) were examined. The 20 ml samples were concentrated to 1 ml and examined by the MP technique.

The results are given below:

	Total Cysts Recovered	
	Sample #1	Sample #2
Replicate	3	3
Replicate	3	0
Replicate	2	1
Replicate	200	200
Average	2.5	1.5

For a 1:1 MP the correction factor is X20; therefore in Sample #1, the average is 50 cysts in 20 ml or 2.5 cysts/ml and in Sample #2 is 30 cysts in 20 ml or 1.5 cysts/ml. This indicates an average of 2.0 cysts/ml. However, the individual reading sample #2 (CPH) had many interruptions and he (CPH) questions the accuracy of his results. The results indicate 4000-5000 cysts should be present in 2 liters. Two to 2.5 cysts/ml, with 20 ml subsamples, is far too dilute to obtain greater accuracy.

### Results Through the Pump and Filter—

A total of 2 liters was passed through the pump at each run. After each filter run, a 20 ml subsample was taken for examination. All counting for the filter-pump trials was done at 1:5 dilution by the MP technique; all counting for the 20 ml subsamples was done at 1:1 by the MP technique. The results are expressed as total cysts present in the sample. The average and percent recovery is also given. Percent recovery was determined, at the time of sampling, by the subsample count using the micropipette technique (Table K-6).

Table K-6. Giardia cysts recovered after passage through the push-pull pump and the filter.

Run #	Procedure	2 liter sample			Average	(% )	20 ml subsample			Ave
		#1 Repli- cate	#2 Repli- cate	#3 Repli- cate			#1 Repli- cate	#2 Repli- cate	#3 Repli- cate	
1	Aspirated	1200	1200	1200	36%	4000	4000	2000	3333	
2	Aspirated	1800	1800	1800	54%	2000	4000	4000	3333	
3	Not Aspirated	1600	1400	1500	45%	4000	2000	4000	3333	
4	Not Aspirated	1200	1400	1300	39%	0	000	6000	3333	
5	Aspirated	1700	1400	1550	46%	2000	4000	4000	3333	
6	Not Filtered	1700	1500	1600	48%	0	6000	4000	3333	

### Comments--

These results indicate that 3,333 cysts should have been recovered from the 2 liter filter samples. Recovery percentages ranged from 36-54 percent (Ave: 45 percent). Losses no doubt occur in all steps of the operation as a result of the pump, filter and the subsequent centrifugation procedures to concentrate the filter washings.

A series of 50 ml subsamples were obtained subsequent to the filter runs and concentrated to 1:1 and read by the MP technique. The results were:

Sample Size	#1	#2	#3	#4	#5	Ave
50 ml	100	80	60	80	60	76

An average of 76 cysts in 50 ml = 152 cysts/100 ml or 1.52 cysts/ml, which extrapolates to 3040 cysts in 2 liters. The original subsamples, taken 2 days earlier, indicated there should be 3,333 cysts in 2 liters.

The cysts, when introduced into the vat had been maintained 5 weeks and were excellent, morphologically. However, the results from this sample of cysts indicated that losses due to death and dissolution of cysts was occurring very rapidly. For example, counts on the day the vat was charged indicated 2-2.5 cysts/ml. The next day results were 1.67 cysts/ml. Two days later the results indicated 1.52 cysts/ml. Microscopic examination indicated they were dying and/or dead: no doubt many ruptured before processing was initiated and, as might be anticipated, processing through the pump and filter, followed by centrifugation, destroyed many more. It is reasonable to assume that dying/dead cysts are more fragile than fresh cysts. Yet there is little way to predict when cysts are going to die, for this seems to vary between individual samples. We have observed (over the past 12 years) that some Giardia samples will keep for weeks and be in excellent shape; others are gone and/or unrecognizable in less than a week. Maintenance in water increases their life span: some cysts will look excellent (morphologically) for 2 months at 5°C while others are beginning to deteriorate at 2-3 weeks. Some cysts in all samples are no doubt more fragile than others and processing will result in a certain amount of dissolution.

### EFFECT OF PUMPING ON CYST RECOVERY

#### Objective

To determine if a loss and/or destruction of Giardia cysts occurs in the process of pumping cysts through the push-pull pump or the nucleopore filter, or if the loss occurs as a result of counting error.

#### Procedure

As in the preceding trial, a 10-gallon tank was filled with tap water, the chlorine allowed to evaporate and the water refrigerated to 5°C. The tank was then charged with 30 ml of dog feces containing 31,000 Giardia cysts/ml or 930,000 cysts (estimated).

The trials were initiated on 9/16/82. A total of five runs were made with the push-pull pump and the nucleopore filter, and one run with the push-pull pump, but no nucleopore filter. Three runs were made with the vacuum pump connected to the nucleopore filter and one run with the vacuum pump, but no nucleopore filter. As in the preceding trial, the number of Giardia cysts/ml was determined prior to the trial, and subsamples from the vat were taken during each trial run.

### Results

The results are presented in tabular form. Table K-7 lists the cysts/ml determined prior to the runs, Table K-8 lists the results of the push-pull pump through the nucleopore filter, and Table K-9 lists the results using the vacuum pump to pull material through the nucleopore filter. At the end of all runs, a 2 liter grab sample was counted. The 2 liter sample was counted by the direct micropipette technique, 1:15 dilution. A total of 78,200 cysts were calculated to be present in 2 liters or 39 cysts/ml.

Table K-7. Giardia cysts/ml determined to be present in the tank prior to trial. Direct micropipette counts, 1:1 dilution of 1 cc samples.

	Total (cysts/ml)	Average (cysts/ml)
Sample 1	40	
Replicate	40	40
Sample 2	40	
Replicate	20	30
Sample 3	40	
Replicate	20	30
Sample 4	20	
Replicate	60	40
Average: 35 cysts/ml		

### Discussion

The results of this trial indicate that when fresh Giardia cysts are used together with the push-pull pump or the vacuum pump through the nucleopore filter, there is very little cyst loss and/or destruction if the personnel are conscientious in preparation, washing of the filter disc, and performing sufficient replicate counts. A comparison of the push-pull pump with the 50 ml grab samples indicates that results are consistent: an average of the six samples revealed 26.2 cysts/ml by the push-pull pump and 26.5 cysts/ml by the grab sample. Although some problems developed with the vacuum pump, an average of four samples revealed 23.5 cysts/ml by vacuum pump and 22.7 cysts/ml grab sample.

Unfortunately, examination of the material on this tank trial took an inordinate amount of time to complete, possibly resulting in a loss of cysts. It took approximately 2 to 2.5 hours to read each sample (22 samples) because of the large number of cysts, debris, and microscope fatigue. From the time the trial was initiated, samples taken, and samples analyzed, there was a 1



Table K-8. *Giardia* cysts/ml obtained following the push-pull pump and filtering through the nucleopore filter. All counts performed by direct micropipette, 1:5 dilution.

Run #	H <sub>2</sub> O Passed	Pressure	Counts	Cysts/ml	50ml Grab Sample	
					Counts	Cysts/ml
1	2000 ml	10 lbs	50,700	25	1600	32
Rep.			49,800	25	1640	33
Rep.			49,500	25	1680	34
Rep.			50,300	25		
Avg.			50,050	25	1640	33
2	1500 ml	15 lbs	45,400	30	1100	22
Rep.			44,700	30	1200	24
Rep.			43,600	29	1120	22
Rep.			43,700	29		
Avg.			44,350	30	1140	23
3	1500 ml	15 lbs	40,200	27	1220	24
Rep.			39,500	26	1100	22
Rep.			39,800	27	1200	24
Rep.			40,500	27		
Avg.			40,000	27	1173	24
4	1500 ml	15 lbs	39,200	26	1400	28
Rep.			39,800	27	1560	31
Rep.			40,300	27	1500	30
Rep.			39,600	26		
Avg.			39,725	26	1486	30
5	1500 ml	20 lbs	45,700	30	1240	25
Rep.			45,500	30	1160	23
Rep.			45,700	30	1300	26
Rep.			46,000	31		
Avg.			45,725	31	1233	25
6*	2000 ml	0 lbs	35,800	18	1140	23
Rep.			40,200	20	1180	24
Rep.			28,200	14	1200	24
Rep.			37,200	19		
Avg.			35,350	18	1173	24

\*Used push-pull pump but not the nucleopore filter

Table K-9. *Giardia* cysts/ml obtained using the vacuum pump to pull sample through the nucleopore filter. All counts performed by direct micropipette, 1:5 dilution.

Run #	H <sub>2</sub> O Passed	Counts	Cysts/ml	50 ml Grab Sample	
				Counts	Cysts/ml
1	1200 ml	30,300	25	1040	
Rep.		33,400	28	1020	20
Rep.		30,400	25	1100	22
Rep.		31,600	26		
Averages		31,425	26	1053	21
2	1500 ml	31,100	21	1100	22
Rep.		30,400	25	1180	24
Rep.		30,800	21	1120	22
Rep.		31,500	21		
Averages		31,200	21	1133	23
3	1300 ml	26,500	20	1180	24
Rep.		29,000	22	1200	24
Rep.		27,800	21	1140	23
Rep.		29,500	23		
Averages		28,200	22	1173	24
4*	2000 ml	48,800	24	1100	22
Rep.		52,600	26	1160	23
Rep.		46,200	23	1120	22
Rep.		49,600	25		
Averages		49,300	25	1126	23

Note: Only 4 runs were made because of pump problems.  
 \*No nucleopore filter, only the vacuum pump.

week to 10-day span which could account for cyst loss via death of cysts. Also centrifugation of samples could apply enough pressure to fragile cysts to cause rupturing and cyst loss. The entire trial took 80 working hours to accomplish, from start to finish. The pretrial count indicated 30-40 (Average 35) cysts/ml, and the 2 liter grab sample, analyzed shortly after the trial, indicated 39 cysts/ml; yet all counts after a 2-day lag were within the 23-33 cyst/ml range. This indicated that, over time, cyst loss was occurring. Possibly, this was due to increased fragility because of age of cysts or that a certain percentage of cysts are fragile initially. Nevertheless, cyst loss was consistent irrespective of the procedure.

## APPENDIX L

### HORSETOOTH RESERVOIR WATER AND PARTICLE ANALYSIS

Horsetooth reservoir water originates from snow melt on the west slope of the Rocky Mountains above Granby Colorado. The water is transferred by tunnel across the continental divide, through three power plants, then by canal to Horsetooth reservoir. Figure L-1 is a photograph of Horsetooth reservoir.

The turbidity of this water source consistently passed through even mature filters; consequently, it was thought to be comprised of fine particles. In June, 1982, Dr. E. R. Baumann of Iowa State University visited the research project and returned to Ames with a sample of Horsetooth Reservoir solids, obtained by filtering reservoir water through a 0.2  $\mu\text{m}$  membrane filter. These samples were analyzed by X-ray diffraction and electron microscopy as described in the following letter. The figures referred to in this letter are not included here. However, the conclusions of the solids analysis are presented. The turbidity causing particles were identified as very small Illite, Kaolinite and Montmorillonite clay particles.



Figure L-1. Horsetooth reservoir looking from the north to south.

August 12, 1982

Dr. David W. Hendricks  
Professor of Civil Engineering  
Colorado State University  
Fort Collins, CO 80523

RE: Samples returned to ISU

Dear Dave:

I brought back to Ames for analysis four 0.2 micrometer Millipore filters which were used to filter samples of water from the Horsetooth Reservoir as follows:

<u>Sample No.</u>	<u>Source</u>	<u>Amt. Filtered</u>
1A } 1B }	Reservoir water filtered through 1.0 $\mu$ m AMF Cuno Micro-Wynd II filter cartridge and then the 0.2 $\mu$ m Millipore	185 ml 165 ml
2A } 2B }	Horsetooth Reservoir water filtered through a 0.2 $\mu$ m Millipore	195 ml 200 ml

Note that the water filtered through the 1.0  $\mu$ m Cuno prefilter removed material that reduced the ability to get water through the 0.2 micrometer Millipore.

At Ames, the ERI - Materials Research Lab processed the samples for me with the following results:

- Figure 1 shows the x-ray pattern caused by a new Millipore filter (1.2  $\mu$ m) so that we could subtract the effect of the membrane from the effect of the membrane plus the suspended solid retained on it.
- Figure 2 shows the x-ray pattern caused by sample 2b (the non-prefiltered reservoir water). The two peaks at 8.8 and 12.3 indicate the presence of Illite and Kaolinite, respectively.
- Figures 3 and 4 show the x-ray patterns caused by samples 1b and 1a, respectively (the prefiltered reservoir water). The peaks at 12.3 indicate once more the presence of kaolinite. The peaks for Illite are still present at 8.8, but are reduced, indicating that the illite particles are larger and probably more effectively removed by prefiltration.
- Samples 1B and 2B were prepared for study on the SEM by sputtering them with about 200  $\text{\AA}$  of gold. Then, a photomicrograph of representative sections of the 0.2  $\mu$ m Millipore filter were taken at magnifications of 1000X and 5,000X.

Note: The 1B samples (Exposure No. 1) contain some particles (diatoms) that have a diameter of 8 to 9  $\mu\text{m}$  even though the sample was prefiltered through a 1.2  $\mu\text{m}$  Cuno (?). The 1B samples (Exposure No. 2) at 5000X shows typical clay particles with a length in the range of 3 to 6  $\mu\text{m}$ . A lot of these particles look like clays, but there is some other debris.

The 2B samples (Exposure No. 3) contain solids that are about 2-4  $\mu\text{m}$  in size and look like clay particles. The 2B samples (Exposure No. 4) contain solids that look like clay and have sizes of 2 to 6  $\mu\text{m}$ , with lots of smaller (much) particles. The larger particles would not significantly contribute to filter clogging as compared to the smaller particles (0.5  $\mu\text{m}$ ).

5. We also used the elemental analysis capacity of the SEM to produce the pattern from the 1B and 2B samples. Note that the element pattern for sample 1B (Figure 5) shows the presence of aluminum, silica, gold (from sputtering), potassium, calcium and iron. These are summarized in Figure 6. These are indications of presence of aluminosilicates. The elemental analysis for sample 2B shows similar results except that there is far less calcium present (Figures 7 and 8). We hypothesize that removal of potassium associated with the illite means that the prefiltered sample has less K and therefore the Calcium shows up.

Conclusion:

There is evidence of the presence of kaolinite, illite and montmorillonite. The illite is removed in large part by prefiltration. The kaolinite and montmorillonite seem to be the fine particles your group has referred to. The montmorillonite presence has to be accepted because of peak changes in the 2-4 range in (Figure 2 - Figure 1). All in all, it looks mainly inorganic which would suggest non-ionic polymer use such as Percol LT-20 on Separan NT-10.

Good luck.

Sincerely,



E. Robert Baumann  
Professor, Civil Engineering

RB/jnw

P.S.: I am not keeping copies of the photomicrographs and figures. They are for your use. You might want one of your staff to interpret them also.

## APPENDIX M

### DISINFECTION BY CHLORINATION

This appendix presents the results of two disinfection tests on the effluents from a slow sand filter and a diatomaceous earth filter.

#### M-1 SUMMARY

This appendix presents the results of two chlorination tests performed on the effluent from a slow sand filter and a diatomaceous earth filter, i.e., Section M-2 and M-3 respectively. Both tests indicate that: 1) the chlorine demand is not excessive, e.g. 0.75 mg/l and 1.6 mg/l chlorine demand often 24 hours, even for turbidities >7 NTU; 2) 1 ppm chlorine effectively killed all coliforms; and 3) the membrane and MPN methods were comparable.

The reason these waters are effectively treated with chlorine, even at elevated turbidities, is due to the nature of the turbidity. The turbidity exhibits very little chlorine demand and it is unable to provide a place for bacteria to "hide." The turbidity which passes a slow sand filter or diatomaceous earth filter is going to be comprised mostly of small particles, i.e., <12  $\mu$ m as determined by particle analyses.

The results from both of these tests support the contention that slow sand filtration and diatomaceous earth filtration should be considered for a waiver of the turbidity standard when conditions warrant. A waiver should be granted, however, only after proper testing has confirmed that the source under consideration behaves in a similar manner to Horsetooth water.

#### M-2 CHLORINE DISINFECTION TEST OF SLOW SAND FILTER EFFLUENT

The following is a memo written by Dr. Keith Elmund of the City of Fort Collins to D. W. Hendricks:

The original (slow sand filter effluent) sample was split with half being chlorinated to approximately 2.5 mg/L free available chlorine (FAC). The remaining portion served as an untreated control. Split samples were run simultaneously using the Most Probable Number (MPN) and Membrane Filtration (MF) techniques.

The relationships between elapsed time between sample analyses, chlorine residual, MPN and MF dilutions used are shown below:



Time	FAC (mg/L)	MPN			MF		
		(colonies/100 ml)			(colonies/100 ml)		
0 hrs	2.5	0	0	0	0	0	0
0.5 hrs	2.0	0	0	0	0	0	0
1.0 hrs	2.0	0	0	0	0	0	0
5.0 hrs	1.5	0	0	0	0	0	0
24 hrs	0.9	0	0	0	0	0	0
Volume tested (ml)		10	1.0	0.1	100	10	1

Note: The samples turbidity was 7.1 NTU.

The results of the total coliform analyses (adjusted count) on the unchlorinated (control) sample using the membrane filtration technique are given below:

Time	Total Coliform/100 ml	Atypicals/100 ml
0 hrs	26	76
0.5 hrs	18	118
1.0 hrs	22	105
5.0 hrs	7	88
24 hrs	9	127

The corresponding MPN results for the unchlorinated control were as follows:

Time	Presumptive	Confirmed	MPN Index/100 ml	95% CI
0 hrs	5-1-0	5-1-0	33	11-93
0.5 hrs	5-1-0	4-1-0	17	5-46
1.0 hrs	5-1-1	4-1-1	17	5-46
5.0 hrs	5-0-0	5-0-0	23	7-70
24 hrs	5-0-0	5-0-0	23	7-70

Presumptive: no additional positives observed after 24 hrs. MPNs carried through the confirmed step only.

No growth was observed from any of the chlorinated samples using either the MPN or MF techniques. All negative controls for both the MF plates and MPN tubes were negative (no growth).

### M-3 CHLORINE DISINFECTION TEST OF DIATOMACEOUS EARTH FILTER EFFLUENT

It became apparent during the diatomaceous earth filtration testing that normal water treatment grades of diatomaceous earth, such as Celite 503 and Celite 545, would not meet 1 NTU turbidity standard when treated Horsetooth Reservoir water. This is due to the small particle sizes which comprise the majority of the turbidity, e.g., about 30 percent of the turbidity remains in NTU after filtration through a 0.45  $\mu$ m membrane filter. This residual turbidity was identified tentatively by Dr. E. R. Baumann as kaolinite and

montmorillonite clay particles. Because the turbidity remaining after diatomaceous earth filtration exceeds the 1 NTU standard, it was decided that a preliminary disinfection study would be performed to determine if this type of residual turbidity caused a large chlorine demand or interfered with bacterial inactivation in meeting the bacterial standards for drinking water.

Table M-1 summarizes the test conditions and results. The water tested was Horsetooth Reservoir water which had been filtered through Celite 503 at 1 gpm/ft<sup>2</sup>. The water had been spiked with sewage prior to filtration. The total coliform tests were performed by membrane filtration with a modified delayed incubation, i.e., conventional media was used with an overlay of tryptone glucose extract agar. These were prepared just prior to analysis. This method allows for bacterial stabilization prior to being subjected to excessive inhibitory chemicals from the Endo-type medium. The chlorine concentrations were measured by titration with a Hach digital titrator. The chlorine source was sodium hypochlorite (bleach). A 10 percent sodium thiosulfate solution was employed to inactive all chlorine residual upon collection of the total coliform samples.

As demonstrated by the results in Table M-1, it is evident that there is not an excessive chlorine demand. Further testing is required under more controlled conditions, i.e., closed containers, to find the true chlorine demand. Also, it is apparent that disinfection for total coliforms is very good. One part per million chlorine effectively reduced the coliform count to the lower detectable limit in 20 minutes at 19°C and at 7.2 pH. Also, these results compare favorably with those observed on a routine basis at a municipal water treatment plant using the same water source but reducing the turbidity to below 1 NTU.

Table M-1. Disinfection of effluent water from diatomaceous earth filtration test, Celite 503.

Time (min)	Control (No Chlorine)	Chlorine (1 ppm)	Chlorine (5 ppm)
0	Cl <sub>2</sub> = 0 Colif=2100/100ml	Cl <sub>2</sub> = 1 ppm <sup>2/</sup> Colif=2900/100ml <sup>3/</sup>	Cl <sub>2</sub> = 5 ppm <sup>2/</sup> Colif=2200/100ml <sup>3/</sup>
20	Cl <sub>2</sub> = 0 Colif=2100/100ml	Cl <sub>2</sub> = 0.46 ppm <sup>4/</sup> Colif=<1/100ml <sup>5/</sup>	Cl <sub>2</sub> = 5.15 ppm Colif=<1/100ml
80	Cl <sub>2</sub> = 0 Colif=2400/100ml	Cl <sub>2</sub> = 0.27 Colif=<1/100ml	Cl <sub>2</sub> = 5.10 ppm Colif=<1/100ml
24 (hrs)	Cl <sub>2</sub> = 0 Colif=2300/100ml	Cl <sub>2</sub> = 0.25 Colif=<1/100ml	Cl <sub>2</sub> = 3.6 ppm <sup>6/</sup> Colif=<1/100ml

<sup>1/</sup> The water for these tests is the filtrate from a D.E. filtration test run conducted with Horsetooth Reservoir water which had been spiked with sewage. The D.E. filter operating conditions were: 13°C, 1 gpm/ft<sup>2</sup>, Celite 503, influent turbidity of 9.9 NTU and effluent of 8.7 NTU.

<sup>2/</sup> These chlorine concentrations were based on calculations. A known concentration of sodium hypochlorite was added to each test volume of filtrate. The sodium hypochlorite concentration was checked by adding a known quantity to a known volume of distilled-deionized water and immediately measuring the chlorine content.

<sup>3/</sup> These samples were taken just prior to adding the chlorine.

<sup>4/</sup> These chlorine measurements were made with a Hach digital titrator and meter.

<sup>5/</sup> Numerous atypical colonies were seen on the plate, but confluent growth of atypical colonies does not allow us to conclude absence of coliforms on these plates. They must be reported as "confluent growth" and specify as "presence or absence of sheen." For potable waters, confluent growth requires resampling and retesting. This must be considered in this report.

<sup>6/</sup> These experiments were performed in open top containers, this value is probably due to loss of Cl<sub>2</sub> to the atmosphere.

## APPENDIX N

### PARTICLE COUNTING PROTOCOL

The following is a list describing the protocol used for particle counting with the Model TA II, Coulter Counter. It discussed only those steps used to prepare samples for counting and not the actual operating procedure for the instrument. These can be found in the owner's manual for the Coulter Counter, Model TA II.

Figure N-1 in this appendix is a manufacturer's worksheet for recording aperture information, calibration settings and the particle size ranges corresponding to the sixteen counting channels. The size range of greatest interest to this research was 7-12  $\mu\text{m}$ , i.e., *Giardia* sized particles, roughly approximated by channels 7, 8 and 9, or 6.35-12.7  $\mu\text{m}$ . The actual recording of sample data was not done on this worksheet but on the worksheet and computed coding form presented in Appendix O.

## Appendix N

### PARTICLE-COUNTING PROTOCOL

1. Turn on machine and vacuum pump and allow them to warm up for about 30 minutes prior to using.
2. Collect filter samples in 500 ml glass bottles, wash with 0.2  $\mu$ m filtered, distilled water to make "particle free."
3. Fill a "particle free" sample beaker to 207 ml with sample.
4. Add 15 ml of 0.2  $\mu$ m filtered, 20 percent NaCl solution to give a 1.5 percent by weight electrolyte solution.
5. Place sample in Coulter Counter and stir sample with the glass mixer provided until the solution is homogeneous. Mix slowly to prevent formation of air bubbles.
6. Run sample for 500 seconds. Follow operating instructions in Coulter Counter, Model TAI, Owner's Manual.
7. Print out particle totals from channel 3-16. Corresponding particle size ranges for each channel are given in Table N-1.
8. Between samples spray off aperture tube and electrode with a particle free 1.5 percent by weight NaCl solution to prepare for next sample.
9. Repeat Steps 3 - 8 for each sample.
10. Before and after filter samples, run a blank sample of 0.2  $\mu$ m filtered, distilled water with added electrolyte solution for background counts.
11. Before and after samples have been counted, switch machine to "manometer mode" and check flow rate of liquid through the aperture.
12. Turn off machine and vacuum pump and leave electrode and aperture tube submersed in sample beaker to preserve until next use.

Table N-1. Coulter Counter calibration worksheet.

<b>COULTER COUNTER® Model T &amp; T<sub>A</sub> Worksheet</b>										
SAMPLE										
ELECTROLYTE <i>1.5% NaCl</i>					DISPERSANT <i>None</i>					
EQUIPMENT <i>TA II</i>		SERIAL		Aper. Dia.	Ser. No.	CALIBRATION DATA	Part. Dia.	W	± I.A.	A
ORGANIZATION <i>CSU - CE</i>					<i>140</i>		<i>Micros.</i>	<i>10.22</i>	<i>9</i>	<i>2.0375</i>
OPERATOR		DATE								
$k = d \sqrt{\frac{2W}{A}}$ FOR MODEL T		± I.A. _____ CALIB. A _____ APERTURE DIA. _____		$\frac{A_2}{A_1} = \left(\frac{\sigma_2}{\sigma_1}\right)^2 \cdot 2(W_2 \cdot W_1) \text{ For Model T}$						
				$\frac{A_2}{A_1} = \left(\frac{\sigma_2}{\sigma_1}\right)^2 \cdot 2(W_2 \cdot W_1) \text{ For Model T}_A$						
				SAMPLE DATA						
Geometric Mean $\mu^3$	Volume $\mu^3$	Diameter $\mu$	Channel (W)							
.00575	.004091	.198								
0115	.008181	.250								
0231	.01636	.315								
.0462	.03272	.397								
.0925	.06545	.500								
.1851	.1309	.630								
.3702	.2618	.794								
.7405	.5236	1.00								
1.481	1.047	1.26								
2.962	2.094	1.59	1							
5.924	4.189	2.00	2							
11.85	8.378	2.52	3							
23.70	16.76	3.17	4							
47.39	33.51	4.00	5							
94.78	67.02	5.04	6							
189.6	134.0	6.35	7							
379.1	268.1	8.00	8							
758.3	536.2	10.08	9							
1516.	1072.	12.7	10							
3033.	2145.	16.0	11							
6066.	4289.	20.2	12							
12.13 x 10 <sup>3</sup>	8579.	25.4	13							
24.27 x 10 <sup>3</sup>	17.16 x 10 <sup>3</sup>	32.0	14							
48.54 x 10 <sup>3</sup>	34.31 x 10 <sup>3</sup>	40.3	15							
97.18 x 10 <sup>3</sup>	68.63 x 10 <sup>3</sup>	50.8	16							
194.4 x 10 <sup>3</sup>	137.3 x 10 <sup>3</sup>	64.0								
388.7 x 10 <sup>3</sup>	274.5 x 10 <sup>3</sup>	80.6								
777.4 x 10 <sup>3</sup>	549.0 x 10 <sup>3</sup>	101.6								
1.555 x 10 <sup>6</sup>	1.098 x 10 <sup>6</sup>	128.								
3.109 x 10 <sup>6</sup>	2.196 x 10 <sup>6</sup>	161.								
6.219 x 10 <sup>6</sup>	4.392 x 10 <sup>6</sup>	203.								
12.44 x 10 <sup>6</sup>	8.784 x 10 <sup>6</sup>	256.								
24.88 x 10 <sup>6</sup>	17.57 x 10 <sup>6</sup>	322.								
49.75 x 10 <sup>6</sup>	35.14 x 10 <sup>6</sup>	406.								
99.50 x 10 <sup>6</sup>	70.27 x 10 <sup>6</sup>	512.								
199.0 x 10 <sup>6</sup>	140.6 x 10 <sup>6</sup>	645.								
398.0 x 10 <sup>6</sup>	281.1 x 10 <sup>6</sup>	812.								
796.0 x 10 <sup>6</sup>	562.2 x 10 <sup>6</sup>	1024								

## APPENDIX O

### DATA SHEETS AND COMPUTER CODING FORMS

The data sheets used to record experimental data are presented in the tables that follow. Two kinds of data sheets were used; computer coding forms and worksheets. Worksheets were used for all microbiological testing, Giardia cyst counting, and particle counting. These sheets contain raw data as well as the reported results, i.e., the total coliform worksheet shows the dilutions used for each sample, the count from each dilution and the reported result from each sample. The sample results, as determined from these worksheets, are transferred to the computer coding forms for further data processing. Daily operational data such as temperatures, pressures, flow rates, and turbidities are recorded directly onto a computer coding form at the time of the reading.

Table O-1. Operational data computer coding form, Phase I.

DATA COLLECTION SHEET  
SLOW SAND FILTRATION  
(SSF)

Filter Column No. 3

page      of     

Mode of Operation	Run Number	Date			Time		Feed Tank Volume (liters)	Feed Tank Temperature (°C)	Feed Tank Turbidity (NTU)	Pump Pressure (PSIG)	Filter Temperature (°C)	Top Pressure Filter (PSIG)	Differential Filter Pressure (CM)	W.P. Fluid	Turbidity (NTU)	Flow Meter (% Scale)	Filterate Tank Volume (liters)	Filterate Tank Temperature (°C)	pH	Calculated Flow (ml/min)	Measured by (Initials)
		Day	Month	Year	Hour	Minutes															
SSF	09	08	08	82	21	10	111.0	2.0	2.2	12.0	2.2	5.9	9.4	W	2.6	0	0	7.5	436	SS	
SSF	10	08	08	82	21	10	112.0	2.0	2.2	12.0	2.2	2.9	5.5	W	3.0	0	0	7.5	435	SS	
SSF	11	08	08	82	21	10	112.0	2.0	2.2	12.0	2.2	2.9	5.6	W	3.0	0	0	7.5	435	SS	
SSF	12	08	08	82	21	10	112.0	2.0	2.2	12.0	2.2	2.9	5.9	W	3.0	0	0	7.5	437	SS	
SSF	13	08	08	82	21	10	112.0	2.0	2.2	12.0	2.2	2.9	5.7	W	3.0	0	0	7.5	436	SS	
SSF	14	08	08	82	21	10	112.0	2.0	2.2	12.0	2.2	2.9	5.7	W	3.0	0	0	7.5	435	SS	
SSF	15	08	08	82	21	10	112.0	2.0	2.2	12.0	2.2	2.9	5.7	W	3.0	0	0	7.5	435	SS	
SSF	16	08	08	82	21	10	112.0	2.0	2.2	12.0	2.2	2.9	5.7	W	3.0	0	0	7.5	435	SS	
SSF	17	08	08	82	21	10	112.0	2.0	2.2	12.0	2.2	2.9	5.7	W	3.0	0	0	7.5	435	SS	
SSF	18	08	08	82	21	10	112.0	2.0	2.2	12.0	2.2	2.9	5.7	W	3.0	0	0	7.5	435	SS	
SSF	19	08	08	82	21	10	112.0	2.0	2.2	12.0	2.2	2.9	5.7	W	3.0	0	0	7.5	435	SS	
SSF	20	08	08	82	21	10	112.0	2.0	2.2	12.0	2.2	2.9	5.7	W	3.0	0	0	7.5	435	SS	
SSF	21	08	08	82	21	10	112.0	2.0	2.2	12.0	2.2	2.9	5.7	W	3.0	0	0	7.5	435	SS	
SSF	22	08	08	82	21	10	112.0	2.0	2.2	12.0	2.2	2.9	5.7	W	3.0	0	0	7.5	435	SS	
SSF	23	08	08	82	21	10	112.0	2.0	2.2	12.0	2.2	2.9	5.7	W	3.0	0	0	7.5	435	SS	
SSF	24	08	08	82	21	10	112.0	2.0	2.2	12.0	2.2	2.9	5.7	W	3.0	0	0	7.5	435	SS	
SSF	25	08	08	82	21	10	112.0	2.0	2.2	12.0	2.2	2.9	5.7	W	3.0	0	0	7.5	435	SS	
SSF	26	08	08	82	21	10	112.0	2.0	2.2	12.0	2.2	2.9	5.7	W	3.0	0	0	7.5	435	SS	
SSF	27	08	08	82	21	10	112.0	2.0	2.2	12.0	2.2	2.9	5.7	W	3.0	0	0	7.5	435	SS	
SSF	28	08	08	82	21	10	112.0	2.0	2.2	12.0	2.2	2.9	5.7	W	3.0	0	0	7.5	435	SS	
SSF	29	08	08	82	21	10	112.0	2.0	2.2	12.0	2.2	2.9	5.7	W	3.0	0	0	7.5	435	SS	
SSF	30	08	08	82	21	10	112.0	2.0	2.2	12.0	2.2	2.9	5.7	W	3.0	0	0	7.5	435	SS	

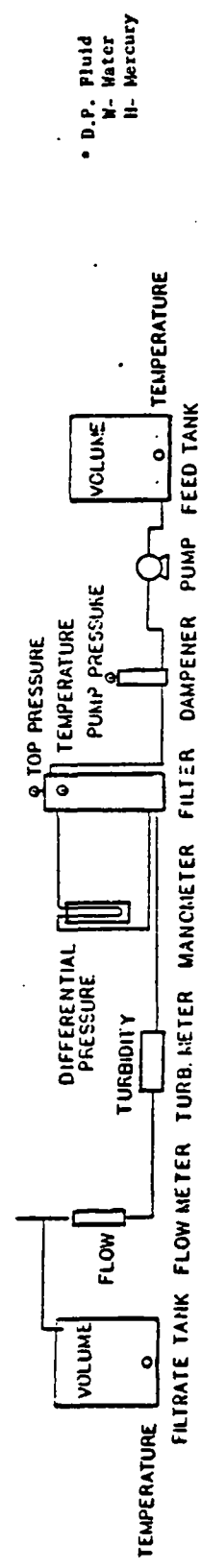

- D.P. Fluid
- W- Water
- H- Mercury

\*\* Calculate the flow by dividing either the difference of the feed tank volume or filtrate tank volume by the elapsed time,  $\frac{(V_n - V_{n-1})}{(T_n - T_{n-1})}$  ml/min

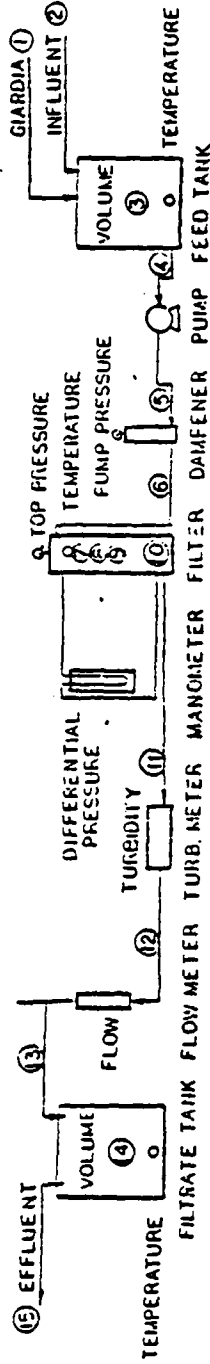

Table O-2. Giardia data computer coding form, Phase I.

SAMPLE COLLECTION AND ANALYSIS SHEET  
GIARDIA  
SLOW SAND FILTRATION  
(SSF)

Filter Column No. 1

Mode of Operation	Run No.	Date of Sample			Time of Sample		Location Number	Sample Number	Type of Sample (CF, MF, G)*	Analysis Results No./L	Collected By Initials	Analysis By Initials
		DAY	MO	YR	HR	MIN						
SSF	087	08	08	82	22	11	01	MF	173	GPS		
SSF	087	08	08	82	11	45	02	MF	173	GPS		
SSF	087	08	08	82	10	25	03	MF	0	GPS		
SSF	087	08	08	82	06	50	04	MF	0	GPS		
SSF	087	08	08	82	11	15	05	MF	256	GPS		
SSF	087	08	08	82	10	00	06	MF	183	GPS		
SSF	087	08	08	82	09	05	07	MF	0	GPS		
SSF	087	08	08	82	08	30	08	MF	0	GPS		
SSF							09					
SSF												



- \* Type of Sample
- CF - Cartridge Filter
- MF - Membrane Filter
- G - Grab Sample

Table O-3. Total coliform data computer coding form, Phase I.

SAMPLE COLLECTION AND ANALYSIS SHEET  
 COLIFORM  
 SLOW SAND FILTRATION

Filter Column No. 1

Mode of Operation	Run No.		Date of Sample			Time of Sample		Location Number	Sample Number	Analysis Results No./100 ml	Collected By Initials	Analysis By Initials
	DY	MO	YR	HR	MIN							
SSF	007	08	81	17	00	00	003	C01	50	MDP		
SSF	007	08	81	17	00	00	003	C02	220	MDP		
SSF	007	08	81	18	05	05	003	C03	0	SPS		
SSF	007	08	81	18	05	05	003	C04	190	SPS		
SSF	007	08	81	18	05	05	003	C05	0	SPS		
SSF	007	08	81	18	05	05	003	C06	0	SPS		
SSF	007	08	81	18	05	05	003	C07	0	MDP		
SSF	007	08	81	18	05	05	003	C08	0	MDP		
SSF	007	08	81	18	05	05	003	C09	0			
SSF	007	08	81	18	05	05	003	C10	0			

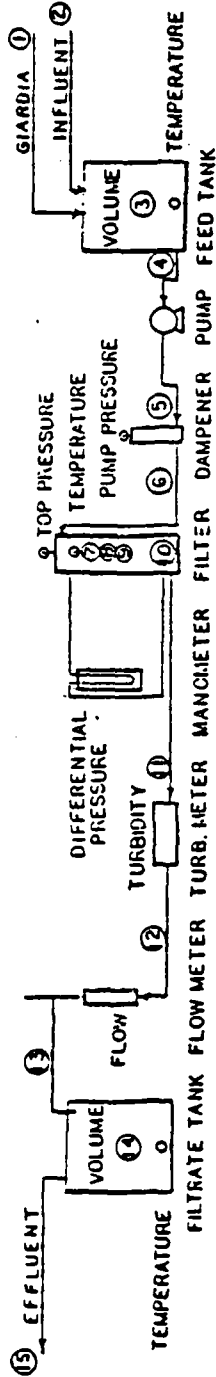

99 - Sample of dilution and rinse water for negative Coliform control

Page 1 of 1

Table O-4. Standard plate count data computer coding form, Phase I.

SAMPLE COLLECTION AND ANALYSIS SHEET  
 TOTAL PLATE COUNT (T)  
 SLOW SAND FILTRATION (SSF)

Filter Column No. 1

Mode of Operation	Run No.	Date of Sample	Time of Sample	Location Number	Sample Number	Analysis Results (no./l)	Collected By Initials	Analysis By Initials
SSF	1118	22/01/82	11/50	011	T/1	2800	SPB	
SSF	1118	24/01/82	11/50	003	T/2	960	SPB	
SSF	1118	24/01/82	11/50	011	T/3	2600	SPB	
SSF	1118	26/01/82	11/00	003	T/4	270	SPB	
SSF	1118	26/01/82	11/00	011	T/5	1630	SPB	
SSF					T/6			
SSF					T/7			
SSF					T/8			
SSF					T/9			
SSF					T/10			

Table O-5. Particle count data computer coding form, Phase I.

SAMPLE COLLECTION AND ANALYSIS SHEET  
 PARTICULATE COUNT (P)  
 SLOW SAND FILTRATION  
 (SSF)

Filter Column No. 1

Mode of Operation	Run No.	Date of Sample			Time of Sample	Location Number	Sample Number	Analysis Results	Collected By	Analysis By
		DAY	MO	YR	HR			No./100 ml	Initials	Initials
SSF	047	26	02	82	19/30	203	101	1769	SPS	
SSF	047	27	02	82	25/30	203	102	1609	SPS	
SSF	047	27	02	82	09/30	011	103	290	SPS	
SSF	047	28	02	82	10/00	003	104	1720	WDB	
SSF	047	28	02	82	09/09	011	105	89	WDB	
SSF	047	01	03	82	14/00	203	106	1738	WDB	
SSF	047	01	03	82	12/43	211	107	81	WDB	
SSF	047	02	03	82	16/30	003	108	220	WDB	
SSF	047	07	03	82	17/00	011	109		WDB	
SSF	047	03	03	82	11/00	203	110	831	WDB	
SSF	047	03	03	82	09/15	011	111	43	WDB	

Table O-6. Operational data, total coliform, standard plate count, Giardia, dissolved oxygen, and particle data computer coding for Phases II and III.

TANK	DATE DY/MO/YR	TURB NTU	TEMP °C	FLOW ML/HR	DIFF PRES CM	SAMPLE NO.	COLIF NO./ML	HEIR BACT NO./ML	GIARDIA NO./L	DO PPM	PART N/PMAL
TANK	21 2 82	6.7				PFT182	66500	775			
FILT 1	24 2 82	6.7	16.5	142	2.0	PFT177	750	685		8.0	
FILT 2	24 2 82	6.7	16.5	142	2.5	PFT178	1700	860		8.0	
FILT 3	24 2 82	6.2	16.5	145	5.3					8.1	
FILT 4	24 2 82	4.1	16.5	143	24.3	PFT179	16	70		5.6	
FILT 5	24 2 82	7.1	5.0	145	1.5	PFT180	16000	145		7.9	
FILT 6	24 2 82	7.7	5.0	144	3.2	PFT191	20000	280		7.9	

\*\* Number of tanks per day may vary

Table O-7. Giardia data analysis worksheet, all phases.

GIARDIA CYST "MERATION							Slaw Lanza
Run Number	Sample Number	Analysis Date/Time	Amt. Water Conc. In Sample	Sample Count	Analysis by	Comments	
R86, 87, 88	65	8/9/82	Conc. 4.5 L 1800 cyst/L	1100 1100 1100 (1150)	CAH	del. to 1:5 Same as other conc.	
R86, 87, 88	66	8/9/82 3:00 pm	Conc. 6 L 1000 cyst/L	1000 1100 1100 (1100)	CAH	del. to 1:5. coccidia oocyst amoebas debris, pollen, DE. Some as other conc.	
R86	67	8/10/82 10:00 am	—	0	CAH	faucy cells, amorphic material, nematode, fide, rotifer all layers from 10u DE printing under - fungal	
R87	67	11:00 am 8/10/82	—	0	CAH	Same as R86 67	
R86	68	11:15 am 8/10/82	—	0	CAH	Same as R86 67	
R87	68	11:30 am 8/10/82	—	0	CAH	pollen, oocyst very dirty del to del. to a 1:5. rotifer nematode, and by cyst-like debris fungal bodies. 10u - like debris	
R88	68	11:30 am 8/10/82	8 cent thru expected	400 1000 (100)	CAH	very many fungal bodies - del. to del. 1:5. nematode, oocyst, debris material - all layers from 10u rotifer. Cyst in del. stage.	
R89, 90, 91	61	12:00 pm 8/10/82 1:00 pm	1000 cyst/L Conc. 9 L	1700 1300 1000 (1500)	CAH	del. to 1:5 water intake is amorphic material plant and debris, algae, nematode fungal bodies	

Table O-8. Total coliform data analysis worksheet, all phases.

TOTAL COLIFORM ANALYSIS SHEET  
SLOW SAND FILTRATION

RUN NUMBER	SAMPLE NUMBER	ANALYSIS START		No. Mls SAMPLE FILTERED	COUNT (colonies) AT INCUBATION (hr)				RESULTS REPORTED (no./100ml)	ANALYSIS BY (initials)	COMMENTS
		TIME	DATE		24	48	72	96			
9899 100	2	8	9/29	1					1900	OH	
				100	17						
9899 100	4	1540	9/29	1					2400	OH	
				100	24						
98	6		9/30	10					55	OH	
				100	4						
99	6		9/30	10					275	OH	
				100	29						
100	6		9/30	10					185	OH	
				100	18						
9899 100	5		9/30	1					3200	OH	
				100	29						

Table O-9. Standard plate count data analysis worksheet, all phases.

TOTAL PLATE COUNT  
ANALYSIS SHEET  
(SLOW SAND FILTRATION)

RUI# NUMBER	SAMPLE NUMBER	ANALYSIS START		No. (mls) SAMPLE ANALYZED	COUNT (colonies) AT INCUBATION (hr)				RESULTS REPORTED (no./ml)	ANALYSIS BY (initials)	COMMENTS
		TIME	DATE		24	48	72	96			
88	7	1:50	8/5	.1 .01		27 3			270	OH	
86 87 88	6	1:00	8/5	.01 .001 .0001		107 10 1			10,700	OH	
86	8	1:30	8/6	.1 .1 .01		16 12 3			110	BH	
87	8	1:10	8/6	.1 .01		41 A			410	BH	
88	8	1:30	8/6	.1 .01		23 2			230	DHN	



Table O-10. Particle count data analysis worksheet, all phases.

PARTICLE COUNT RESULTS

Date \_\_\_\_\_  
 Sample Rate \_\_\_\_\_

Run No. _____ Sample No. _____ Vol. Conc. _____ (L)					Run No. _____ Sample No. _____ Vol. Conc. _____ (L)			
Ch	Bkgnd. Count	Avg. Count	Net Count	Count (No./10ml)	Bkgnd. Count	Avg. Count	Net Count	Count (No./10ml)
1								
2								
3								
4								
5								
6								
7								
8								
9								
10								
11								
12								
13								
14								
15								
16								
Time								

Run No. _____ Sample No. _____ Vol. Conc. _____ (L)					Run No. _____ Sample No. _____ Vol. Conc. _____ (L)			
Ch	Bkgnd. Count	Avg. Count	Net Count	Count (No./10ml)	Bkgnd. Count	Avg. Count	Net Count	Count (No./10ml)
1								
2								
3								
4								
5								
6								
7								
8								
9								
10								
11								
12								
13								
14								
15								
16								
Time								

$$\frac{\text{Count}}{10\text{ml}} = \left[ \frac{\text{Vol W.W.}}{10\text{ml} \times \text{Vol. Conc.}} \right] \left[ \frac{260\text{ml}}{\text{Time} \times \text{Flow}} \times \text{Count} \right] \times \frac{1\text{L}}{100}$$

Vol W.W. in ml, Vol. Conc. in L, Time in sec, Flow in ml/sec

Table O-11. Equipment list and experimental variable record, Phase I.

EQUIPMENT LIST AND EXPERIMENTAL VARIABLES SLOW SAND FILTRATION (SSF)				Date
				8-8-82
EQUIPMENT	Model	Serial No.	Mode of Operation	Run Number
UNP				
PUMP PRESSURE GAUGE	RFD	117063	SSF	090
FILTER TANK THERM.	7380-22	9	SSF	090
FILTER	6	2	SSF	090
FILTER THERMOMETER	4320	102	SSF	090
FILTER PRESSURE GAUGE	7380-22	9	SSF	090
FLOW METER	F1400	02134	SSF	090
TURBIDITY METER	18500	1018	SSF	090
FILTRATE TANK THERM.			SSF	
PH METER			SSF	
COULTER COUNTER			SSF	
VARIABLES				
TEMPERATURE	115 °C		SSF	090
HYDRAULIC LOADING	0.04 m/hr		SSF	090
SOURCE OF WATER <sup>1</sup>	HORS		SSF	090
WATER CONDITION <sup>2</sup>	NATR		SSF	090
GIARDIA FEED CONC.	1000 cysts / liter		SSF	090

<sup>1</sup> Source of Water  
 HORSE - Horsetooth Water  
 CITY - City Water

<sup>2</sup> Water Condition  
 NATR - Natural  
 FILT - Filtered  
 TURB - Added Turbidity

APPENDIX P

SYNTHETIC SEWAGE FORMULA

This appendix contains the formula for the nutrient mixture which was added to Filter 4 during the Phase II testing. The nutrients were added to increase the biological activity.

Table P-1 shows the synthetic sewage recipe used to add nutrients to slow sand Filter 4. This is a modified version of Pipers synthetic sewage recipe (1962).

Table P-1. Nutrient recipe for additon to slow sand Filter 4.

Chemical	Grams Added	Chemical Formula
Milk Solids	15.9	Milk Solids
Urea	1.59	Urea
$\text{KH}_2\text{PO}_4$	0.54	$\text{KH}_2\text{PO}_4$
$\text{K}_2\text{HPO}_4$	0.69	$\text{K}_2\text{HPO}_4$
$\text{KHCO}_3$	15.20	$\text{KHCO}_3$
$\text{MgSO}_4$	0.49	$\text{MgSO}_4 \cdot 7\text{H}_2\text{O}$
EDTA	0.40	EDTA
Fe	0.24	$\text{FeCl}_2 \cdot 6\text{H}_2\text{O}$
Zn	0.48	$\text{ZnCl}_2$
Mn	0.28	$\text{MnCl}_2 \cdot 4\text{H}_2\text{O}$
Cu	0.37	$\text{CuCl}_2 \cdot 2\text{H}_2\text{O}$
Co	0.25	$\text{CoCl}_2 \cdot 6\text{H}_2\text{O}$
B	0.18	$\text{H}_3\text{BO}_3$

Notes:

- 1) These chemicals are dissolved in 18 liters of distilled water and then autoclaved.
- 2) The nutrient mixture is added to Filter 4 in sufficient quantity to depress the D.O. approximately 2 to 5 ppm, i.e., at approximately 1 liter per day.