

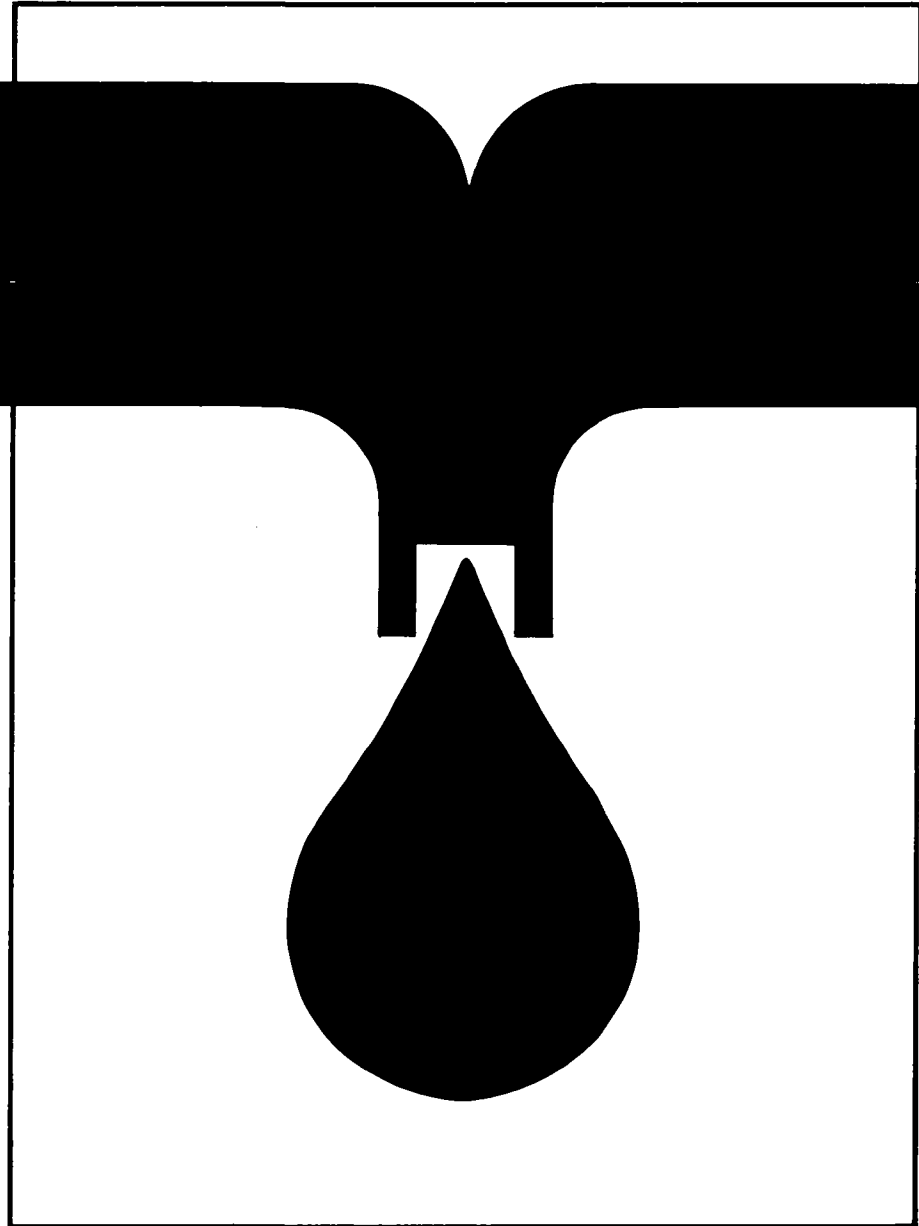

TRAINING MODULES FOR WATERWORKS PERSONNEL



Special Skills

3.3 e

Installation, operation, maintenance and repair of pumps

262.0-8137 g)

262.0 87TR (3)
8132

Foreword

Even the greatest optimists are no longer sure that the goals of the UN "International Drinking Water Supply and Sanitation Decade", set in 1977 in Mar del Plata, can be achieved by 1990. High population growth in the Third World combined with stagnating financial and personnel resources have led to modifications to the strategies in cooperation with developing countries. A reorientation process has commenced which can be characterized by the following catchwords:

- use of appropriate, simple and - if possible - low-cost technologies,
- lowering of excessively high water-supply and disposal standards,
- priority to optimal operation and maintenance, rather than new investments,
- emphasis on institution-building and human resources development.

Our training modules are an effort to translate the last two strategies into practice. Experience has shown that a standardized training system for waterworks personnel in developing countries does not meet our partners' varying individual needs. But to prepare specific documents for each new project or compile them anew from existing materials on hand cannot be justified from the economic viewpoint. We have therefore opted for a flexible system of training modules which can be combined to suit the situation and needs of the target group in each case, and thus put existing personnel in a position to optimally maintain and operate the plant.

The modules will primarily be used as guidelines and basic training aids by GTZ staff and GTZ consultants in institution-building and operation and maintenance projects. In the medium term, however, they could be used by local instructors, trainers, plant managers and operating personnel in their daily work, as check lists and working instructions.

45 modules are presently available, each covering subject-specific knowledge and skills required in individual areas of waterworks operations, preventive maintenance and repair. Different combinations of modules will be required for classroom work, exercises, and practical application, to suit in each case the type of project, size of plant and the previous qualifications and practical experience of potential users.

Practical day-to-day use will of course generate hints on how to supplement or modify the texts. In other words: this edition is by no means a finalized version. We hope to receive your critical comments on the modules so that they can be optimized over the course of time.

Our grateful thanks are due to

Prof. Dr.-Ing. H.P. Haug
and
Ing.-Grad. H. Hack

for their committed coordination work and also to the following co-authors for preparing the modules:

Dipl.-Ing. Beyene Wolde Gabriel
Ing.-Grad. K. H. Engel
Ing.-Grad. H. Hack
Ing.-Grad. H. Hauser
Dipl.-Ing. H. R. Jolowicz
K. Ph. Müller-Oswald
Ing.-Grad. B. Rollmann
Dipl.-Ing. K. Schnabel
Dr. W. Schneider

It is my sincere wish that these training modules will be put to successful use and will thus support world-wide efforts in improving water supply and raising living standards.

Dr. Ing. Klaus Erbel
Head of Division
Hydraulic Engineering,
Water Resources Development
Eschborn, May 1987



Title: Installation, operation, maintenance and repair of pumps

| Table of contents: | | Page |
|--------------------|--|------|
| <u>1</u> | <u>Installation of centrifugal pumps</u> | 2 |
| 1.1 | Erection | 2 |
| 1.2 | Alignment of pump and prime mover | 3 |
| 1.3 | Connection of pipes | 4 |
| 1.4 | Coupling protection | 7 |
| <u>2</u> | <u>Startup/commissioning, shutdown</u> | 8 |
| 2.1 | Preparatory work | 7 |
| 2.1.1 | Lubricants | 7 |
| 2.1.2 | Shaft seals | 8 |
| 2.1.3 | Priming | 9 |
| 2.1.4 | Checking direction of rotation | 9 |
| 2.2 | Starting | 9 |
| 2.3 | Stopping | 10 |
| <u>3</u> | <u>Supervision of operation and maintenance</u> | 10 |
| 3.1 | Supervision of operation | 10 |
| 3.2 | Maintenance | 13 |
| 3.2.1 | Maintenance of bearings | 13 |
| 3.2.2 | Maintenance of shaft seals | 14 |
| <u>4</u> | <u>Repairs (taking a single-stage, horizontal, low-pressure centrifugal pump as example)</u> | 16 |
| 4.1 | Dismantling | 16 |
| 4.2 | Re-assembly | 22 |
| 4.2.1 | General points | 22 |
| 4.2.2 | Detailed assembly | 23 |
| 4.3 | Cross-section with list of parts | 26 |

1 Installation of centrifugal pumps

Centrifugal pumps can only run smoothly if they are installed with care and properly serviced. It is therefore essential to ensure that the operating instructions, which are usually supplied together with the pump, are followed, and that the machine is not used for any other than the intended application, or under other than the specified conditions. As a rule, the operating instructions do not include safety regulations, since these differ from country to country. The user of the pump is responsible for ensuring that whatever regulations are in force are strictly observed by both permanent staff and specialist personnel brought in to install the equipment.

When moving the pump and motor about before final installation, ropes should be attached to pump and motor as shown in fig. 1 (and not to the eye ring on the motor!).

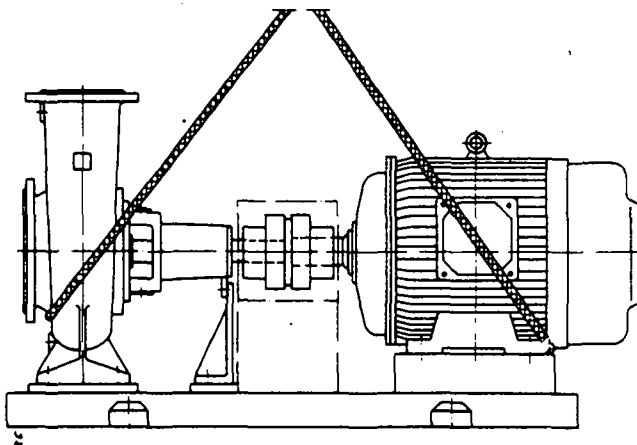

Fig. 1: Pump and prime mover mounted on a common base plate

1.1 Erection

The concrete foundation must have set properly before the equipment is mounted. Its surface must be horizontal and level. The complete unit is aligned with a spirit level

(on the shaft/delivery side) when it is erected on the prepared foundation. The distance between the two halves of the coupling, as given in the table of directions for erection supplied by the manufacturer, must be carefully observed. Shims must always be positioned directly next to the attaching elements between the base plate/foundation frame and the foundation structure. If the distance between the attaching elements is greater than 800 mm, additional shims must be provided at middle distance between them. All shims must be in full contact with the surface of the foundation.

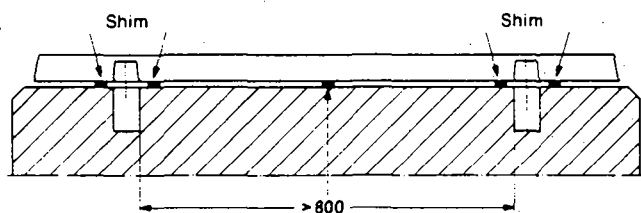

Fig. 2: Positioning of shims

The next step is to tighten the screws evenly and firmly. Then the base plate is sealed with mortar (non-shrink), avoiding the formation of cavities.

1.2. Alignment of pump and prime mover

When the base plate is firmly in position, the coupling has to be carefully checked and, if necessary, the pump re-aligned with the prime mover.

Inspection of the coupling and re-alignment are still necessary even if the pump and the prime mover were supplied mounted on a common base plate and already aligned.

The pump is properly aligned if a ruler laid axially over both halves of the coupling is seen to be equally far from each shaft all the way round, whilst turning the point of measurement.

In addition, both halves of the coupling must be the same distance from each other round the complete circumference. This is checked with feeler or gauge. The difference between the two parts of the coupling should not be more than 0.1 mm in the radial or in the axial plane (cf. figs. 3 and 4).

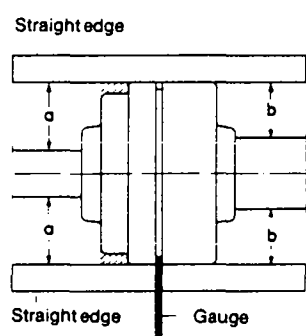

Fig. 3: Alignment of elastic coupling without intermediate sleeve

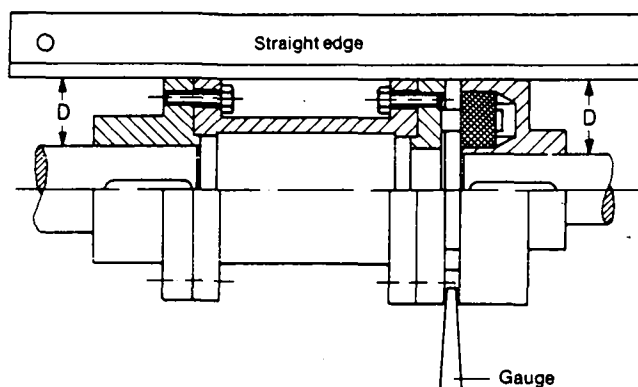

Fig. 4: Alignment of elastic coupling with intermediate sleeve

1.3 Connection of pipes

The pump must on no account be used as a fixed point for the pipework.

The suction pipe is installed sloping upwards to the pump; gravity pipes slope downwards.

A support for the pipe must be provided shortly before it reaches the pump, and the connection made without stress. The weight of the pipe must not rest on the pump.

Fig. 5: Correct connection of the suction pipe

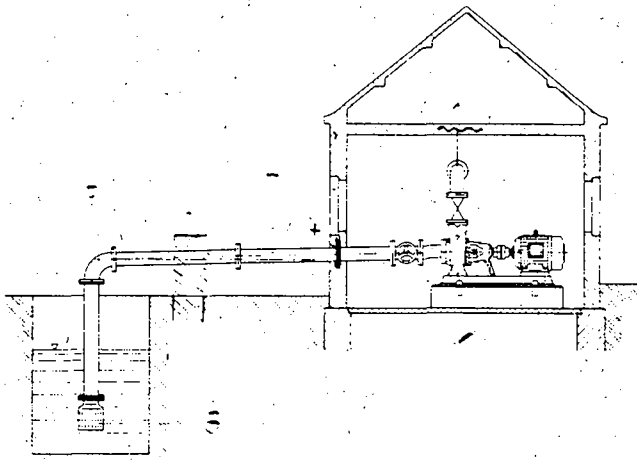

- 1 = Ceiling anchor, to support suction pipe
- 2 = Eccentric bridging piece (concentric would lead to air pocket formation)
- 3 = Stop valve (valve spindle horizontal or pointing down)
- 4 = Wall flange to support pipe
- 5 = Suction pipe, sloping upwards

6 = Support for suction or discharge pipe, e.g. concrete

7 = Normal pipe elbows only are used, sharp bends must be avoided

8 = The foot valve with suction strainer is installed 0.5 m below the lowest water level and 0.5 m above the bottom, so that neither air nor grit/mud can be drawn in

The nominal diameter of the pump's suction flange is not decisive for the diameter of the suction pipe. The flow speed in the suction pipe should if possible not exceed 2 m/s. As a basic rule, every pump should have its own suction pipe. If circumstances do not allow this, the suction pipe must be dimensioned for speeds as low as feasible, if at all possible with a uniform diameter up to the final pump.

Sharp bends and sudden alterations of cross-sectional area and direction must be avoided. It must be ensured that the seals between the flanges do not project inwards.

An air relief pump can be installed instead of a foot valve at the end of the suction pipe. A suction strainer is still necessary in this case, however, to stop foreign bodies entering the pump.

A stop valve must be installed in gravity feed pipes, so that intake can be interrupted to allow inspection of the pump.

Gravity feed pipes should always slope slightly downwards to the pump, to prevent the formation of air pockets.

All connecting pipes must be flushed clean to stop globules from welding, scale and similar contaminants getting into the pump.

Similarly, dimensioning of the discharge pipe is also not dependent on the nominal diameter of the discharge flange. Flow speed in the discharge pipe should not exceed 3 m/s. Sharp bends and branches should, if possible, be avoided here too. At pressure heads greater than 15 m, or where pipes are relatively long, installation of a non-return valve is recommended. This cushions pressure surges if the pump stops running suddenly, thus protecting pump and foot valve. Installation of a sluice valve is necessary to allow adjustment of the required rate of flow and isolation of the pump from the system whenever required.

As has already been pointed out, before new equipment is taken into service, all tanks, pipes and connections must be thoroughly cleaned and flushed, possibly also blown through. Often, however, contaminants such as globules are only detached after a comparatively long time. These are prevented from entering the pump through the installation of a strainer in the suction pipe. The free cross-sectional area must be equal to three times the cross-sectional area of the pipe, so that no excessive resistances can arise due to foreign matter caught by the strainer.

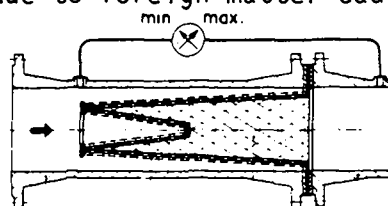

- 1 = Strainer holder
- 2 = Strainer
- 3 = Perforated plate
- 4 = Pump intake

Fig. 6: Strainer installed in suction pipe

1.4 Coupling protection

For reasons of safety, the pump unit may only be operated if the coupling is provided with a protective cover. This must adequately cover all rotating parts accessible to the hand or fingers.

2 Startup/commissioning, shutdown

2.1 Preparatory work

The alignment of the pump as described under 1.2 should be checked again briefly. It must be possible to rotate the coupling easily by hand. All pipe connections must be inspected to ensure that they are satisfactory.

2.1.1 Lubricants

Grease-lubricated bearings are normally already filled by the manufacturer of pump or motor. Only the level of the filling then has to be checked.

If the bearings are oil-lubricated - which is relatively rare nowadays - the oil in the appropriate reserve container on the relevant part of the machine is topped up. A suitable grade is nearly always an automotive oil of the specification SAE-20 (HD 20).

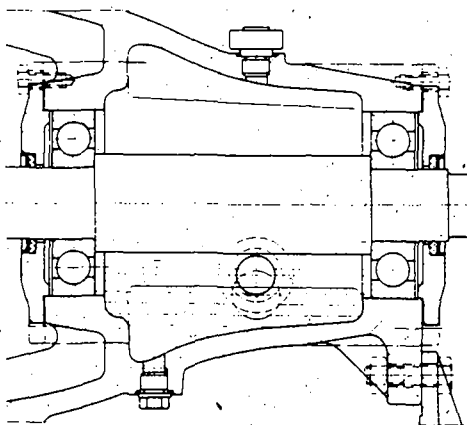

Fig. 7: Oil-lubricated bearings

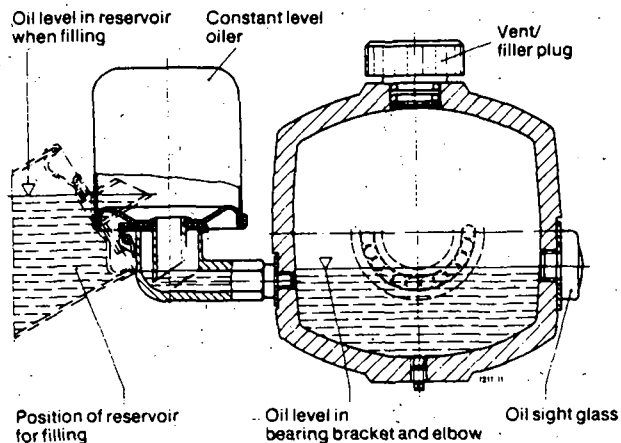

Fig. 8: Oil levels with constant level oiler

2.1.1 Shaft seals

Check whether the stuffing-box gland is evenly and lightly tightened. Excessive or uneven tightening leads to overheating and can damage the shaft sleeve. In the case of smaller pumps with a low power requirement, the result may be overloading of the prime mover. The pumping unit may have been supplied without a shaft seal; if so this must be installed.

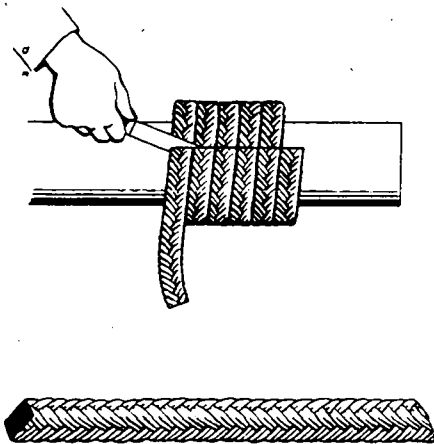

Fig. 9: Cut length
of packing ring

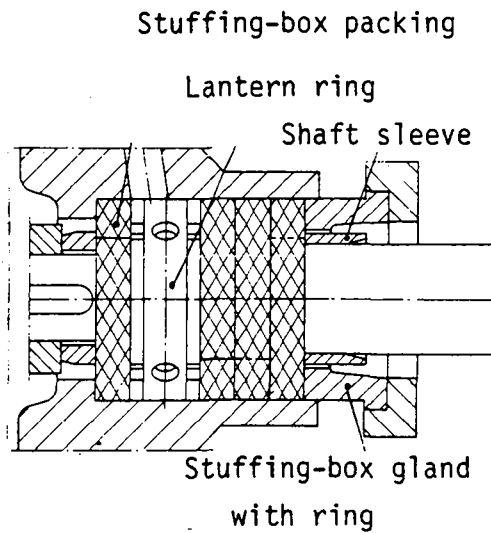

Fig. 10: Positioning of packing
rings (joints staggered by 90°)

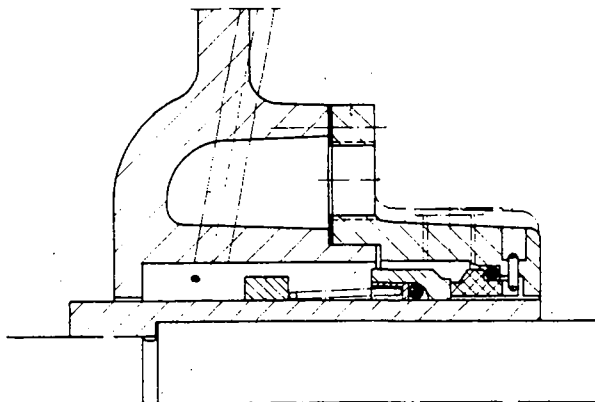

Fig. 11: Mechanical seal version

2.1.3 Priming

Pump and suction pipe must be ventilated and filled with fluid before starting. The stop valve in the suction pipe must be fully open.

Piston pumps are self-priming. Filling of the pump cylinder before starting the pump for the first time is always advisable (less wear on piston and stuffing-box), and often necessary.

The pump's permanent readiness for operation depends largely on the foot valve. This must be checked before installation for water-tightness, using a pressure of approx. 5 bars. Its upper flange or connecting thread must be approx. 0.5 m below the lowest possible level in the well, so that no air can be drawn in. On the other hand, it should not be so near the bottom that mud or sand is disturbed and sucked into the pipe.

All additional connected pipes (sealing liquid, flushing liquid for the shaft seal, etc.) should be fully opened and checked to ensure that they are clear.

Pumps with slide-ring seals must not under any circumstances be operated without first filling them with fluid, even for a brief trial run, since this destroys the seal.

2.1.4 Checking the direction of rotation

The direction of rotation must correspond to the direction of the arrow on the pump. This is checked by switching the pump on and then quickly off again. Where the pump is driven with alternating current and the direction of rotation is wrong, correct by changing over two phases.

Re-mount protective cover of coupling.

2.2 Starting

The pump may only be switched on when the stop valve on the discharge side is closed. This is then slowly opened



when the pump has reached its full speed and finally adjusted to the correct operating position.

Note that this is true of centrifugal pumps only! When displacement pumps are switched on, the stop valve on the discharge side must be completely open.

2.3 Stopping

Close the stop valve in the discharge pipe (centrifugal pumps only!).

If there is a non-return valve (flap valve) in the discharge pipe, the stop valve may remain open, provided there is counter-pressure.

Switch off the prime mover and allow it to run down.

Where pumps are out of service for a comparatively long period, the stop valve in the feed pipe should be closed. Close all other connected pipes.

If there is a risk of freezing and/or during longer periods out of service, the pump must be emptied or specially protected against freezing.

3 Supervision of operation and maintenance

3.1 Supervision of operation

The operation of every pump with its prime mover must be carefully supervised.

Attention should be paid to the following points:

The pump must run smoothly and without vibration. The water level in suction and intake tanks and the pressure on the suction side of the pump must be monitored. Loading of the equipment, shown by pump pressure or power consumption of the motor, should be compared with the data given on the rating plates. Stuffing boxes must be observed, especially during the running-in phase. If standby pumps are provided, these must be exchanged weekly to allow their readiness for operation to be checked.

Very important is also a check of the maximum permissible suction head. To clarify the concept "suction": in the case of fluid pumps, this means the lifting of a liquid above the free water level by means of external atmospheric pressure. Put more simply, a relative negative pressure, as compared with the surrounding atmospheric pressure acting on the liquid, is produced in the suction pipe. Thus the fluid is forced up the suction pipe by atmospheric pressure. Assuming an absolutely watertight piston and normal atmospheric pressure, a pump can thus theoretically suck cold water to a height of 10.33 m. In practice, absolutely watertight pistons, valves, stuffing boxes etc. are not possible. The attainable suction head (or "static suction lift") is thus lower; at most approx. 7 to 8 metres. However, the type and temperature of the liquid, position of the operating point in the case of centrifugal pumps and the installation height of the pump all have an effect on the suction head it can achieve.

As is generally known, atmospheric pressure decreases with height above sea level - and with it the possible static suction lift. Wherever the pump is installed at a height greater than 500 m above sea level, the reduced atmospheric pressure must be taken into account in calculating the static suction lift (cf. the graph below).

As was already pointed out, the temperature of the pumped fluid must also be taken into account. Theoretical calculations show that a certain vapour pressure, at which evaporation begins, belongs to every water temperature. If fluids with higher temperatures are to be lifted, the corresponding saturation pressure must not be exceeded (cavitation). This partial vapour pressure also becomes less with increasing installation height, however (cf. Table 1).

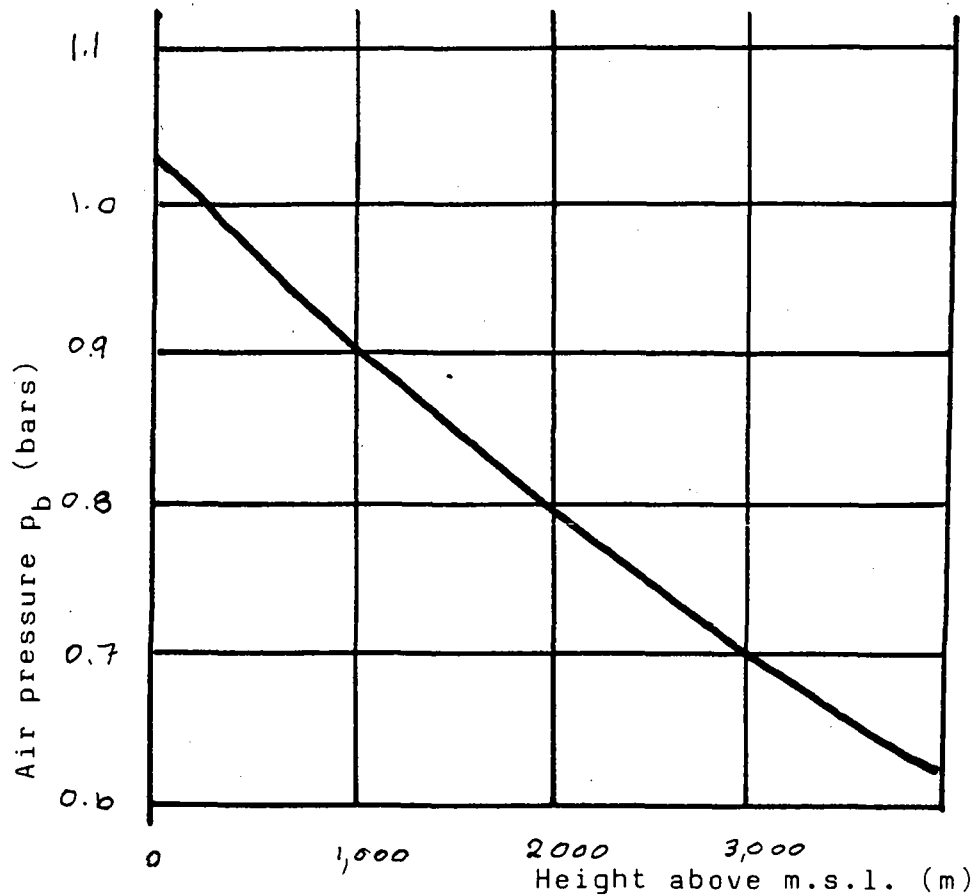

Fig. 12: Alteration of atmospheric pressure with increasing height above sea level

Table 1: Alteration of state with increasing height above s.l.

| Height above m.s.l. (m) | Temp. (°C) | Pressure (bars) | Partial vapour pressure water (bars) | Boiling point water (°C) |
|-------------------------|------------|-----------------|--------------------------------------|--------------------------|
| 0 | 15 | 1.0133 | 0.01706 | 100 |
| 0 | 14.3 | 1 | 0.01703 | 100 |
| 200 | 13.7 | 0.989 | 0.01573 | 99 |
| 1000 | 8.5 | 0.899 | 0.01106 | 97 |
| 2000 | 2 | 0.795 | 0.00705 | 93 |
| 3000 | -4.5 | 0.701 | 0.00413 | 91 |
| 4000 | -11 | 0.616 | 0.00239 | 87 |

A regular check should also be carried out on the pump's efficiency, to allow any wear inside it to be detected at an early stage. The simplest method is to measure pressure and volumes where performance data are known. If pressure gauges and a water meter are installed, the check can be performed by comparing the readings with the pump data, e.g. on the data plate. If there is no water meter, another method is to fill a receptacle having a known volume within a known time. Provision of a pressure gauge is essential, however.

In dry periods, note should be taken of the possible drop in the water level in a deep well. This means that a smaller amount of water is lifted at the same rotational speed, since the delivery head which the pump has to achieve is higher by the difference in the water level in the well. The deep well pump may possibly have to be lowered, i.e. if the water level drops below the installation depth.

Mention must be made again here of the possibility of affecting pump performance via the prime mover. Cage rotor engines with only one speed are not suitable for performance control without use of relatively sophisticated equipment, e.g. electronic control systems. The best-known and most frequently chosen possibility is use of internal combustion engines for speed control. It must be noted, however, that whereas, when the speed is increased, the amount pumped rises in a linear relationship with the speed, the delivery head increases quadratically and power requirement to the 3rd power.

3.2 Maintenance

3.2.1 Maintenance of bearings

Grease-lubricated bearings are usually already provided with a filling of grease which is adequate for approx. 3,000 operating hours, or a maximum of 2 years.

Under unfavourable operating conditions, e.g. high temperatures, sandstorms etc., roller (anti-friction) bearings must be inspected annually. The bearings are removed with the shaft and cleaned with wash oil. Under no circumstances may petrol or similar fluids be used. After cleaning, the bearings are again filled up with grease and replaced (cf. heading 4: Repairs). Suitable is a high-grade bearing grease on a lithium soap base, resin and acid free, non-friable and corrosion-preventive. The grease should have a penetration factor between 2 and 3, equivalent to a worked penetration of 220 to 295 mm/10. The dropping point should not be below 175°C.

Pumps or prime movers with oil-lubricated bearings are nearly always delivered with unfilled oil chambers. The oil chamber must be filled with oil before the equipment is put into operation for the first time. Oil-level eyes or oil-level control instruments are used to monitor the level of the oil. The oil filling of new roller (anti-friction) bearings must be renewed after approx. 300 hours of operation or at the latest at the end of 1 year. Generally speaking, all automotive oils of the specification SAE-20 are suitable. During inspections, the bearings should be thoroughly cleaned after removal. Following re-assembly, oil is again filled in up to the prescribed level.

A general rule for both types of bearing is that their temperature and running behaviour must be carefully observed during operation. Bearing temperatures up to 50°C above room temperature are admissible, but not higher than 90°C.

3.2.2 Maintenance of shaft seals

Where stuffing-box packings are provided, the stuffing box should always drip slightly in operation. If it is completely watertight, or even starts to smoke, the nuts of the stuffing-box screws must be loosened slightly.

When the packing has become compressed by about the width of one packing ring, it must be renewed. The condition of the shaft sleeve should be checked at the same time. This must be replaced if its surface shows marked scoring or roughness. Particular attention should be paid to using packing material of the right size. It is advisable to keep a supply in reserve.

The stuffing box can only function properly if it is carefully packed and regularly and correctly serviced. Before packing or re-packing, the recess, shaft and, where applicable, the shaft sleeve must all be thoroughly cleaned (c.f. also heading 4: Repairs). The packing rings should be cut smoothly at an angle at both ends, after measuring the correct length round the shaft sleeve. A tube or wooden rod with the same diameter can also be used. The ends of the packing ring should just touch (cf. also 2.1.2: Shaft seals). Before placing the packing rings in the recess, their contact surfaces should be coated with oil. Each ring is pushed down with the gland. The joints should be 90° further round each time.

The main components of a mechanical seal are two rings sliding on each other which are pressed together by a spring. Sealing against the shaft sleeve and sealing cover is achieved with the aid of O ring seals (cf. also 2.1.2: Shaft seals). The sealing of a mechanical seal takes place between the sealing surfaces in a very narrow axial space between a rotating and a stationary ring. Attainment of a long surface life depends on the sealing surfaces not being damaged. A certain leakage of this seal, up to continuous dripping, is admissible. Normally, however, leakage is limited to very slight, invisible amounts (vapour state). The temperature on the seal housing or the circulation pipe should not exceed 50°C. Maintenance of mechanical seals is restricted to monitoring of temperature and leakage.

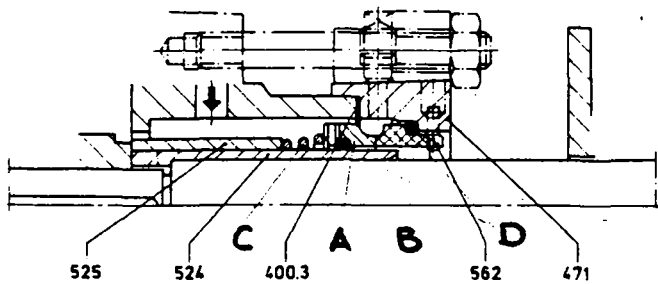

- 400.3 Gasket
- 471 Seal cover
- 524 Shaft sleeve
- 525 Spacer tube (sleeve)
- 562 Cylindrical pin
- A Rotating slide ring
- B Stationary slide ring
- C Spring
- D O-ring seals

Fig. 13: Mechanical seal

4 Repairs (taking a single-stage, horizontal low-pressure centrifugal pump as example)

The numbers given in brackets after the pump components refer to the list of parts in the cross-sectional drawing at the end of this module.

4.1 When dismantling the unit, the volute (102) can remain on the base plate and attached to the pipework. In the case of units with intermediate sleeve couplings, the prime mover also remains fixed to the base plate (cf. fig. 14). Only the intermediate sleeve of the coupling is removed. Where installed, cooling or sealing liquid tubes are detached.

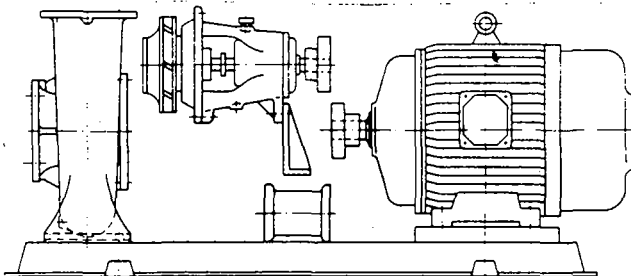

Fig. 14: Unit with intermediate sleeve coupling

Where the unit has a normal coupling, the prime mover is detached and removed from the base plate (fig. 15).

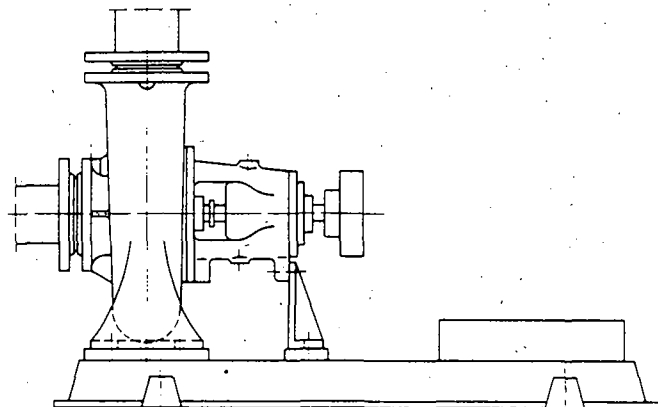

Fig. 15: Motor removed from base plate (normal coupling)

Detach supporting leg (183) from the base plate. Loosen nuts (920.1) of the casing screws (902.1) - fig. 16.

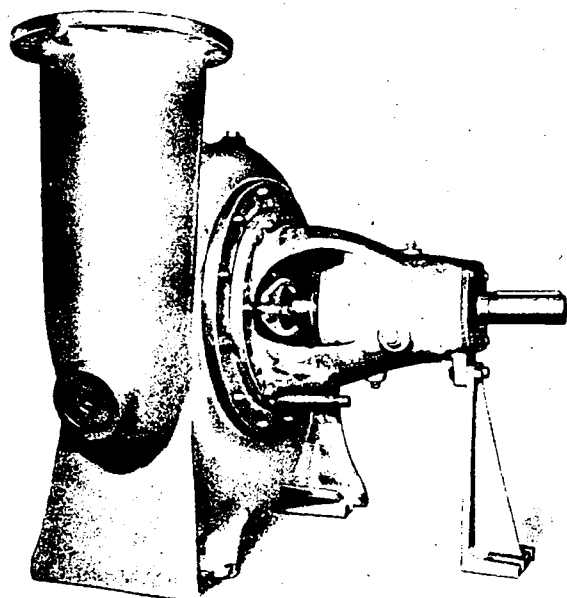

Fig. 16: Loosen hexagonal nuts of casing screws

Take out bearing bracket (330) with pressure cover (163) and complete impeller (fig. 17).

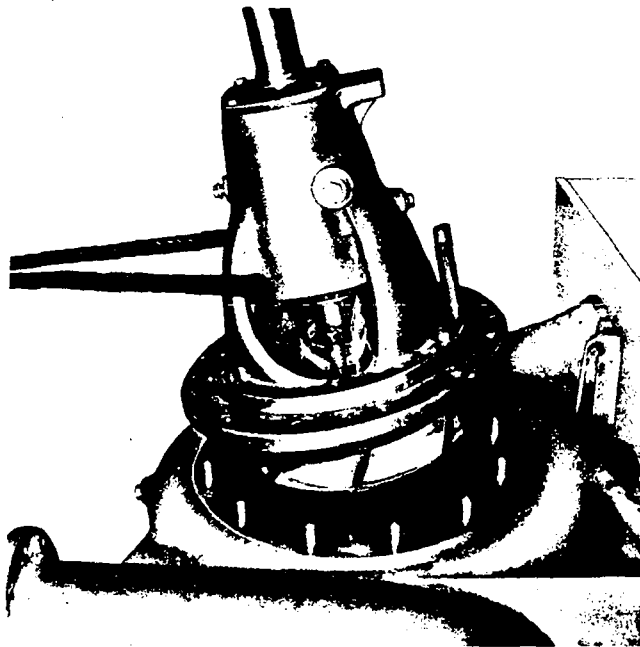

Fig. 17: Removal of bearing bracket

Loosen hexagonal nuts (920.5 or 914), remove all component parts holding the impeller on the shaft (210) and push impeller (230) off the shaft (210) - fig. 18.

Take out keys.

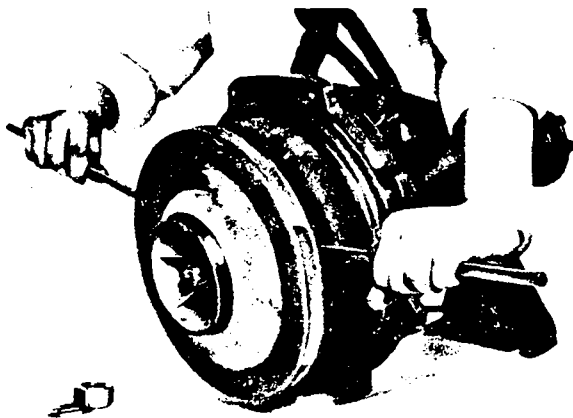

Fig. 18: Removal of impeller

If there is a mechanical seal, the attaching screws (920.4) of the seal cover (471) are removed and the seal cover carefully pushed off the pressure cover (163) together with the stationary parts of the mechanical seal.

Loosen hexagonal screws (920.2) of the stuffing-box gland (452.1) and push the gland towards the bearing bracket. Remove stuffing-box packing (461.1).

Press pressure cover (163) out of the centering of the bearing bracket (330) (using thrust screws) and remove from the shaft (210) - fig. 19.

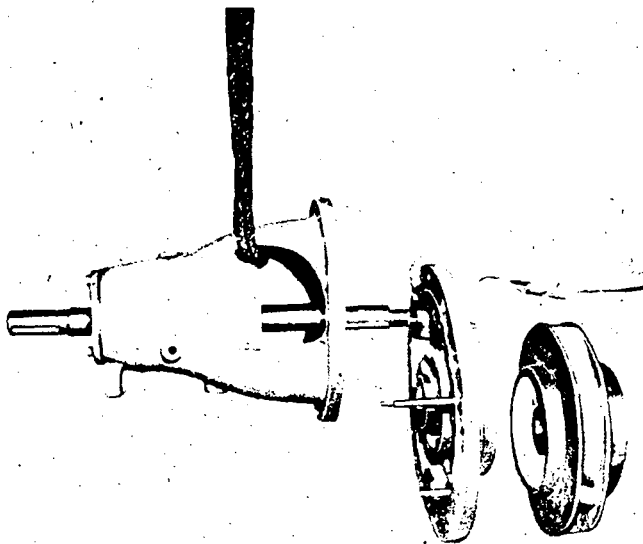

Fig. 19: Removal of pressure cover

Take off shaft sleeve (524) and thrower (507). If a mechanical seal is used, the shaft sleeve (523) is taken off the shaft (210) together with the rotating parts of the mechanical seal.

Carefully remove seal cover (471) from the shaft and check carbon ring (475) for damage.

Remove the half of the coupling on the pump side using a normal detaching device (fig. 20); do not drive it off the shaft (210).

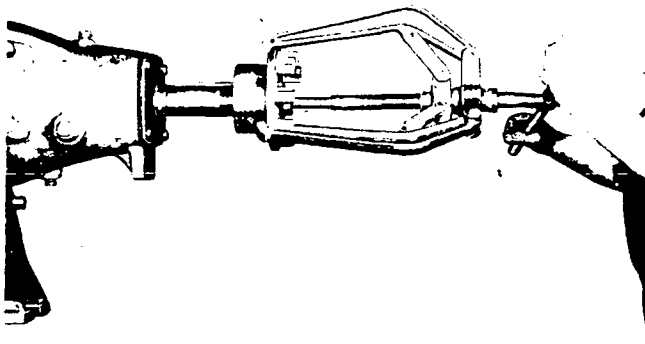

Fig. 20: Removal of coupling half

Remove both bearing covers (360) - fig. 21.

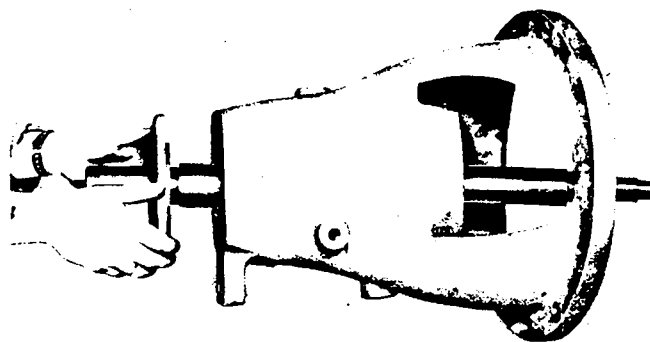

Fig. 21: Removal of bearing cover

With light taps, drive shaft (210) with grooved ball bearings (321) carefully out of the bearing bracket (330) - fig. 22.

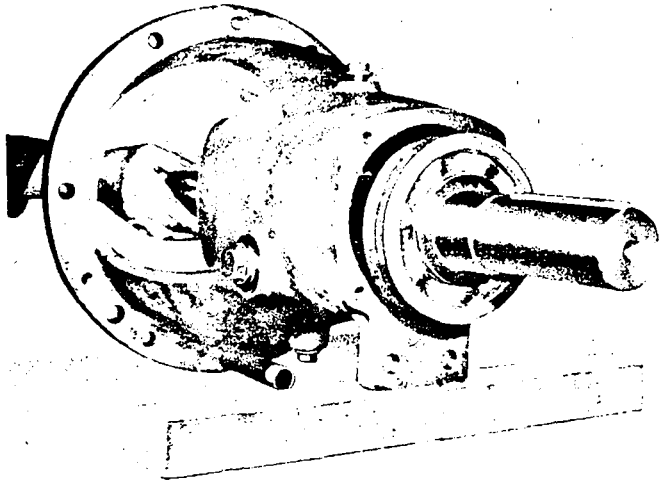

Fig. 22: Driving the shaft out of the bearing bracket

Remove grooved ball bearings (321), including Nilos rings (500.1) from the shaft (210) - fig. 23.

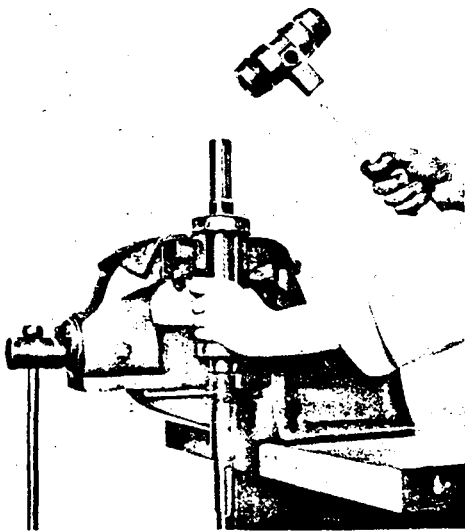

Fig. 23: Removal of ball bearings from the shaft

After dismantling, all parts must be carefully cleaned and checked for signs of wear. Damaged parts (e.g. wear rings) should be replaced (worn parts may possibly be re-worked). Any deposits on the volute (102), pressure cover (163) or impeller (230) must be removed.

4.2 Re-assembly

4.2.1 General points

In partial or full re-assembly of the pump, the following general points must be noted:

All sealing elements (gaskets, O ring seals, Nilos rings where applicable) must be exchanged.

If new grooved ball bearings are necessary, they must first be heated to approx. 80°C and then placed on the shaft. Absolute cleanliness is essential!

Fill bearings with grease or bearing bracket with oil.

If the sealing part between impeller neck and wear ring (502) is worn and the sealing gap has a clearance greater than 0.8 mm (=1.6 mm in diameter), new wear rings must be installed in the volute (102) or pressure cover (163). The new wear ring (502) is installed as shown in fig. 24. If necessary, the impeller (230) should be re-balanced. Then the under-dimensioned wear rings (502) are installed in the bore. The new clearance between wear ring and impeller is 0.4 mm in diameter and is produced by working the wear ring, installed in the pressure cover, on a lathe.



Fig. 24: Installation of a wear ring

4.2.2 Detailed assembly

The pump is re-assembled in the opposite order to the dismantling process.

Clamp the shaft (210) firmly in a vice, taking care not to damage it. In the case of grease-lubricated bearings, position Nilos rings (500.1) on the shaft and the shaft shoulders. Sometimes unilaterally closed bearings are used; these rings are then not required.

Heat grooved ball bearings (321) in an oil bath to approx. 80°C, push onto the shaft and position them together with the Nilos rings at the shaft shoulders (fig. 25). Check correct positioning at the shaft shoulders as the bearings cool. In the case of oil lubrication, the grooved ball bearings are mounted on the shaft in the same way, but without the Nilos rings.

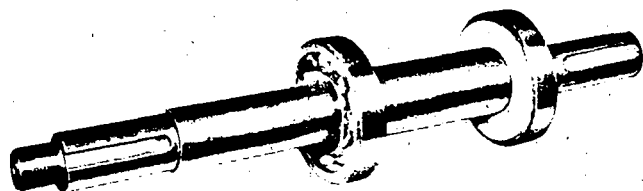

Fig. 25: Mounted grooved ball bearings

Mounting the shaft (210) in the bearing bracket (330) takes place in the opposite direction to dismantling (fig. 26).

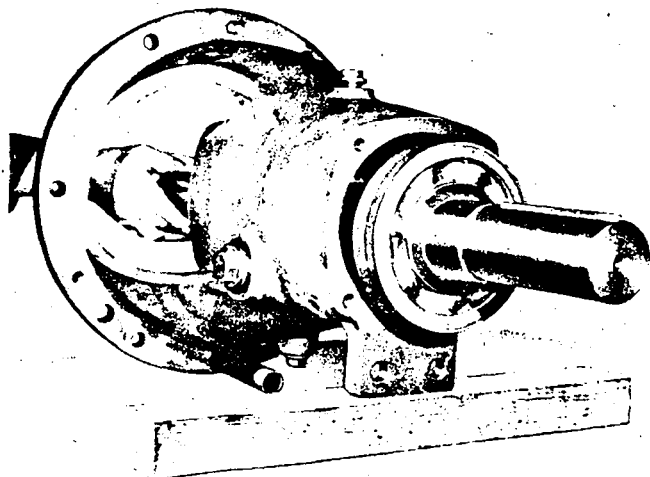

Fig. 26: Mounting the shaft in the bearing bracket

Mount the bearing covers (360) with gasket (400.4) on both sides of the bearing bracket (330) - fig. 27.

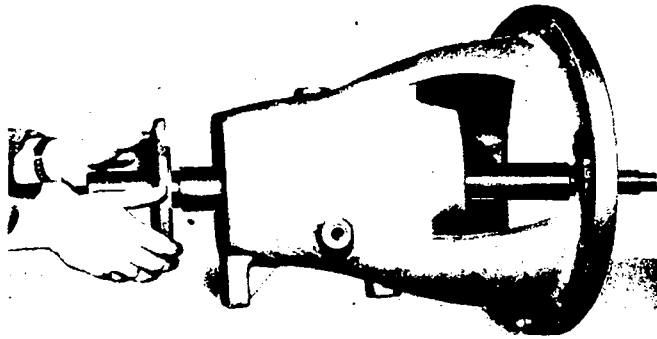

Fig. 27: Mounting of bearing cover

Push thrower (507) over the shaft up to just before the bearing cover.

Place stuffing-box gland (452.1) loosely over the shaft. When a mechanical seal is used, place seal cover (471) with carbon ring (475) and gasket (400.5) carefully over the shaft. Push shaft sleeve (523) with adjusted rotating parts of the mechanical seal over the shaft (adjusting dimensions of the mechanical seal are given by the supplier).

Place gasket (400.3) on the bearing bracket (330). Push pressure cover (163) onto the centering of the bearing bracket (fig. 28).

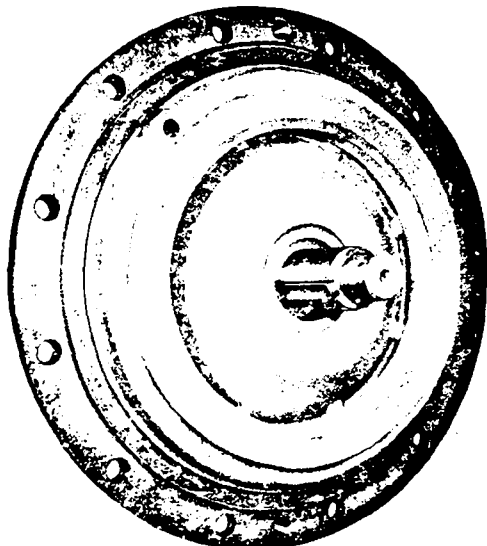

Fig. 28: Assembled
pressure cover

Place gasket (400.1) in shaft sleeve (524) and push up shaft until positioned on shaft shoulder.

Lay key (940.1) in the shaft and mount impeller (230). If a mechanical seal is used, carefully tighten seal cover (471) crosswise against the pressure cover (163) whilst slowly turning shaft, to prevent canting of the sealing parts.

Tighten impeller with nut (920.5) up to shaft sleeve (524) and secure with securing plate (931). Mount complete bearing bracket in volute (102) - fig. 29.

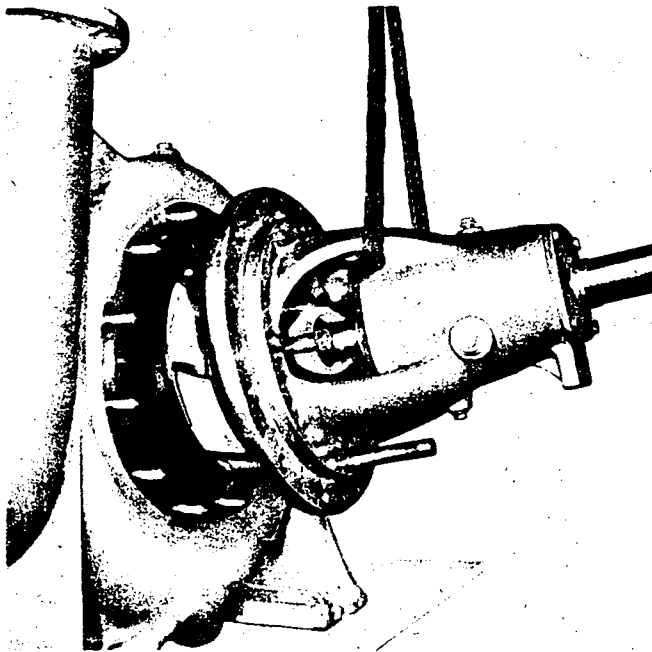
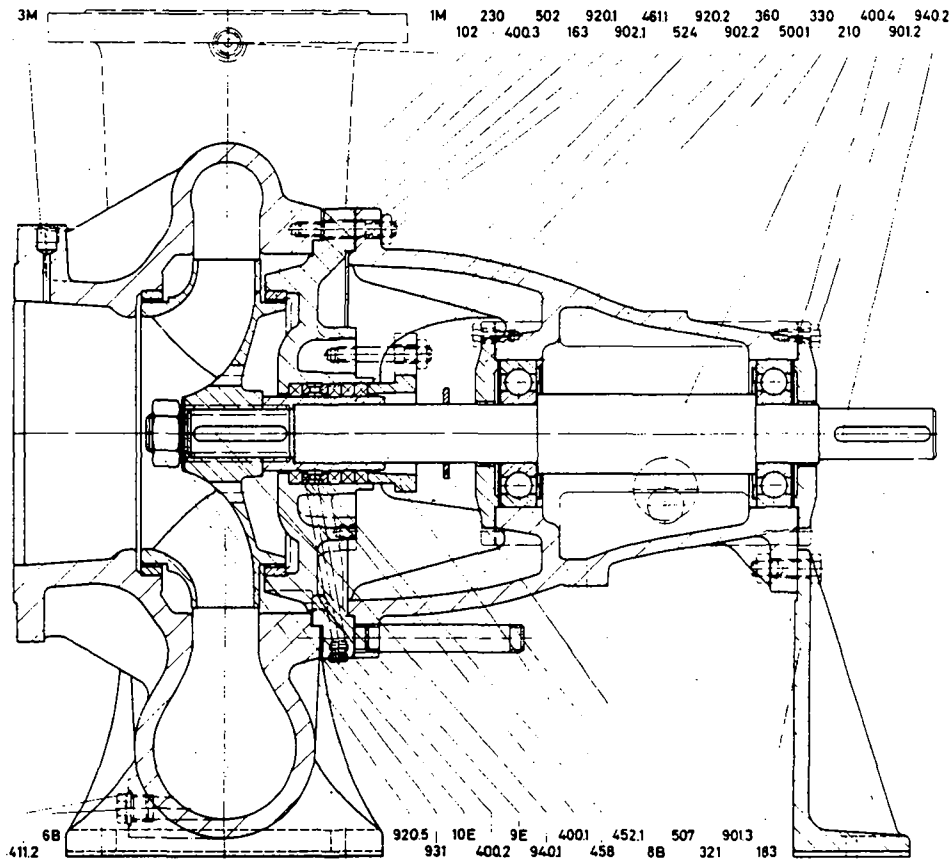

Fig. 29: Mounting of bearing bracket

Pack stuffing-box, align unit and take into operation.

4.3 Cross-section with list of parts





| Part no. | Nomenclature |
|----------|---------------------------------------|
| 102 | Volute casing |
| 163 | Pressure cover |
| 183 | Supporting leg |
| 210 | Shaft |
| 230 | Impeller |
| 321 | Grooved ball bearing |
| 330 | Bearing bracket |
| 360 | Bearing cover |
| 400.1 | Gasket |
| 400.2 | Gasket |
| 400.3 | Gasket |
| 400.4 | Gasket |
| 411.2 | Washer |
| 452.1 | Stuffing-box gland |
| 458 | Lantern ring |
| 461.1 | Stuffing-box packing |
| 500.1 | Nilos ring |
| 502 | Wear ring |
| 507 | Thrower |
| 524 | Shaft sleeve |
| 901.2 | Hexagon-head screw |
| 901.3 | Hexagon-head screw |
| 902.1 | Stud |
| 902.2 | Stud |
| 920.1 | Hexagonal nut |
| 920.2 | Hexagonal nut |
| 920.5 | Nut |
| 931 | Securing plate |
| 940.1 | Key |
| 940.2 | Key |
| 1 M | Connection for pressure gauge |
| 3 M | Connection for manometer vacuum gauge |
| 6 B | Drain |
| 8 B | Leakage drain |
| 9 E | Sealing liquid inlet: internal |
| 10 E | Sealing liquid inlet: external |

Recommended parts to be kept in stock are marked



Deutsche Gesellschaft für Technische Zusammenarbeit (GTZ) GmbH

Dag-Hammarskjöld-Weg 1 + 2 · D 6236 Eschborn 1 · Telefon (0 6196) 79-0 · Telex 407 501-0 gtz d

The government-owned GTZ operates in the field of Technical Cooperation. Some 4,500 German experts are working together with partners from some 100 countries in Africa, Asia and Latin America in projects covering practically every sector of agriculture, forestry, economic development, social services and institutional and physical infrastructure.

- The GTZ is commissioned to do this work by the Government of the Federal Republic of Germany and by other national and international organizations.

GTZ activities encompass:

- appraisal, technical planning, control and supervision of technical cooperation projects commissioned by the Government of the Federal Republic of Germany or by other authorities
- advisory services to other agencies implementing development projects
- the recruitment, selection, briefing and assignment of expert personnel and assuring their welfare and technical backstopping during their period of assignment
- provision of materials and equipment for projects, planning work, selection, purchasing and shipment to the developing countries
- management of all financial obligations to the partnercountry.

The series "**Sonderpublikationen der GTZ**" includes more than 190 publications. A list detailing the subjects covered can be obtained from the GTZ-Unit 02: Press and Public Relations, or from the TZ-Verlagsgesellschaft mbH, Postfach 36, D 6101 Roßdorf 1, Federal Republic of Germany.

TRAINING MODULES FOR WATERWORKS PERSONNEL

List of training modules:

Basic Knowledge

- 0.1 Basic and applied arithmetic
- 0.2 Basic concepts of physics
- 0.3 Basic concepts of water chemistry
- 0.4 Basic principles of water transport
- 1.1 The function and technical composition of a watersupply system
- 1.2 Organisation and administration of waterworks

Special Knowledge

- 2.1 Engineering, building and auxiliary materials
- 2.2 Hygienic standards of drinking water
- 2.3a Maintenance and repair of diesel engines and petrol engines
- 2.3b Maintenance and repair of electric motors
- 2.3c Maintenance and repair of simple driven systems
- 2.3d Design, functioning, operation, maintenance and repair of power transmission mechanisms
- 2.3e Maintenance and repair of pumps
- 2.3f Maintenance and repair of blowers and compressors
- 2.3g Design, functioning, operation, maintenance and repair of pipe fittings
- 2.3h Design, functioning, operation, maintenance and repair of hoisting gear
- 2.3i Maintenance and repair of electrical motor controls and protective equipment
- 2.4 Process control and instrumentation
- 2.5 Principal components of water-treatment systems (definition and description)
- 2.6 Pipe laying procedures and testing of water mains
- 2.7 General operation of water main systems
- 2.8 Construction of water supply units
- 2.9 Maintenance of water supply units Principles and general procedures
- 2.10 Industrial safety and accident prevention
- 2.11 Simple surveying and technical drawing

Special Skills

- 3.1 Basic skills in workshop technology
- 3.2 Performance of simple water analysis
- 3.3a Design and working principles of diesel engines and petrol engines
- 3.3b Design and working principles of electric motors
- 3.3c –
- 3.3d Design and working principle of power transmission mechanisms
- 3.3e Installation, operation, maintenance and repair of pumps
- 3.3f Handling, maintenance and repair of blowers and compressors
- 3.3g Handling, maintenance and repair of pipe fittings
- 3.3h Handling, maintenance and repair of hoisting gear
- 3.3i Servicing and maintaining electrical equipment
- 3.4 Servicing and maintaining process controls and instrumentation
- 3.5 Water-treatment systems: construction and operation of principal components: Part I - Part II
- 3.6 Pipe-laying procedures and testing of water mains
- 3.7 Inspection, maintenance and repair of water mains
- 3.8a Construction in concrete and masonry
- 3.8b Installation of appurtenances
- 3.9 Maintenance of water supply units Inspection and action guide
- 3.10 –
- 3.11 Simple surveying and drawing work



Deutsche Gesellschaft für
Technische Zusammenarbeit
(GTZ) GmbH

P. O. Box 5180
Dag-Hammarskjöld-Weg 1+ 2
D 6236 Eschborn/Ts. 1
Telephone (06196) 79-0
Telex 407 501-0 gtz d
Fax No. (06196) 79-1115