

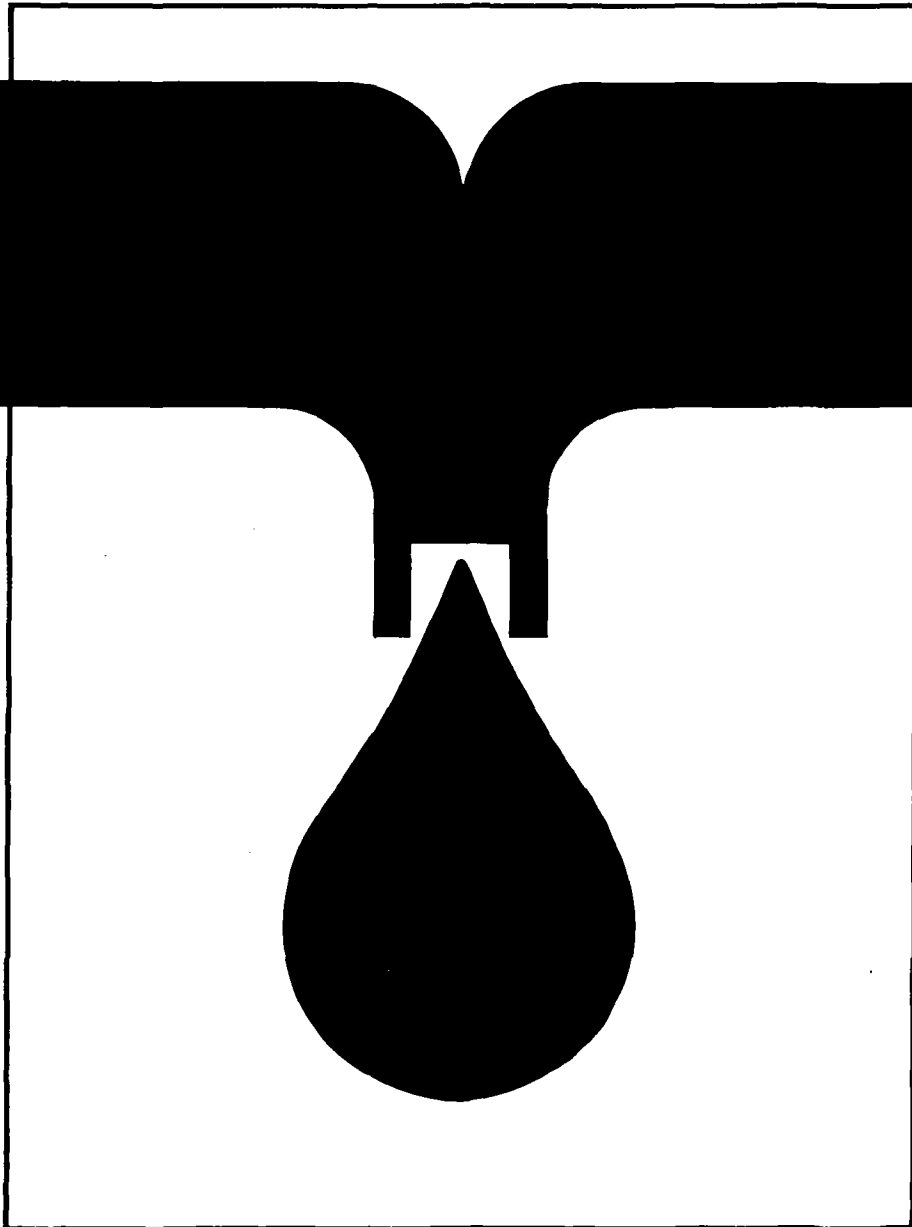

TRAINING MODULES FOR WATERWORKS PERSONNEL



Special Knowledge

2.6

Pipe laying procedures and testing of water mains

262.0-8132 99

8132
262.0 87TR (2)



Foreword

Even the greatest optimists are no longer sure that the goals of the UN "International Drinking Water Supply and Sanitation Decade", set in 1977 in Mar del Plata, can be achieved by 1990. High population growth in the Third World combined with stagnating financial and personnel resources have led to modifications to the strategies in cooperation with developing countries. A reorientation process has commenced which can be characterized by the following catchwords:

- use of appropriate, simple and - if possible - low-cost technologies,
- lowering of excessively high water-supply and disposal standards,
- priority to optimal operation and maintenance, rather than new investments,
- emphasis on institution-building and human resources development.

Our training modules are an effort to translate the last two strategies into practice. Experience has shown that a standardized training system for waterworks personnel in developing countries does not meet our partners' varying individual needs. But to prepare specific documents for each new project or compile them anew from existing materials on hand cannot be justified from the economic viewpoint. We have therefore opted for a flexible system of training modules which can be combined to suit the situation and needs of the target group in each case, and thus put existing personnel in a position to optimally maintain and operate the plant.

The modules will primarily be used as guidelines and basic training aids by GTZ staff and GTZ consultants in institution-building and operation and maintenance projects. In the medium term, however, they could be used by local instructors, trainers, plant managers and operating personnel in their daily work, as check lists and working instructions.

45 modules are presently available, each covering subject-specific knowledge and skills required in individual areas of waterworks operations, preventive maintenance and repair. Different combinations of modules will be required for classroom work, exercises, and practical application, to suit in each case the type of project, size of plant and the previous qualifications and practical experience of potential users.

Practical day-to-day use will of course generate hints on how to supplement or modify the texts. In other words: this edition is by no means a finalized version. We hope to receive your critical comments on the modules so that they can be optimized over the course of time.

Our grateful thanks are due to

Prof. Dr.-Ing. H. P. Haug
and
Ing.-Grad. H. Hack

for their committed coordination work and also to the following co-authors
for preparing the modules:

Dipl.-Ing. Beyene Wolde Gabriel
Ing.-Grad. K. H. Engel
Ing.-Grad. H. Hack
Ing.-Grad. H. Hauser
Dipl.-Ing. H. R. Jolowicz
K. Ph. Müller-Oswald
Ing.-Grad. B. Rollmann
Dipl.-Ing. K. Schnabel
Dr. W. Schneider

It is my sincere wish that these training modules will be put to successful use and will thus support world-wide efforts in improving water supply and raising living standards.

Dr. Ing. Klaus Erbel
Head of Division
Hydraulic Engineering,
Water Resources Development
Eschborn, May 1987

Title: Pipe laying procedures and testing of water mains

Table of contents:	Page
<u>1. Design</u>	2
1.1 Drawings and plans	2
1.2 Routing of water mains	4
1.2.1 General points	4
1.2.2 Long distance transmission pipelines	4
1.2.3 Trunk and service mains	5
1.3 Calculation of pipe diameters	5
1.3.1 General points	5
1.3.2 Volume of water	5
1.3.2 Supply pressure	6
1.3.4 Economic rate of flow	6
<u>2. Pipes</u>	7
2.1 Pipe materials	7
2.1.1 General points	7
2.1.2 Cast-iron pipes and joints	7
2.1.3 Steel pipes and joints	9
2.1.4 Asbestos cement pipes and joints	10
2.1.5 Plastic pipes and joints	10
2.1.6 Fittings	11
2.2 Valves, instruments	12
2.2.1 Stop valves	12
2.2.2 Public taps	12
2.2.3 Hydrants	13
2.2.4 Air Supply / relief valve	13
2.2.5 Drains and wash outs	14
2.2.6 Transfer points	14
<u>3. Excavation work and pipe-laying</u>	15
3.1 Digging and backfilling of trenches	15
3.2 Preparation of trench floor	15
3.3 Laying of pipes	16



4.	<u>Calculation of thrust blocks</u>	17
4.1	General points	17
4.2	Calculation of shearing force	17
4.3	Thrust blocks for pipe ends.	18
4.4	Thrust blocks for pipe bends.	19
5.	<u>Pressure test</u>	21
6.	<u>Flushing and sterilization</u>	22

1 Design

1.1 Drawings and plans

Just as in other technical fields, drawings play an important part in the design and construction of pipe systems. Their main functions are to pass on data to other specialists, to provide information for all interested parties and to establish for future reference a record of the exact location of the water mains and fittings laid. The drawings should also be revised accordingly for any amendments, extensions etc. of the pipe systems. To make the drawings easier to read, a system of symbols and notations is used (cf. fig. 1). These stand for certain technical expressions and standard pipe components.

The table below gives some of the most commonly-used symbols. Figures 2 and 3 show sections of plans on which the routes of water mains are marked.

Fig. 1 The main symbols

DRAWING	SYMBOL	DESIGNATION	NOTATION
		SOCKET LENGTH + FLANGE CONNECT.	A
		SOCKET LENGTH + SOCKET CON.	B
		SOCKET LENGTH + SOCKET BRANCH	C
		SOCKET FLANGE + FLANGE FITTING	E
		FLANGE SPIGOT	F
		SOCKET ELBOW	I
		TEE	T
		DOUBLE SOCKET	U
		BLIND FLANGE	X

	MAIN WITH NOMINAL WIDTH + MATERIAL
	SLUICE VALVE
	HYDRANT
	RISER
	PRESSURE CONTROL VALVE
	NON-RETURN VALVE
	WATER METER
	AIR VALVE
	DRAIN WITH SLUICE VALVE
	WATER MAIN INSIDE SLEEVE

Fig. 2: Part of a lay-out plan, scale 1 : 2000.

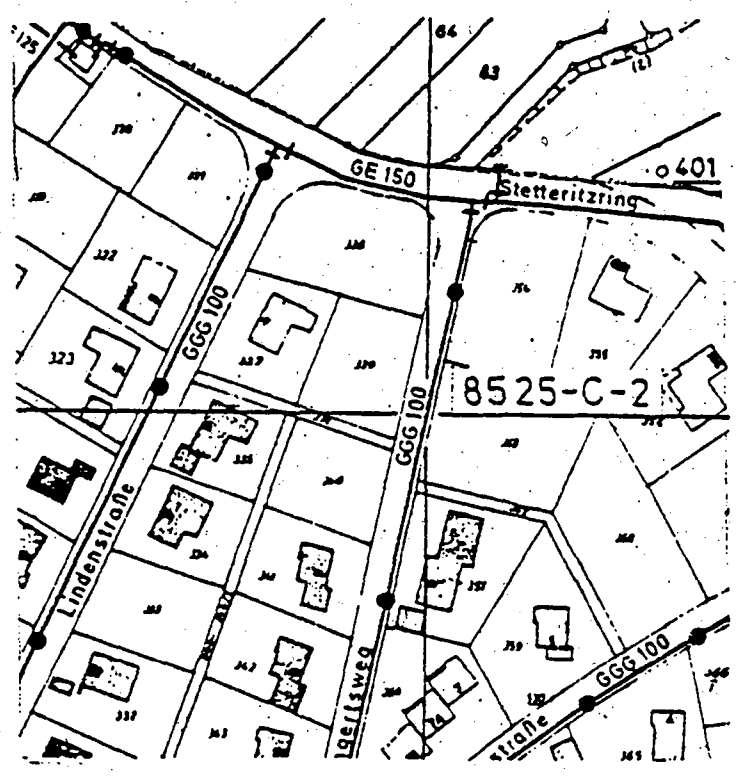

The plan shows:
 The route taken by the mains;
 Material and nominal internal diameter;
 Locations of stop valves and hydrants;
 Boundaries of plots, cadastral numbers, roads.

Fig. 3: Part of a location plan, scale 1 : 500

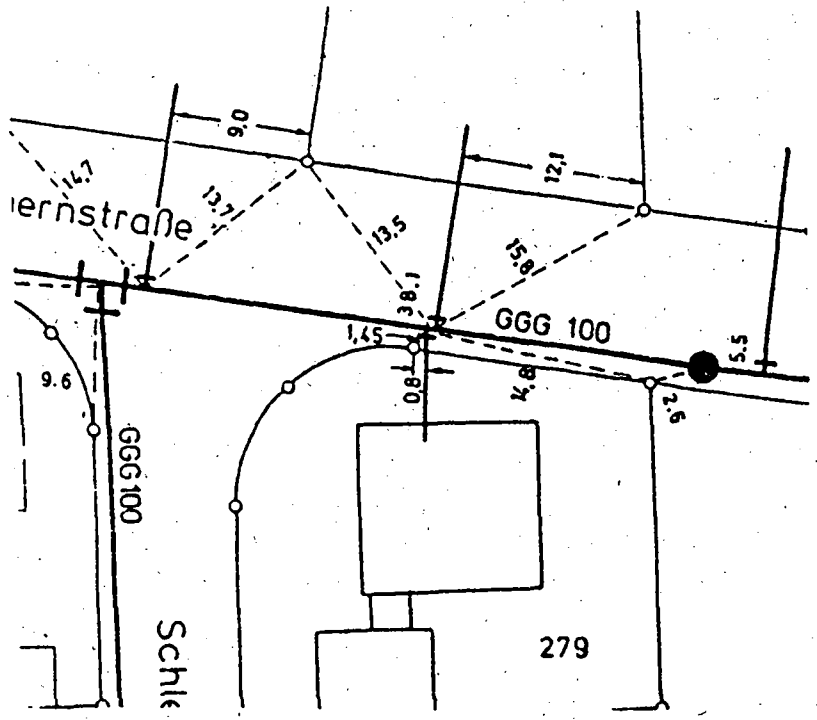

The location plan gives additional information on the locations of communication pipes and distances from fixed surveying points.

1.2 Routing of water mains

1.2.1 General points

At an early stage in the design of a pipe network system, the best route for the mains to take has to be determined after taking into consideration both the technical and economic aspects.

It seldom happens that the shortest possible path between two points is also simultaneously the optimum route. The factors determining this optimum route are not always the same, but vary according to whether long-distance transmission pipelines or water mains - service mains and communication pipes - are to be routed.

1.2.2 Long-distance transmission pipelines

Long-distance transmission pipelines are always routed outside built-up areas.

Mains of this category must be laid at an adequate distance away from surfaced roads, to allow for any subsequent road widening.

On steep gradient, the pipeline should be laid on a suitable line along the slope to ensure against damages due to landslide.

Wet or marshy ground should be avoided because of the risk of subsequent subsidence and of corrosion.

These mains should be laid with rising and falling gradients.

The gradients of the pipeline should not be less than 4⁰/∞. If pipelines are laid completely flat, air bubbles can form, leading to greater energy and pressure losses.

So that maintenance and repair work can be carried out, long-distance transmission pipelines must be accessible to motor vehicles.

These pipes should be laid in trenches to protect them from all external influences and frost. The thickness of the earth cover depends on climate.

1.2.3 Trunk and service mains

These are laid inside built-up areas, preferably underneath road reserves. Any other existing or planned facilities - e.g. electricity cables, gas mains - must be taken into account. The water mains should be laid if possible in undisturbed ground.

Ring mains with as few dead ends as possible are preferable.

The depth below ground level depends on climate and on the anticipated volume of traffic.

A minimum gradient of 4 ‰ is important here too. Air is released from the high points via communication pipes.

Trunk and service mains are best laid at mid-distance between the centre of the road and the boundaries of building plots when it is not possible to lay them in the road reserve.

Communication pipes should follow the shortest possible route from service main to water meter and should be equipped in such a way that a reserve flow from the draw-off points back to the service main is restricted.

1.3 Calculation of pipe diameters

1.3.1 General points

The choice of diameter depends on the volume of water to be transported, the economic rate of flow and the required minimum pressure.

1.3.2 Volume of water

The volume of water to be transported is calculated by considering the size of the area to be supplied, the population density and the specific water consumption per inhabitant per day. The decisive factor is the maximum hourly consumption. The needs of large-scale consumers such as hospitals, schools or industry and also requirements for fire-fighting purposes must be given separate consideration.

The specific water consumption of a population varies widely. The average consumption in Germany, for instance, is approx. 140 l per person per day; for rural areas in Africa the existential minimum requirement is assumed to be 40 l/person per day.

1.3.3 Supply pressure

The supply pressure in the service mains should be between 2 and 6 bars, representing a head of 20 to 60 m.

1.3.4 Economic rate of flow

The economic rate of flow is used to calculate the optimum relationship between construction, investment and operating - mainly energy - costs. Both construction and operating costs are largely determined by the diameter of the pipes.

The relationships are as follows:

Large pipe diameter - higher construction costs - low pressure losses in the mains - lower energy consumption.

The economically optimum rate of flow is given when:

The annual sum of the costs of energy, capital servicing and maintenance gives the lowest figure.

Economic flow rates must be calculated individually because of local and seasonal fluctuations in construction and energy costs.

General rule:

Trunk, secondary and service mains	1.00 m/sec
Long-distance transmission pipelines	1.40 m/sec

2 Pipes

2.1 Pipe materials

2.1.1 General points

Pipes are an indispensable means of transporting water. The laying, operation and servicing of a pipe network is more labour-intensive and requires more material than any other element of a water-supply system.

To ensure the smooth functioning of a pipe network, particular care must be taken to choose the right type of pipe, made of the most suitable material, for the application. It is true to say that as a general rule there is no ideal type of pipe which is equally suitable for all applications in a water-supply system.

The choice of material should always be made according to the specific conditions existing on site.

Basic information on pipe materials is given in Module 2.1.

The most common types of pipe, pipe joints, fittings and materials are listed below, with an indication of their advantages/disadvantages and recommended applications.

2.1.2 Cast-iron pipes and joints

Cast-iron pipes are chiefly produced today from ductile cast-iron in lengths between 5.00 and 6.00 m.

Nominal internal diameters and pressure stages

Cast-iron pipes are produced in diameters of up to 1000 mm and can withstand very high pressure stages.

Material properties, protection

Good bursting strength, elasticity.

The pipes are available provided with a cement mortar lining and an external coating of zinc and pitch.

Joints and fittings

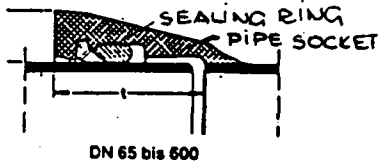

Fig. 4

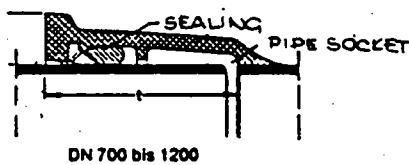

Fig. 5



Fig. 6

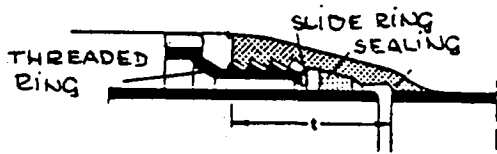

Fig. 7



Fig. 8

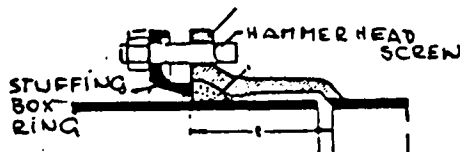

Fig. 9

Tyton joint (figs. 4, 5 and 6)

The Tyton sealing ring consists of a hard-rubber and a soft-rubber section. Tyton joints are simple in design and reliable in use. The joint can be bent through an angle of 3 to 6°.

Tyton joints are also used for pipes with larger diameters. For smaller pipe diameters up to DN 400, Tyton rings with vulcanized-in stainless-steel claws, which can transmit longitudinal force, are also available.

Screwed socket joint (figs. 7 and 8)

The inside of the socket and outside of the ring have a cast thread. The joint is sealed through a compression of the rubber seal by tightening the ring. Bending of the joint up to 3° is possible. Used up to DN 400. Does not transmit longitudinal force.

Stuffing-box joint (fig. 9)

The stuffing-box joint consists of a profiled rubber ring compressed by means of a hammerhead screw and a stuffing-box ring. Used mainly for larger diameters from DN 500 and for pipes without an earth cover. Bending up to 3° possible. Does not transmit longitudinal force.

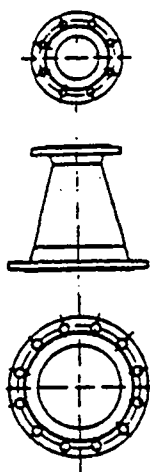

Fig. 10

Flange (fig. 10) and threaded joints

Both types of joint are rigid, withstand tensile stress and where pipes are laid underground are used only in combination with valves or instruments or in communication pipes.

The seal lies between the flanges and is compressed by tightening the screws.

Number and position of the drilled holes in the flange are standardized.

Recommended applications:

Pipes made from ductile cast iron are generally provided with Tyton joints. These pipes are easy to lay and reliable in use. Their use is widespread; special care must be taken only in the case of aggressive (untreated) water or aggressive soil, where measures must be taken to prevent corrosion.

2.1.3 Steel pipes and joints

Steel pipes are not used to any great extent in water-supply systems and are therefore given only brief mention here.

Advantages

High elasticity, few joints necessary, good bursting strength.

Disadvantages

Liable to corrode if not properly insulated; subsequent repairs to insulation difficult to carry out.

Welding of joints must be performed by competent, experienced workers.

2.1.4 Asbestos cement pipes and joints

Asbestos cement pipes are made of a mixture of asbestos fibres, cement and water and produced in lengths between 4.00 and 5.00 m. They are less resistant to shock and impact and have a lower flexural strength than steel or cast-iron pipes. Pipes made of asbestos cement are non-corroding and non-conductive. They are most economically used at pressures up to PN 10 and in diameters up to DN 600.

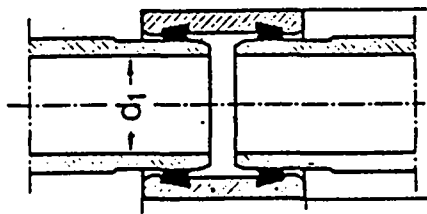

Fig. 11

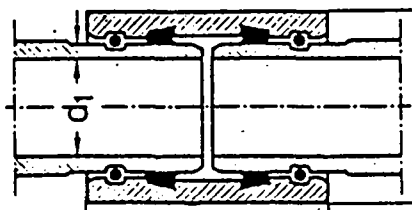

Fig. 12

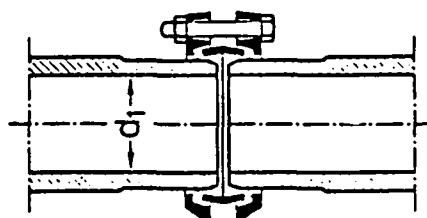

Fig. 13

Reka coupling (figs. 11 and 12)

Reka couplings are similar to double sockets. The calibrated spigot ends are inserted into the coupling from both sides. The spacer ring keeps the spigot ends apart. The seal is effected by sealing rings inserted on each side. Bending of the joint up to 6° is possible.

Reka couplings which can transmit longitudinal force are additionally secured by wire ropes (fig. 12).

Gibault coupling (fig. 13)

The Gibault coupling is made of steel with a profiled rubber sealing ring. Its advantage over the Reka coupling is that it can admit a wider range of tolerances.

2.1.5 Plastics pipes and joints

Plastics pipes used in water-supply systems are made mainly of rigid PVC (polyvinyl chloride) or PE (polyethylene). Both materials are non-corroding and non-conductive.

A disadvantage is their low resistance to material stresses under extreme temperature conditions, to impact and light. Pipes made from PVC are not suitable for above-ground applications (UV radiation causes embrittlement). In stony ground, plastics pipes should be well bedded in sand or suitable local material.

The use of PVC pipes is economical up to DN 300.

Pipes made from either rigid or flexible PE are used mainly for communication pipes.

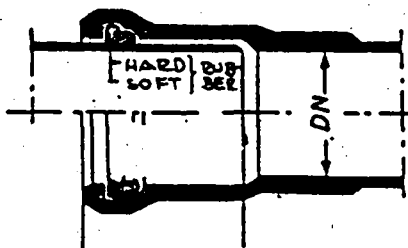

Fig. 14

The most commonly-used joint for PVC pipes is the socket with rubber sealing rings (fig. 14), similar to the Tyton joint described above.

PVC pipes can also be jointed with permanently adhesive sockets (fig. 15).

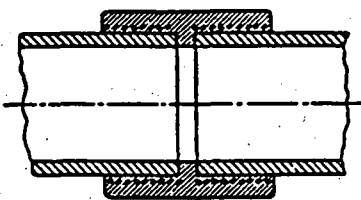

Fig. 15

PE pipes are supplied in lengths; smaller-diameter pipes in rolls.

PE pipes are jointed separably using compression or socket-and-spigot joints or permanently by welding.

(Fig. 16: compression joint).

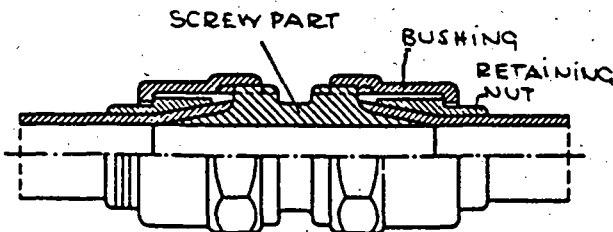

Fig. 16

2.1.6 Fittings

In pipe systems, it is often necessary to change direction, lay branches, install valves or instruments, increase or

reduce diameter, etc. There are special fittings available for all these purposes; they are given the same protection against corrosion as the pipes and provided with the appropriate connecting elements. Pipes made of different materials are connected together by means of transition fittings.

2.2 Valves, instruments

2.2.1 Stop valves

The task of stop valves is to allow or prevent, either completely or only partially, the passage of water through the main. The design of such valves varies quite widely (see Module 2.3g for details).

Stop valves in water mains are used chiefly

- to isolate certain sections of the main to allow repairs to be carried out or new branches to be connected,
- to regulate the flow of water,
- to permit the water to flow in one required direction only.

2.2.2 Public taps

In rural areas of developing countries, water is often distributed to consumers via publicly accessible taps (fig. 17). These taps should meet the following requirements:

Hygienic conditions must be maintained: drainage facilities for leakages or overflow water must be provided at the distribution point.

The structure should be solidly built of concrete or stone.

A sensible, practical design is important.

The water meter should be inaccessible to unauthorized persons.

Taps should be self-closing.

Fig. 17: Public tap

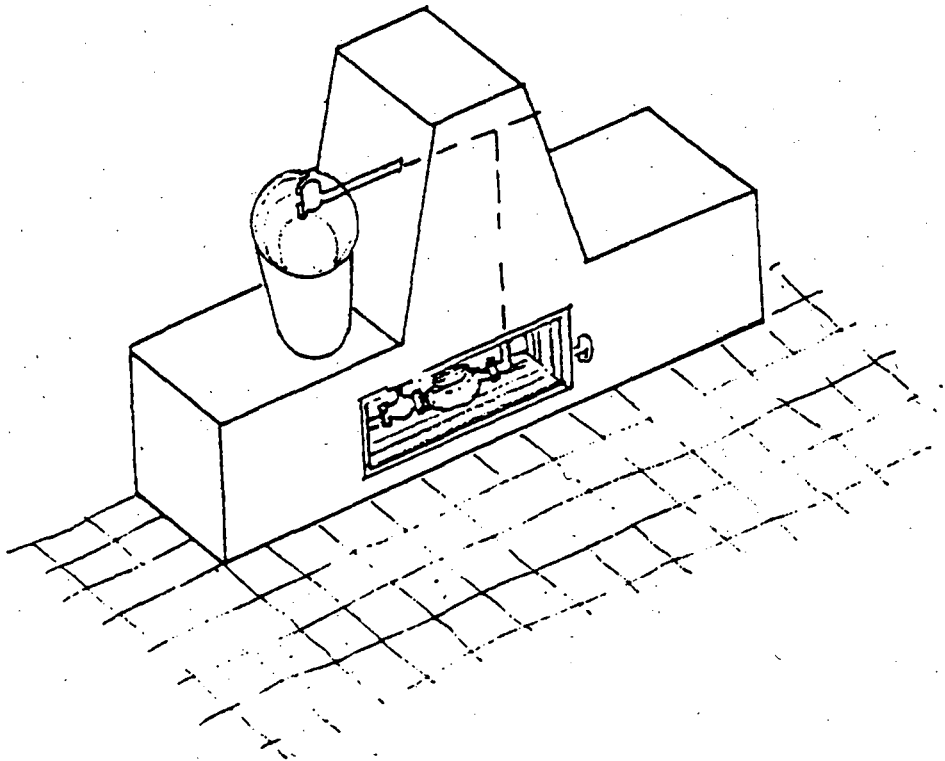

2.2.3 Hydrants

Hydrants are used for a temporary supply of water and for special purposes such as fire-fighting. Hydrants are also installed at the high and low points of water mains for drainage, flushing or the release of air.

2.2.4 Air supply/relief valves

The function of these valves in pipe systems is to

- let air in during the drainage process,
- release air during filling,
- allow air which has collected in the pipe during operation to escape.

Air valves are installed at high points and at sharp vertical bends.

In service mains, underground hydrants are used for the same purpose. Another possible method of releasing the air from the mains is to locate communication pipes at the high points.

Long-distance transmission and feeder mains are provided with *automatic air valves*. In *underground pipes* means that manholes have to be provided.

2.2.5 Drains and wash-outs

As already pointed out under 1.2, water mains should always be laid at a slope, to prevent air bubbles forming and so prevent the consequent risk of breakdowns. The low points in the pipe system which result are then provided with drain outlets.

The following points should be noted:

- drain outlets are installed at the lowest points of the pipe network;

- they are closed by means of a sluice valve;

- there should be a free flow zone between the drain outlet and the recipient ditch, stream or canal;

- no contaminants must be allowed to enter the water main through the drain outlet.

Drain outlets are often combined with wash-outs.

2.2.6 Transfer points

If local service mains are supplied from a transmission or feeder main, the point of transfer will usually be provided with the following:

- water meter

- non-return valve

- stop valve

- pressure-control valve

3 Excavation work and pipe-laying

3.1 Digging and backfilling of trenches

Before excavation of the pipe trench is begun, the axis of the pipe and its gradient must be transferred from the plan to the actual site. The pipe axis is marked from bend to bend and the correct gradient established to sight distance with the aid of sight rails.

Any already existing underground services such as drains, electricity mains, telephone cables etc. must be taken into account.

Depending on the stability of the ground, measures may have to be taken to prevent the sides of the trenches from collapsing inwards.

If there is enough space, the sides of the trench should be sloped, to an extent depending on the stability of the ground, or if space is limited they may be shored up using sheeting (cf. fig. 18). Materials, including excavated soil should be kept at least 1,5 metre from the edge of the trench.

Fig. 18: Methods of preventing collapse of trench sides

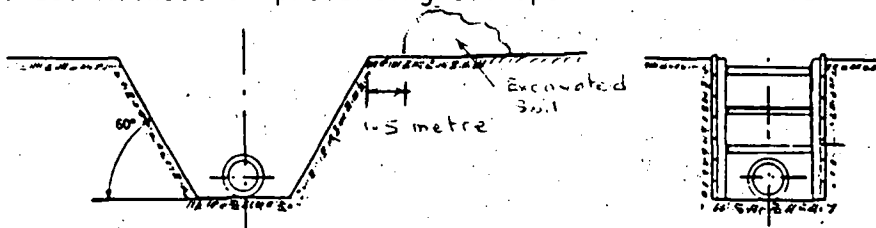

A minimum of 0.35 m working space is required on either side of the pipe.

3.2 Preparation of trench floor

In neutral, light soil (sand, gravel), the undisturbed ground should form the floor of the trench. In heavy soils (clay, rock), a bed of sand or suitable local material approx. 20 cm thick should be prepared for the pipe; the pipe should also be bedded in sand or suitable local material on all sides.

Where the ground is not firm enough, the floor of the pipe trench should be stabilized with a layer of crushed rock or coarse gravel.



The stabilizing layer and trench floor should then be compacted and covered with fine sand or suitable local material before the pipe is bedded.

The floor of the trench should slope evenly; the pipe must be in full contact with the ground at all points.

To ensure that the trench floor is even, appropriate checks should be carried out using sight rails.

The trench should be backfilled and compacted in layers of approx. 30 to 50 cm thick.

The material used in the proximity of the pipe should be stone-free and care must be taken not to damage the insulating layer.

3.3 Laying of pipes

When laying pipes, the following rules must be observed:

Pipes should be transported with care and sudden impacts avoided. Sharp-edged lifting and transporting aids such as chains or cables, should not be used.

Pipes made from PVC must not be exposed to sunlight for any length of time.

Before they are laid, the pipes should be inspected for faults; any imperfections in the protective coating should be repaired and extensively damaged pipes either rejected or shortened to their re-usable length.

Pipe joints should be cleaned with particular care.

The manufacturer's instructions must be followed throughout the pipe-laying process; this is especially important if joints are to be bent at an angle from the pipe axis.

There should always be a pipe brush inside the pipe; this is pulled through when a new length is fitted on.

During work breaks, all openings must be closed using plugs, covers, blank flanges etc.

Pipes must be protected against upthrust and against compressive stress by means of earth bridges.

4 Calculation of thrust blocks

4.1 General points

The forces occurring inside the pipe are sufficient to pull the joints apart at elbows, branches and pipe ends, if these cannot transmit longitudinal force. To prevent this from happening, such points are strengthened by thrust blocks, which are generally made of concrete. Calculation of the thrust blocks is based on the maximum pressure which can occur; usually during the test pressure of a pipe. It must be noted that the area of pressure taken for calculations is that of the outside diameter of a pipe (socket).

4.2 Calculation of shearing force

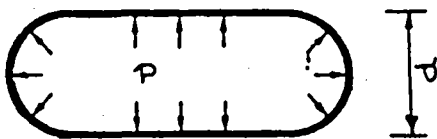

Fig. 19

The shearing force is calculated by the formula

$$P = \frac{p \times d^2 \times 3.14}{4} = \quad (\text{N})$$

where

P = shearing force in N (newtons)

p = maximum possible pressure in N/mm² (10 bars = 1 $\frac{\text{N}}{\text{mm}^2}$)

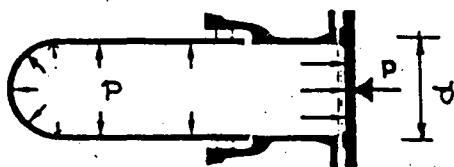

d = outside diameter

(cf. figs. 19 and 20)

Table 1 below gives the shearing forces calculated for the most commonly-used pipe diameters at a pressure of 15 bars (usual test pressure).

Table 1 Shearing force F 15 for a test pressure of 15 bars

DN	80	100	125	150	200	250	300	400
P15 (N)	11300	16400	24400	34000	58100	88400	125200	216800

4.3 Thrust blocks for pipe ends

The greater part of the shearing forces occurring in the pipe is transferred via a concrete foundation to the earth wall. In order not to exceed the permissible soil pressure, the area of pressure of the concrete abutment must be adequately dimensioned.

The surface area of the thrust block is calculated with the aid of the formula

$$A = \frac{P}{\delta} \text{ (mm}^2\text{)}$$

where

A = area of the thrust block in mm²

P = shearing force in N

δ = permissible soil pressure in N/mm²

Table 2 Permissible soil pressure for different types of subsoil

	bars	N/mm ²
Pasty ground =	0.4	0.04
Soft ground =	1.0	0.1
Semi-hard ground =	2.0	0.2
Hard ground =	4.0	0.4
Stratified rock =	15.0	1.5
Solid rock =	30.0	3.0

4.4 Thrust blocks for pipe bends

The shearing force which has to be absorbed by the thrust block wherever the pipe changes direction (i.e. at bends) is the resultant of two forces effective along the length of the pipe (cf. fig. 21).

The resultant is calculated with the aid of the formula

$$P_R = 2 \times P \times \sin \frac{\alpha}{2} \quad (\text{N})$$

where

P_R = resultant shearing force in N

P = shearing force (N)

α = angular deviation

Fig. 21: Parallelogram of forces

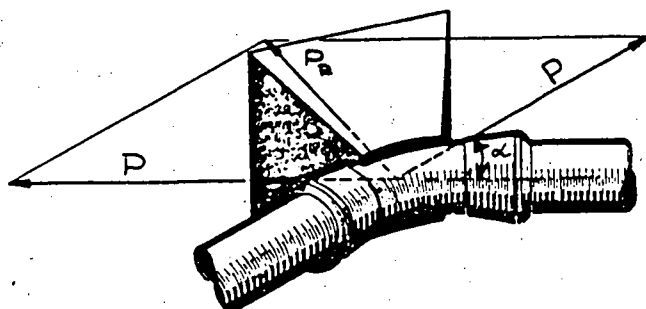

The following values of $2 \times \sin \frac{\alpha}{2}$ result for the most common angular deviations (bends):

11°	22°	30°	45°	60°	90°
0.2	0.4	0.5	0.8	1.0	1.4

Table 3: Dimensioning of thrust block, calculated for a test pressure of 15 bars and soil pressure of 0.1 N/mm²

	cm ² cm · cm	α = 11°	α = 22°	α = 30°	α = 45°	α = 90°	α = 60° PIPE END + BRANCHES
80	F B x H	500*) 20 x 25	500*) 20 x 25	600 23 x 26	850 29 x 30	1600 42 x 38	1150 34 x 33
100	F B x H	500*) 20 x 25	650 23 x 27	850 27 x 31	1250 35 x 36	2300 51 x 45	1650 41 x 40
125	F B x H	500*) 18 x 28	950 28 x 34	1250 34 x 37	1850 43 x 44	3450 62 x 55	2450 50 x 48
150	F B x H	650 21 x 31	1300 33 x 40	1750 40 x 44	2600 50 x 52	4800 73 x 65	3400 59 x 57
200	F B x H	1100 27 x 39	2250 43 x 52	3000 52 x 58	4450 66 x 67	8150 96 x 85	5800 78 x 75
250	F B x H	1600 34 x 48	3400 53 x 64	4550 64 x 71	6750 81 x 83	12400 118 x 105	8850 96 x 92
300	F B x H	2300 40 x 58	4800 63 x 76	6450 76 x 85	9600 97 x 99	17600 141 x 125	12500 114 x 110
400	F B x H	4000 52 x 76	8350 83 x 100	11150 100 x 112	16600 127 x 130	30450 185 x 165	21650 150 x 145

Absorption of shearing forces through ground friction

If it is not possible to transfer the shearing forces to the undisturbed ground of a trench side, recourse must be had to the force of resistance resulting from the ground friction.

This is calculated with the aid of the formula: $G \frac{P}{\mu}$

where

G = weight of the concrete body in N

P = shearing force - resultant

μ = frictional coefficient of average ground

Examples and recommended methods of construction are given in Module 3.6.

5 Pressure test

The separate components of a water main must be connected in such a way that no unwanted shifts of position can occur and the completed pipeline is watertight. Any changes of position after the pipes have been laid can seriously disrupt the system and usually lead to bursts. Leaks - which most often occur at joints - tend to gradually enlarge the weak spot and eventually cause considerable damage. Such effects can be avoided if the strength and water-tightness of all mains are tested after laying.

Before pressure is exerted, it is important to ascertain whether the main is adequately supported: In particular, thrust blocks must have been provided at bends and pipe ends and the mains must be loaded with earth bridges.

The correct procedure is to fill the pipe with clean water slowly enough to allow all the air inside it to escape. Trapped cushions of air cause percussions and thus may result in considerable damage.

The selected test pressure should be realistically, but not unnecessarily high. For long-distance transmission mains the test pressure should be 5 bars above operating pressure, but not less than 10 bars.

In service mains, the test pressure should be 1.5 times the nominal pressure.

Since temperature may affect the results of the test, a time should be chosen when temperatures can be expected to remain fairly constant. The temperature at the beginning and at the end of the test should be roughly the same.

The duration of the test depends on the diameter and on the length of the pipe section to be tested.

The following rough guide is given for water mains which are longer than 50 m:

up to DN 400	6 hours
between DN 400 and DN 500	12 hours
more than DN 700	24 hours

The test is considered to be passed if the pressure does not noticeably drop throughout its duration.

6 Flushing and sterilization

All water-supply systems must be cleaned, flushed and sterilized before going into operation.

In flushing, a volume of water several times the capacity of the pipe is forced through it at high speed, so that any contaminants, such as grit, stones etc. are carried away.

After flushing, the pipes are disinfected with chlorine. The chlorine concentration in the water should be between 5 and 10 g/m³. The pipe must always be completely full. The disinfectant solution is left in the pipe for several hours and then rinsed out. When rinsing out, care should be taken to avoid polluting the environment; the concentration of chlorine in the water should not then be greater than 0.5 g/m³.



Deutsche Gesellschaft für Technische Zusammenarbeit (GTZ) GmbH

Dag-Hammarskjöld-Weg 1 + 2 · D 6236 Eschborn 1 · Telefon (0 6196) 79-0 · Telex 407 501-0 gtz d

The government-owned GTZ operates in the field of Technical Cooperation. Some 4,500 German experts are working together with partners from some 100 countries in Africa, Asia and Latin America in projects covering practically every sector of agriculture, forestry, economic development, social services and institutional and physical infrastructure.

- The GTZ is commissioned to do this work by the Government of the Federal Republic of Germany and by other national and international organizations.

GTZ activities encompass:

- appraisal, technical planning, control and supervision of technical cooperation projects commissioned by the Government of the Federal Republic of Germany or by other authorities
- advisory services to other agencies implementing development projects
- the recruitment, selection, briefing and assignment of expert personnel and assuring their welfare and technical backstopping during their period of assignment
- provision of materials and equipment for projects, planning work, selection, purchasing and shipment to the developing countries
- management of all financial obligations to the partnercountry.

The series "**Sonderpublikationen der GTZ**" includes more than 190 publications. A list detailing the subjects covered can be obtained from the GTZ-Unit 02: Press and Public Relations, or from the TZ-Verlagsgesellschaft mbH, Postfach 36, D 6101 Roßdorf 1, Federal Republic of Germany.

TRAINING MODULES FOR WATERWORKS PERSONNEL

List of training modules:

Basic Knowledge

- 0.1 Basic arid applied arithmetic
- 0.2 Basic concepts of physics
- 0.3 Basic concepts of water chemistry
- 0.4 Basic principles of water transport
- 1.1 The function and technical composition of a watersupply system
- 1.2 Organisation and administration of waterworks

Special Knowledge

- 2.1 Engineering, building and auxiliary materials
- 2.2 Hygienic standards of drinking water
- 2.3a Maintenance and repair of diesel engines and petrol engines
- 2.3b Maintenance and repair of electric motors
- 2.3c Maintenance and repair of simple driven systems
- 2.3d Design, functioning, operation, maintenance and repair of power transmission mechanisms
- 2.3e Maintenance and repair of pumps
- 2.3f Maintenance and repair of blowers and compressors
- 2.3g Design, functioning, operation, maintenance and repair of pipe fittings
- 2.3h Design, functioning, operation, maintenance and repair of hoisting gear
- 2.3i Maintenance and repair of electrical motor controls and protective equipment
- 2.4 Process control and instrumentation
- 2.5 Principal components of water-treatment systems (definition and description)
- 2.6 Pipe laying procedures and testing of water mains
- 2.7 General operation of water main systems
- 2.8 Construction of water supply units
- 2.9 Maintenance of water supply units Principles and general procedures
- 2.10 Industrial safety and accident prevention
- 2.11 Simple surveying and technical drawing

Special Skills

- 3.1 Basic skills in workshop technology
- 3.2 Performance of simple water analysis
- 3.3a Design and working principles of diesel engines and petrol engines
- 3.3b Design and working principles of electric motors
- 3.3c —
- 3.3d Design and working principle of power transmission mechanisms
- 3.3e Installation, operation, maintenance and repair of pumps
- 3.3f Handling, maintenance and repair of blowers and compressors
- 3.3g Handling, maintenance and repair of pipe fittings
- 3.3h Handling, maintenance and repair of hoisting gear
- 3.3i Servicing and maintaining electrical equipment
- 3.4 Servicing and maintaining process controls and instrumentation
- 3.5 Water-treatment systems: construction and operation of principal components: Part I - Part II
- 3.6 Pipe-laying procedures and testing of water mains
- 3.7 Inspection, maintenance and repair of water mains
- 3.8a Construction in concrete and masonry
- 3.8b Installation of appurtenances
- 3.9 Maintenance of water supply units Inspection and action guide
- 3.10 —
- 3.11 Simple surveying and drawing work



Deutsche Gesellschaft für
Technische Zusammenarbeit
(GTZ) GmbH

P. O. Box 5180
Dag-Hammarskjöld-Weg 1+ 2
D 6236 Eschborn/Ts 1
Telephone (0 6196) 79-0
Telex 407 501-0 gtz d
Fax-No. -(0 6196) 79-1115