

A simple

# Guide

for  
the construction of  
affordable  
and  
environmentally  
Sanitary Latrine

REAL



Plan  
Be a part of it.

321.4-065I-19319

## Acknowledgement

---

Concept, Script and Technical Support

**Mr. Arumugam Kalimuthu**

Technical Advisor - Water Supply & Environmental Sanitation  
Plan International (India), New Delhi

Edited by

**Ms. Verity Corbett**

Programme Support Manager  
Plan International (India), New Delhi

Pictures Drawn

**Children in the Tsunami affected area**

C. Ashok Kumar (16), V. Selvavizhi (16)  
Manivannan (14), V. Jeyaveni (15)  
Nagapattinam District, Tamilnadu, India.

Design and development

**Mr. L. Peter**

Executive Secretary,  
Rural Education and Action for Liberation (REAL)  
Dindigul, Tamilnadu.

Facilitation artist

**Mr. A.J. Kennedy**

Drawing Master,  
Dindigul, Tamilnadu.

Printer

**Tacto Graphics**

Dindigul, Tamilnadu.

First Edition

August 2006

No part of this book may be reproduced in any form  
without the written permission of Plan International (India)

## Content

---

Site Selection	5
Fixing the right dimensions	7
Fixing the layout & earth work	9
Construction of basement & lining of leach pit	10
Selection of Pan	13
Placing Pan, P-trap (water seal) and stoneware pipe	14
Sealing of joints	15
Floor finishing	18
Superstructure construction	19
How to use your toilet	20
Materials required	23

Do you  
want to construct  
an affordable &  
cost effective latrine  
in your house?

If your answer is

“Yes”

read on!

**Is your house situated in a dry/semi arid climate region with no problem of water logging/shallow water table\* (ground water table is not shallow i.e. less than 10ft)?**

**If your answer is "Yes"**

**A leach pit toilet would  
serve your needs ...**

**The procedure for construction of single  
leach pit pour flush toilet is very simple ...  
just follow the steps  
narrated in the booklet ...**

**\*Village/Area prone to water logging/shallow water table is usually situated in coastal belt, perennial riverbanks and valleys. In the project site, if the water level in a bore well/open well is less than 10 ft, it can be considered as water logging/shallow water table area. In such location, avoid leach pit toilet construction and promote EcoSan.**

Let us understand various parts  
(components) of a  
single leach pit pour flush toilet

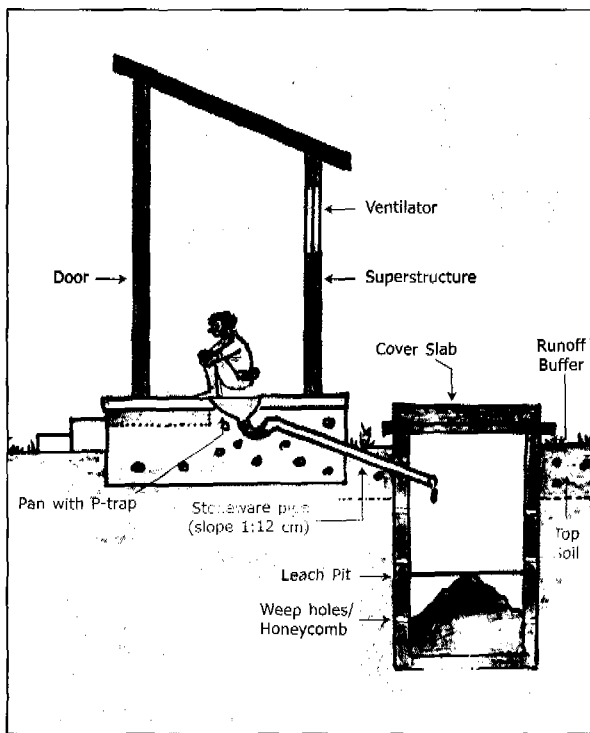

# Step 1

## Site Selection

**Proximity:** As far as possible, the toilet should be located very near the house/residence for convenience. As shown in the figure, using an existing wall of your house would reduce construction cost.

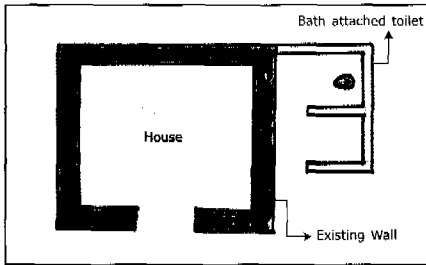

**Site condition:**

Avoid construction of leach pits in low-lying areas to prevent runoff water entering the leach pit.

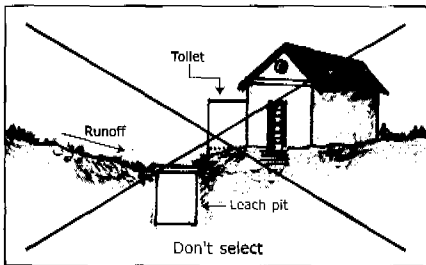

Permissible safe distance:

Maintain a safe distance between leach pit and drinking water sources.

Though safe distance between a leach pit and drinking water (ground water) sources varies from soil to soil, as a rule of thumb...

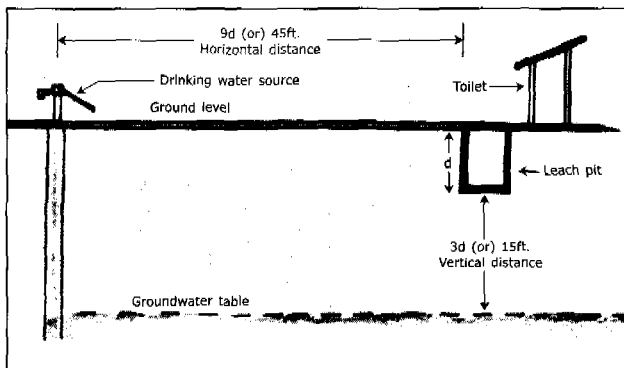

Horizontal distance between the leach pit and water source can be 9 times the depth of leach pit (or approximately 40 feet).

Vertical distance between the leach pit bottom and ground water table should be 3 times the depth of leach pit (or approximately 15 ft).



# Step 2

## Fixing the right dimensions

Depending on space availability around your house and what you can afford, decide whether to construct just a toilet or bath with attached toilet for the sake of convenience.

Suggested size for only a toilet:

Leach pit inner diameter: 3ft. and height: over 6ft.

Basement inner size: 3'6" x 3'6" (refer design)

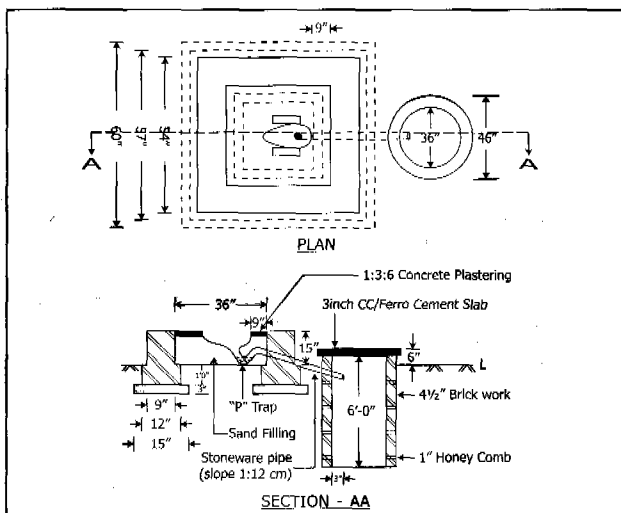

Leach pit inner diameter: 3ft.; Leach pit height: over 6ft.; Basement  
size: 7ft x 4ft (refer design).

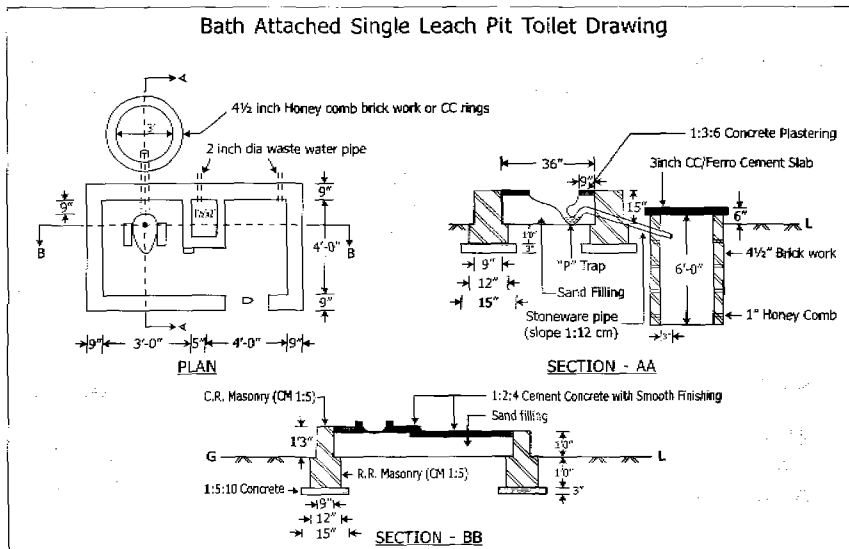

# Step 3

## Fixing the layout & earth work

Using lime powder, mark the layout on the ground before earthwork.

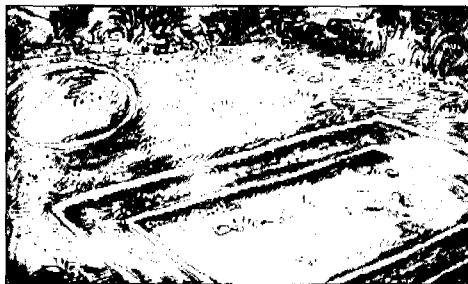

After marking, excavate the soil for the basement foundation and leach pit. 1-1½ft. deep pit is sufficient for basement foundation. The leach pit depth can be over 6ft.



# Step 4

## Construction of basement & lining of leach pit

Use locally available construction materials for the basement and leach pit lining construction - mud or cement mortar can be used.

Materials normally used for basement construction are:

- Rough stone/boulders
- Brick/fly ash brick
- Hollow blocks/solid blocks



Materials that can be used for leach pit lining include:

- Rough stone/boulders
- Brick/fly ash brick
- Cement/ferrocement rings
- Bamboo mats etc.

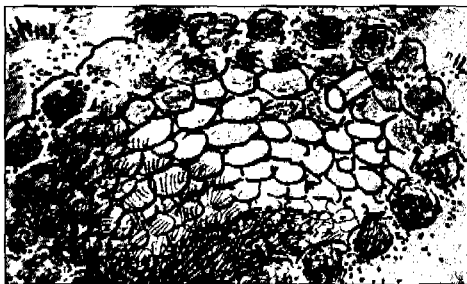

lining  
with  
boulders

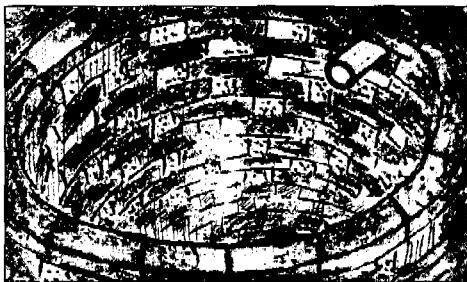

lining  
with  
bricks

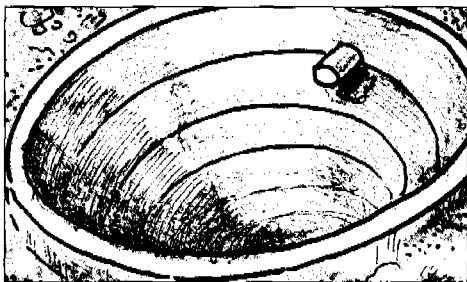

lining  
with  
cement  
rings

While constructing the leach pit, take care of the following:

- Weep holes or honeycomb arrangements in the lining of leach pits are to be made only below the topsoil level.
- The lining of the leach pit should be sealed completely by top soil if the formation is loose (max. up to 2 feet).
- Raise the lining 3-6 inches above ground level to prevent runoff entry into the leach pit.
- Soil/stoneware pipe from the P-trap should extend well inside leach pit (minimum of 3 inches projection)
- Leach pit should be covered with RCC or ferrocement slab and sealed thoroughly.
- Do not provide a vent pipe to the leach pit like septic tanks.

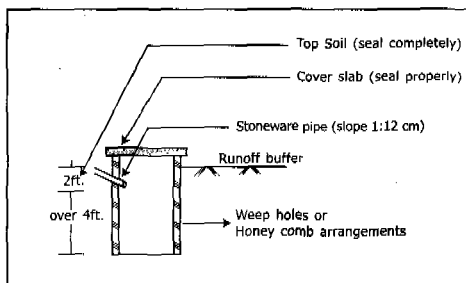

# Step 5

## Selection of Pan

There are two types of Indian water closets (pans) available in the market (footrest attached and without footrest attachment)

- Use a pan with the footrest attached to avoid construction faults wherever possible.
- For children toilets use small pans (20 inches size)
- For the convenience of physically challenged people use western type pans.

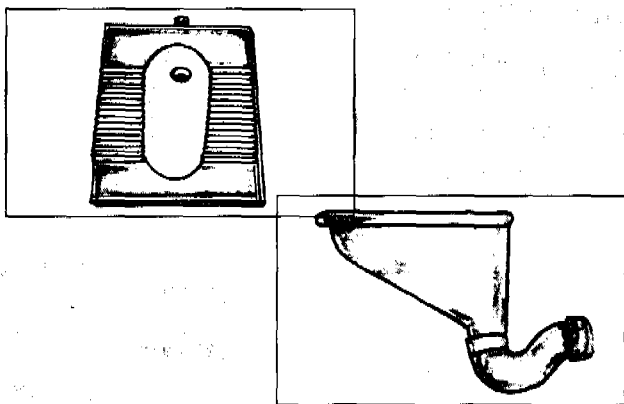

Various types of pans such as ceramic, mosaic, micro concrete and fibre/plastic are available in the market.

# Step 6

## Placing Pan, P-trap (water seal) and stoneware pipe

Assembling of pan, p-trap and stoneware pipe is an important part of toilet construction. Use a spirit level to carefully level the pan and fix the P-trap to it. Fix the pan in such a way that the back edge of the pan is located at a distance 9 inches from backside wall of the toilet.

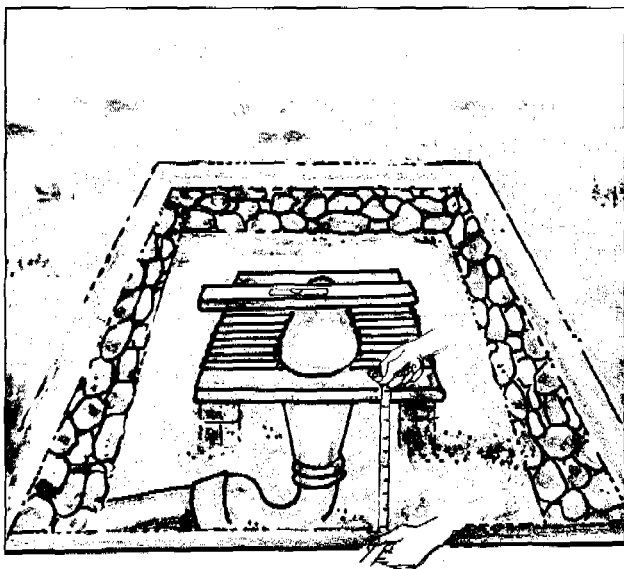



# Step 7

## Sealing of joints

The joints between the pan & p-trap and p-trap & stoneware pipe should be sealed properly to prevent any leakages. Wet cloths/gunny bags dipped in cement slurry can be used to seal these joints.

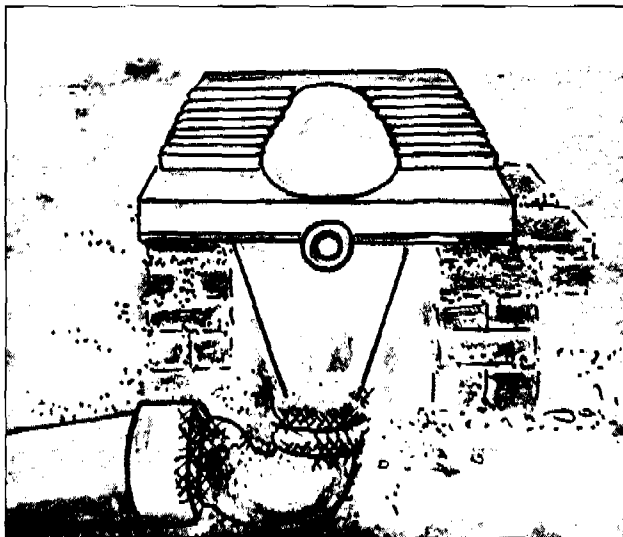

After fixing and sealing the joints, fill the basement with brick ballast and sand. Ensure tight packing around the pan assembly.

While fixing the basin, proper alignment is essential.  
Avoid following mistakes.

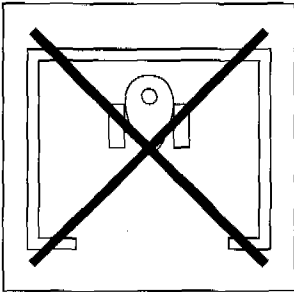

Very close to back wall

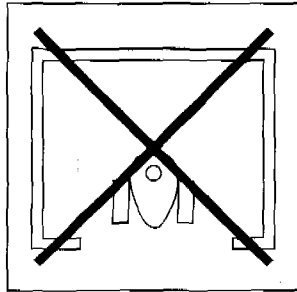

Very close to door

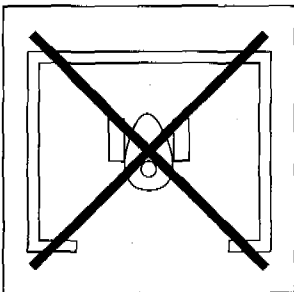

Reversal

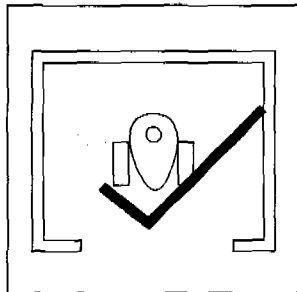

Right set-up

Similarly, if you are fixing the footrests yourself, avoid the following construction faults.

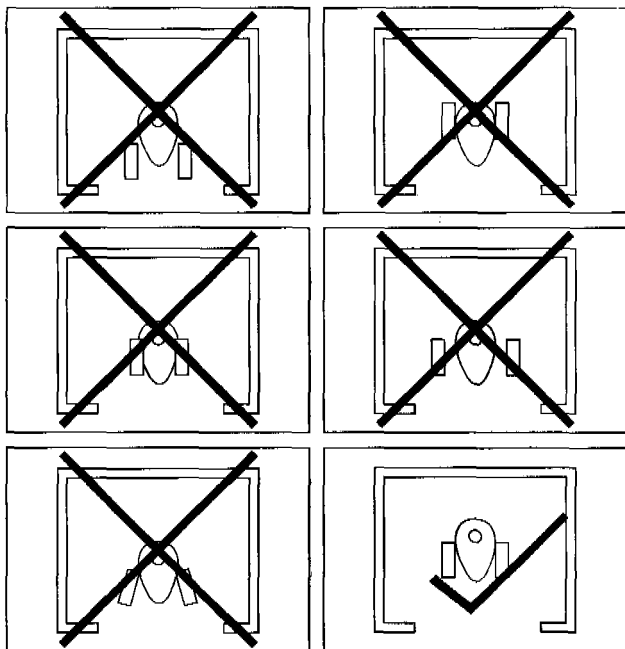

Fixing the footrest wrongly makes use uncomfortable.

# Step 8

## Floor finishing

Floor finishing can be done with good cement mortar. Provide proper slope towards the pan. Please note that the top edges of the toilet pan should be below floor level.

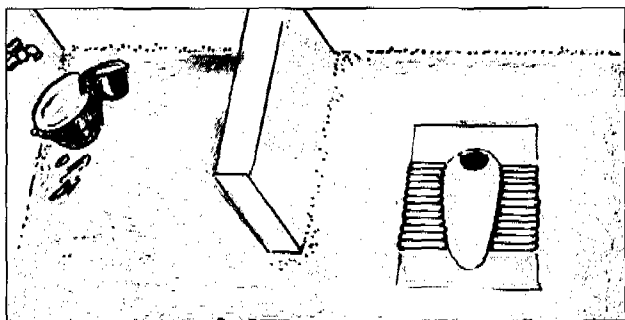

# Step 9

## Superstructure construction

Depending on what you can afford, select the right materials for the superstructure construction. Materials such as thatch, palm leaf, reeds, fertiliser/gunny bags, hollow blocks, solid blocks, bricks, ferrocement slab, etc., can all be used.



If your area receives normal rainfall and has no high raised buildings surrounding your toilet, roof cover for the toilet is not really necessary.

## How to use your toilet

Before use, pour a litre of water to wet the pan.

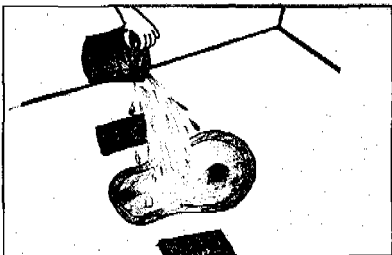

Position yourself properly over the pan.

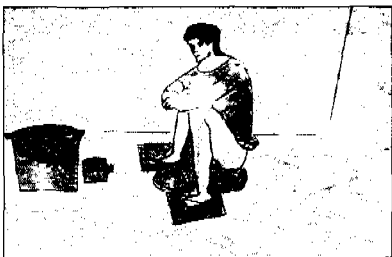

After defecation, flush the toilet. Ensure Faecal matter passes into the water seal.

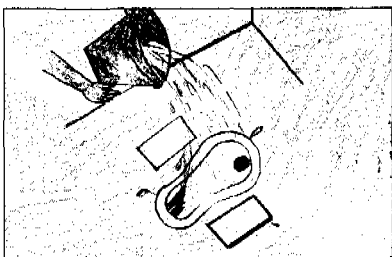



Wash your hands  
using soap, ash or  
mud.



Keep your toilet  
neat & clean



After use, keep the  
toilet door shut.

## Please note

Do not put a vent pipe on your leach pit. The vent pipe is only needed for septic tanks and not for leach pits.

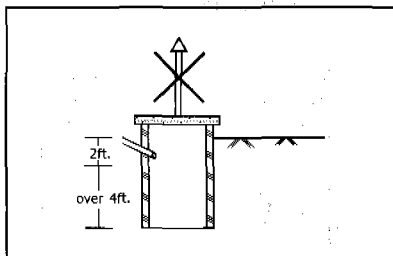

A deeper leach pit lasts longer than the shallow pit, it is advisable to go for a deeper pit (over 6 ft.)

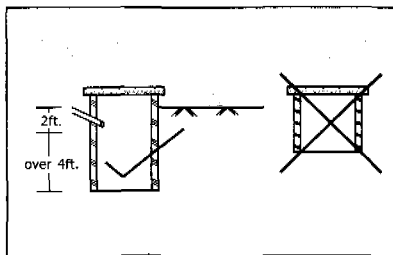

A leach pit model is not advisable for water logged or water scarcity areas. In such conditions, eco-san is a preferable design.

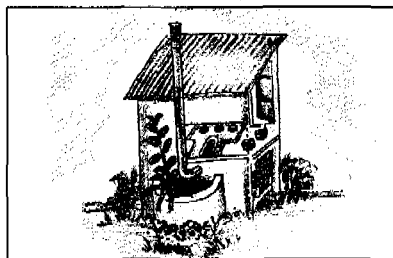



The construction materials required up to basement level for single toilet unit are:

Component	Materials Required
Leach pit	Using cement rings: 6 rings of 3 ft. diameter and 1 ft. height or Using honey comb brick construction: 225 bricks, 15kg cement and 0.7 cft. sand
Leach pit cover slab	6mm rod (steel) - 5kg, binding wire, cement 14kg, sand 0.7 cft and broken stone chips 1.41 cft.
Basement	550 bricks, cement 40 kg, 15 cft sand, 3.50cft brick ballest, 1 pan, 1 p-trap and 1 stoneware pipe.

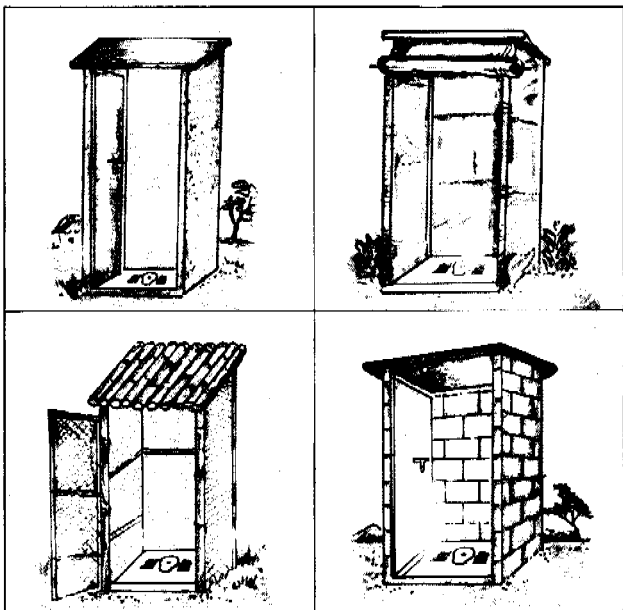

## Cost Estimate

Since materials cost varies from place to place, no cost details are incorporated in this booklet. Experience shows that a bath attached, thatched superstructure model costs around Rs.1,250/- and bath attached hollow block model costs around Rs.2,500/-



**Plan**

Be a part of it.

Supported by

**Plan International (India)**

B4/161, Gulmohar House, 5th Floor,  
Gautam Nagar, New Delhi - 110 049, India  
EPABX: +91 11 26962605, 26968432-34

Fax: +91 11 26863417

email: [India.co@plan-international.org](mailto:India.co@plan-international.org)

[www.plan-international.org](http://www.plan-international.org)

---



**20**  
YEARS  
IN PEOPLE'S DEVELOPMENT

Designed and developed by

**Rural Education and Action for Liberation (REAL)**

M-2/179, R.M. Colony, 12th Cross,  
Dindigul - 624 008, Tamilnadu, India.

Ph: +91 451 2432242 Fax: +91 451 2427799

email: [real@md4.vsnl.net.in](mailto:real@md4.vsnl.net.in)

[www.realsocialservice.com](http://www.realsocialservice.com)

For

**The Communities of Water & Sanitation**

Join WES-Net India, join the National Movement.

For registration, please visit: [www.wesnetindia.org](http://www.wesnetindia.org)



**WES-Net India**  
WATER AND ENVIRONMENTAL SANITATION

# Guide

