

321-4  
83VE

ISN 702

## Preface

Application of the Ventilated Improved Pit (VIP) latrines on massive scale in future sanitation programmes in Developing Countries is most likely. Therefore, a research on the ventilation aspects of this sanitation system was necessary.

The main conclusion of this report: "The VIP latrine, a ventilation study" is that, with regard to ventilation efficiency, the VIP latrine functions properly as long as there is wind blowing over the top of the vent-pipe.

Depending on the wind velocity, ventilation volumes ( $m^3/s$ ) can reach significant values.

Details on the ventilation pipe as diameter, length etc. can be found in Chapter 5, Conclusions.

Chapter 2 deals with theoretical background material, while the other chapters reveal information on the field research. The field research is executed at the Building Research Unit (BRU) in Dar es Salaam, Tanzania.

The literature study, evaluation and report-writing took place in Delft, The Netherlands.

~~KD-154~~

20

copy



## Acknowledgement

I would like to express my sincere gratitude to the following people for their contribution and cooperation in realizing this research, which is a part of my MSc study, Civil Engineering, division of sanitary engineering at Delft, University of Technology (DUT) The Netherlands.

Prof. dr.ing. H.J. Pöpel	Supervisor, Dept. of Civil Engineering, Division of sanitary engineering, DUT.
Ir. Dick C. van Ginhoven	Act. Head of department of Public Health Engineering, Ardhi-Inst. Dar es Salaam.
Mr. R.A. Boydell	Advisor to the LCSU Low Cost Sanitation Unit, Ardhi-Ministry, Dar es Salaam.
Mr. D. Baker	Gauff Ingenieure, Consulting Engineers Dar es Salaam.
Ir. H. van Oorschot	Dept. of Mathematics, DUT
Ir. R. Veldkamp	Sanitary Eng., dept of Civil Eng. DUT

Furthermore I would like to thank staff and students of the dept. of Public Health Engineering, Ardhi-Inst. DSM, for their hospitality and friendship.

Adress :  
Spoorsingel 61  
2613 BA DELFT  
The Netherlands

Peter Heeres  
Sept. 1981 - Aug. 1982  
tutorial assistant  
Dept. of PHE/Ardhi - Inst.  
Dar es Salaam / Tanzania



Contents		Page
Preface		i
Acknowledgement		ii
Contents		iii
List of figures		v
Tables		vii
Appendices		viii
Introduction.		1
Chapter 1.	Ventilation Studies	
1.1	Introduction	2
1.2	Goals of the research	4
1.3	Ventilation	6
1.3.1	Definition	6
1.3.2	Types of flows	8
1.3.3	Factors influencing ventilation	10
1.4	Standards	11
Chapter 2.	Theoretical Background	14
2.1	Introduction	14
2.2	Secondary flow	15
2.3	Windtunnel experiments on several types of chimney caps, influence of wind gradient.	16
2.4	Losses in flow	19
2.4.1	Pipes	19
2.4.2	mosquito gauze	21
2.4.3	Calculation example, head loss	22
2.5	Influence of temperature on ventilation	24
2.6	Conclusions	27
Chapter 3.	Field Study	28
3.1	Introduction	28
3.2	Wind condition in Dar es Salaam	28
3.3	Description of the installation	29
3.3.1	VIP latrine at BRU	29
3.3.2	Equipment	31
3.4	parameters selected	33
3.5	The test programme	37



Chapter 4.	Recording and evaluation of the results	
4.1	Recording of the results	38
4.2	Evaluation of the results	43
4.3	Analysis of variance	43
4.3.1	Ventilation velocity (m/s), diameter	43
4.3.2	Ventilation volume (m <sup>3</sup> /s), diameter	48
4.3.3	Quantification of influence of diameter on ventilation volume	52
4.4	Mosquito gauze	53
4.5	Cover	55
4.6	Position/length vent-pipe	56
4.7	Open/closed door	57
Chapter 5	Conclusions	58

## Appendices





## List of figures

1.1	A simple pit latrine in rural Kenya	3
1.2	Ventilated pit privy, as used in Zimbabwe	3
1.3	Frontside of VIP latrine	4
1.4	as Fig. 1.3	5
1.5	Cross section A-A, showing squatting slab	5
1.6	Ventilation openings in test latrine	6
1.7	Cross ventilation	8
1.8	Pit ventilation	9
1.9	Air supply rate for odour removal	11
2.1	Ground whirle	15
2.2	Eddies	15
2.3	Draught in a chimney	16
2.4	Installation in windtunnel	16
2.5	Chimney caps	17
2.6	Representation of table 2.1	18
2.7	Relationship between roughness, friction and Reynolds Number	20
2.8	Losses in flow, depending on diameter, ventilation velocity and mosquito gauze.	23
2.9	Theoretical ventilation velocity, depending on difference in temperature and shaft height.	25
2.10	Temperatures over 24 hours in a VIP latrine	26
3.1	Frontside VIP latrine, BRU, Dar es Salaam	29
3.2	Schematic drawing of VIP latrine, including North indication	30
3.3	Pitot-tube	31
3.4	Location pitot-tube	31
3.5	VIP latrine at BRU, including anemograph	32
3.6	View from frontside VIP	32
3.7	Possible location vent-pipe	33
3.8	Top of VIP latrine	34
3.9	Enlargers	35
3.10	Mosquito gauze on top vent-pipe	35



3.11	Cover	35
3.12	VIP latrine equiped with L-shaped wall	36
4.1	Chart 1, ventilation velocity	38
4.2	Chart 2, anemograph	38
4.3	Photocopy of charts	39
4.4	Wind-/ventilation velocity relation	40
4.5	Calculation of variance stabilizing coefficient	45
4.6	Diameter/area of cross-section	48
4.7	Influence of cover on ventilation	55
4.8	Influence of position/length vent-pipe	56
5.1	Wind/ventilation velocity relation	58



## List of tables

1.1	Ventilation openings in test latrine	7
1.2	Coefficient of pressure at the surface	9
1.3	Minimum ventilation velocities	13
2.1	Average value of $\Delta p/P_s$ , for three different wind velocities with changing wind gradient	18
2.2	Head loss calculations	22
2.3	Some properties of air	24
2.4	Temperatures over 24 hours in VIP latrine	26
3.1	Information on vent-pipes used	33
3.2	Relation between length, height roof/top vent-pipe and location of vent-pipe	34
3.3	Survey test programme	37
4.1	Results of the least square method ( $Y = b \cdot x + a$ )	41
4.2	Measurements	42
4.3	Code of measurements diameter/position	43
4.4	Standard deviations linear regression calculations, wind speed $2.5 \leq (m/s)$ and $w_s > 2.5 (m/s)$	44
4.5	Variance stabilizing transformation	46
4.6	Values of transformed average ventilation velocities	47
4.7	Analysis of variance table, transformed values of average wind velocity.	48
4.8	Variance stabilizing transformation, ventilation volume	49
4.9	Analysis of variance transformed values of ventilation volume	50
4.10	Analysis of variance table, transformed average values of ventilation volume	51
4.11	Results diameter	52
4.12	Mosquito gauze significance testing	54
4.13	Results mosquito gauze	54
4.14	Results cover	55



## List of appendices

- 1 Results of least square method and statistical information for each measurement seperately.
- 2 List of references
- 3 Day-programme and weather conditions
- 4 List of equipment
- 5 Distribution of t (two tailed tests)





## Introduction

The ministry of Lands, Housing and Urban Development of the United Republic of Tanzania in cooperation with Gauff Ingenieure, consulting engineers/Dar es Salaam, is working on the Buguruni squatter upgrading programme. The Buguruni area is in Ilala District within Dar es Salaam region, Tanzania.

A component of the Buguruni project is the construction of VIP (Ventilated Improved Pit) latrines.

Experience from other VIP latrines in Dar es Salaam indicated that VIP latrines ventilate reasonably.

In order to find the magnitude of this ventilation and the influence of some parameters, this ventilation research was set up. The effect of for example wind speed on ventilation of a VIP latrine is not predictable, due to too many different aspects (wind direction, slope of the roof, environment, etc.), a field study was therefore necessary.

The field study is executed at the BRU (Building Research Unit) in Dar es Salaam, where for this purpose an experimental VIP latrine was built.

This report deals with the measurements on this VIP latrine at the BRU.

A literature study has been undertaken, in Delft/The Netherlands, to support the field measurement.

The over-all conclusions can be found in chapter 5.



The Ventilated Improved Pit-latrine (abbreviated by VIP) is a serious option as a low-cost sanitation method. This simple excreta disposal system differs from conventional pit latrines in the way it's constructed.

A conventional pit latrine is sometimes not more than a dug pit or an oil-drum in the ground, covered f.i. with planks to facilitate squatting. The fence can be made of wooden poles with in between palm- or bananaleaves or gunny sacks.

The VIP latrine differs from the conventional pit latrine by having a vent-pipe, a more solid way to construct the pit, squatting slab and superstructure.

The most striking detail of the VIP latrine is the vent-pipe, wick generates a strong updraft and so maintains a flow of air down through the squatting plate. The effect of this air current is to minimize odours and to discourage fly breeding within the pit; moreover, if the exit of the vent-pipe is covered with a mesh and the latrine superstructure is kept relatively dark compared to the pit ( or the squat plate covered) any flies wick do hatch out in the pit will be attracted to the daylight at the top of the vent-pipe, where they will be trapped by the mesh and eventually die.

The VIP latrine technology is identified by the World Bank on technical, social and financial grounds as a realistic option for sanitation.

Several types of ventilated improved pit latrines have been developed. In the series of the World Bank of 'Appropriate Technology for Water Supply and Sanitation' some types of VIP latrines are described.





Fig. 1.1 A simple pit latrine in rural Kenya. A latrine of this sort may be quite acceptable for many years but tends to become smelly and to attract flies. It may be improved by adding ventilation. (Photo R. G. Feachem)

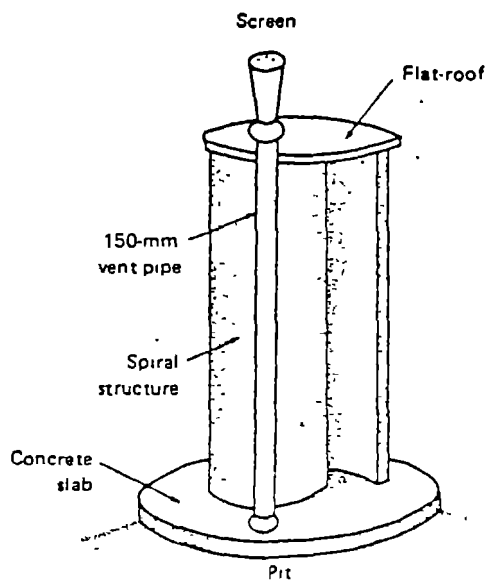

Fig. 1.2 ventilated pit privy, as used in Zimbabwe



## 1.2      Goals of the research

Pilot projects, as there was the Dar es Salaam demonstration project, revealed that the majority of the VIP latrines do ventilate satisfactorily.

The questions put forward in this research are:

- What is the magnitude of the ventilation ?
- What kind of factors have an influence on ventilation ?
- How much influence has each factor on ventilation ?

The results of this research should give design guidelines for a VIP latrine reference to ventilation.

Fig. 1.3    Frontside of the VIP latrine built at the Building Research Unit in Dar es Salaam, Tanzania.

Most of the VIP latrines in Dar es Salaam are elevated, due to the high ground-water table.

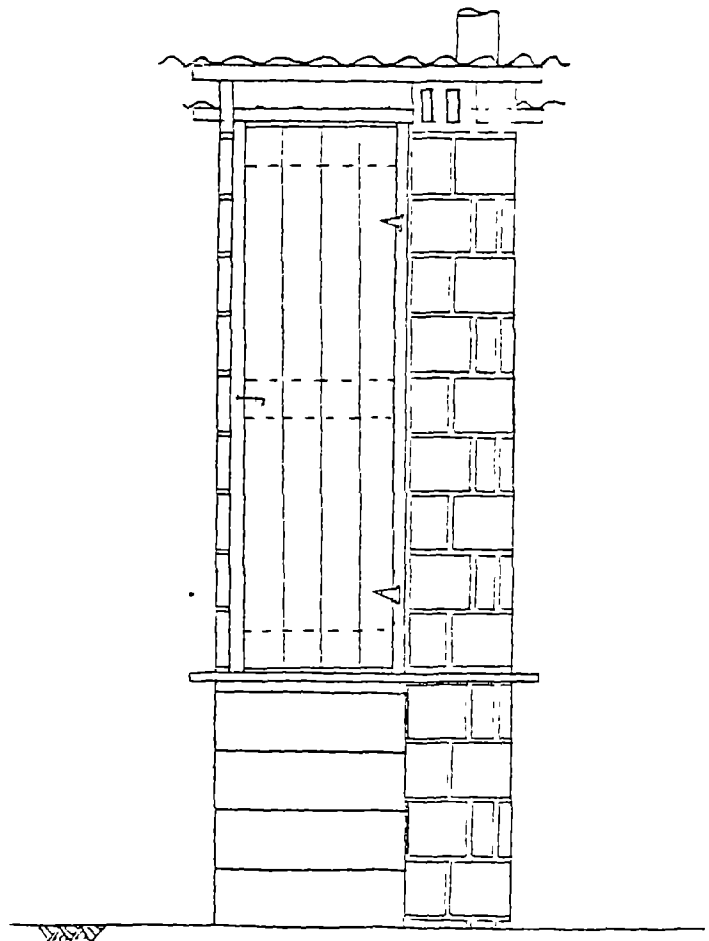





5

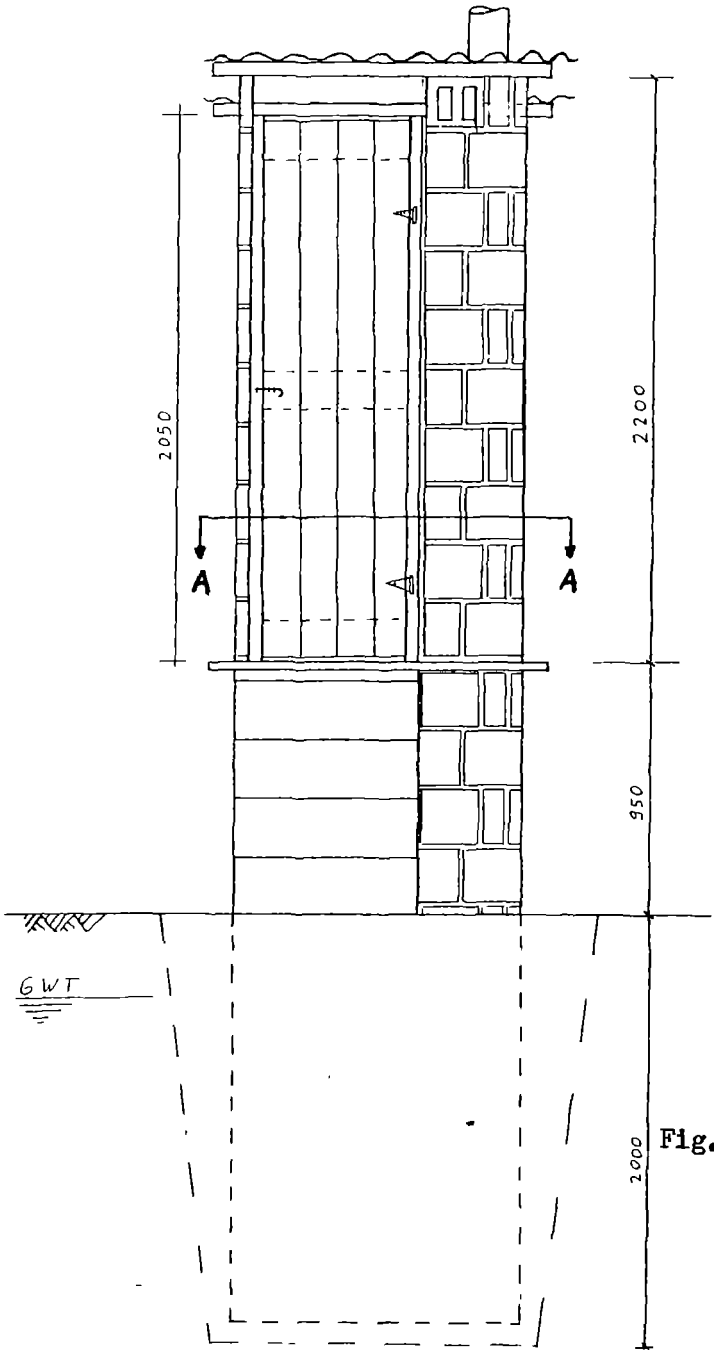
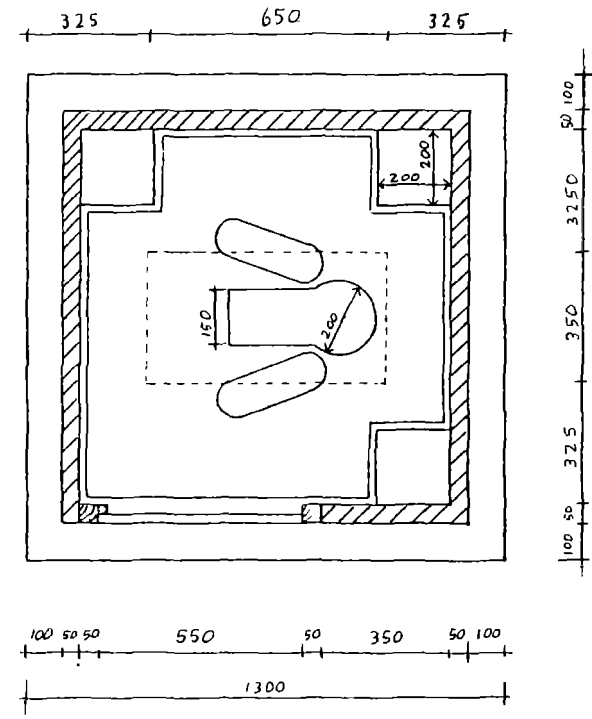

Fig. 1.4 Frontside of VIP latrine



/// Sand/cement wall

Fig. 1.5 Cross-section A-A, showing squatting slab







Openings, important to ventilation. ( VIP latrine, BRU )

A	Front side, above door	1100 cm <sup>2</sup>
B	Two small openings	80 cm <sup>2</sup>
C	Side walls (each)	160 cm <sup>2</sup>
D	Back side	440 cm <sup>2</sup>
E	Key hole	655 cm <sup>2</sup>
F	Ventilation pipe	diameter 10,15, 20 cm

Table 1.1 Ventilation openings on test latrine.



### 1.3.2 Types of flows

Two ventilation flows can be defined :

- a. Cross-ventilation: By cross ventilation I mean, a flow of air entering and leaving the superstructure through ventilation openings in the walls of the superstructure. The magnitude of this ventilation flow is not measured at the test latrine.

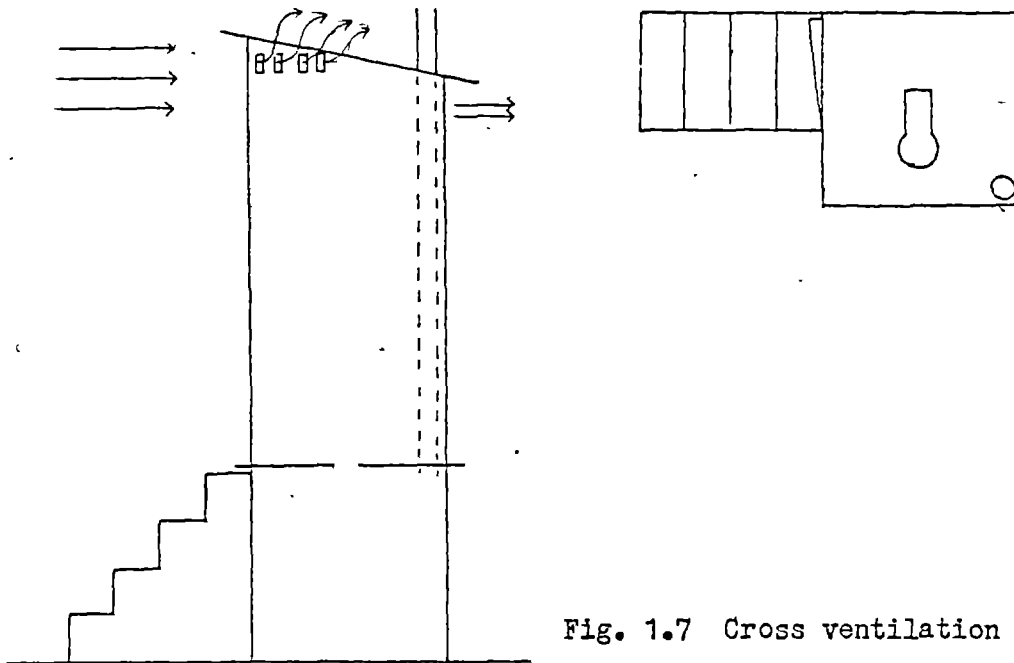

Fig. 1.7 Cross ventilation

This type of ventilation depends on :

- a - wind ( velocity, direction)
- b - design superstructure (position and flow characteristics of all openings, construction superstructure)





British Standards gives for a construction as the VIP latrine for the distribution of pressure at the surface. ( $C_p$ )

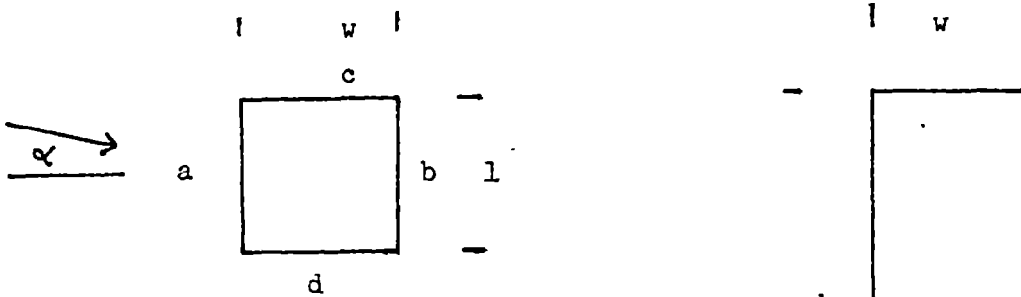

Height ratio  $\frac{h}{v} = \frac{3.2}{1.1} = 2.9$

Plan ratio  $\frac{l}{w} = 1$

$\alpha$	Cp for surface			
	A	B	C	D
0	0.8	0.25	0.8	0.8
90	0.8	0.8	0.8	0.25

Table 1.2 Coefficient of pressure at the surface

Ventilation volume:  $Q_w (\frac{m^3}{s}) = C \times (C_p)^{\frac{1}{2}}$

C depends on wind velocity/ventilation openings.

b: Pit-ventilation: Pit ventilation occurs when a flow of air is entering the pit through the key-hole, passes through the pit and leaves the pit through the vent-pipe. Wind blowing over the top of the vent-pipe creates an underpressure by wich ventilation is induced. A chimney works according the same principle.

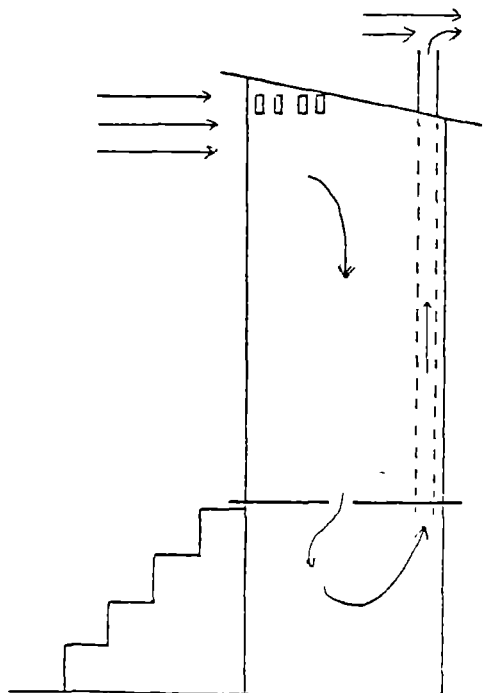

Fig. 1.8

Pit ventilation



### 1.3.3 Factors influencing ventilation

Factors which might influence the ventilation to more or less extent are listed here under.

1. wind velocity
2. wind direction
3. angle of the wind, compared to horizontal, in relation to the top of the vent-pipe
4. diameter vent-pipe
5. diameter top vent-pipe
6. length vent-pipe
7. height top vent-pipe to roof
8. location of the vent-pipe inside the latrine
9. mosquito gauze on top of the vent-pipe
10. a cover on the squatting plate
11. ventilation/light openings in the superstructure
12. weather conditions, other than wind
13. surface roughness of the vent-pipe
14. location of the latrine in relation to the surroundings
15. design superstructure

Not all factors are discussed in detail in this report. Only with the direct results of the measurements will be dealt here.

The advantage of the experimental VIP latrine at the BRU was that some parameters could be monitored.

The following parameters :-diameter vent-pipe

- height vent-pipe above the roof/  
length vent-pipe
- the use of enlargers/diameter top vent-pipe
- location of the vent-pipe inside the latrine
- mosquito gauze
- cover
- door open/closed

Later on in this report, the influence of above mentioned parameters on wind velocity/ventilation velocity relation will be discussed.



## 1.4 Standards

In order to get an idea of how much ventilation, calculated as ( $\text{m}^3/\text{h}$ ) of fresh air flowing through the vent-pipe, is required some standards from several countries are put together.

The Netherlands	(1)	NEN 1087
United Kingdom	(2)	BS 5925
India	(3)	IS 3362
Australia	(4)	AS 1668
(IHVE Guide)	(5)	

### 1. The Netherlands

living room	0.021 - 0.042	$\text{m}^3/\text{s}$ (75 - 150 $\text{m}^3/\text{h}$ )
other rooms	0.001	$\text{m}^3/\text{s}$ per $\text{m}^2$ floorarea with a minimum of
	0.007	$\text{m}^3/\text{s}$ (3.6 $\text{m}^3/\text{h}$ per $\text{m}^2$ floor area)
bathroom	0.014	$\text{m}^3/\text{s}$ (50 $\text{m}^3/\text{h}$ )
Water Closet	0.007	$\text{m}^3/\text{s}$ (25 $\text{m}^3/\text{h}$ )

### 2. United Kingdom

See fig. 1.9 Air supply rate for odour removal.

This figure gives as required ventilation for a room with a volume of  $3.3 \text{ m}^3$  the number of 11.1 litres/second ( $40 \text{ m}^3/\text{h}$ )

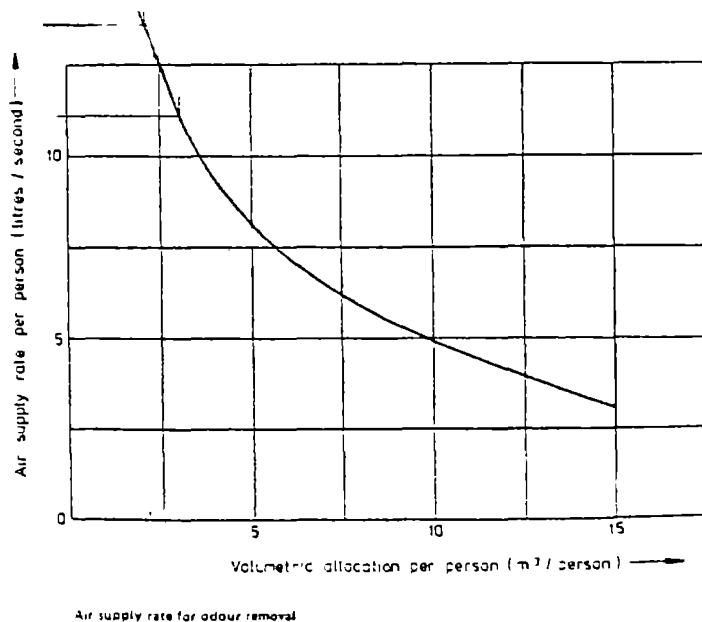

Fig. 1.9



### 3. India

Living room and bed room	Three changes per hour should be provided
Bathroom and W.C.	Three air changes per hour should be provided

### 4. Australia

General living area, bedrooms	Minimum fresh air requirement per person	2.5 L/s
Kitchen	10	L/s
Bath, Toilet room	10	L/s

### 5. IHVE Guide

Table B 2.2 Mechanical ventilation rates for various types of buildings, lavatories and toilets, internal 6-8 recommended air change rates (  $h^{-1}$  )

The standard for latrines are based on, a: inside toilet  
b: water-closet

The Dutch and Indian standards do mention that the standard for a W.C. is based on the idea that considerable ventilation after use is desirable.

With a pit latrine we should not only consider that there will be an unpleasant odour after use, but secondly also of a smell from inside the pit which might enter the superstructure through the key-hole. To get rid of this nuisance a large but especially continuous flow of air through the vent-pipe is preferable.

#### Calculation example

A VIP latrine	floor area	1 m <sup>2</sup>
	height	2.1 m
	volume VIP	2.1 m <sup>3</sup>

Standards in m<sup>3</sup>/h

1	25 m <sup>3</sup> /h
2 figure gives 12.24 L/s	44
3 three times 2.1	6.3
4 10 Litres per second	36
5 eight times 2.1	16.8



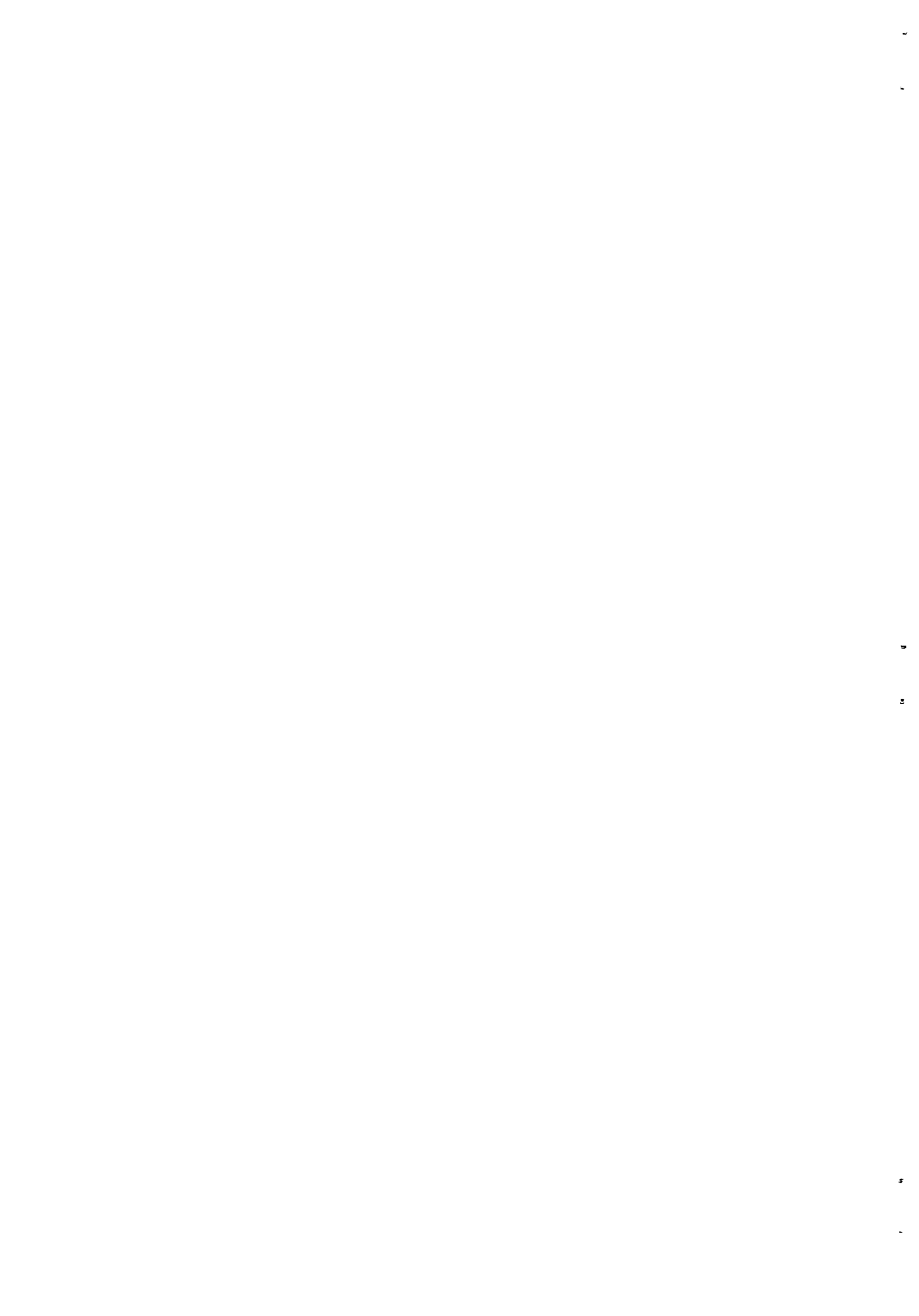

When we transfer the standards to the minimum required ventilation velocities for different vent-pipes, than we get the following values.

Diameter (inch)	4	6	8
( cm )	10.16	15.24	20.32
Area cross-section (cm <sup>2</sup> )	81.07	182.41	324.29
Standard m.			
1	25 m <sup>3</sup> /h	0.86 m/s	0.38
2	44 "	1.51	0.67
3	6.3 "	0.22	0.10
4	36 "	1.23	0.55
5	16.8 "	0.58	0.26

Table: 1.3 Minimum ventilation velocities, according different standards for a 4", 6" and 8" vent-pipe.



## Chapter 2      Theoretical background

### 2.1 Introduction

The principal of natural ventilation is old. However information on the type of ventilation, mentioned in chapter 1.2.3 as pit ventilation, typically for VIP latrines is hard to find. The literature referred to in this chapter originates from 1932 to 1958.

Subjects dealt with in this chapter are :

- the principle of creating draught in a pipe by wind.
- Influence of wind velocity and -gradient on draught in a pipe.
- losses in flow due to friction and mosquito gauze.
- The last sub-chapter deals with the influence of sun radiation on ventilation on a type of VIP latrine, as built at the BRU. A 24 hour measurement of temperatures in and outside the latrine is used as basis for this chapter.

Unfortunately no information is found on the influence of pipe diameter on draught.

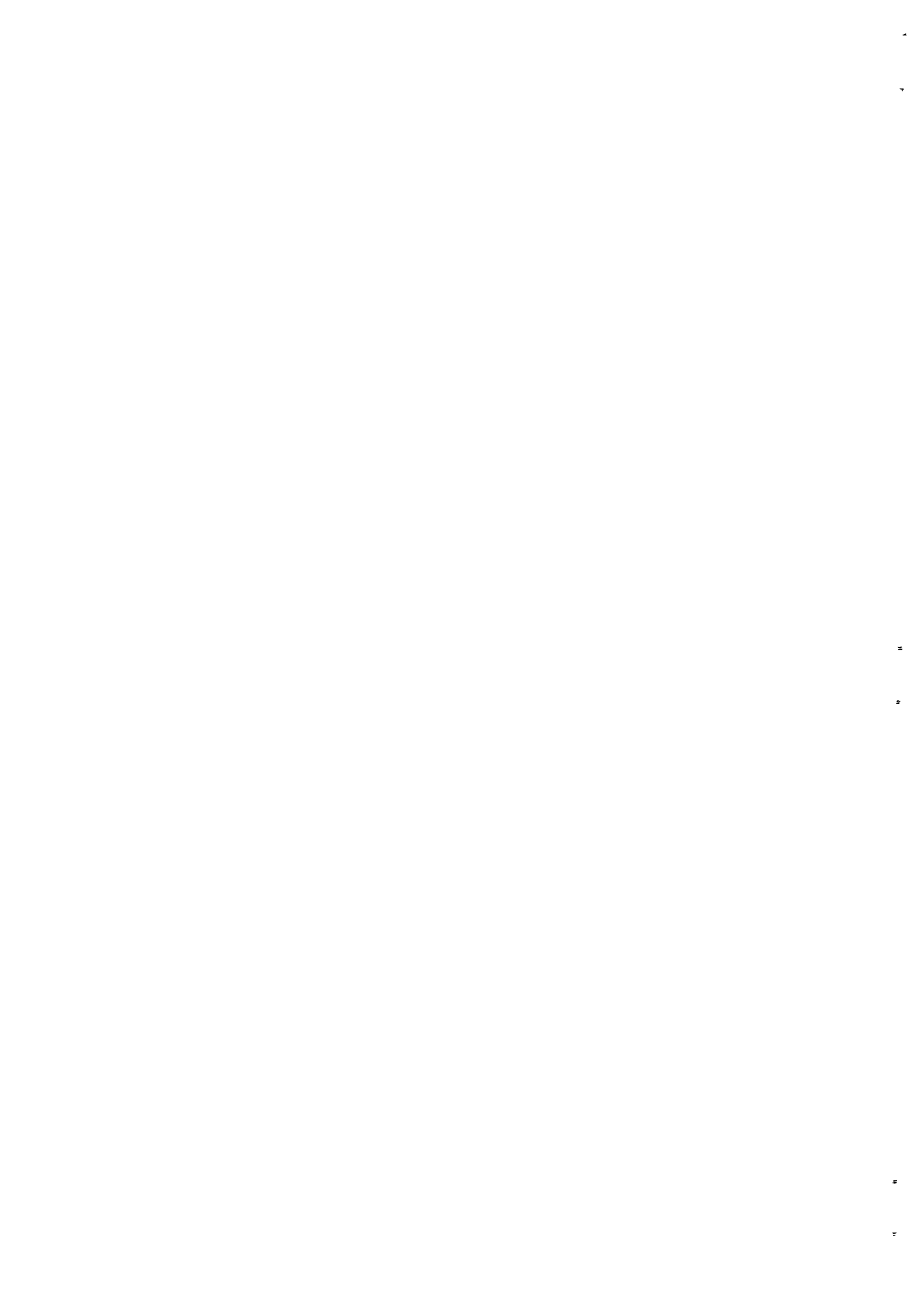

## 2.2 Secondary flow

Secondary flow is flow induced by a main flow. Examples of secondary flow are shown in fig. 2.1 and fig. 2.2.

The main flow (horizontal) approaching the pipe over the full length induces two types of secondary flows.

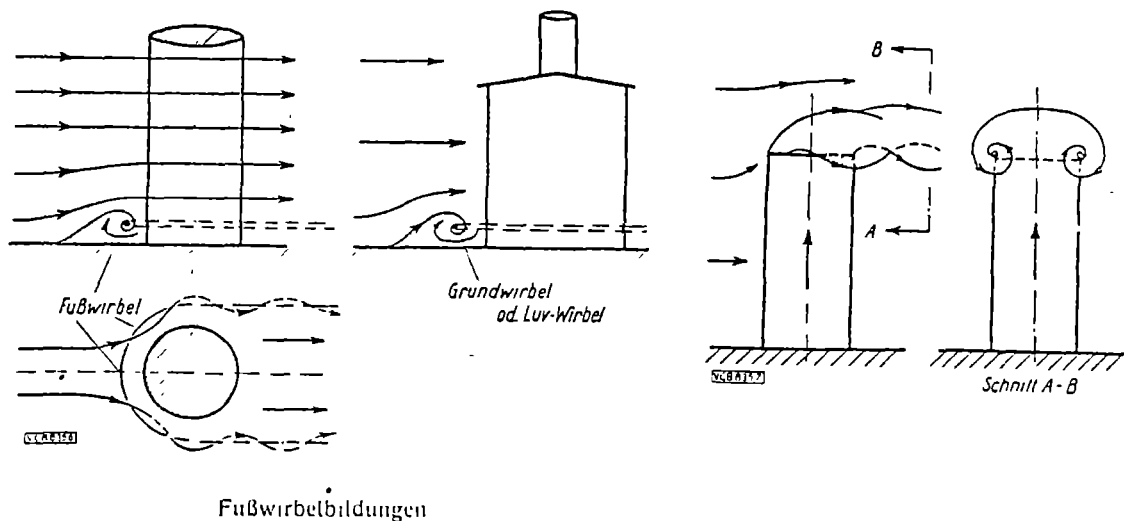

Fig. 2.2 eddies, on top-pipe.

Fig. 2.1 Ground-whirle.

I A ground-whirle near the basis, fig.2.1, is created because the main flow encounters near the ground some resistance. This whirle plits up in two ways around the obstacle, one to the left and one to the right. These two whirles will continue in the direction of the flow as two small spiral-like whirles. You can notice a ground-whirle as a draught near/in front of big buildings or mountains. Ref. 18 mentions this mechanism in reference to roofs of high buildings, especially on wich chimneys are located.

II At the free end (top) of the pipe, two eddies (fig. 2.2) are induced by the main flow, wind. At the same time a strong draught and flow (vertically) is created in the pipe by this effect.



Pressure- and velocity measurements, in a research by H.Föttinger, show a relation between the statical underpressure  $\Delta p$  in a chimney divided by the wind-pressure and the flow velocity in the pipe divided by wind velocity.

This relation, fig. 2.3, shows that the underpressure drops, initially quickly and later on slowly, to zero with increasing flow velocity when the in- and outside velocities equalize. Characteristics of the chimney are unfortunately not mentioned in this report ( ref. 19).

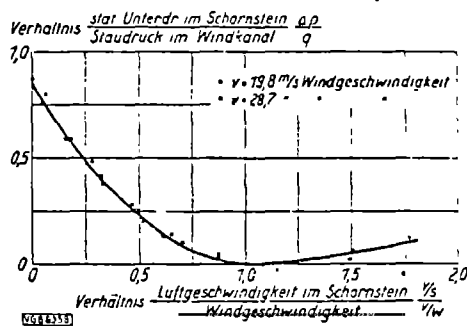

Fig. 2.3 Draught in a chimney

2.3 Windtunnel experiments on several types of chimney caps, influence of wind gradient.

In the Netherlands many types of chimney caps have been developed. In order to compare several types of chimney caps, wind tunnel experiments have been undertaken. (The Hague 1938, Gasstichting) Ref. 16)

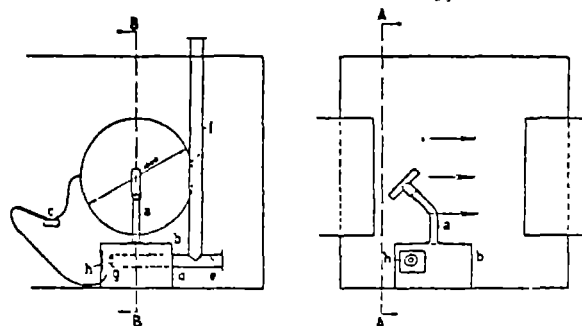

Fig. 2.4

View A-A

Cross-section B-B

Installation in windtunnel





The study finds a linear relation between :

I : Wind velocity ( $V_w$ ) and ventilation velocity ( $V_v$ )

II : Wind pressure  $P_w$  and underpressure  $\Delta p$ , measured by manometer c.

From the 34 types of chimney caps tested, the five shown in fig. 2.5 are of interest to us.

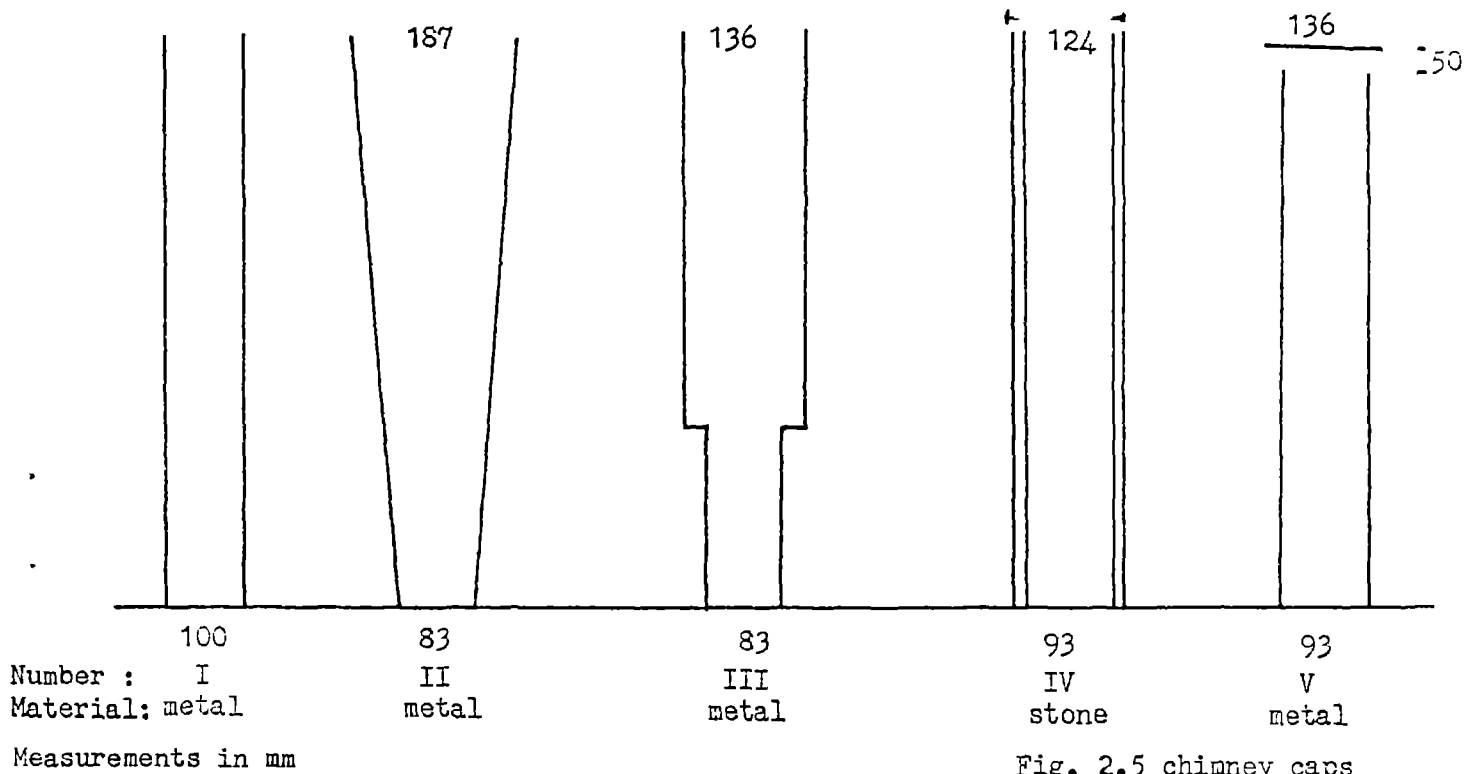

Fig. 2.5 chimney caps

The wind gradient has an influence on ventilation efficiency, as can be noticed in table 2.1. The table shows some of the results from the research done in 1938.



Table 2.1: Average value of  $\Delta p/P_s$  see fig. 2.4, ( $V_v=0$ ; wind velocities: 2.6  
5.7  
and 11.2 m/s)

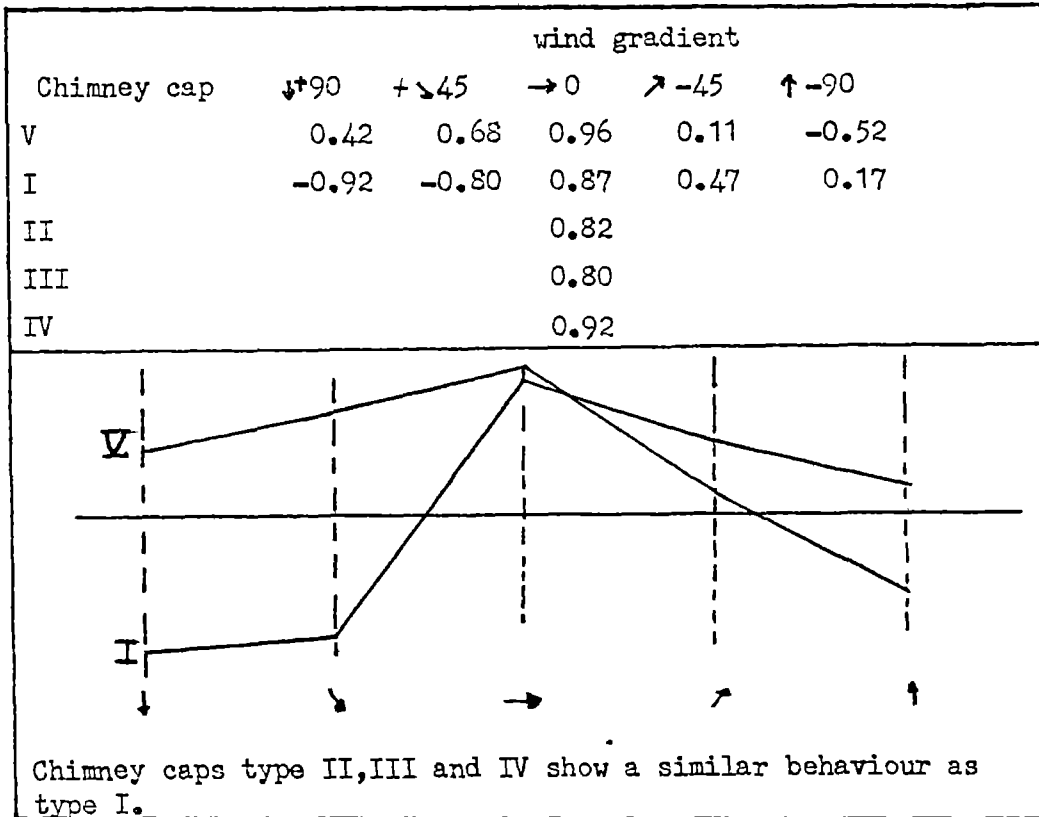

Fig. 2.6  
Representation  
of table 2.1

From table and figure can be concluded that for horizontal wind the draught will reach an optimum. (Ref 17 gives  $-5/-10^\circ$  as gradient as optimum).

Positive gradients will reduce ventilation efficiency very quickly. When the gradient exceeds  $+24^\circ$ , due to wind blowing into the top of the pipe an over-pressure is created, the difference in pressure will become negative.



## 2.4 Losses in flow

### 2.4.1 Pipes

The head loss due to friction may best be determined by the use of a rational formula:

$$H = \frac{2 f l v^2}{g d_i} \quad (1)$$

where

H = Head lost, metres of fluid flowing	(m)
f = Coefficient of friction (fig. 2.7)	(-)
l = Length of pipe	(m)
v = Velocity of air flow in vent-pipe	(m/s)
g = Acceleration due to gravity	(m/s <sup>2</sup> )
d <sub>i</sub> = Internal diameter of vent-pipe	(m)

The pressure loss per unit length of pipe (specific pressure loss) is given by :

$$\Delta p = \frac{\Delta P}{l} = \frac{H \rho g}{l} \quad (2)$$

where

$\Delta P$ = Pressure loss	(N/m <sup>2</sup> )
$\Delta p$ = Pressure loss per metre run of pipe	(N/m <sup>3</sup> )
$\rho$ = Density of fluid flowing	(kg/m <sup>3</sup> )

Combination of 1 and 2 gives

$$\Delta p = \frac{2 f v^2 \rho}{d} \quad (3)$$

The coefficient of friction f, is a variable dependent upon:

- a. the physical characteristics of the fluid flowing, the velocity of flow and the internal diameter of the pipe, with three components may be combined for consideration in terms of Reynolds Number, a dimensionless quantity:

$$(\text{Re}) = \frac{v d \rho}{\mu} = \frac{v d}{\nu} \quad (4)$$

where

(Re) = Reynolds Number	
$\rho$ = Density of fluid	(kg/m <sup>3</sup> )
$\mu$ = Absolute viscosity of fluid	(kg/ms)
$\nu$ = Kinematic viscosity of fluid	(m <sup>2</sup> /s)

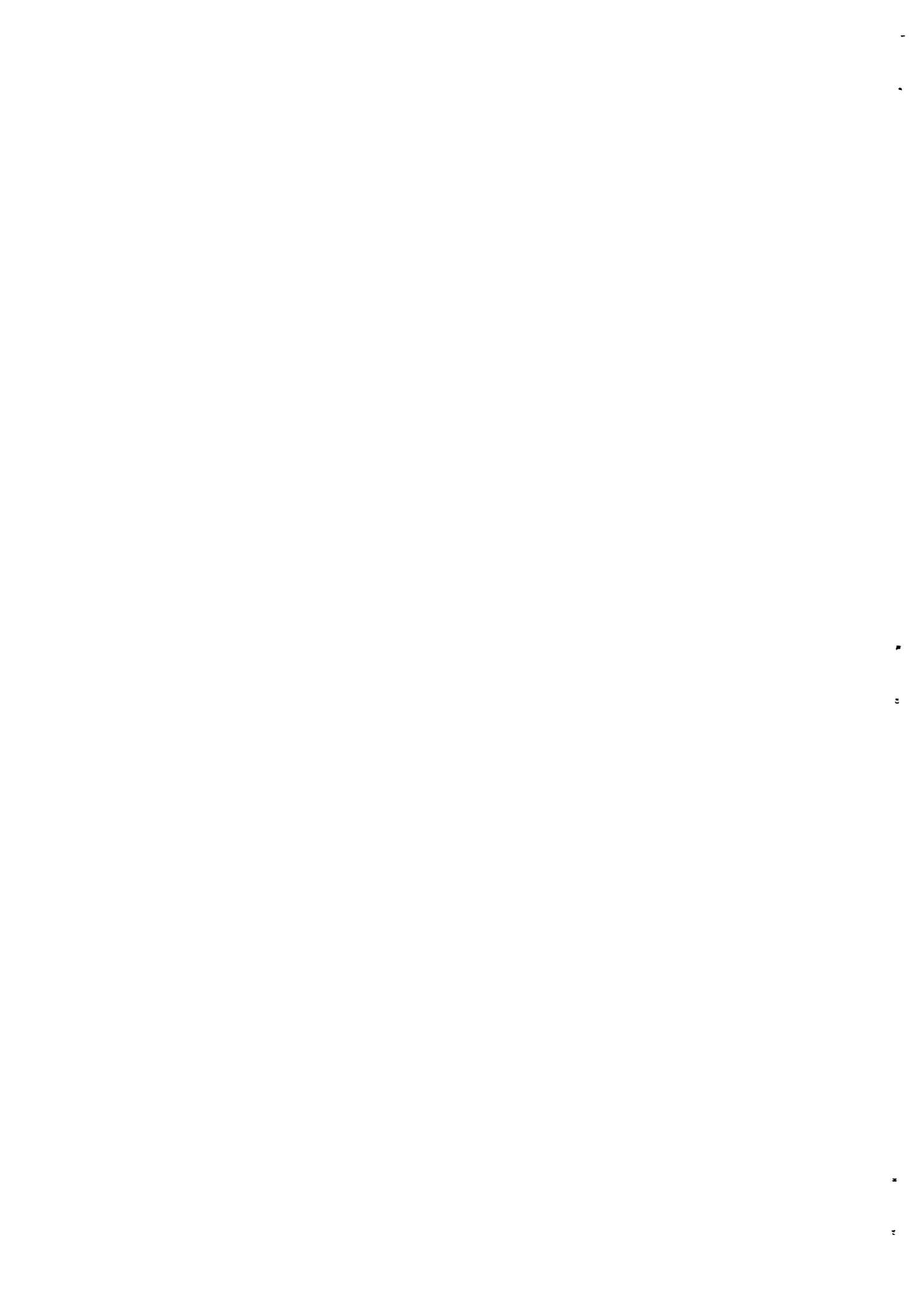

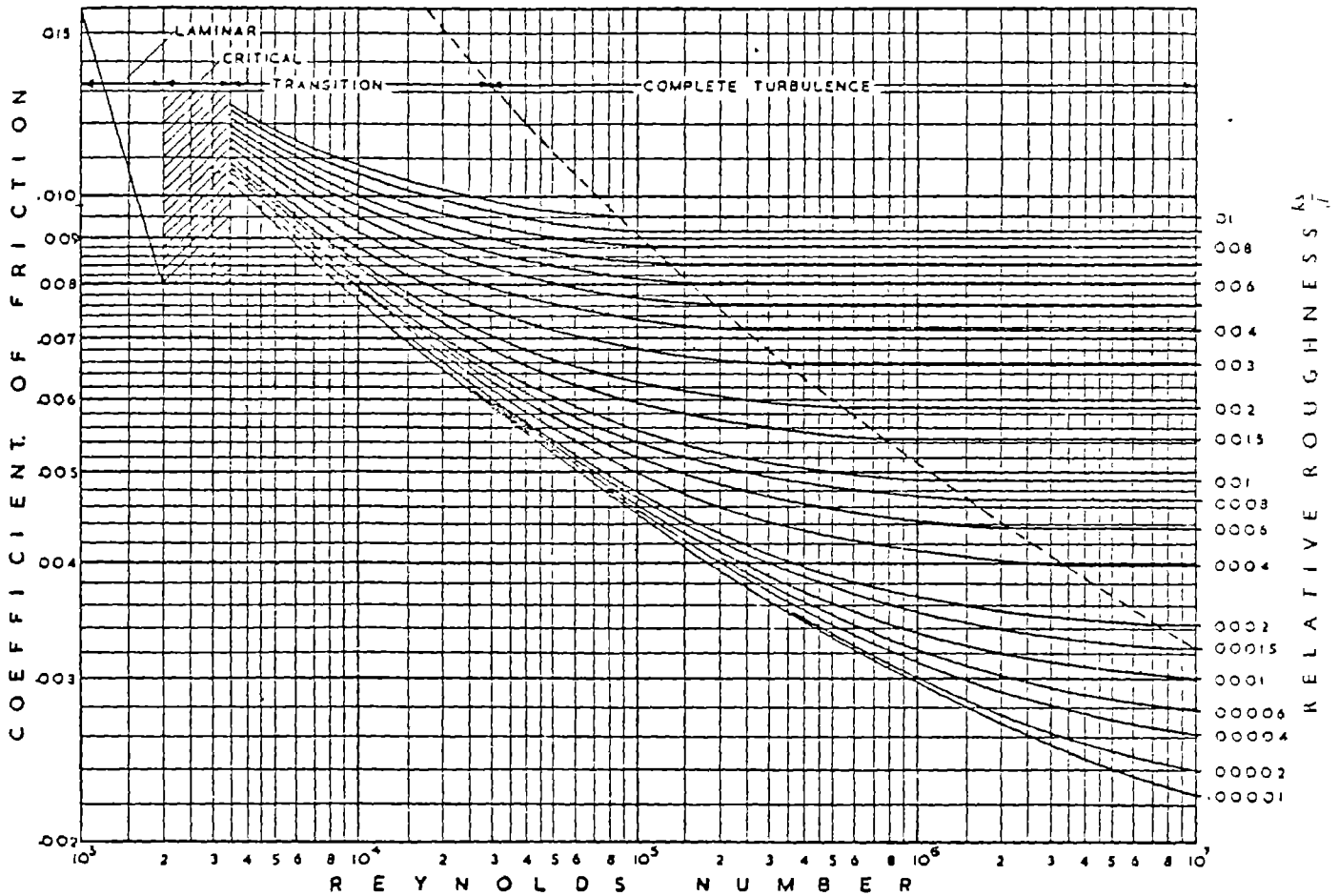

Fig. Relationship between roughness, friction and Reynolds Number

Fig.2.7

- b. The roughness of the pipe wall relative to the internal diameter, which is expressed in terms of a dimensionless ratio,  $k_s/d$ , where  $k_s$  is a lineal measure of absolute roughness having the same dimensional units as the diameter.

The relation between the coefficient of friction  $f$  and these components involves the use of the following expression:

(Re) < 2000

Here flow is streamline or laminar in character, the roughness of the pipe walls is not a significant factor and the coefficient of friction may be calculated from the formula of Poiseuille:

$$f = \frac{16}{(Re)} \quad (5)$$

(Re) > 3000

Here flow is turbulent and all the components previously discussed have value. The formula of Colebrook and White has now been generally accepted as being the best theoretical approach :



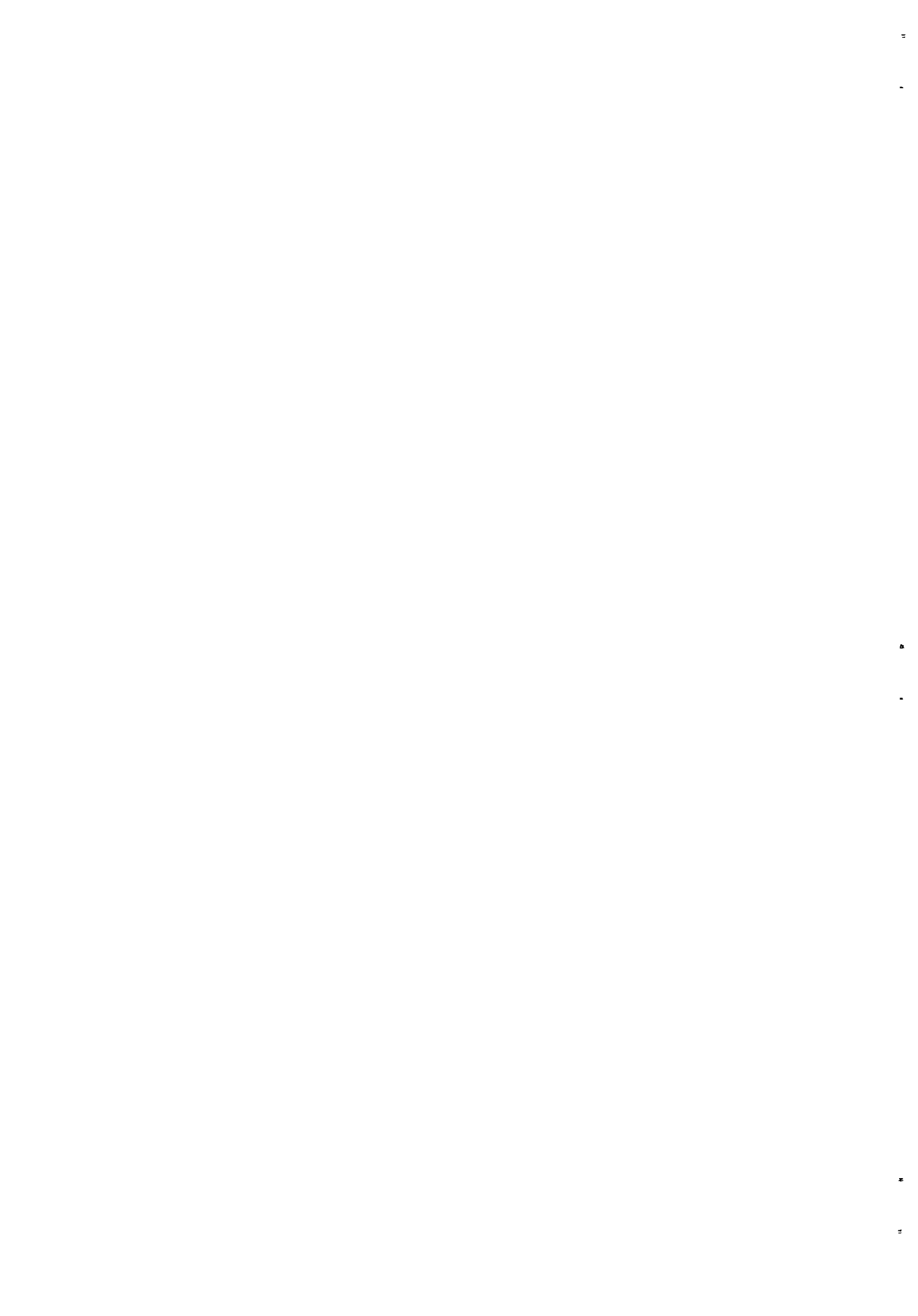

$$\frac{1}{\sqrt{f}} = -4 \log_{10} \left( \frac{k_s}{3.7 d} + \frac{1.255}{(Re)\sqrt{f}} \right) \quad (6)$$

#### 2.4.2 Mosquito gauze

The head loss due to mosquito gauze can be represented by the non-dimensional loss coefficient  $\lambda = \Delta Pt / \frac{1}{2} \rho v^2$

where:  $\Delta Pt$  is loss in pressure due to mosquito gauze/ $V$ =velocity of air flow in vent-pipe.

Knowing the characteristics of mosquito gauze :

$d_w$  diameter of the wire (m)

$n_1, n_2$  number of wires per linear meter in each di-

rection, it is possible to calculate the air flow head loss through the mosquito gauze as follows (ref.19):

- 1) Calculate the fly screen porosity,  $a$ , from the equation:

$$a = (1 - d_w n_1) (1 - d_w n_2)$$

- 2) Calculate the modified mosquito gauze Reynolds Number,  $R_m$ , from the equation:

$$R_m = Re (d_w / d_i a)$$

where  $Re$  is the standard Reynolds Number of air flow in the vent-pipe and  $d_i$  is the vent-pipe internal diameter (m).

- 3) Calculate the fly screen head loss coefficient,  $\lambda$ , from one of the empirical equations:

for  $R_m \leq 20$ :

$$\lambda = (33.93/R_m) \cdot ((1-a) / ((1+a) a^{1.27}))$$

for  $R_m > 40$ :

$$\lambda = (6/R_m^{1/3}) \cdot ((1-a) / a^2)$$

Interpolation for  $20 < R_m \leq 40$

$$\lambda = x + (R_m - 20) / (x - 4) / 20$$

$$x = (33.93 (1-a)) / (20 (1+a) a^{1.27})$$

$$y = (6(1-a)) / (3.4195 - a^2)$$



2.4.3 Calculation example, head loss

I due to friction

II due to mosquito gauze

- The formulae required are described in chapter 2.4.1 and 2.4.2.

extra information;  $\rho = 1.17(\text{kg/m}^3)$  ( $t=30^\circ$ )  
 $d_w = 0.25 \cdot 10^{-3}(\text{m})$   $\nu = 16.0 \cdot 10^{-6}(\text{m}^2/\text{s})$   
 $n1 = 5.5 \cdot 10^2$   $l = 2.80(\text{m})$   
 $n2 = 7 \cdot 10^2$   $k_s = 0.000015(\text{m})$   
 $a = 0.712$   $g = 9.8066(\text{m/s}^2)$

		$d_i = 0.105$	$0.14$	$0.213(\text{m})$
$V = 0.5 \text{ m/s}$				
	Re	3281	4375	6655
	l	0.011	0.0098	0.0086
	H	0.0144	0.0099	0.0058
I	$\Delta P$	0.1652	0.1136	0.0665 ( $\text{N/m}^2$ )
	Rm	11	11	11
	$\lambda$	0.506	0.506	0.506
II	$\Delta Pt$	0.074	0.074	0.074 ( $\text{N/m}^2$ )
$V = 1.0 \text{ m/s}$				
	Re	6562	8750	13312
	f	0.0087	0.008	0.0071
	H	0.0473	0.0328	0.0193
I	$\Delta P$	0.5427	0.3763	0.2214
	Rm	22	22	22
	$\lambda$	0.404	0.04	0.04
II	$\Delta Pt$	0.236	0.236	0.236
$V = 2.0 \text{ m/s}$				
	Re	13125	17500	26625
	f	0.0071	0.0067	0.0061
	H	0.1566	0.110	0.652
I	$\Delta P$	1.7968	1.2621	0.7481
	Rm	44	44	44
	$\lambda$	0.966	0.966	0.966
II	$\Delta Pt$	2.26 ( $\text{N/m}^2$ )	2.26	2.26

Table 2.2 Head loss calculations

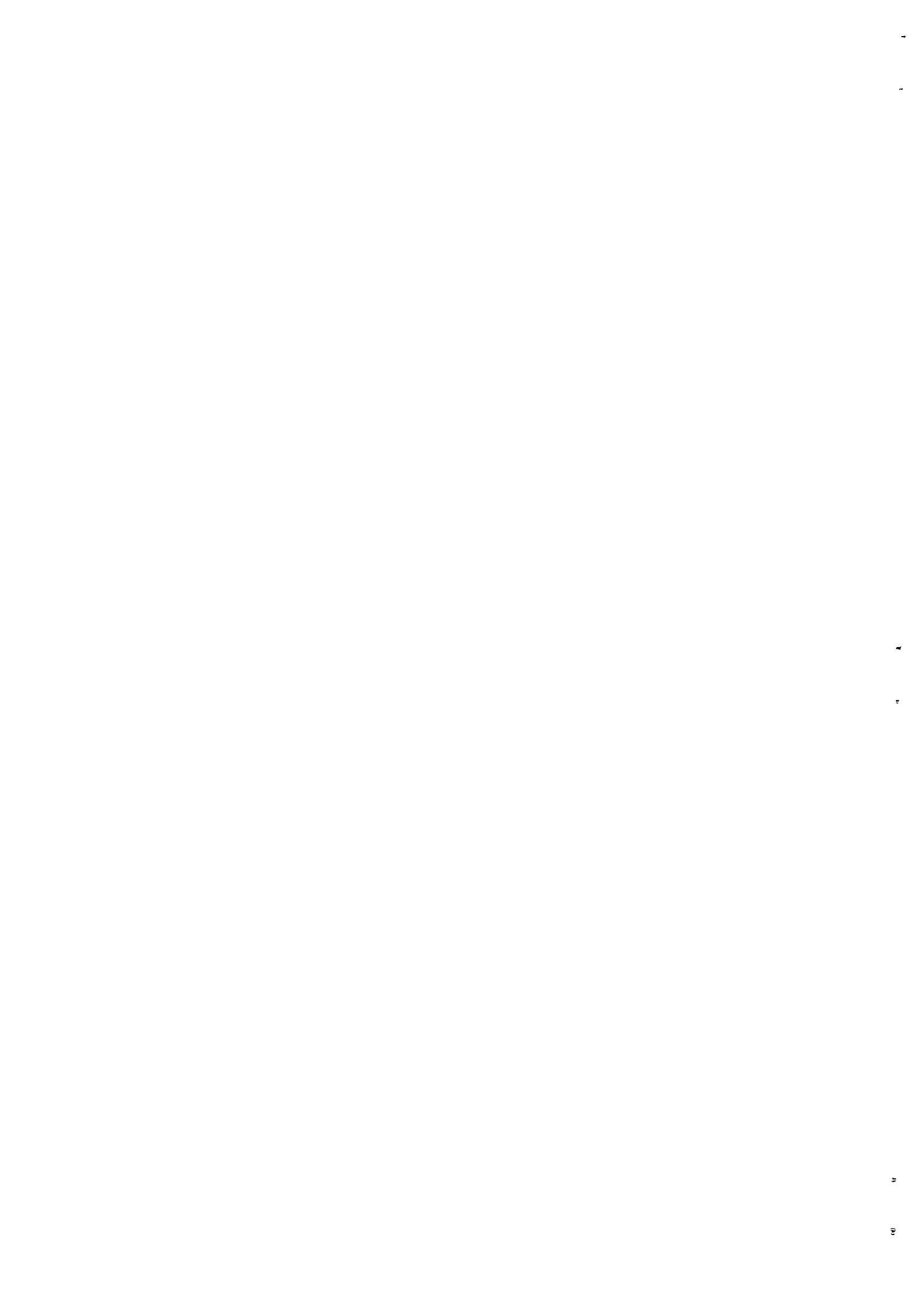

I friction :

- increasing diameter shows a reduction in pressure-loss
- increasing ventilation velocity results in an increasing pressure loss.

II mosquito gauze

- diameter has no influence on pressure loss ( $N/mm^2$ )
- ventilation velocity has a significant influence on pressure loss.

The high pressure loss with ventilation velocities above 1 (m/s) is however not of interest to us, because the minimum required ventilation velocity for the smallest diameter, 4" or 0.10 (m), is 0.86 (m/s) ( 4" - 0.86 ; 6" - 0.38 ; 8" - 0.21 (m/s)).

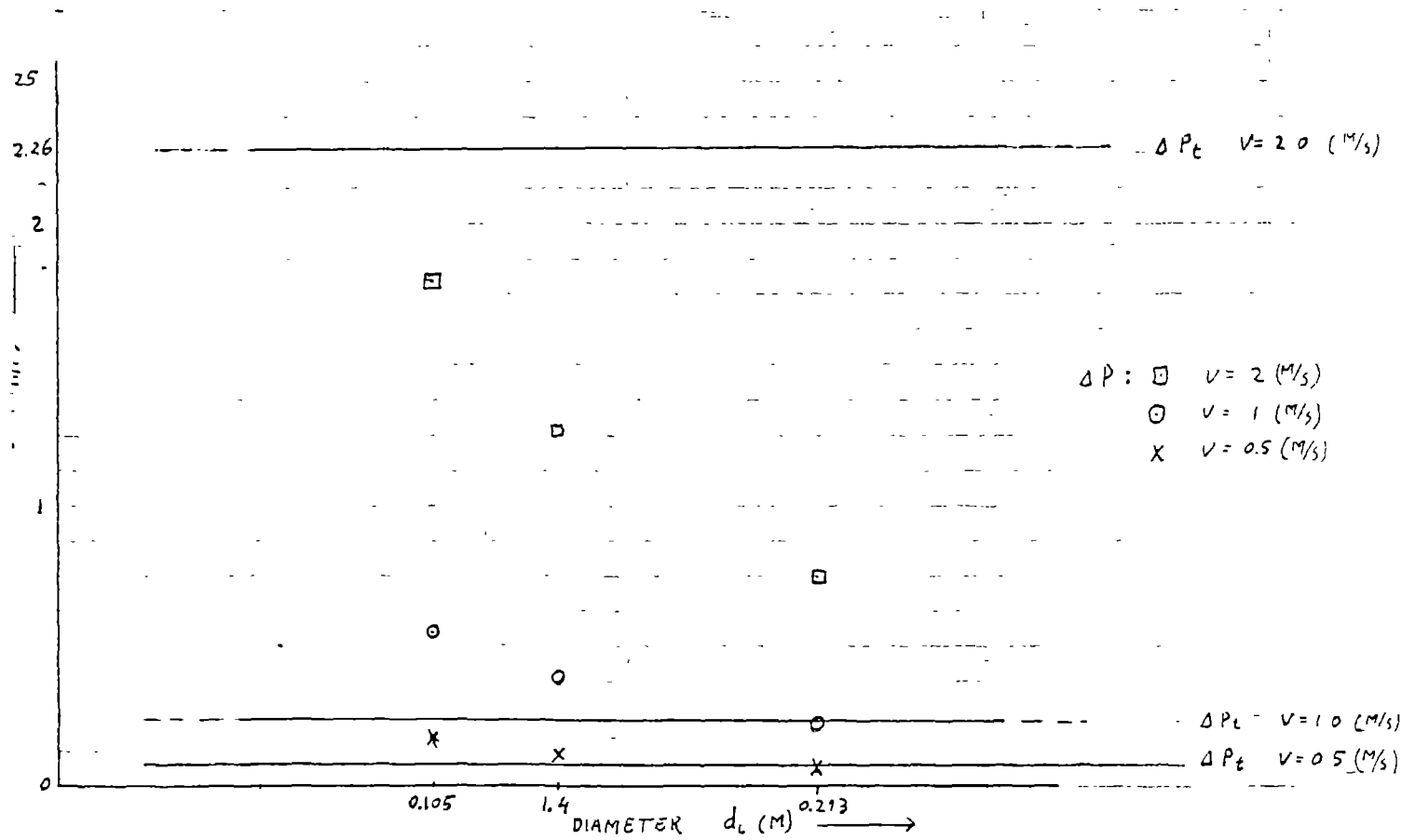

Fig. 2.8 Losses in flow  
 I  $\Delta P$  due to friction  
 II  $\Delta P_t$  due to mosquito gauze



## 2.5 Influence of Temperature on Ventilation

It is not difficult to realize that temperature, and to be specific a difference in temperature, will influence ventilation.

The density of air is different for different temperatures.

As we look at table 2.3 we see that f.i. the density at 0 °C is  $\rho = 1.29 \text{ (kg/m}^3\text{)}$  and for t is 30 °C  $\rho = 1.17 \text{ (kg/m}^3\text{)}$ .

Table 2.3 Some properties of air

Air \ Temp. °C	0	10	20	30	
$\rho \text{ (kg/m}^3\text{)}$	1.29	1.25	1.21	1.17	Density
$\nu \text{ (10}^{-6} \text{ m}^2\text{/s)}$	13.3	14.2	15.1	16.0	Kinematic viscosity

The difference in temperature between the air inside the pit and the ambient outside temperature causes a pressure.

Lüftungsanlagen im Wohnungsbau pp. 17 (ref.4) gives the following formula :

$$\Delta p = h \rho \frac{\Delta t}{273} \quad (\text{kg/m}^2) \quad (1)$$

$$\Delta p = \text{pressure arising} \quad (\text{kg/m}^2)$$

h = vertical distance between inlet and outlet openings (m)

$$\Delta t = \text{difference in temperature} \quad (^\circ\text{C})$$

$$\rho = \text{density} \quad (\text{kg/m}^3)$$

The IHVE Guide calles the influence of temperature "Stack Effect". Their equation for calculating the pressure in a building due to the inside/outside temperature difference is:

$$\Delta p = 3462 h \left( \frac{1}{t_o + 273} - \frac{1}{t_i + 273} \right) \quad (2)$$

$$t_o = \text{outside temperature} \quad (^\circ\text{C})$$

$$t_i = \text{inside temperature} \quad (^\circ\text{C})$$

$$\Delta p = \text{pressure arising} \quad (\text{N/m}^2)$$





This difference in pressure results in a ventilation velocity, if we forget flow-resistance, of

$$v = (2g \cdot p/\rho)^{\frac{1}{2}}$$

$v$  = ventilation velocity (m/s)  
 $p$  = pressure calculated (kg/m<sup>2</sup>)  
 $g$  = 9.814 (m/s<sup>2</sup>)

Figure 2.9 shows the theoretical ventilation velocity due to difference in temperature for several shaft-heights, according formula (1).

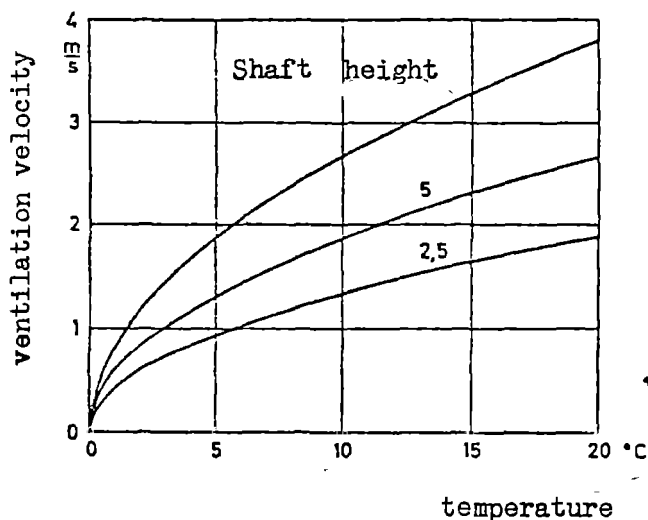

10 Fig. 2.9  
 Theoretical ventilation velocity, depending on difference in temperature and shaft height.

Calculation example.

In Dar es Salaam the temperature does not fluctuate very much during over 24 hours. The effect of day and night on temperature in and around a VIP latrine can be seen in fig. 2.10 (Measured on 20 Jan. 1982, Vip latrine Kiwilani/DSM, 6" vent-pipe).



Hour	T3	T6	$\Delta T=(T_3-T_6)$
08 AM	29.2	28.3	0.9
10 "	30.2	29.0	1.2
12 "	31.9	29.9	2.0
02 PM	33.0	31.1	1.9
04 "	32.3	31.7	0.6
06 "	31.8	31.2	0.6
08 "	29.8	30.7	0.9
10 "	29.2	30.0	0.8
12 "	28.9	29.8	0.9
02 AM	28.1	29.3	1.2
04 "	27.8	28.8	1.0
06 "	27.6	28.5	0.9

Table 2.3 :  
Temperatures  
over 24 hours  
in VIP latrine.

Temperature T6 : temperature inside pit  
" " T3 : ambient outside temperature.

Both temperatures follow the same pattern during day and night.  
A positive (negative) effect on ventilation can be expected if  
 $T_3 > T_6$  ( $T_3 < T_6$ )

$\Delta T$  ranges between + 2.0 and - 1.2

$$\Delta T = +2; \Delta P (1) 0.236 \text{ N/m}^2 \quad \Delta P (2) = 0.210 \text{ N/m}^2$$

$$\Delta T = -1; \Delta P (1) -0.141 \text{ N/m}^2 \quad \Delta P (2) = -0.128 \text{ N/m}^2$$

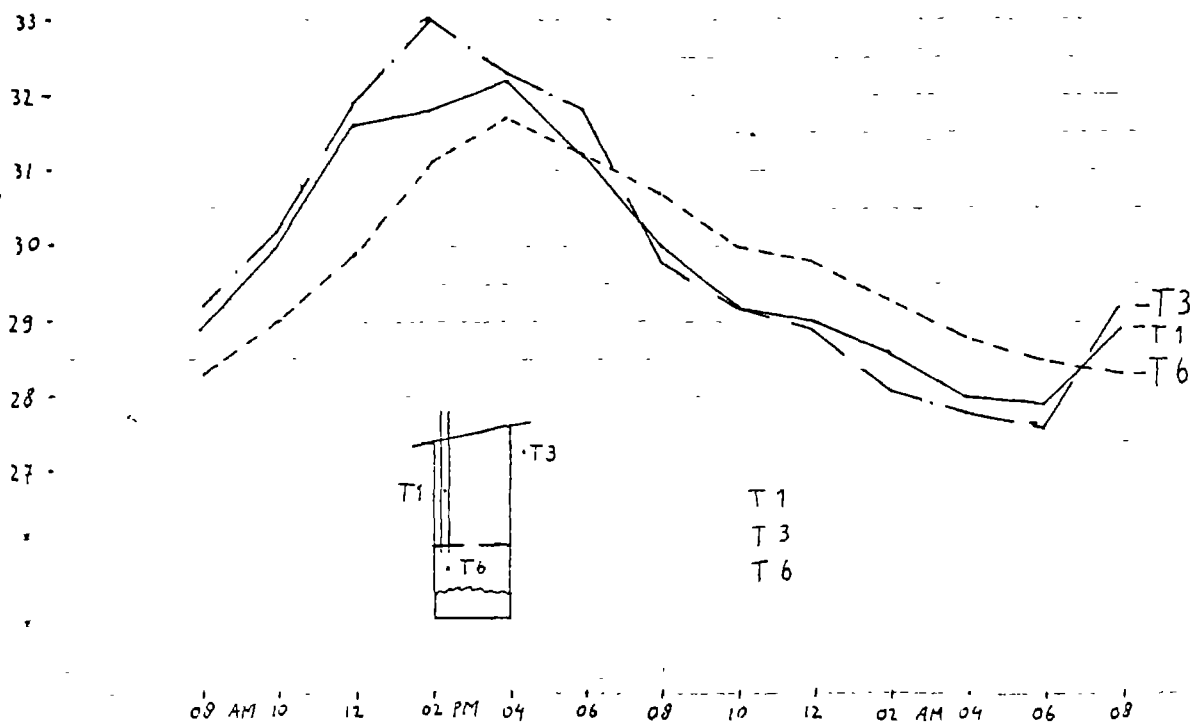
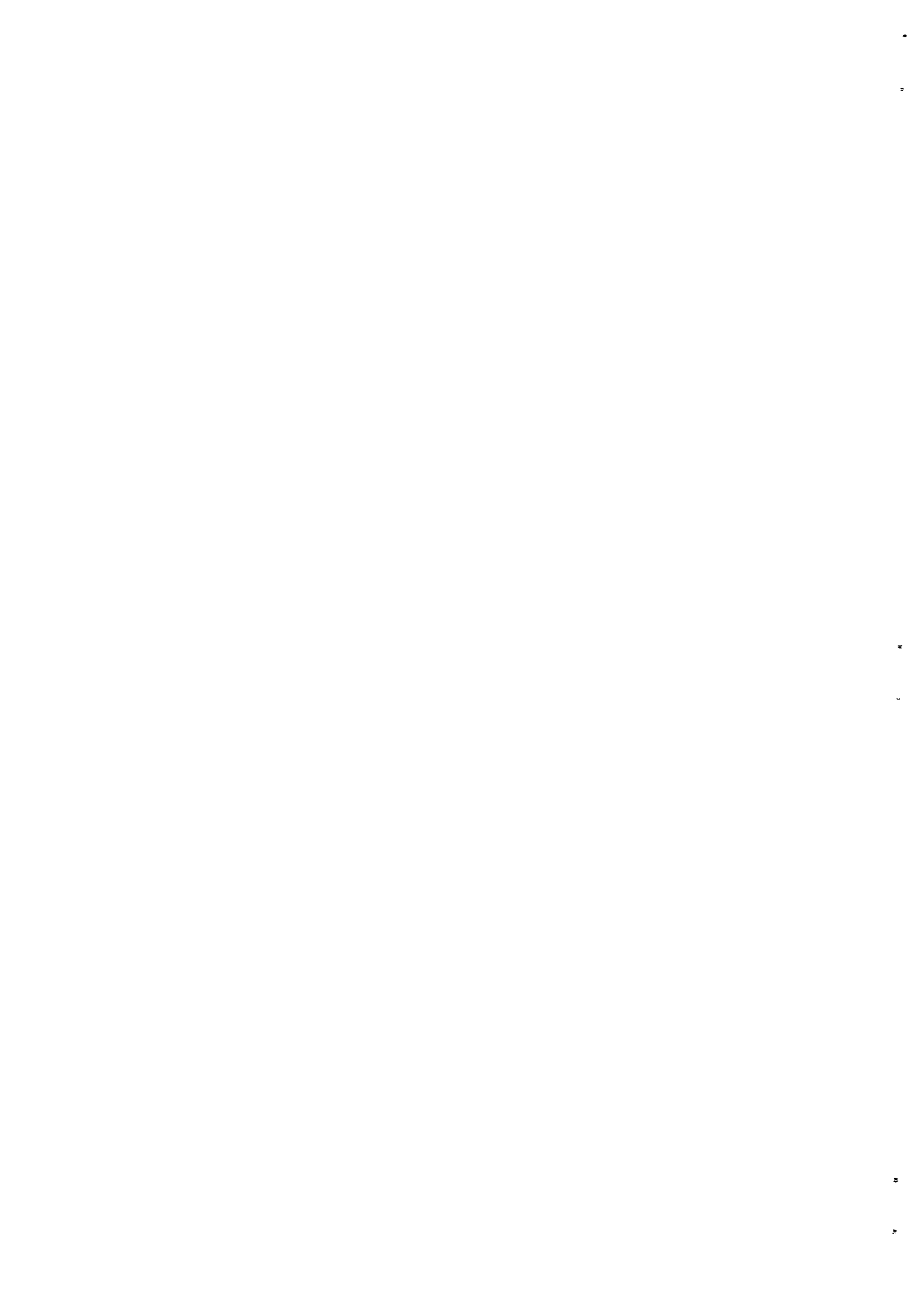

Fig. 2.10  
Temperatures  
over 24 hours  
in VIP latrine  
(20 jan 1982  
DSM/Tanzania)



## 2.6      Conclusions

The main conclusions are :

- There is a linear relation between draught and wind velocity.
- The draught will reach an optimum in velocity when the main flow, wind, is perpendicular in direction to the ventilation pipe.
- A positive wind gradient has a negative effect on ventilation efficiency, for a simple open vent-pipe. (fig. 2.6)
- The character of flow in a vent-pipe is turbulent.
- Flow resistance, due to mosquito gauze and friction of the pipe wall, depends much on flow velocity.  
The minimum ventilation velocities, less than 1 m/s, are not significantly reduced by flow losses.
- The effect of sun radiation can be either positive or negative, depending on the difference in temperature in- and outside the latrine. Due to the small difference in temperature, the effect is little. The advantage however is that the positive effect will occur during the night when wind velocity can be low.



3.1 Introduction

The field study was executed in August 1982 at the Building Research Unit (BRU) in Dar es Salaam. Regarding the necessity of exchanging vent-pipes an experimental VIP latrine was built (Fig. 1.3;1.4;1.5 and 3.1). The measurements took place during day-time.

Appendix 3 gives exact information on weather conditions and day programme. This chapter deals with the test-site, equipment and test-programme.

3.2 Wind condition in Dar es Salaam

Because wind is essential for a VIP latrine, some information about the wind situation along the Tanzanian coast is given. Tanzania is experiencing the North-East trade winds from november to March and the South-East trade winds from april to october. The monsoon pattern is part of the global climate. This pattern is modified by the land masses. Thus, along the Tanzanian coast the sea breezes are modified. The diurnal pattern of sea-land breezes during day-time and to less extent, the land sea breezes during the night are distinct. This pattern reaches upto 8-10km inland, depending upon topography.

Late nights are often calm, during the mornings the sea-land breezes develop and at 10.00 AM wind speeds range between 3-5 m/s. The sea-land breeze reaches a peak in the mid-afternoon, when wind speeds decline towards the evening. Land-sea breezes start late in the evening and continue until dawn, with wind speeds much lower than during the day.





### 3.3 Description of the installation

#### 3.3.1 VIP latrine at BRU

Figure 3.1 shows the latrine as built. It is a square latrine, inside  $1 \text{ m}^2$ , from which the slab level is put on  $0.95 \text{ m}$  above the ground level because of the high ground water table. The vent-pipe is located inside. Ventilation openings (see fig. 1.6 and 3.2):

- Front side, above door  $1100 \text{ cm}^2$
- Two small openings 80 "
- Side walls (each) 160 "
- Back side 440 "
- Key-hole 655 "

Walls and foundation :

Cement/sand stones, thickness of  $5 \text{ cm}$ .

Roof:

Sisal reinforced sheets

The VIP latrine stands relatively in the open. The wind can approach the VIP latrine from any side.

No trees or buildings are located in the near vicinity. The nearest building is the BRU building itself, on a distance of approximately  $30 \text{ m}$ .

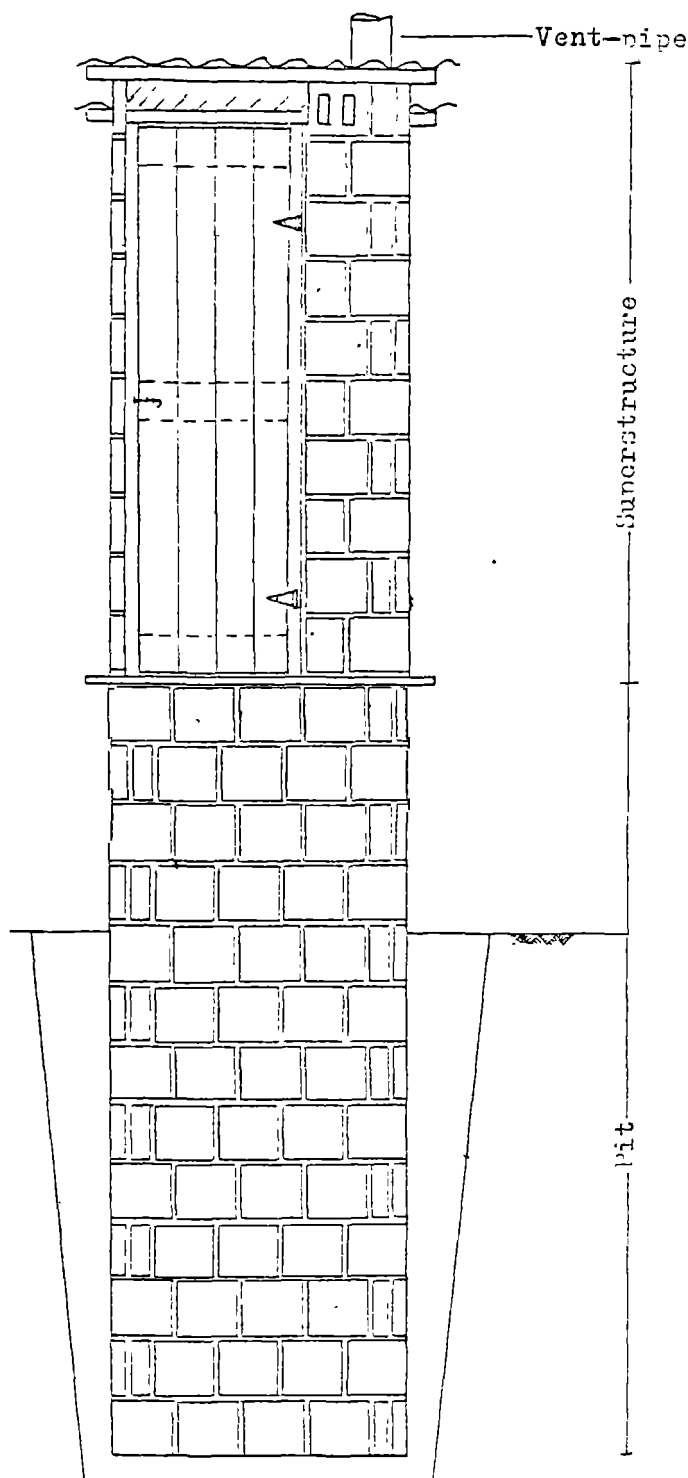

Fig. 3.1 Front side VIP latrine built at the BRU, Dar es Salaam, Tanzania.



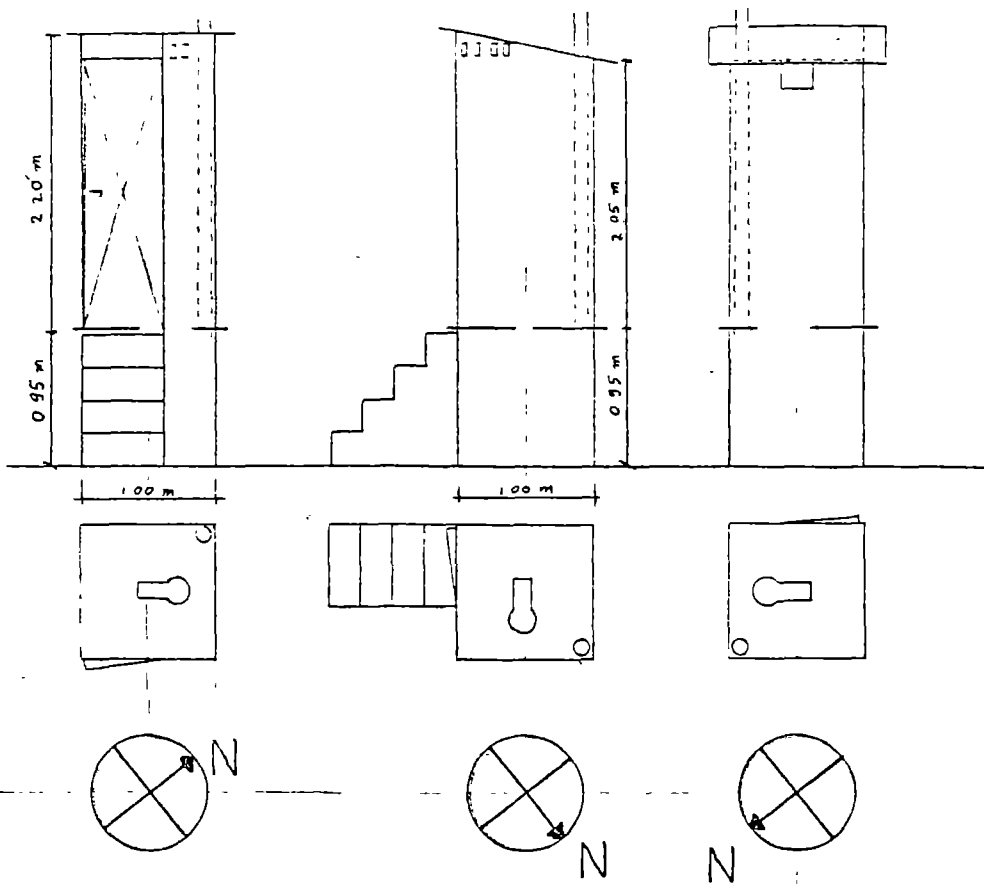

Fig. 3.2 Schematic drawing of VIP latrine, including North indication.



3.3.2      Equipment

In order to get an idea of the ventilation, the velocity of the flow of air going upwards in the vent-pipe is measured. Half-way the vent-pipe a pitot tube is fixed to the vent-pipe. The pitot tube is connected to a micromanometer. The ventilation velocity creates a difference in pressure. This difference in pressure is converted by the apparatus back to velocity (m/s) The velocity results are put on charts (chart speed 6 inch/h).

To find the wind velocity and direction nearby the top of the vent-pipe, an anemograph is located in the vicinity of the top of the vent-pipe.

Fig.3.5 shows the installation.

The anemograph consists of an anemometer and a windvane. The anemometer records the wind speed and the windvane records the wind direction. The results of the anemometer and the windvane are put on charts (chart speed 3 inch/h).

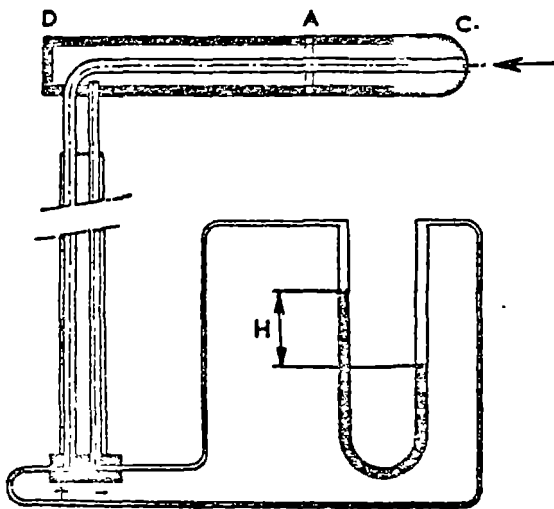

$$H = \frac{1}{2} \cdot \rho \cdot v^2$$

Fig. 3.3 Pitot-tube

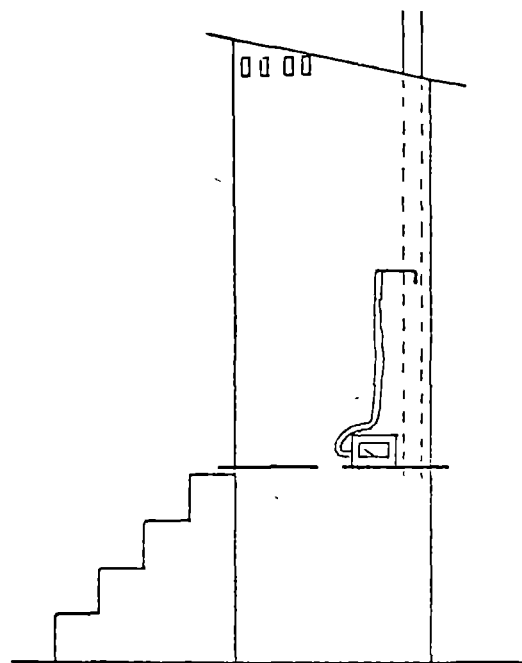

Fig.3.4 Location pitot-tube.





Fig. 3.5 VIP latrine at BRU, including anemograph.



Fig.3.6 View of front side, taken from the top of the VIP latrine. To the left, BRU building. To the right, a bakery.





### 3.4 Parameters selected

As mentioned in chapter 2 on factors influencing ventilation, the following are selected.

#### 1. Diameter vent-pipe

The Dar es Salaam Demonstration project has installed VIP latrines with either 4 or 6 inches vent-pipes. Both types work reasonably, but the idea is that the 6" vent-pipe ventilates better.

The exact influence, if there is any, of diameter on ventilation velocity (m/s) induced by wind velocity is not known.

The reason for choosing three different diameters is the hope to find the optimum one within these differences. Chosen is for a 4", 6" and 8" vent-pipe. If the diameter has no influence on ventilation velocity, then there might be a significant influence of diameter on ventilation rate (m<sup>3</sup>/s). On the other hand one should bare in mind, that especially for the very expensive PVC vent-pipe material costs increase significantly with increasing diameter.

The pipes used in the tests are made of PVC.

Vent-pipe (inch)	Dian.(inside) (cm)	(Outside) (cm)	Thickness (cm)	cross-section (cm <sup>2</sup> )
4"	10.5	11.0	0.25	86.6
6"	14.0	16.0	1.00	153.9
8"	21.3	22.7	0.70	56.3

Table 3.1 Information on vent-pipes used

#### 2. Location of the vent-pipe

The location of the vent-pipe in relation to the door, roof or squatting slab might have some influence (see parameter 3) Three positions are selected.

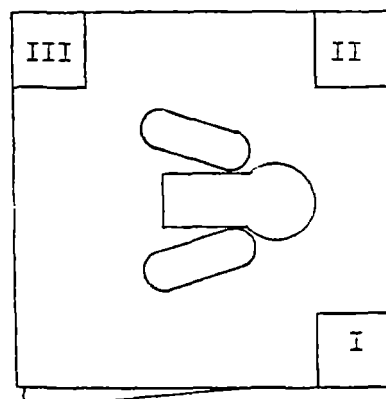

Possible locations for putting a vent-pipe.

Fig. 3.7



### 3. Height of the vent-pipe above the roof/length of the vent-pipe

Fig. 3.8 Top of VIP latrine.

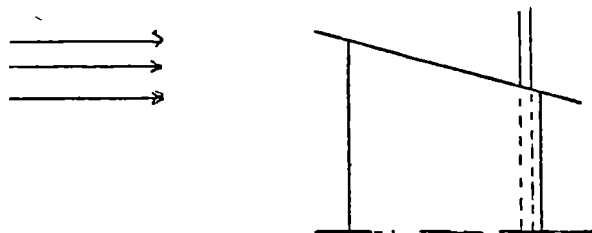

The roof is built under a certain slope, to have rain directed backwards. It is possible that the wind near the top of the vent pipe doesn't move horizontally, but somehow under a certain angle, depending on wind direction and location of the vent-pipe. A short vent-pipe will experience more influence of the roof than a long vent-pipe.

Location I Length slab-roof 2.27 m.

Location II and III Length slab-roof 2.12 m.

Pipe length (m)	Height roof-top vent-pipe	
	Loc.I	Loc.II/III (m)
2.40	0.13	0.28
2.55	0.28	0.43
2.80	0.53	0.68

Table 3.2 Relation between length, height roof-top and location of the vent-pipe.

### 4. The use of enlargers

An enlarger is a piece of the vent-pipe with a larger diameter as the vent-pipe from the slab upto the roof. An enlarger is put on top of the vent-pipe.

Ventilation is created by wind blowing over the top of the vent-pipe. There are two reasons to experiment with enlargers.

1. If only the top is important in creating ventilation, than it is possible that a 4" vent-pipe with a 6" enlarger will have the same result in  $m^3/s$  as a 6" vent-pipe. An important reduction in material cost can be achieved.
2. When mosquito gauze is used, it will decrease the open area at the top, resulting in flow resistance. Increasing the diameter of the top of the vent-pipe will decrease flow resistance induced by the mosquito gauze.

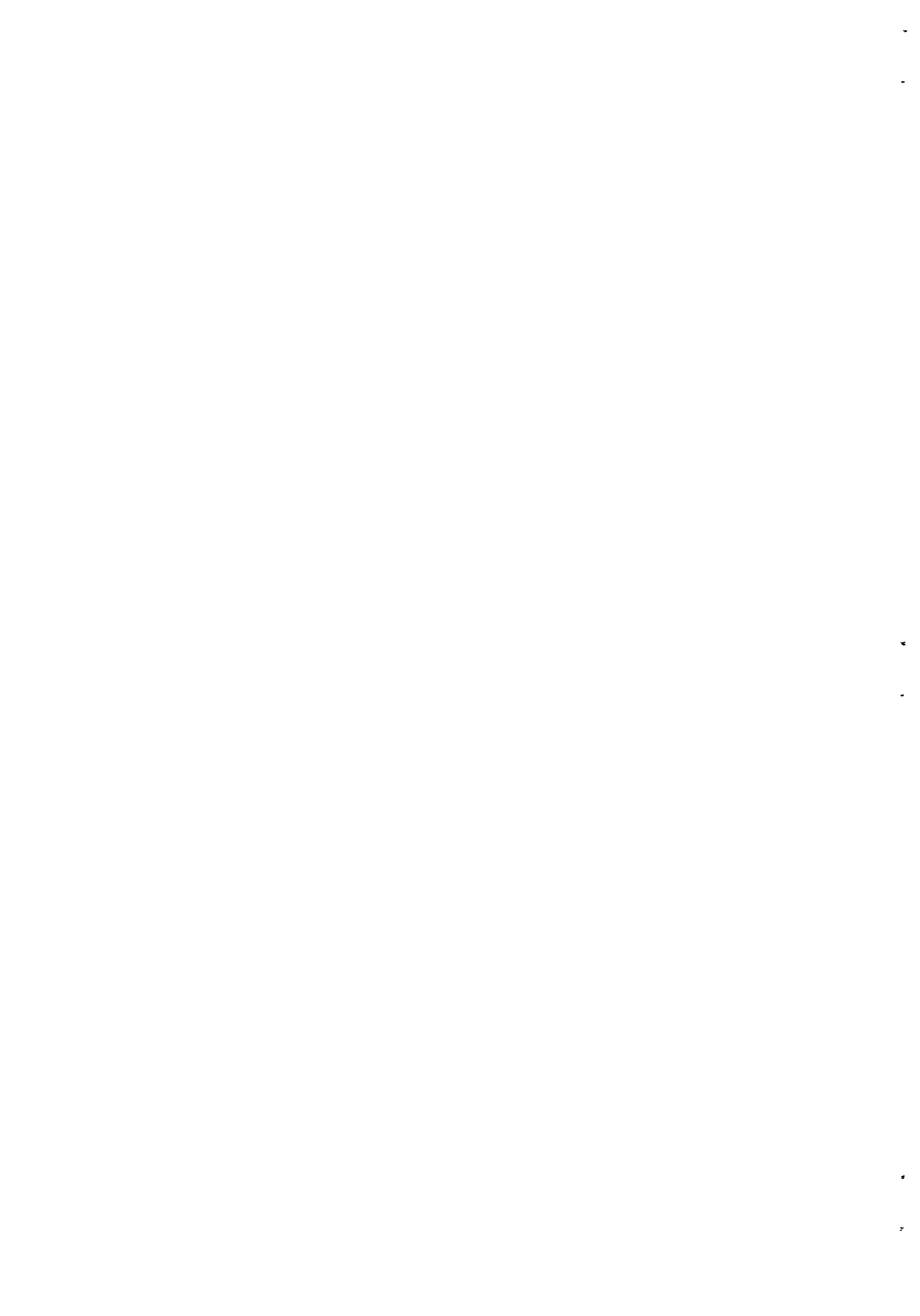

Two combinations are tested :

- a 4" vent-pipe with a 6" enlarger and
- a 6" vent-pipe with a 8" enlarger

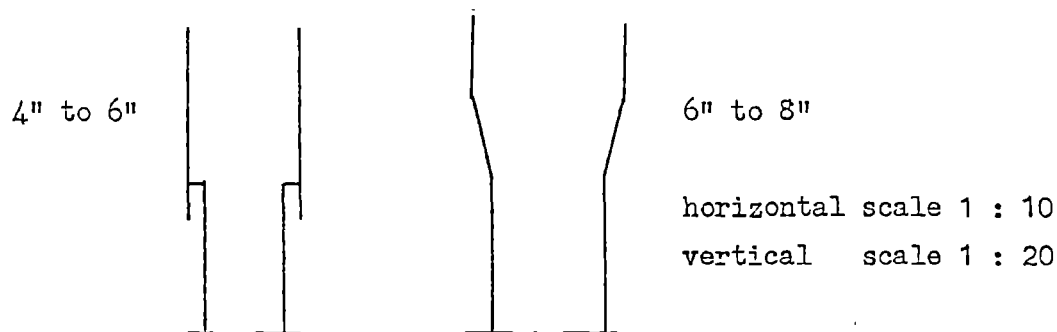

Fig. 3.9 Enlargers

### 5. Mosquito gauze

The function of a vent-pipe is not only ventilation, but also to work as a fly-trap. Flies attracted by the light coming from the top of the vent-pipe, want to use the vent-pipe as exit. The way out through the vent-pipe can be blocked by mosquito gauze. It is logic that due to the mosquito gauze there will be a reduction in the ventilation velocity. (chapter 2.4)

Fig. 3.10

Mosquito gauze on top of vent-pipe.

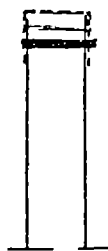

The mosquito gauze is put flat on top of the vent-pipe and fixed to it with an elastic.

### 6. Cover

A way to keep the pit dark and to prevent smell from the pit into the superstructure is by putting a cover on the key-hole. A disadvantage of using a cover is that it will be a significant barrier for air flow.

Fig. 3.11

Cover

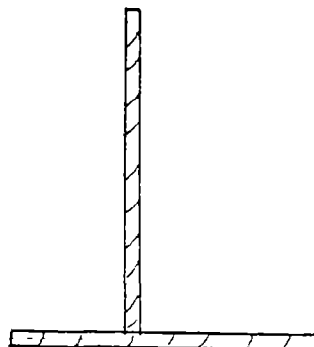
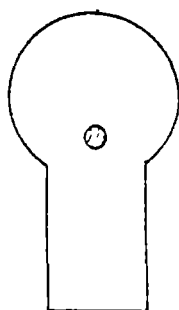

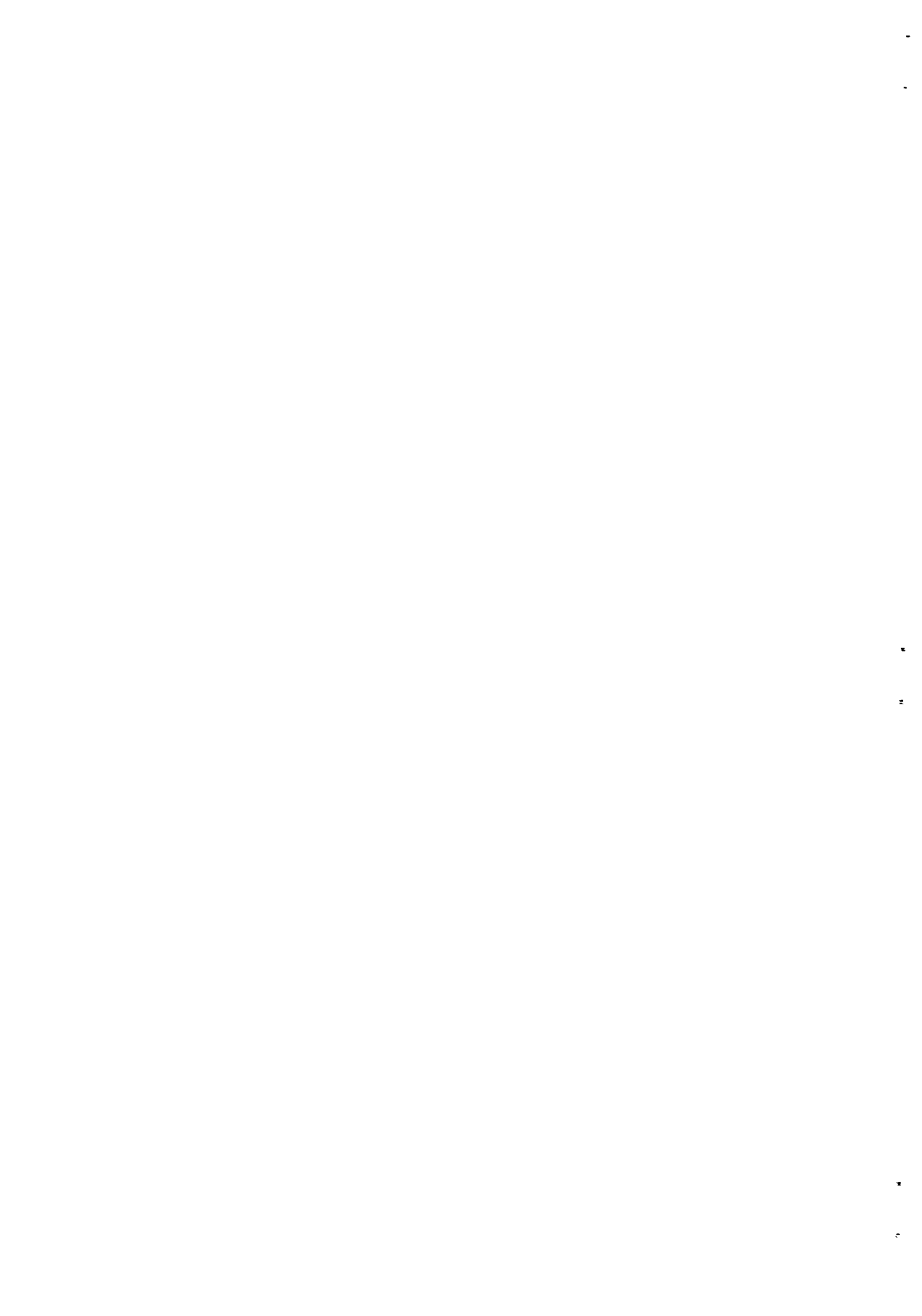

### 7. Door open/closed

The VIP latrines built in the Unicef rural sanitation project in Iringa, Tanzania, are not equipped with doors, but L-shaped walls should guarantee privacy.

Although the VIP latrine at the BRU doesn't have a L-shaped wall, it seemed interesting what would be the result when the door is kept open during the measurements.

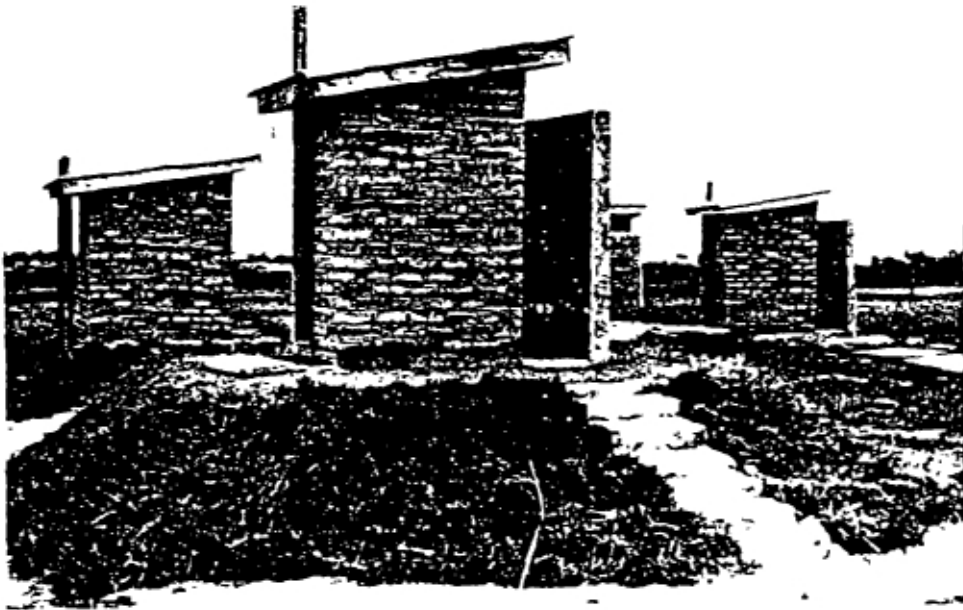

Fig. 3.12 Vip latrine equiped with L-shaped wall.  
(Unicef rural sanitation project,Tanzania)





### 3.5 The test programme

Testing each alternative of the seven parameters would require 240 tests/measurements.

#### Parameter

1+4	diameter	5	4", 4"+enl. 6", 6", 6"+enl. 8", 8".
2	location vent-pipe	3	I, II and III
3	length vent-pipe	3	2.40m, 2.55m, 2.80m
5	mosquito gauze	2	yes/no
6	cover	2	yes/no
7	door open	2	yes/no

The most important parameters considered, before starting the measurements, were diameter and mosquito gauze.

The 6" vent-pipe is chosen as reference diameter. The alternatives of parameter 2, 3, 6 and 7 are carried out with a 6" vent-pipe.

Measurements with mosquito gauze are executed for one position and on the longest vent-pipe. The idea is that the longest vent-pipe length will evince no influence of position.

Therefore is chosen for the following programme, limited to 29 measurements.

Door open	NO											YES			
Cover	NO											YES	YES	NO	
Mosquito gauze	NO											YES	NO	YES	NO
Position	I			II			III			II	II	II	II		
Length	a	b	c	a	b	c	a	b	c	c	c	c	c		
Diameter 4"	-	-	B1	-	-	B2	-	-	B3	D1	-	-	-		
4"+enl. 6"	-	-	B4	-	-	B5	-	-	B6	D2	-	-	-		
6"	A1	A2	A3	A4	A5	A6	A7	A8	A9	D3	C1	C2	C3		
6"+enl. 8"	-	-	B7	-	-	B8	-	-	B9	D4	-	-	-		
8"	-	-	B10	-	-	B11	-	-	B12	D5	-	-	-		

Table: 3.3 survey test programme

a: 2.40 m b: 2.55m c: 2.80m

-: not covered

A6: code of specific test



## Chapter 4

## Recording and evaluation of the results

### 4.1

### Recording of the results

Each measurement, A1, A2 etc., will take at least one hour.

Two charts are being produced.

Chart 1 : On this chart the ventilation velocity, the velocity of the flow of air going upwards in the vent-pipe is dotted on pressure sensitive paper. This paper is moving with a speed of six inch per hour. The scale is from 0-10 m/s, chart width 5.9 cm.

Chart 2 : This chart gives the results of the anemograph. Total chart width 2.6 inches, chart width per channel 1.0 inch. Chart speed three inches per hour. The left channel indicates the wind velocity, scale from 0-10 m/s. The right channel gives the results of the windvane, wind direction.

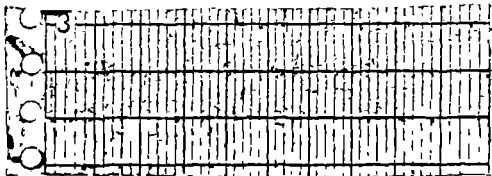

Fig. 4.1 Chart 1,  
ventilation velocity

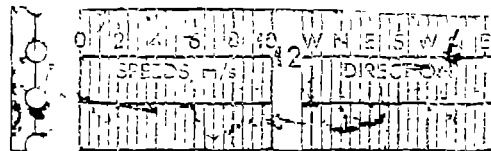

Fig.4.2 Chart 2,  
anemograph

During the measurements it was noticed, as expected, that there would be a strong correlation between wind velocity and ventilation velocity. Both parameters were displayed on panel meters, which showed a similar behaviour. To make the correlation visual, I enlarged chart 2 two times.

It is very difficult to read the results from the charts. Therefore all recordings are photocopied and lines are drawn on the photocopies, following the pattern of the points. (Fig.4.3)

One line indicates wind velocity, the other line ventilation velocity. In order to find a characteristic relation, approximately thirty corresponding wind/ventilation point are randomly chosen.



A2

A2

30

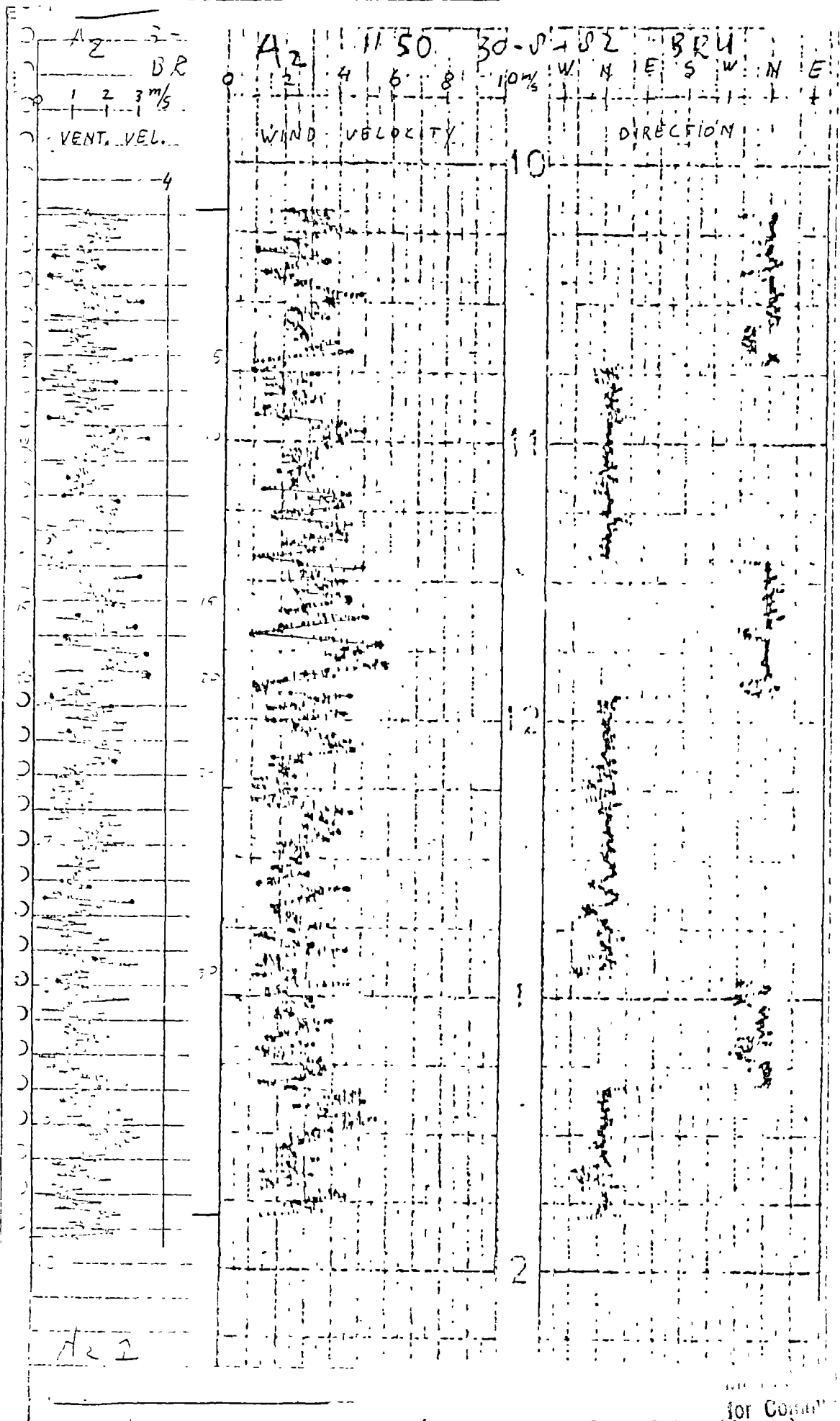
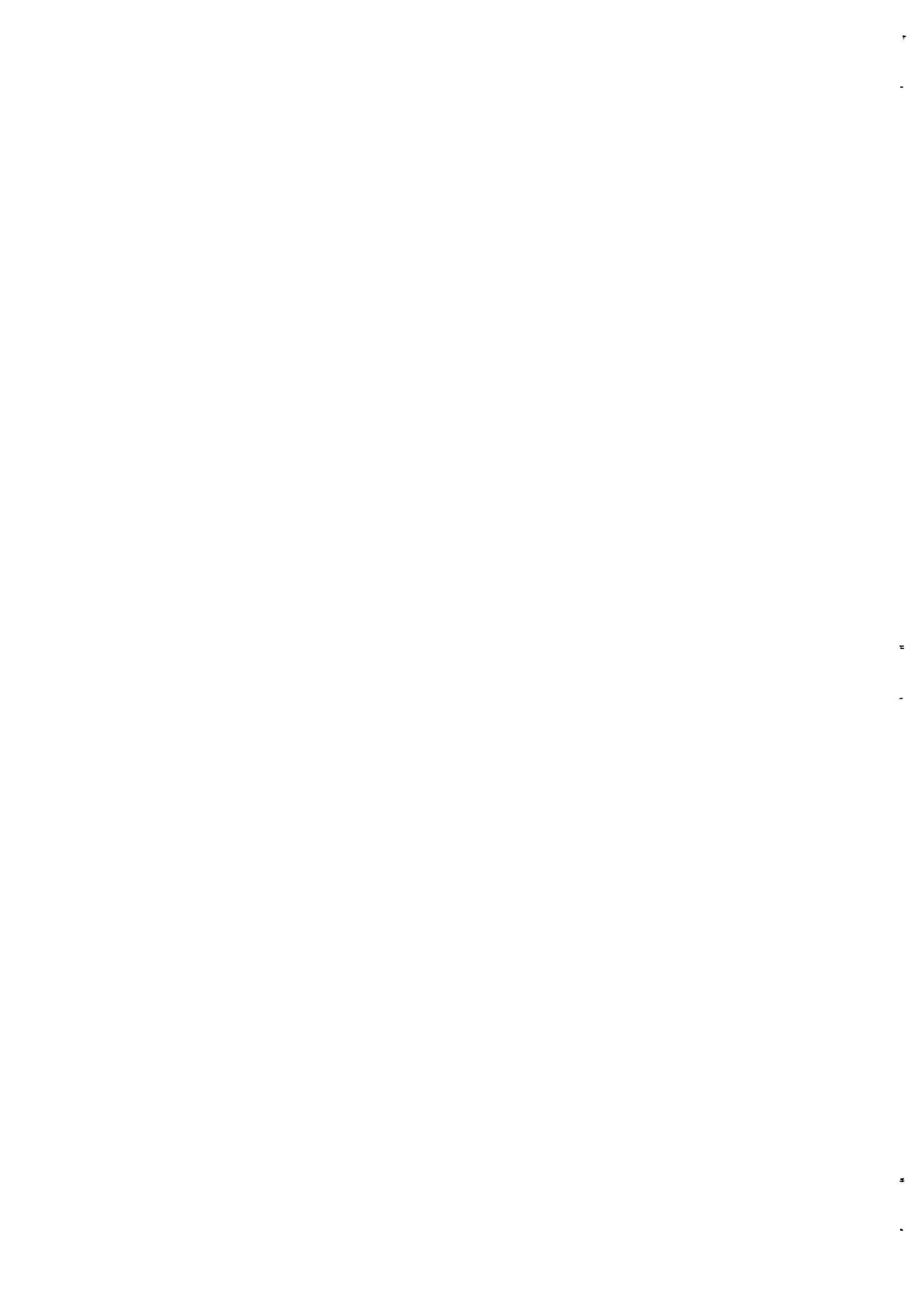

Fig. 4.3  
 Photocopies of  
 chart 1 and  
 chart 2.

( chart 2 : enlarged two times )



A figure as fig. 4.4 reveals a linear relation between wind- and ventilation velocity.

The relation between wind- and ventilation velocity, expressed in the characteristics: regression coefficient and intercept, has been calculated for all the 29 measurements using the least square method. ( Table 4.1)

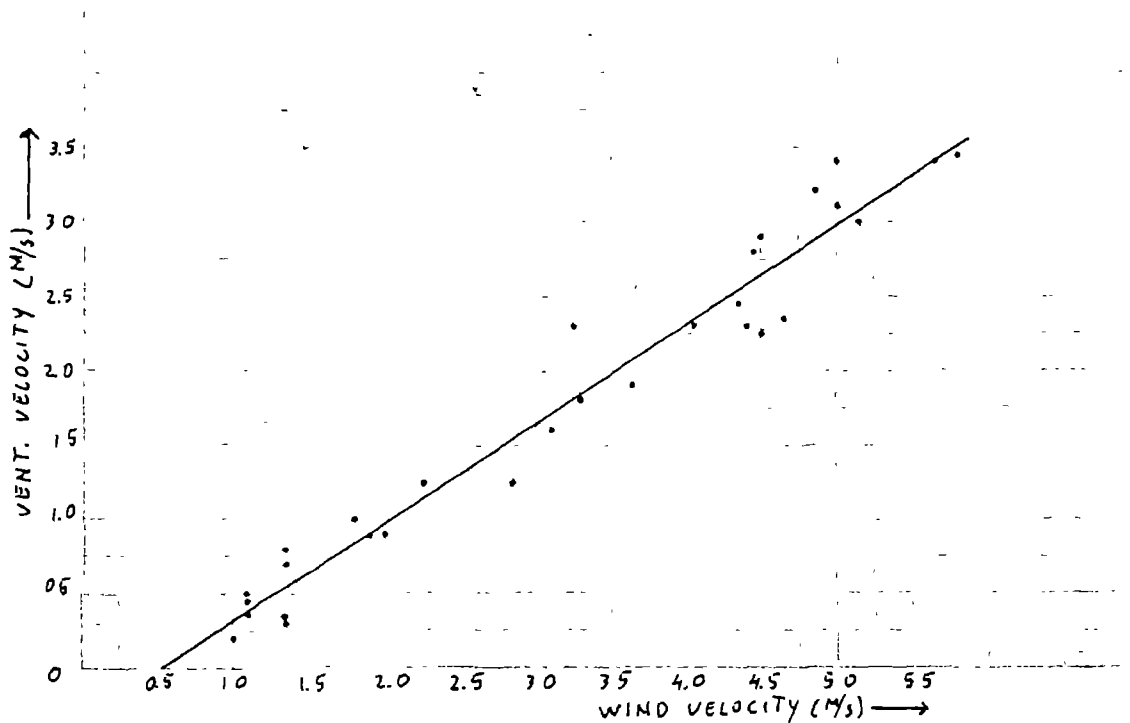

Fig. 4.4 Wind/ventilation velocity relation (measurement A 2)



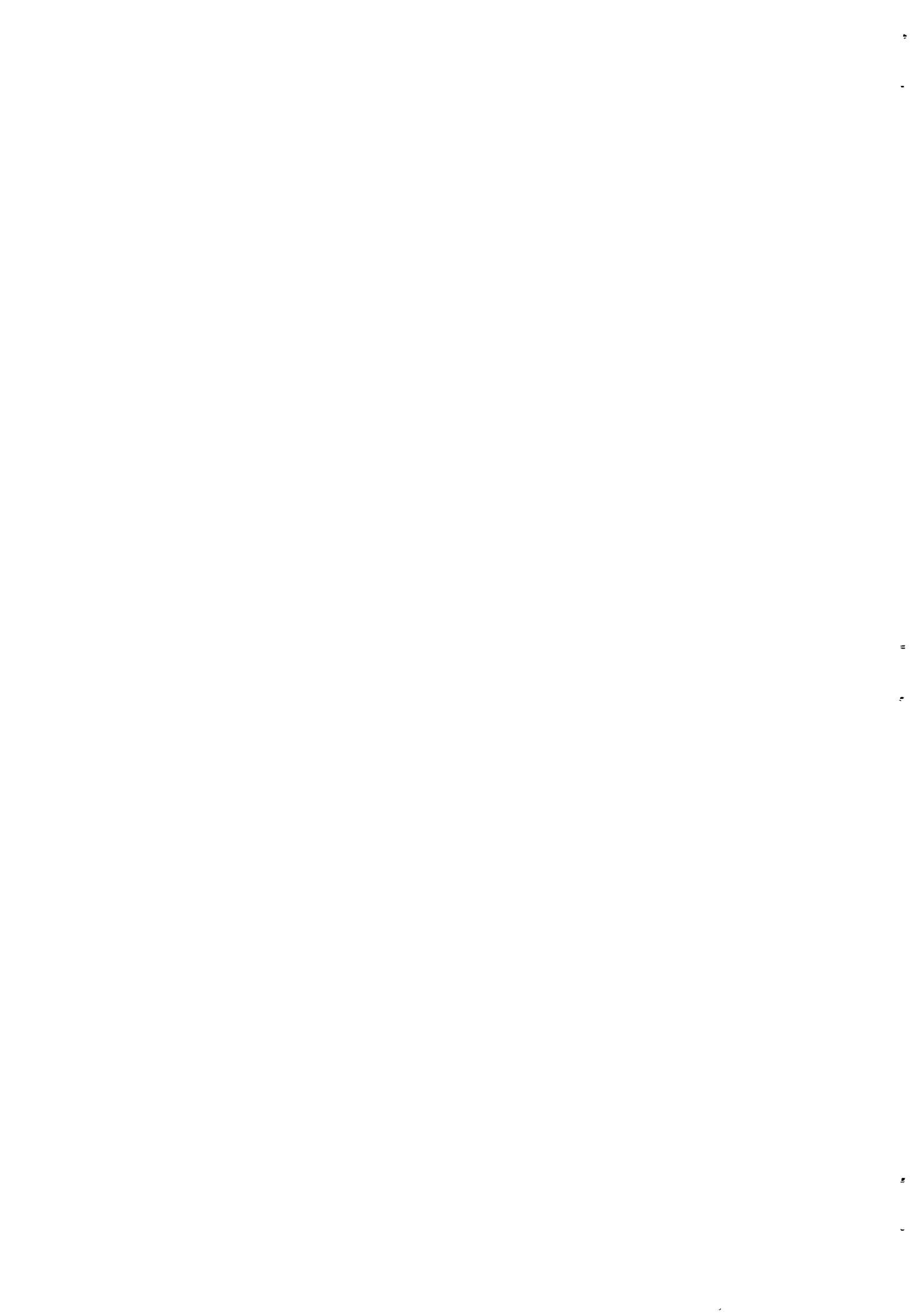

Table 4.1. Results of the least square method (see also appendix 1)  
 $Y = b x + a$   $b$  (-) regression coefficient ventilation (m/s)/wind (m/s)  
 velocity

$a$  (m/s) intercept

The following parameters are calculated after the results of the least square method.

$X_0$  (m/s) minimum wind velocity to create ventilation ( $-a/b$ )

$C$  (m<sup>2</sup>) regression coefficient ventilation volume (m<sup>3</sup>/s)/wind velocity  
 ( $b * \text{area cross-section vent-pipe}$ )

Code	b	a	$X_0$	$C$ ( $*10^{-3}$ )
A 1	0.7051	-0.1350	0.191	10.86
A 2	0.6656	-0.3506	0.527	10.25
A 3	0.6477	-0.3266	0.504	9.97
A 4	0.5961	-0.2926	0.491	9.17
A 5	0.5510	-0.2772	0.503	6.48
A 6	0.5521	-0.2650	0.480	8.50
A 7	0.5964	-0.3770	0.632	9.18
A 8	0.5130	-0.2225	0.434	7.90
A 9	0.5763	-0.2906	0.504	8.87
B 1	0.5856	-0.3698	0.631	5.07
B 2	0.5460	-0.3507	0.642	4.73
B 3	0.6121	-0.3886	0.635	5.30
B 4	0.7921	-0.3903	0.493	6.86
B 5	0.7545	-0.4326	0.573	6.53
B 6	0.6955	-0.5164	0.742	6.02
B 7	0.7241	-0.4941	0.682	11.15
B 8	0.7765	-0.4644	0.598	11.95
B 9	0.7798	-0.3844	0.493	12.00
B 10	0.4498	-0.1685	0.375	16.03
B 11	0.4494	-0.2160	0.481	16.01
B 12	0.4719	-0.3843	0.814	16.81
C 1	0.3214	-0.4889	1.521	4.95
C 2	0.2486	-0.4457	1.793	4.54
C 3	0.4136	-0.6504	1.573	6.37
D 1	0.4800	-0.4935	1.028	4.16
D 2	0.6835	-0.4853	0.710	5.92
D 3	0.4844	-0.3885	0.802	7.46
D 4	0.6566	-0.5075	0.773	10.11
D 5	0.4291	-0.4957	1.155	15.3

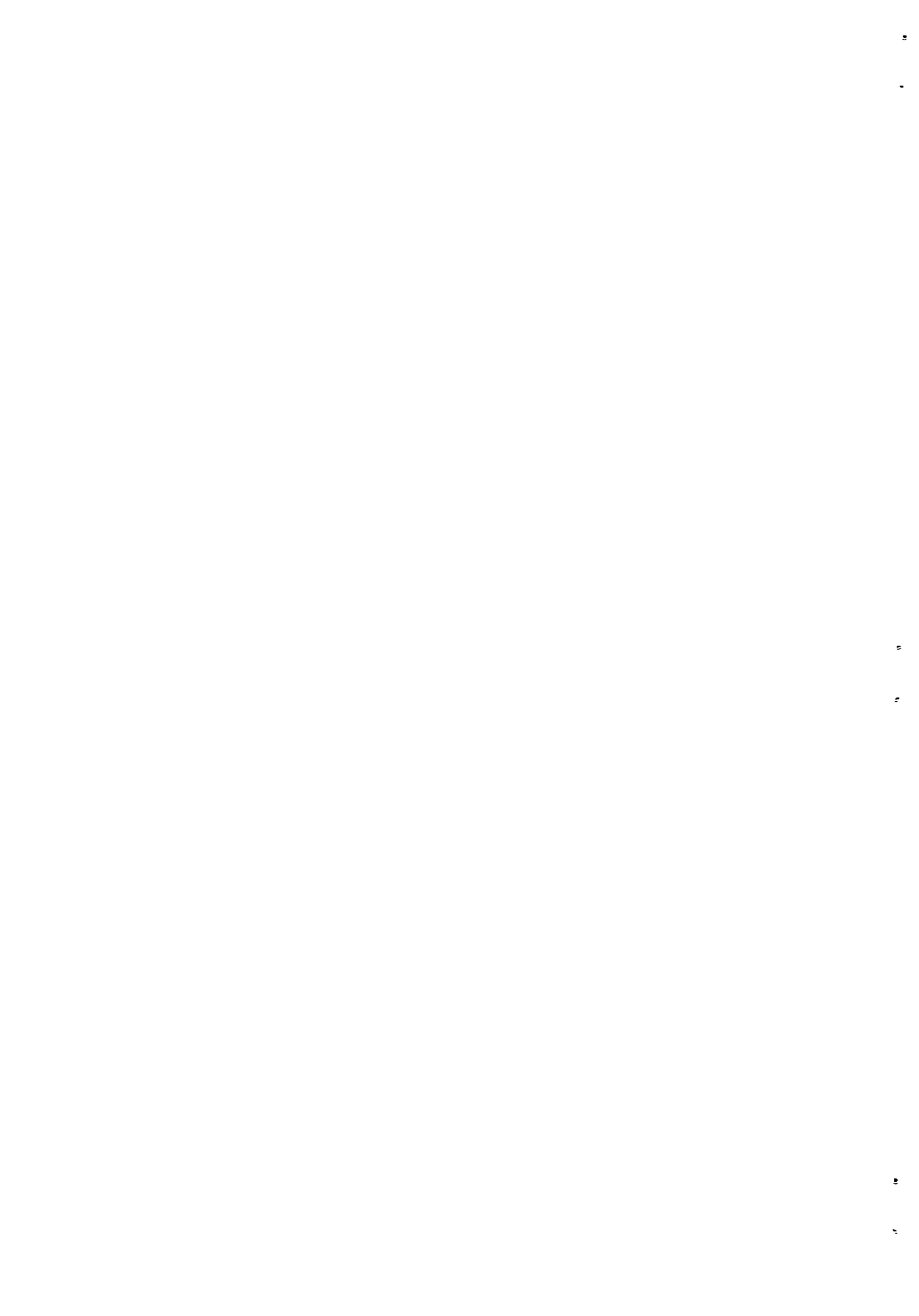
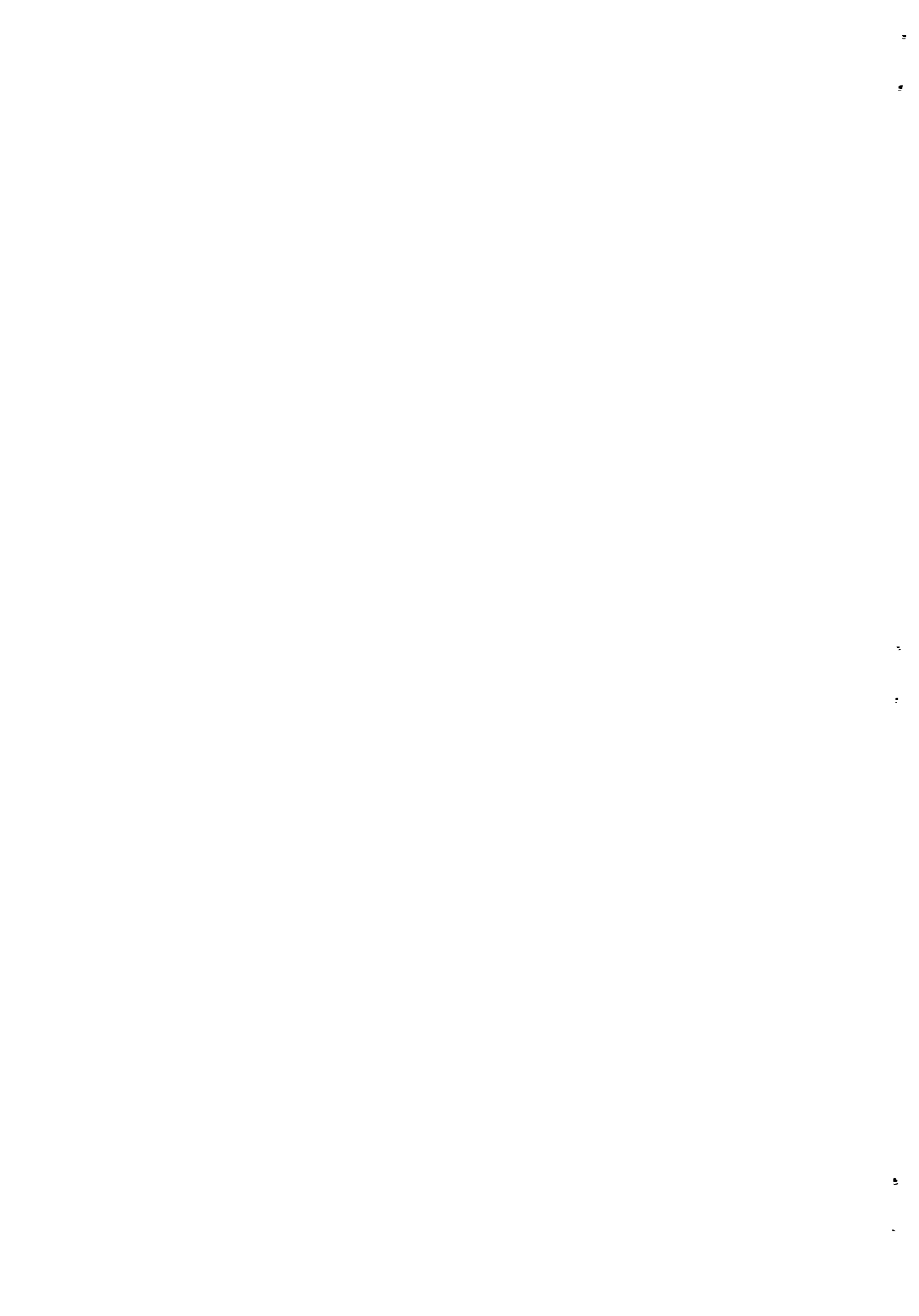

Table 4.2 : For all measurements: duration, max.-med.-min. vent.velocity,  
max.-med.-min. wind velocity, wind stability and wind direction.

Nr:	Length		Vent. Vel. (m/s)			wind vel. (m/s)			wind direct. stability			prevail direct.
	min.	sec.	min.	av.	max.	min.	av.*	max.	bad	reas.	good	
A1	64	58	0	1.2	3.05	0.3	2.1	4.0		x		ne
A2	73	37	0.2	1.7	3.45	1.0	3.1	5.8			x	n
A3	61	1	0.15	1.4	3.6	0.9	2.85	6.25	x			n
A4	71	39	0	1.6	3.05	0.9	3.0	5.65			x	n
A5	65	57	0.10	1.2	2.45	0.6	2.75	4.9			x	n
A6	64	34	0	0.6	1.9	0.25	1.75	3.9	x			s s
A7	87	24	0	1.1	3.7	0.25	2.5	6.8		x		se
A8	63		0	0.9	2.2	0.6	2.3	4.65		x		se
A9	64	10	0.18	1.15	3.2	0.8	2.5	6.55		x		s-se
B1	67	43	0	1.25	2.7	0.30	2.75	5.70			x	e-se
B2	59	51	0	1.10	2.95	0.60	2.80	6.10		x		e
B3	72	26	0	1.35	3.0	0.80	3.0	5.75		x		e
B4	69	17	0.1	2.3	5.0	0.15	3.30	6.95		x		ne
B5	66	56	0	1.6	4.35	0.7	2.80	6.25	x			ne-e
B6	59	51	0	1.1	3.70	0.55	2.25	5.50	x			e
B7	64	10	0	0.85	3.55	0.5	1.8	4.2	x			e-ne
B8	65	45	0	2.0	5.5	0.6	3.4	6.6		x		n-ne
B9	82	41	0	1.4	4.25	0.65	2.5	5.75		x		ne
B10	74	1	0	1.2	3.25	0.8	2.95	6.5			x	n
B11	110	14	0	0.75	2.35	0	2.25	5.95		x		ne
B12	80	19	0	0.62	2.6	0.55	2.4	6.1		x		+ (e-ne) (n-nw)
C1	56	18	0	0.3	1.35	0.6	2.4	5.9		x		s
C2	51	58	0	0.2	1.0	0.55	2.5	5.7		x		w-sw
C3	44	6	0	0.6	1.65	1.1	3.25	5.9		x		s
D1	61	1	0	0.95	2.7	0.75	3.15	6.6		x		e-ne
D2	75	59	0	1.55	3.8	0.6	3.0	6.35		x		ne
D3	74	1	0	0.65	2.55	0.8	2.30	6.1		x		s-sw
D4	91	44	0	1.85	4.2	1.10	2.45	6.6		x		n-ne
D5	81	53	0	0.3	1.75	0.2	1.75	5.0		x		e

\* The average wind velocity during the 29 measurements is 2.59 m/s



#### 4.2 Evaluation of the results

It would be ideal if the ventilation velocity could be described as a function of wind, diameter etc..

Ventilation velocity (m/s) = f (wind, diameter, position, length, mosquito gauze, door, cover)

Hypothetic solution : For position I,II,III, closed door and no cover;

Ventilation velocity<sub>i</sub> (m/s) =  $\alpha$  wind velocity +  $\beta$  diameter + log length +  $\gamma$  porosity<sup>2</sup> mosquito gauze

Due to the limited number of measurements and the lack in knowledge of the theory, it was impossible to find such a solution.

A complete analysis of variance, to test all parameters on significance, could have been possible if all 240 tests had been made. Unfortunately only 29 tests were executed.

#### 4.3 Analysis of variance

##### 4.3.1. Ventilation velocity, diameter

Diameter and position can be tested in a two-way classification.

Remarks:

door not open, no cover, no mosquito gauze, length vent-pipe 2.80m.

Position	I	II	III
Diameter 4"	B1	B2	B3
4" +enl.6"	B4	B5	B6
6"	A3	A6	A9
6" +enl.8"	B7	B8	B9
8"	B10	B11	B12

(B1: code of measurement, see table 3.3)

Table 4.3: code of measurements diameter / position.



Each cell represents a measurement. For the analysis each measurement, each cell, should be represented by one figure.

The regression coefficient (table 4.1) can not be used as representative figure for each measurement, because most relation lines do not cross the X-coordination line in, or near the same point.

Taking the average value of the ventilation velocity would be very inaccurate, due to the fact that the average value of the wind velocity fluctuate reasonably.

This problem can be avoided by dividing the results of the measurements into two groups: I: wind velocity  $\leq 2.5$  m/s

II: wind velocity  $> 2.5$  m/s

A first analysis can be executed by comparing the standard residual deviations. The residual standard deviations are calculated with the least square method.

Mosq.gauze Position	NO I		NO II		NO III		YES II	
	ws $\leq 2.5$	ws $> 2.5$	ws $\leq 2.5$	ws $> 2.5$	ws $\leq 2.5$	ws $> 2.5$	ws $\leq 2.5$	ws $> 2.5$
4"	0.1611	0.2532	0.1354	0.1239	0.1678	0.3004	0.0853	0.1040
4"+enl.6"	0.3131	0.2121	0.1753	0.3527	0.2391	0.5238	0.1273	0.0998
6"	0.2085	0.3431	0.1656	0.1423	0.0903	0.1495	0.2363	0.1212
6"+enl.8"	0.3985	0.8238	0.1370	0.4936	0.1800	0.4158	0.1736	0.3043
8"	0.1601	0.2432	0.1828	0.1388	0.2810	0.3991	0.09838	0.1306

Remarks: no cover, door closed, length vent-pipe 2.80 m

ws = wind speed (m/s)

Table 4.4 : standard deviations linear regression calculations, ws  $\leq 2.5$  m/s  
and ws  $> 2.5$  m/s.

From table 4.4 can be observed that :

- minimum standard deviation 0.0903,
- maximum standard deviation 0.8283.

The spreading in the standard deviation is too big, to use the average value of the ventilation velocity for an analysis of variance. A variance stabilizing transformation is therefore necessary.

- standard deviation  $> 0.30$  can often be found when:

a: an enlarger is used

b: windspeed  $> 2.5$  m/s.

The standard deviations are remarkably low when mosquito gauze is used.





Mosquito gauze has a stabilizing influence on the results of the measurements.

### Variance Stabilizing Transformation

Explanation of the variance stabilizing transformation theory can be found in Ref. 20 (p. 232/238).

Procedure : If  $\bar{y}_i$  = the average value of the ventilation velocity (m/s) in each cell, than  $\bar{z} = \bar{y}^\lambda$  is the transformed average value of the ventilation velocity.

$$\lambda = 1 - \alpha$$

$\alpha$  can empirically be found. (Fig. 4.5, table 4.5)

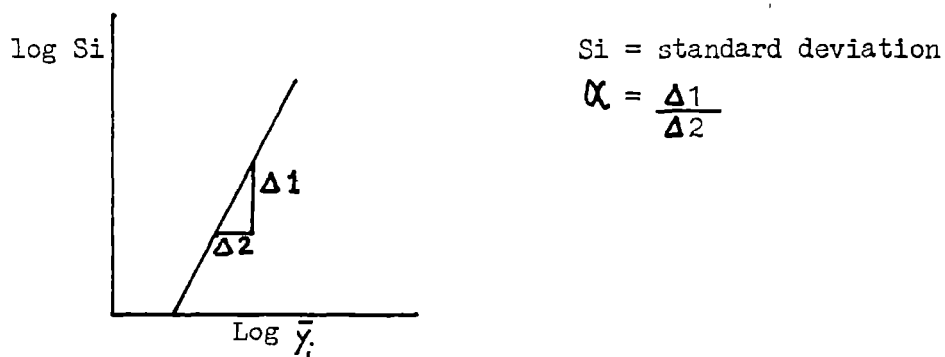

Fig. 4.5 Calculation of variance stabilizing coefficient



Table 4.5 Variance stabilizing transformation

$\bar{Y}_i$  : average value of ventilation velocity (m/s)

$S_i$  : standard deviation

$\bar{Z}_i : \bar{Y}_i^\lambda$

ws : wind speed I  $\leq 2.5$  (m/s) , II  $> 2.5$  (m/s)

Code	ws	$\bar{Y}_i$	$S_i$	$\log \bar{Y}_i$	$\log S_i$	$\bar{Z}_i$
B1	I	0.638	0.1611	-0.195	-0.793	0.849
B1	II	1.633	0.2532	0.213	-0.597	1.461
B2	I	0.562	0.1354	-0.25	-0.868	0.640
B2	II	2.106	0.1239	0.323	-0.907	1.779
B3	I	0.471	0.1678	-0.327	-0.775	0.559
B3	II	2.439	0.3004	0.387	-1.522	1.993
B4	I	1.007	0.3131	0.003	-0.504	1.005
B4	II	2.902	0.2121	0.463	-0.673	2.228
B5	I	0.718	0.1753	-0.144	-0.756	0.774
B5	II	2.821	0.3527	0.450	-0.453	2.230
B6	I	0.52	0.2391	-0.284	-0.621	0.603
B6	II	2.150	0.5238	0.332	-0.281	1.808
A3	I	0.859	0.2085	-0.066	-0.681	0.889
A3	II	2.056	0.3431	0.313	-0.465	1.746
A6	I	0.485	0.1656	-0.314	-0.781	0.571
A6	II	1.425	0.1423	0.154	-0.847	1.315
A9	I	0.411	0.0903	-0.386	-1.044	0.503
A9	II	2.053	0.1495	0.312	-0.825	1.744
B7	I	0.728	0.3985	-0.138	-0.400	0.782
B7	II	1.586	0.8238	0.200	-0.084	1.429
B8	I	0.796	0.1370	-0.099	-0.863	0.838
B8	II	3.058	0.4936	0.485	-0.307	2.374
B9	I	0.609	0.1800	-0.215	-0.745	0.681
B9	II	2.836	0.4158	0.453	-0.381	2.240
B10	I	0.638	0.1601	-0.195	-0.796	0.706
B10	II	1.708	0.2432	0.232	-0.614	1.513
B11	I	0.475	0.1828	-0.323	-0.738	0.562
B11	II	1.595	0.1388	0.203	-0.858	1.435
B12	I	0.486	0.2810	-0.313	-0.551	0.572
B12	II	1.373	0.3991	0.138	-0.399	1.278

$\alpha = 0.2265 \quad \lambda = 0.7735$



Diameter	POSITION I		POSITION II		POSITION III		k = 6
	ws < 2.5 m/s	ws > 2.5 m/s	ws < 2.5 m/s	ws > 2.5 m/s	ws < 2.5 m/s	ws > 2.5 m/s	
4"	0.849	1.461	0.640	1.779	0.559	1.993	1.214
4" + enl. 6"	1.005	2.228	0.774	2.230	0.603	1.808	1.441
6"	0.889	1.746	0.571	1.315	0.503	1.744	1.128
6" + enl. 8"	0.782	1.429	0.838	2.734	0.681	2.24	1.451
n = 5 8"	0.706	1.513	0.562	1.435	0.572	1.278	1.011
	0.846	1.675	0.677	1.899	0.584	1.813	$\bar{Z}=1.249$

Table 4.6 Values of transformed average ventilation velocities  $\bar{Z}$ ; Remarks : no cover  
no mosquito gauze  
door closed  
length vent-pipe 2.80 m

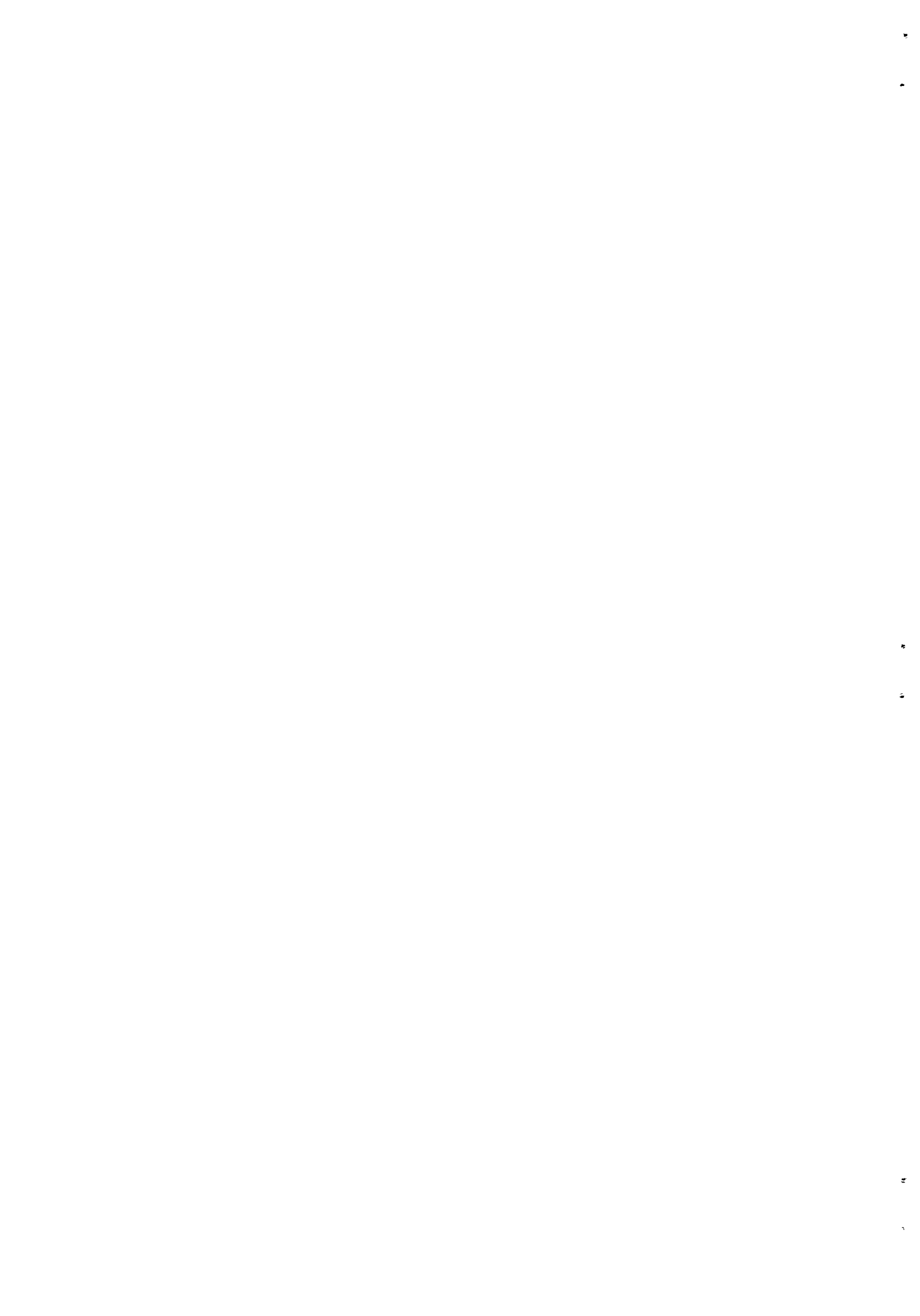

Table 4.7 Analysis of variance table, transformed values of average wind velocity.

source of variation	sum of squares	degrees of freedom	mean square	ratio of mean squares
diameter	$S_b = 0.901$	$n-1 = 4$	$S_b^2 = 0.225$	$S_b^2/S_d^2 = 3.516$
position/ws	$S_c = 9.27$	$k-1 = 5$	$S_c^2 = 1.854$	$S_c^2/S_d^2 = 29$
residuals	$S_d = 1.272$	$(n-1)(k-1) = 20$	$S_d^2 = 0.064$	
Total	$S = 11.44$	$N-1 = 29$		

With information of table 4.7, the following can be revealed.

The F-test indicates that the influence of position/wind speed is absolutely significant. This could be expected as a result of the division of wind speed into two groups.

The most important conclusion, however, is that the influence of the diameter on ventilation velocity is not significant ( $F_{0.05} (5/20) = 4.76$ ) within the limits of accuracy of this research.

4.3.2 ventilation volume ( $m^3/s$ ), diameter

Ventilation volume calculated as :

ventilation velocity \* Area of cross-section vent-pipe.

(Flow characteristics, turbulent)

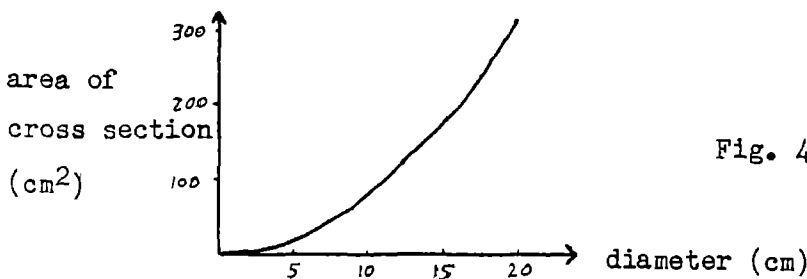

Fig. 4.6: diameter/area of cross-section

An analysis of variance is applied on ventilation volume, position/wind speed.



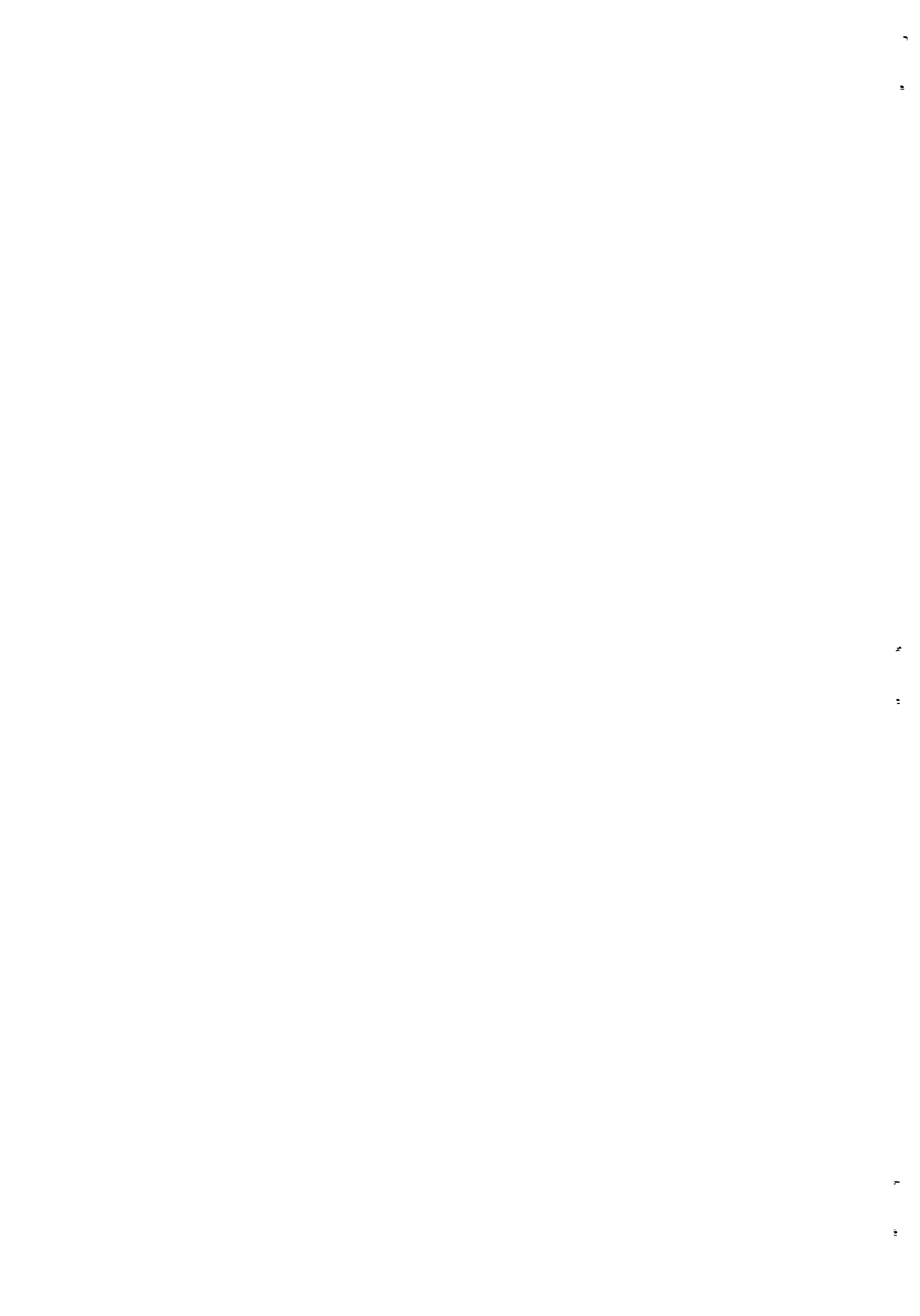

Table 4.8 Variance stabilizing transformation, ventilation volume.

Code	ws	$\bar{Y}_i' = (\bar{Y}_i * A)$	$S_i' = (S_i * A)$	$\text{Log}(\bar{Y}_i' \cdot 10^3)$	$\text{Log}(S_i' \cdot 10^3)$	$\bar{Z}_i'$
B1	I	$5.52 \cdot 10^{-3}$	$1.39 \cdot 10^{-3}$	0.74	0.14	1.98
B1	II	14.14	2.19	1.15	0.34	2.89
B2	I	4.87	1.17	0.69	0.07	1.88
B2	II	18.24	1.07	1.26	0.03	3.19
B3	I	4.08	1.45	0.61	0.16	1.75
B3	II	21.12	2.60	1.32	0.41	3.39
B4	I	8.72	2.71	0.94	0.43	2.38
B4	II	25.13	1.84	1.40	0.26	3.63
B5	I	6.22	1.52	0.79	0.18	2.08
B5	II	24.43	3.05	1.39	0.48	3.59
B6	I	4.50	2.07	0.65	0.32	1.83
B6	II	18.62	4.54	1.27	0.66	3.22
A3	I	13.22	3.21	1.12	0.51	2.81
A3	II	31.65	5.28	1.50	0.72	3.98
A6	I	7.47	2.55	0.87	0.41	2.24
A6	II	21.94	2.19	1.34	0.34	3.44
A9	I	6.33	1.39	0.80	0.14	2.09
A9	II	31.6	2.30	1.50	0.36	3.98
B7	I	11.21	6.13	1.05	0.79	2.63
B7	II	24.41	5.05	1.39	0.70	3.59
B8	I	12.25	2.11	1.09	0.32	2.72
B8	II	47.07	7.60	1.67	0.88	4.67
B9	I	9.37	2.77	0.97	0.44	2.45
B9	II	43.65	6.40	1.64	0.81	4.53
B10	I	22.73	5.72	1.36	0.76	3.49
B10	II	60.86	8.67	1.78	0.94	5.17
B11	I	16.93	6.51	1.23	0.81	3.10
B11	II	56.83	4.95	1.75	0.69	5.03
B12	I	17.32	10.01	1.24	1.00	3.13
B12	II	48.92	14.22	1.69	1.15	4.74

Remarks :  $\bar{Y}_i' = \bar{Y}_i * A$  : ventil. volume ( $10^{-3} \frac{m^3}{s}$ )  
 $S_i' = S_i * A$  standard deviation  
 $Z_i' = \frac{\bar{Y}_i' - \lambda}{\alpha}$  stabilized value of  $\bar{Y}_i'$   
 $\lambda = 1 - \alpha$   $\alpha = 0.60$

B1 / B6  $A = 3.66 \cdot 10^{-3} m^2$   
A3 / A9 and B7 / B9  $A = 15.39 \cdot 10^{-3} m^2$   
B10/B12  $A = 35.63 \cdot 10^{-3} m^2$



DIAMETER	POSITION I		POSITION II		POSITION III K=6		
	ws 2.5 m/s	ws 2.5 m/s	ws 2.5 m/s	ws 2.5 m/s	ws 2.5 m/s	ws 2.5 m/s	
4"	1.98	2.89	1.88	3.19	1.75	3.39	2.51
4" +enl.6"	2.38	3.63	2.08	3.59	1.83	3.22	2.79
6"	2.81	3.98	2.24	3.44	2.09	3.98	3.09
6" +enl.8"	2.63	3.59	2.72	4.67	2.45	4.53	3.43
n = 5 8"	3.49	5.17	3.10	5.03	3.13	4.74	4.11
	2.66	3.85	2.40	3.98	2.25	3.97	$\bar{Z}_i = 3.19$

Table 4.9 Analysis of variance transformed values of ventilation volume.  $\bar{Z}_i$

Remarks : No mosquito gauze  
No cover  
Pipe length, 2.80 (m)



Table 4.10 Analysis of variance table, transformed average values of ventilation volume.

source of variation	sum of squares	degrees of freedom	mean square	ratio of mean squares
diameter	$S_b = 9.22$	$n-1 = 4$	$S_b^2 = 2.31$	$S_b^2/S_d^2 = 29.6$
position/ws	$S_c = 17.28$	$k-1 = 5$	$S_c^2 = 3.46$	$S_c^2/S_d^2 = 44.4$
residuals	$S_d = 1.56$	$(n-1)(k-1) = 20$	$S_d^2 = 0.078$	
total	$S = 28.06$	$N-1 = 29$		

$$F_{0.005}(4/20) = 5.17$$

$$F_{0.005}(5/20) = 4.76$$

Table 4.10 shows obviously that the influence of diameter on ventilation volume is significant. The ratio of mean squares ( $F_{0.005}(4/20) = 5.17$ )  $S_b^2/S_d^2 = 29.6$  exceeds enormously the 0.5% significance level.

The high ratio of mean squares for position/ws can be explained by the division of the wind velocity into two groups.



4.3.3 Quantification of influence of diameter on ventilation volume.

In table 4.11 the ventilation velocity / wind velocity relation is transformed by multiplying with the area of cross-section concerned, to a ventilation volume/ wind velocity relation.

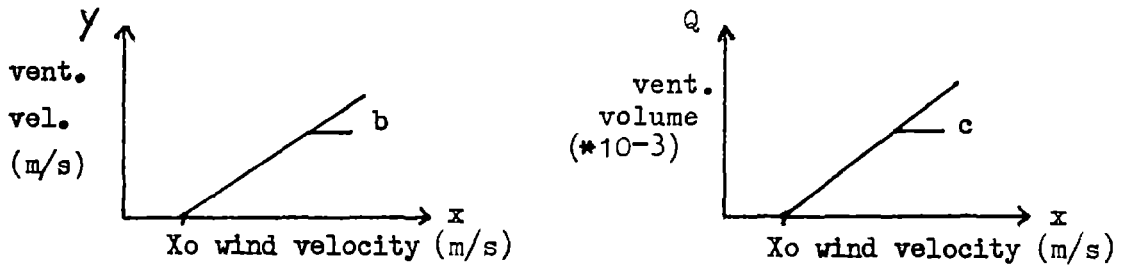

Diameter	Code	X <sub>0</sub>	b	C*10 <sup>-3</sup>	Q (m <sup>3</sup> /s) for a wind speed of (*10 <sup>-3</sup> ) 2.59 m/s
4"	B1	0.631	0.5856	5.071	9.93
4"	B2	0.642	0.5460	4.728	9.21
4"	B3	0.635	0.6121	5.300	10.36
4"+6"enl.	B4	0.493	0.7921	6.859	14.38
4"+6"enl.	B5	0.573	0.7545	6.533	13.18
4"+6"enl.	B6	0.742	0.6955	6.023	11.13
6"	A3	0.504	0.6477	9.971	20.8
6"	A6	0.480	0.5521	8.499	17.93
6"	A9	0.504	0.5763	8.872	18.51
6"+8"enl.	B7	0.682	0.7241	11.147	21.27
6"+8"enl.	B8	0.598	0.7765	11.953	23.81
6"+8"enl.	B9	0.493	0.7798	12.004	25.17
8"	B10	0.375	0.4498	16.027	35.50
8"	B11	0.481	0.4424	16.013	33.77
8"	B12	0.481	0.4719	16.815	35.46

Table 4.11 Results diameter.



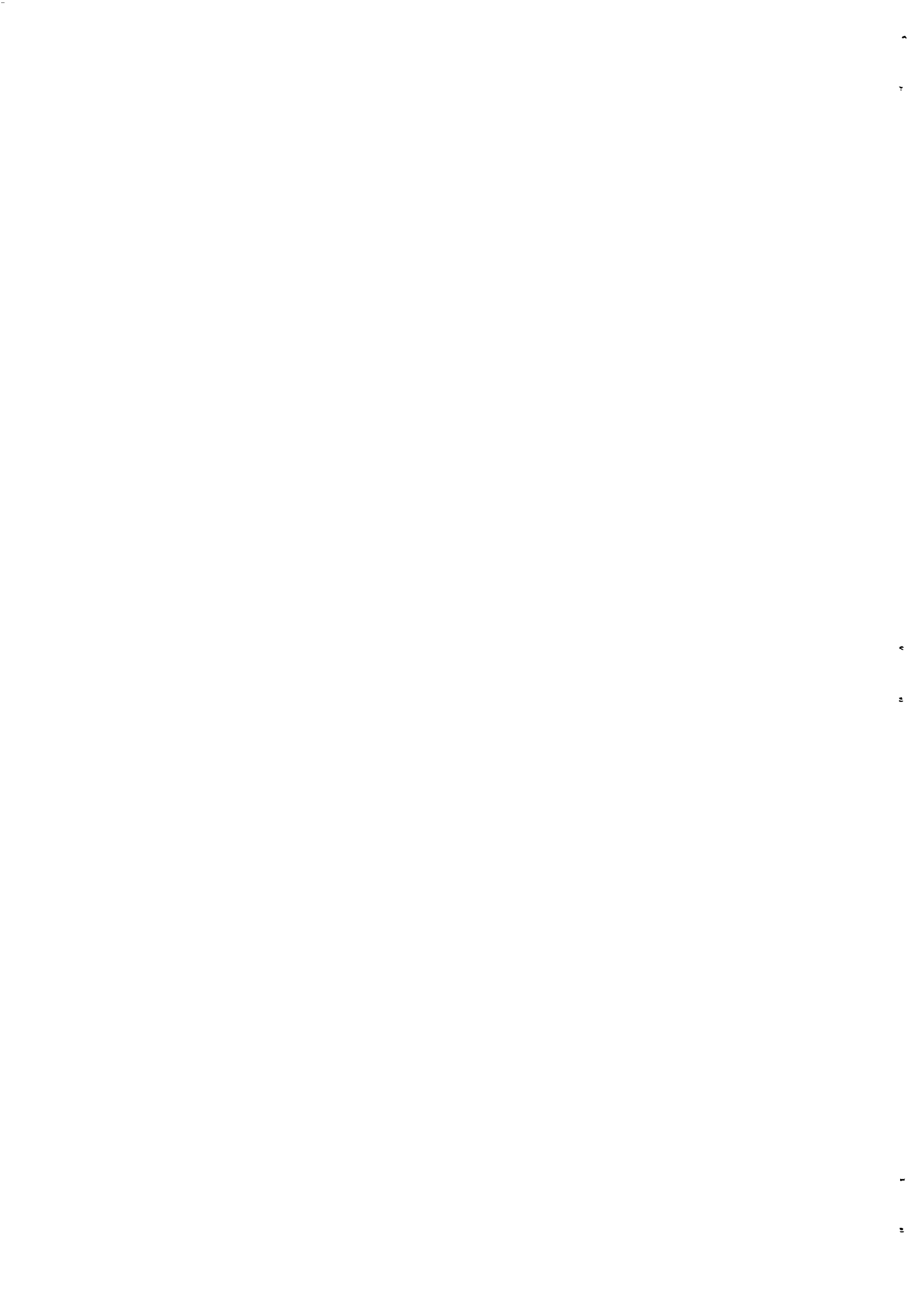

Comparing the different values of c, ignoring the different values of x, we see that;

Diameter / enlarger

Both, diameter and enlarger, are significant parameters.

a 6" enlarger put on a 4" pipe will increase efficiency with +29%

a 8" enlarger put on a 6" pipe will increase efficiency with +28%

The respective figures in percentages of regression coefficient C for the vent. pipes with/without enlargers are:

4"	55%
4" + 6" enl.	71
6"	100
6" + 8" enl.	128
8"	178

Roughly can be stated, that these figures can be applied also on ventilation volumes ( $m^3/s$ ).

4.4 Mosquito gauze

The influence of mosquito gauze on ventilation has been tested on the five different diameters.

The mosquito gauze used, is from Fothersgill & Harvey Ltd. U.K.;

No. of threads/cm: 7.0 in one direction and  
5.5 in the other

Thread diameter : 0.25 mm

per square cm,  $0.288 \text{ cm}^2$  is covered by mosquito gauze.

The reduction in ventilation volume, due to the influence of mosquito gauze is significant. (Table 4.11).

The average values of the ventilation velocities are transformed as in table 4.5. The results are compared to the transformed values of the ventilation volumes, of the identical tests without mosquito gauze, minus two times the standard deviation. (0.078).



Code	Diam.	ws	$\bar{Y}$ (m/s)	s.d.	$\bar{Y}' \cdot 10^{-3}$ (m <sup>3</sup> /s)	$\bar{Z}' = \bar{Y}'^{0.4}$	Code	$Z_i' - ,166$ (table 4.8)
D1	4"	I	0.296	0.0853	2.56	1.46	B2	1.72
		II	1.503	0.104	13.06	2.79		3.03
D2	4"+6"enl.	I	0.427	0.1273	3.70	1.69	B5	1.92
		II	2.784	0.0998	24.11	3.57		4.43
D3	6"	I	0.338	0.2363	5.20	1.93	A6	2.08
		II	1.650	0.1212	25.4	3.65		3.28
D4	6"+8"enl.	I	0.773	0.1736	11.90	2.69	B8	2.56
		II	2.553	0.3043	39.30	4.37		4.51
D5	8"	I	0.321	0.0984	11.44	2.65	B11	2.94
		II	0.900	0.1306	32.07	4.00		4.87

Table 4.12 Mosquito gauze significance testing

In eight out of ten times,  $Z_i' < (Z_i' - 0.166)$

However, it is difficult to say exactly, in figures, how much reduction in ventilation volume is caused by the use of mosquito gauze.

An attempt is made in table 4.13.

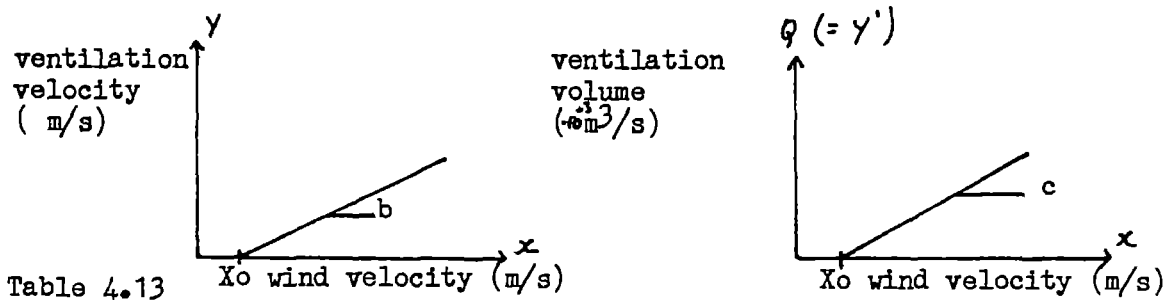

Table 4.13

Code	Diameter	Xo	ΔXo	b	S(b)	c(10 <sup>-3</sup> )	Q* (10 <sup>-3</sup> m <sup>3</sup> /s)	
B2	4"	0.642		0.5460	0.015	4.728	9.21	
D1		1.028	0.39	0.4800	0.012	4.156	6.49	-30%
B5	4"+6"enl.	0.573		0.7545	0.035	6.533	13.18	
D2		0.710	0.14	0.6835	0.011	5.918	11.13	-16%
A6	6"	0.480		0.5521	0.027	8.499	17.93	
D3		0.802	0.32	0.4844	0.012	7.457	13.33	-26%
B8	6"+8"enl.	0.598		0.7765	0.023	11.953	23.81	
D4		0.773	0.18	0.6566	0.026	10.108	18.37	-23%
B11	8"	0.481		0.4494	0.021	16.013	33.77	
D5		1.155	0.67	0.4291	0.023	15.290	21.94	-35%

\* ws = 2.59 (m/s)



Remarks :  $X_0$  minimum wind velocity required to create ventilation  
 b regression coefficient vent.velocity/wind velocity  
 S(b) standard deviation regression coefficient.  
 c regression coefficient vent.volume/wind velocity  
 Q ventilation volume ( $m^3/s$ ), wind velocity is 2.59 m/s.  
 2.59 m/s is the average wind velocity during the 29 measurements.

The minimum wind velocity to create ventilation is increased by the application of mosquito gauze on the top of a vent-pipe. The average increase is 0.34 m/s.

The average reduction in ventilation volume for a wind velocity of 2.59 m/s is 26%.

Both  $X_0$  and the reduction in ventilation volume vary reasonably. Therefore, the figures of 0.34 m/s and 26% should be seen as indications.

#### 4.5 Cover

The results of the two tests, C1 and C2, reveal a significant influence on ventilation efficiency, due to the use of a cover on :

- $X_0$  minimum wind speed required to create ventilation
- b regression coefficient ventilation/wind velocity
- c regression coefficient ventilation volume/wind velocity.

Code characteristics	$X_0$	b	S(b)	$C \times 10^{-3}$	Vent.velocity (m/s) for $w_s$ 2.59 m/s.
A6 reference	0.480	0.5521	0.027	8.50	1.165 100%
D3 mosquito gauze	1.028	0.4844	0.013	7.46	0.866 74%
C1 cover on key hole	1.521	0.3210	0.017	4.95	0.344 30%
C2 cover on key hole + mosquito gauze	1.793	0.2486	0.027	4.54	0.198 17%

Table 4.14 Results Cover

Remarks: 6" vent-pipe, position II, length 2.80 m.

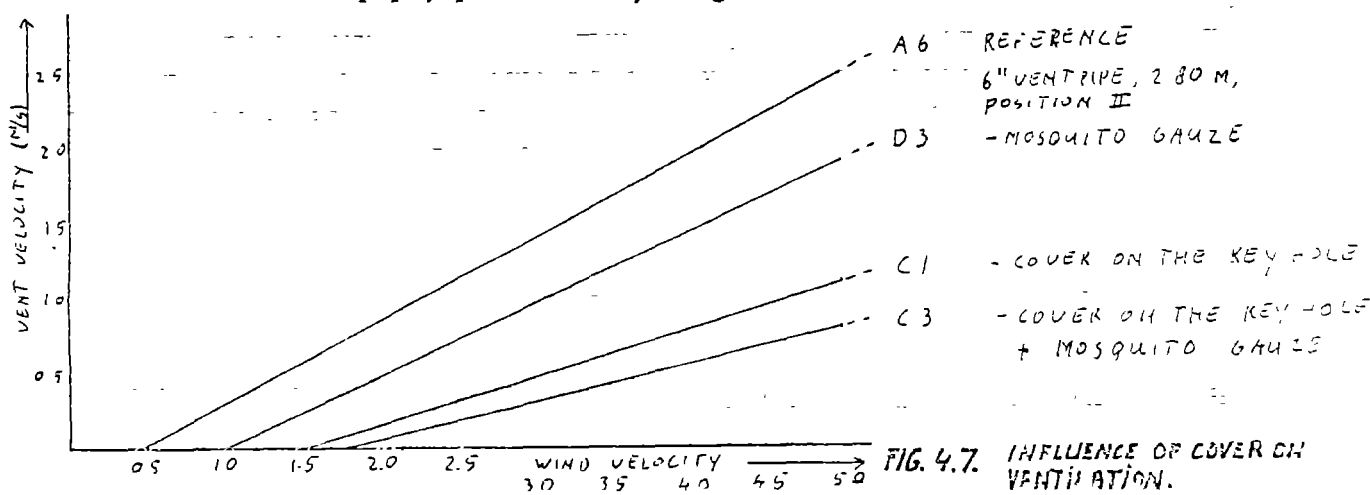



The use of a cover reduces ventilation efficiency to 30%, in relation to an open vent-pipe.

The combination of mosquito gauze + cover has a disastrous impact on ventilation. The minimum wind speed required to create ventilation is 1.79 m/s, while the regression coefficient  $b$  drops to 0.25.

#### 4.6 Position /Length vent-pipe

The results of the measurements expressed in intercept and regression coefficient (table 4.1, fig.4.8) reveal as favourable combination : the shortest pipe of 2.40 m on position I.

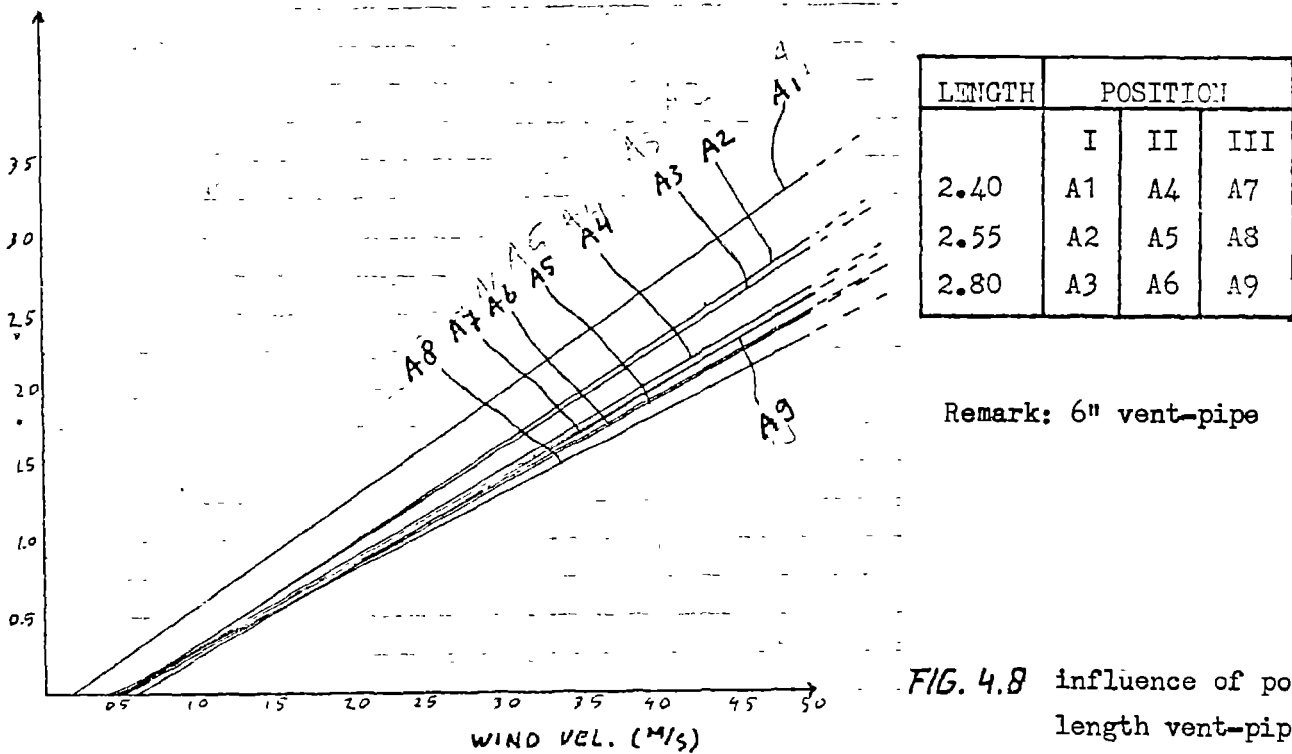

FIG. 4.8 influence of position/length vent-pipe

Although this positive effect is explainable (Chapter 3.4), the reliability of measurement A1 is low.

A 95% reliability interval around the wind/ventilation velocity relation includes all the other measurements.

The conclusion must be that position or length does not influence ventilation efficiency significantly.





#### 4.7      Open/closed door

The effect of cross-ventilation is more experienced with an open door.

The only measurement executed with an open door shows the following results.

- The minimum wind velocity  $X_0$  required is ± 1.6 m/s
- The regression coefficient  $c$ , representing the linear relation between ventilation volume and wind velocity, drops to 0.4136.



## - Mechanism of ventilation

This study finds a linear relation between wind velocity and ventilation velocity.

Wind blowing over a vent-pipe creates an under-pressure. Due to the difference in pressure pit/top vent-pipe, ventilation will take place.

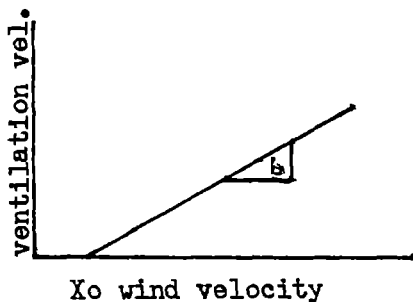

$X_0$  Minimum wind speed required to create ventilation

$$b = \frac{\Delta \text{ventilation velocity}}{\Delta \text{wind velocity}}$$

Fig. 5.1 Wind/ventilation velocity relation.

A minimum wind velocity ( $X_0$ ) is required to create ventilation. When the wind velocity exceeds  $X_0$ , a linear relation between wind/ventilation is established.

The most important conclusion is that a VIP latrine needs wind to create ventilation.  $X_0$  and the coefficient  $a$  depend on a number of parameters, such as diameter vent-pipe, design of superstructure etc.

## - Standard

The required ventilation volume is not defined, see chapter 2.3.

To my opinion, an air change of the superstructure every five minutes will quarentee that odour inside the superstructure after use will be sufficiently removed. A contineous air flow ensures that odours from the pit won't enter the superstructure. The volume of the VIP superstructure is  $2.1 \text{ m}^3$ .

A volume flow of  $25 \text{ m}^3/\text{h}$  ( $6.94 \cdot 10^{-3} \text{ m}^3/\text{s}$ ) satisfies, not considering the positive effect of cross-ventilation.

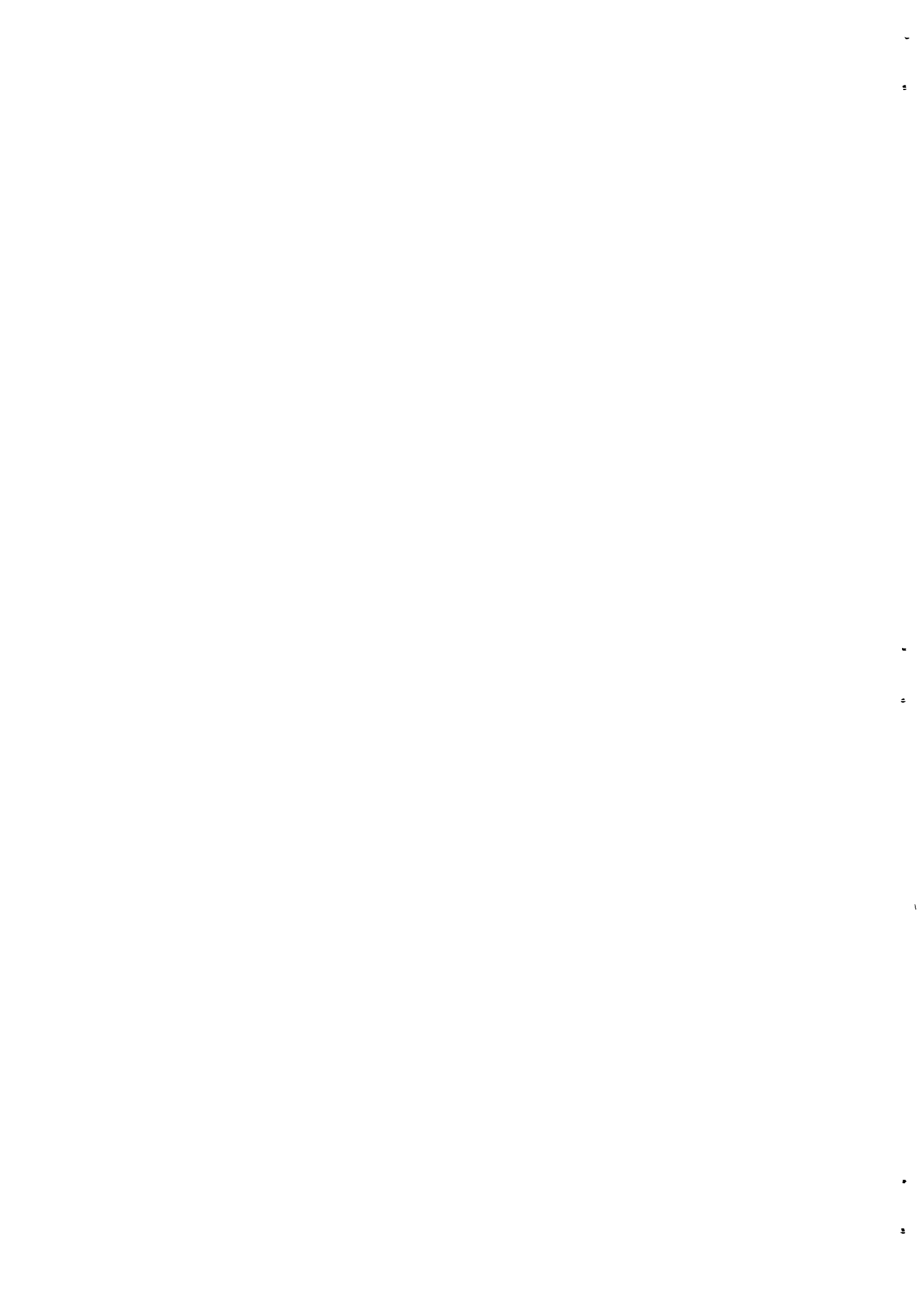

- Diameter of vent-pipe, the use of enlargers.

The following types were selected :

- 4" diameter
- 4" diameter + 6" enlarger
- 6" diameter
- 6" diameter + 8" enlarger
- 8" diameter

The influence of diameter/enlarger could not be statistically proved. Ventilation volume ( $m^3/s$ ), induced by wind, is significantly depending on diameter/enlarger.

Roughly can be stated :

'Diameter'	4"	4"+6"enl.	6"	6"+8"enl.	8"
Vent. efficiency	55%	71%	100%	128%	178%

More interesting is the question of which diameter should be used. The answer depends on the wind situation. In a windy area a 4" or a 4"+6" enl. will meet the needs.

On a location where not much wind is experienced, a 6"; 6"+ 8"enl. or even a 8" diameter vent-pipe should be fixed. However, when the average wind velocity is less than 1 m/s, the ventilation as described in this report does not function properly.

- Mosquito gauze

The mosquito gauze used, is from Fothergill & Harvey Ltd. U.K.

Numbers of threads/cm: 7.0 in one direction  
5.5 in the other

Thread diameter : 0.25 mm

The use of mosquito gauze reduces ventilation efficiency.

- Xo the minimum wind speed required to create ventilation is increased (roughly  $\pm 0.35$  m/s)
- c the regression coefficient ventilation volume/wind velocity is decreased.



The reduction in ventilation volume for a wind speed of 2.59 m/s, the over-all average ventilation velocity during the measurements, is approximately 25%.

Mosquito gauze is essential for proper functioning of a VIP latrine. The reduction in ventilation efficiency should therefore be kept in mind before choosing the type of vent-pipe.

#### - Cover

The function of a cover is to prevent flies and mosquitos from entering and leaving the pit.

With regard to ventilation, a cover is a severe obstacle to flow. The combination of mosquito gauze + cover is fatal for ventilation. The minimum wind velocity, before ventilation starts working, is appr. 1.8 m/s. A cover should therefore not be used. However, when the superstructure is not able to ensure relative darkness, hence flies prefer to leave the pit through the squatting slab instead of through the vent-pipe, then a cover has to be used.

#### - Position/length vent-pipe

The Dar es Salaam type of VIP latrine has installed the vent-pipe inside the superstructure of the latrine. Three positions and three different pipe lengths were selected.

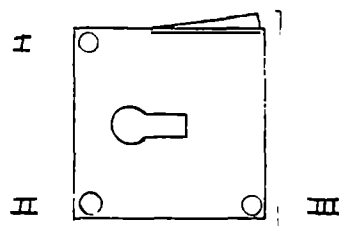

No influence of these parameters on ventilation could statistically be proved. However, the top of the vent-pipe should reach at least the highest point of the roof. Using the minimum lengths mentioned here above, than the most preferable position is where the top of the vent-pipe is located near the top of the roof. This will avoid a positive wind gradient and hence wind blowing into the top of the vent-pipe reducing ventilation efficiency. The positive gradient might be induced by the slope of the roof. The length of the vent-pipe might even be increased when f.i. the latrine is located in between two houses.





Results of least square method and statistical information for each measurement seperately.

Each page gives for one measurement the following information :

- b regression coefficient
- a intercept
- R correlation coefficient
- S(y,x) residual standard deviation
- S(a) standard deviation intercept
- S(b) standard deviation regression coefficient b
- t test for intercept a; (N-2) degrees of freedom
- t test for regression coefficient b; (N-2) degrees of freedom
- SS(y) total summ of squares; (N-1) degrees of freedom
- SS(reg) summ of squares ascribed to regression-equation
- SS(res) summ of squares ascribed to deviations of regression-equation; (N-2) degrees of freedom
- n number of points concerned

Table 3.3 Survey test programme, explanes codes used.

Door open	NO											YES			
Cover	NO											YES	YES	NO	
Mosquito gauze	NO											YES	NO	YES	NO
Position	I			II			III			II	II	II	II		
Length	a	b	c	a	b	c	a	b	c	c	c	c	c		
Diameter 4"	-	-	B1	-	-	B2	-	-	B3	D1	-	-	-		
4"+enl. 6"	-	-	B4	-	-	B5	-	-	B6	D2	-	-	-		
6"	A1	A2	A3	A4	A5	A6	A7	A8	A9	D3	C1	C2	C3		
6"+enl. 8"	-	-	B7	-	-	B8	-	-	B9	D4	-	-	-		
8"	-	-	B10	-	-	B11	-	-	B12	D5	-	-	-		

Table: 3.3 survey test programme

a: 2.40 m b: 2.55m c: 2.80m

-: not covered

A6: code of specific test

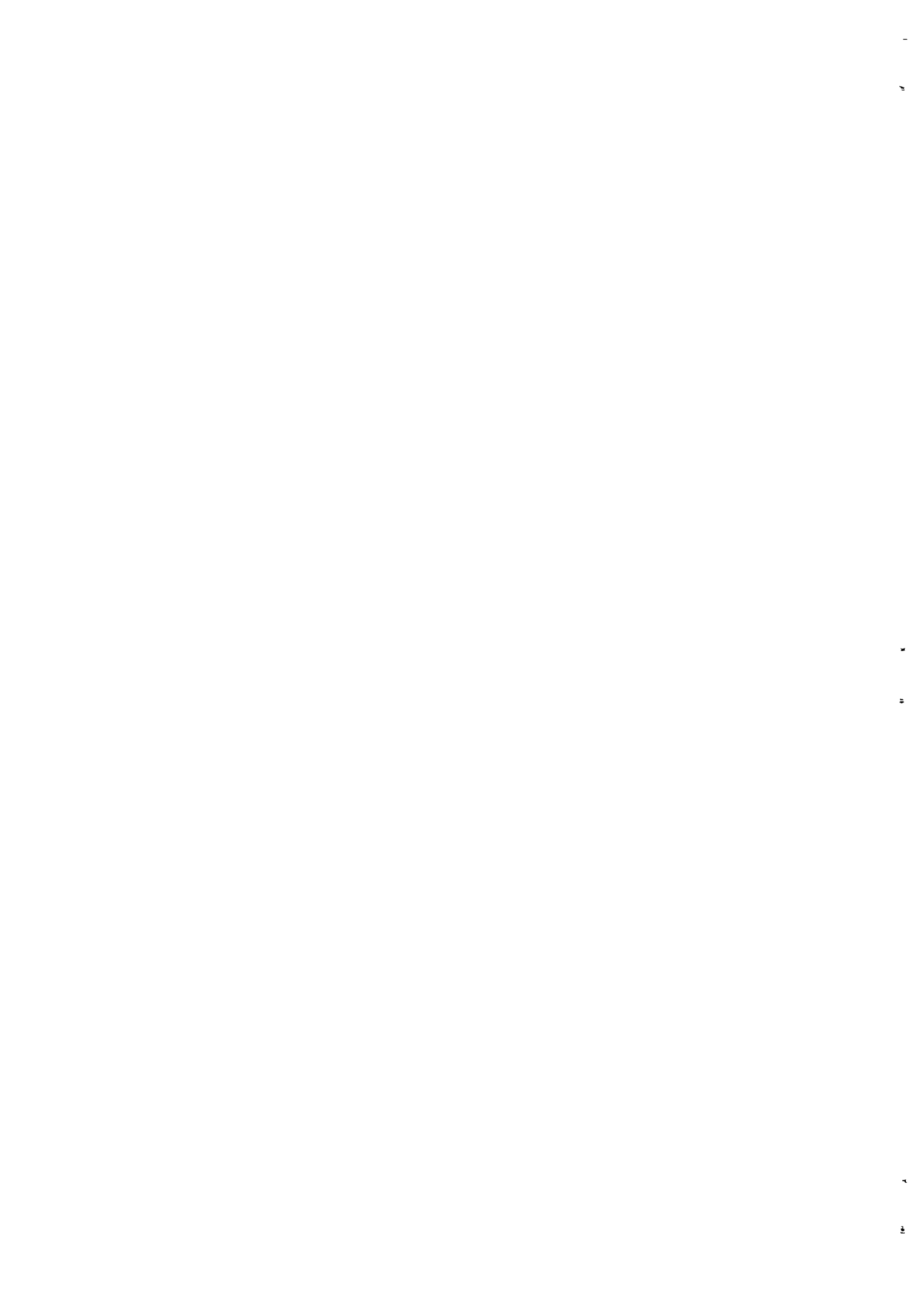

$$Y=bX+a$$

$$b= 0.7051E+00$$

$$a=-0.1350E+00$$

de correlatiecoefficient	R= 0.8837E+00
de residuele standaardafwijking	S(y,x)= 0.4080E+00
de standaardfout in het intercept	S(a)= 0.1475E+00
de standaardfout in res.coefficient b:	S(b)= 0.6934E-01
toetsins voor het intercept a,	
met (N-2) vrijheidsgraden	t= 0.9156E+00
toetsins voor repressiecoefficient b	
met (N-2) vrijheidsgraden	t= 0.1017E+02
de totale Kwadraatsom	
met (N-1) vrijheidsgraden	SS(y)= 0.2205E+02
de kwadraatsom, toe te schrijven	
aan de repressievergelijking	SS(res)= 0.1722E+02
de kwadraatsom, toe te schrijven	
aan afwijkingen van de repressie-	
vergelijking met (N-2) vrijh.grad.	SS(res)= 0.4829E+01

De ingevoerde punten zijn:

n	X-waarde	Y-waarde
1	0.900	0.550
2	2.950	1.800
3	0.850	0.400
4	1.350	0.900
5	3.450	2.450
6	0.950	0.350
7	1.700	1.150
8	3.050	2.500
9	0.002	1.700
10	0.700	0.100
11	2.200	1.250
12	0.850	0.000
13	0.950	0.100
14	3.650	2.400
15	0.650	0.000
16	1.750	0.950
17	0.650	0.250
18	1.750	1.200
19	1.600	1.100
20	2.450	1.400
21	2.850	1.700
22	0.600	0.100
23	2.550	1.700
24	0.750	0.250
25	2.350	1.250
26	2.550	1.600
27	0.900	0.250
28	2.350	1.800
29	2.900	1.950
30	4.000	3.050
31	3.000	1.950

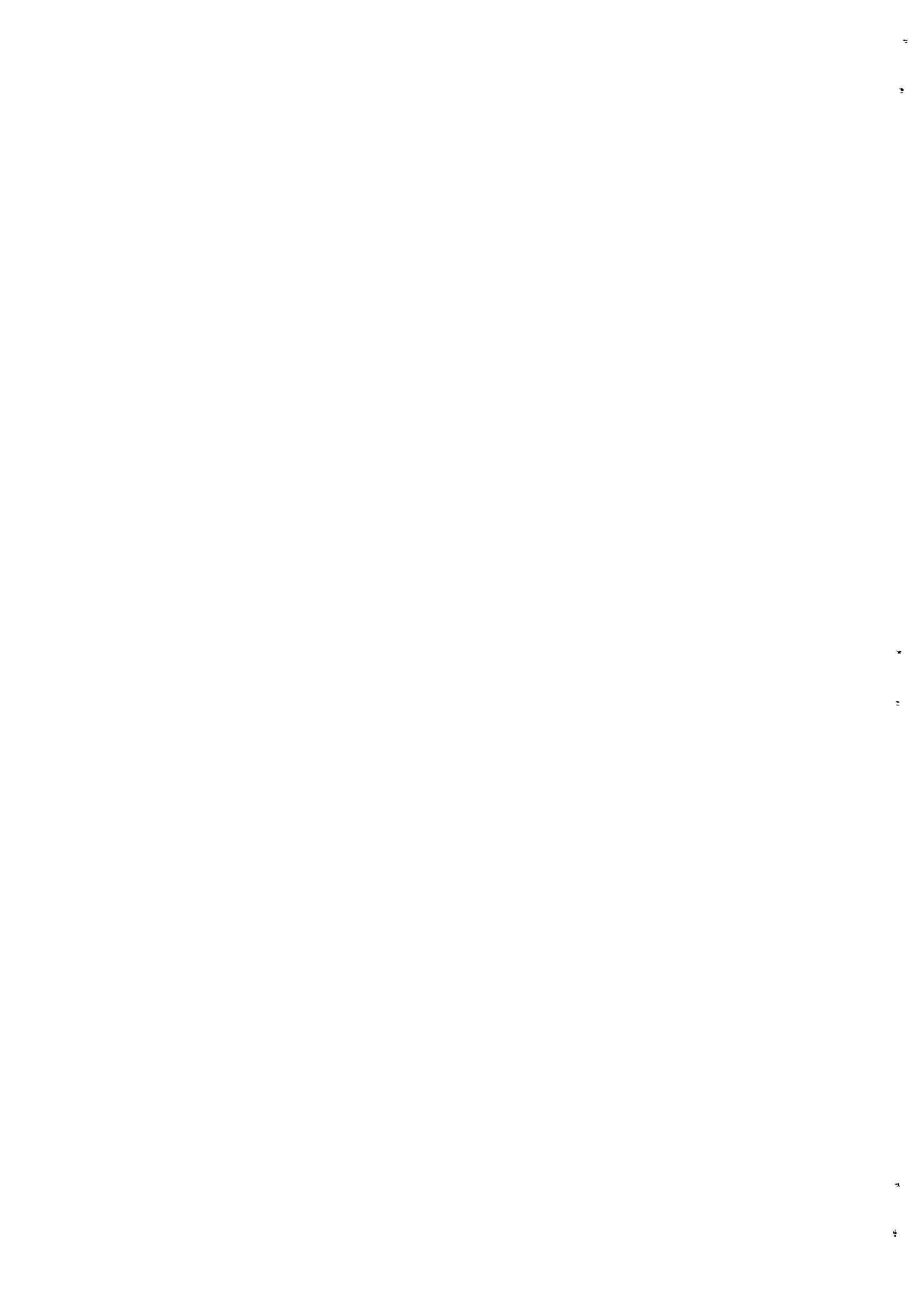

$$Y=bX+a$$

$$b= 0.6656E+00$$

$$a=-0.3506E+00$$

de correlatiecoëfficiënt  $R= 0.9789E+00$   
 de residuele standaardafwijking  $S(y,x)= 0.2268E+00$   
 de standaardfout in het intercept  $S(a)= 0.9381E-01$   
 de standaardfout in res.coëfficiënt b:  $S(b)= 0.2628E-01$   
 toetsins voor het intercept a,  
 met (N-2) vrijheidsgraden  $t= 0.3737E+01$   
 toetsins voor resressiecoëfficiënt b  
 met (N-2) vrijheidsgraden  $t= 0.2533E+02$   
 de totale Kwadraatsom  
 met (N-1) vrijheidsgraden  $SS(y)= 0.3446E+02$   
 de Kwadraatsom, toe te schrijven  
 aan de resressieverselijken  $SS(res)= 0.3302E+02$   
 de Kwadraatsom, toe te schrijven  
 aan afwijkingen van de resressie-  
 verselijken met (N-2) vrijh.grad.  $SS(res)= 0.1441E+01$

De in te voerde punten zijn:

n	X-waarde	Y-waarde
1	1.100	0.500
2	3.650	1.900
3	1.350	0.350
4	4.850	3.200
5	4.450	2.800
6	1.000	0.200
7	3.250	2.300
8	1.100	0.350
9	4.050	2.300
10	5.000	3.400
11	1.850	0.900
12	1.350	0.800
13	4.350	2.450
14	5.000	3.100
15	4.400	2.300
16	2.850	1.250
17	5.150	3.000
18	2.000	0.900
19	5.650	3.400
20	5.800	3.450
21	1.100	0.450
22	4.500	2.250
23	1.800	1.000
24	4.650	2.350
25	2.250	1.250
26	3.100	1.600
27	1.350	0.300
28	4.500	2.900
29	3.300	1.800
30	1.350	0.700



$$Y=bX+a$$

$$b= 0.6477E+00$$

$$a=-0.3266E+00$$

de correlatiecoefficient	R= 0.9387E+00
de residuele standaardafwijking	S(y,x)= 0.2866E+00
de standaardfout in het intercept	S(a)= 0.1497E+00
de standaardfout in res.coefficient b:	S(b)= 0.4756E-01
toetsins voor het intercept a, met (N-2) vrijheidsgraden	t= 0.2182E+01
toetsins voor resressiecoefficient b met (N-2) vrijheidsgraden	t= 0.1362E+02
de totale Kwadraatsom met (N-1) vrijheidsgraden	SS(y)= 0.1730E+02
de Kwadraatsom, toe te schrijven aan de resressieverselijken	SS(res)= 0.1524E+02
de Kwadraatsom, toe te schrijven aan afwijkingen van de resressie- verselijken met (N-2) vrijh.grad.	SS(res)= 0.2054E+01

De ingevoerde punten zijn:

n	X-waarde	Y-waarde
1	3.000	1.300
2	4.000	2.550
3	3.100	1.550
4	2.250	1.200
5	4.350	2.500
6	2.200	0.950
7	1.450	0.750
8	2.000	1.050
9	2.850	1.600
10	2.950	1.350
11	1.100	0.500
12	1.300	0.150
13	2.000	0.600
14	3.600	1.900
15	3.150	1.850
16	2.650	1.450
17	2.250	1.300
18	4.100	1.900
19	1.800	0.900
20	4.750	3.250
21	5.400	3.600
22	2.650	1.950
23	5.350	2.600
24	2.500	1.200
25	4.000	1.950
26	2.650	1.600
27	1.600	0.850





$$Y=bX+a$$

$$b= 0.5961E+00$$

$$a=-0.2929E+00$$

de correlatiecoefficient	R= 0.9691E+00
de residuele standaardafwijking	S(y,x)= 0.2539E+00
de standaardfout in het intercept	S(a)= 0.9303E-01
de standaardfout in res.coefficient b:	S(b)= 0.2643E-01
toetsing voor het intercept a, met (N-2) vrijheidsgraden	t= 0.3148E+01
toetsing voor regressiecoefficient b met (N-2) vrijheidsgraden	t= 0.2255E+02
de totale kwadraatsum met (N-1) vrijheidsgraden	SS(y)= 0.3492E+02
de kwadraatsum, toe te schrijven aan de regressievergelijking	SS(rea)= 0.3279E+02
de kwadraatsum, toe te schrijven aan afwijkingen van de regressie- vergelijking met (N-2) vrijh.grad.	SS(res)= 0.2128E+01

De ingevoerde punten zijn:

n	X-waarde	Y-waarde
1	1.150	0.600
2	3.600	2.200
3	1.100	0.000
4	1.150	0.450
5	4.000	2.300
6	5.300	2.550
7	1.100	0.000
8	1.950	0.800
9	5.050	2.800
10	4.600	2.600
11	5.250	2.950
12	2.750	1.500
13	1.600	0.400
14	4.100	1.600
15	4.750	2.000
16	2.300	1.000
17	5.650	3.250
18	3.250	1.450
19	1.300	0.500
20	5.600	3.000
21	1.100	0.600
22	2.650	1.600
23	1.050	0.500
24	1.500	0.950
25	4.500	2.700
26	5.300	3.050
27	1.400	0.850
28	4.000	1.900
29	2.500	1.100
30	1.200	0.250
31	3.950	2.300
32	1.500	0.450
33	4.350	2.300
34	3.250	1.400
35	5.500	3.000

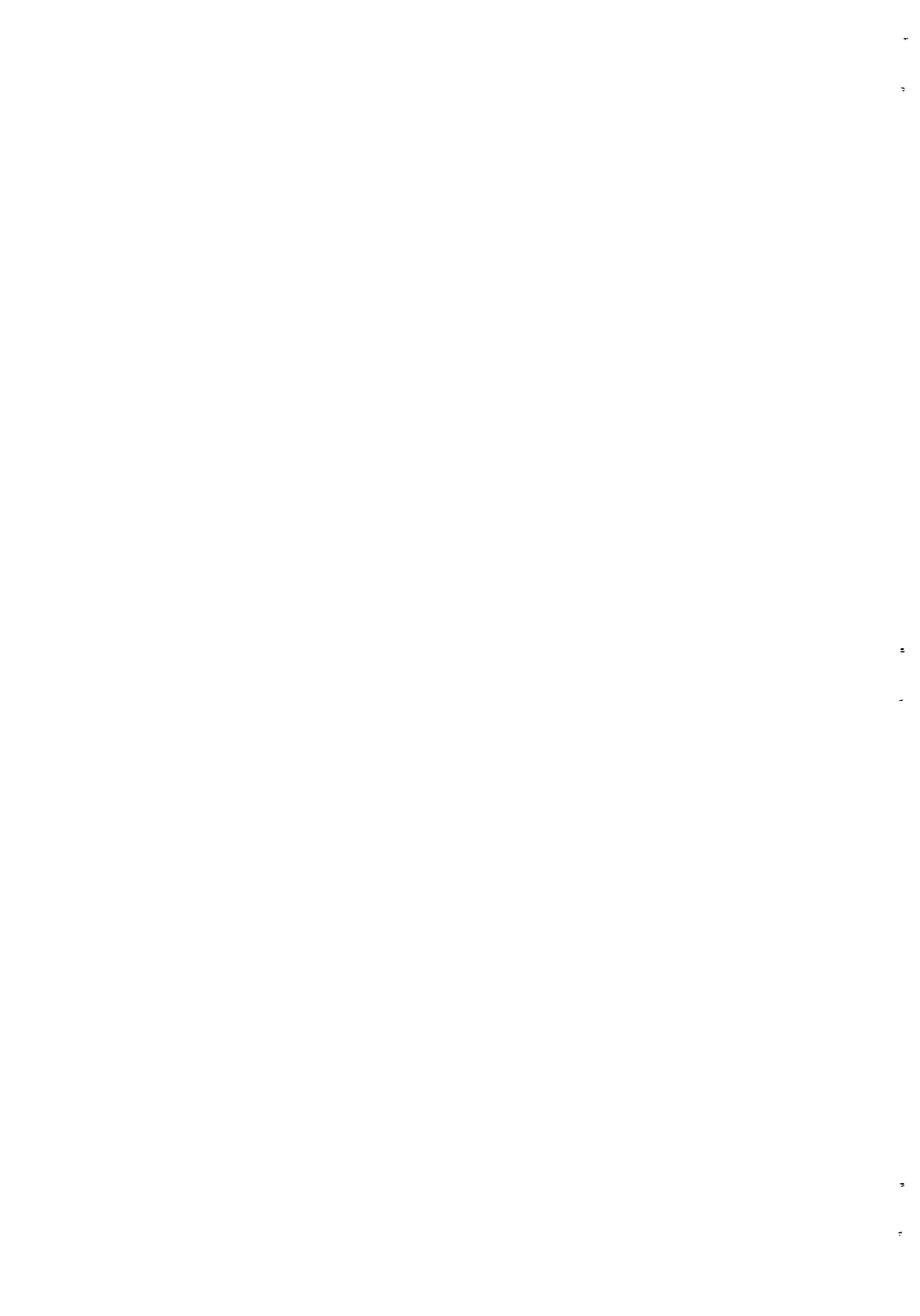

$$Y=bX+a$$

$$b= 0.5510E+00$$

$$a=-0.2772E+00$$

de correlatiecoefficient	R= 0.9864E+00
de residuele standaardafwijking	S(y,x)= 0.1241E+00
de standaardfout in het intercept	S(a)= 0.5574E-01
de standaardfout in res.coefficient b:	S(b)= 0.1735E-01
toetsins voor het intercept a, met (N-2) vrijheidsgraden	t= 0.4972E+01
toetsins voor ressessiecoefficient b met (N-2) vrijheidsgraden	t= 0.3175E+02
de totale kwadraatsom met (N-1) vrijheidsgraden	SS(y)= 0.1596E+02
de kwadraatsom, toe te schrijven aan de ressessieverselijking	SS(res)= 0.1553E+02
de kwadraatsom, toe te schrijven aan afwijkingen van de ressessie- verselijking met (N-2) vrijh.grad.	SS(res)= 0.4312E+00

De ingevoerde punten zijn:

n	X-waarde	Y-waarde
1	2.000	0.800
2	4.100	2.100
3	4.600	2.150
4	2.350	0.800
5	4.900	2.450
6	0.600	0.400
7	3.400	1.750
8	1.350	0.500
9	4.700	2.250
10	4.750	2.250
11	3.000	1.500
12	4.650	2.300
13	1.750	0.500
14	3.500	1.600
15	4.200	1.900
16	1.600	0.600
17	3.100	1.450
18	1.950	0.750
19	4.500	2.200
20	1.000	0.100
21	3.200	1.500
22	1.100	0.400
23	3.900	2.000
24	3.800	1.950
25	3.250	1.500
26	2.950	1.450
27	0.850	0.150
28	2.850	1.400
29	1.350	0.300
30	2.800	1.200

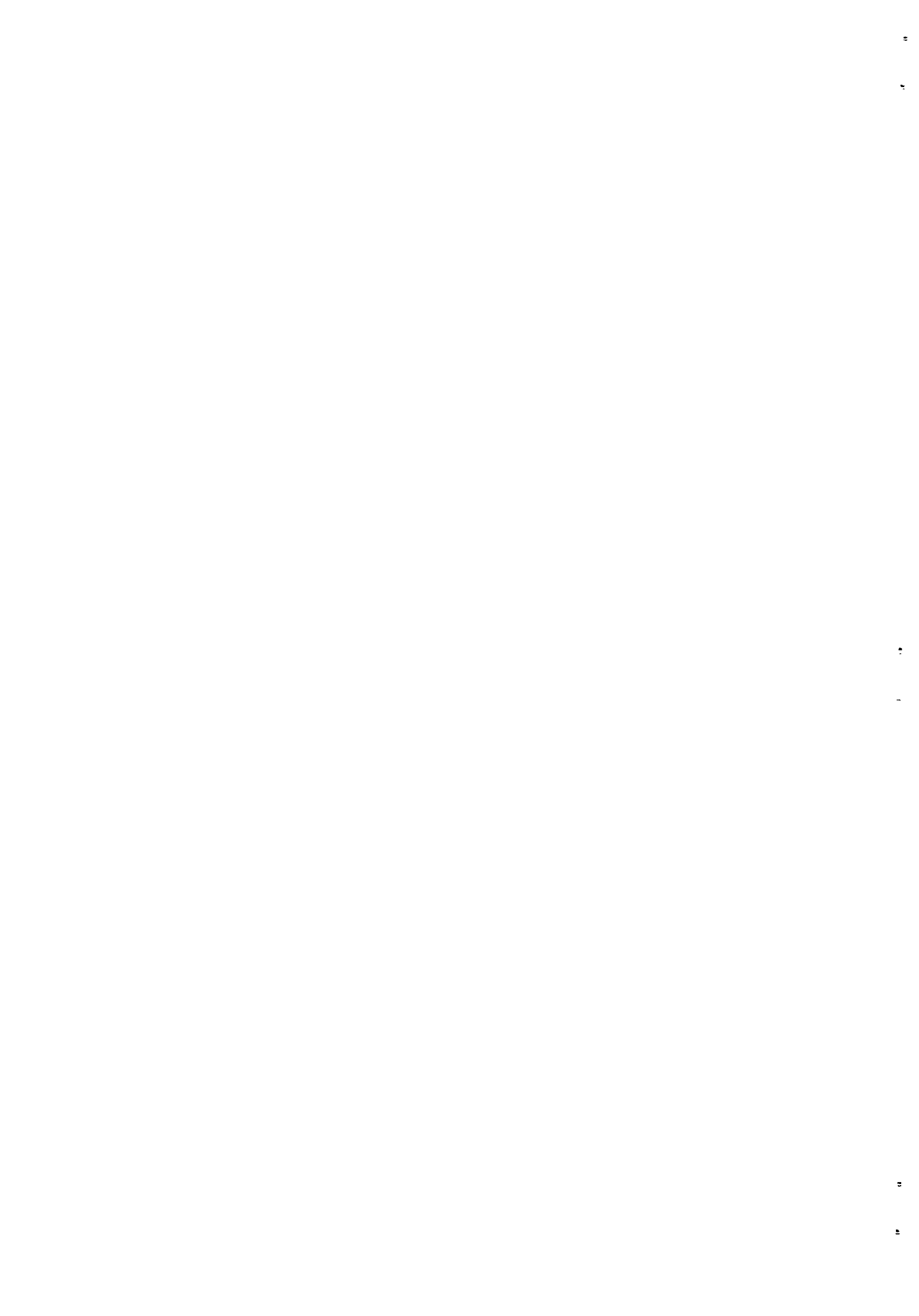

$$Y = bX + a$$

$$b = 0.5521E+00$$

$$a = -0.2650E+00$$

de correlatiecoëfficiënt	R = 0.9670E+00
de residuele standaardafwijking	S(y,x) = 0.1505E+00
de standaardfout in het intercept	S(a) = 0.6349E-01
de standaardfout in res.coëfficiënt b:	S(b) = 0.2700E-01
toetsins voor het intercept a, met (N-2) vrijheidsgraden	t = 0.4173E+01
toetsins voor resressiecoëfficiënt b met (N-2) vrijheidsgraden	t = 0.2045E+02
de totale kwadraatsom met (N-1) vrijheidsgraden	SS(y) = 0.1013E+02
de kwadraatsom, toe te schrijven aan de resressieverselijken	SS(res) = 0.9470E+01
de kwadraatsom, toe te schrijven aan afwijkingen van de resressie- verselijken met (N-2) vrijh.grad.	SS(res) = 0.6569E+00

De insevoerde punten zijn:

n	X-waarde	Y-waarde
1	2.800	1.350
2	1.800	0.900
3	0.700	0.250
4	1.800	0.850
5	0.450	0.050
6	3.100	1.250
7	0.500	0.000
8	3.000	1.400
9	1.950	0.800
10	3.350	1.600
11	1.950	0.600
12	3.400	1.700
13	3.700	1.900
14	3.000	1.400
15	2.600	1.300
16	1.250	0.400
17	2.700	1.250
18	0.750	0.300
19	1.800	0.500
20	2.850	1.300
21	2.150	0.900
22	3.300	1.500
23	0.550	0.000
24	2.950	1.000
25	2.000	0.600
26	0.750	0.150
27	2.500	1.500
28	1.300	0.400
29	3.100	1.600
30	3.100	1.400
31	0.800	0.050



$\hat{y} = bX + a$   
 $b = 0.5964E+00$   
 $a = -0.3770E+00$   
 de correlatiecoëfficiënt  $R = 0.9743E+00$   
 de residuele standaardafwijking  $S(y,x) = 0.2453E+00$   
 de standaardfout in het intercept  $S(a) = 0.8279E-01$   
 de standaardfout in res.coëfficiënt b:  $S(b) = 0.2517E-01$   
 toetsing voor het intercept a, met (N-2) vrijheidsgraden  $t = 0.4554E+01$   
 toetsing voor regressiecoëfficiënt b met (N-2) vrijheidsgraden  $t = 0.2369E+02$   
 de totale kwadraatsom met (N-1) vrijheidsgraden  $SS(y) = 0.3559E+02$   
 de kwadraatsom toe te schrijven aan de regressievergelijking  $SS(res) = 0.3378E+02$   
 de kwadraatsom toe te schrijven aan afwijkingen van de regressievergelijking met (N-2) vrijh.grad.  $SS(res) = 0.1806E+01$

De ingevoerde punten zijn:

n	X-waarde	Y-waarde
1	1.000	0.000
2	1.700	0.650
3	2.100	1.200
4	0.550	0.250
5	3.350	1.600
6	2.700	1.350
7	0.800	0.100
8	2.100	1.000
9	1.250	0.250
10	4.000	2.250
11	4.100	2.000
12	3.900	1.950
13	0.850	0.300
14	1.350	0.600
15	4.100	1.850
16	3.800	1.650
17	1.400	0.450
18	1.050	0.300
19	1.650	2.200
20	3.700	1.650
21	4.350	2.250
22	1.200	0.050
23	2.650	1.200
24	4.250	1.700
25	1.500	0.050
26	6.350	3.600
27	6.800	3.700
28	1.900	0.550
29	1.000	0.150
30	5.600	3.550
31	1.100	0.600
32	1.000	2.200



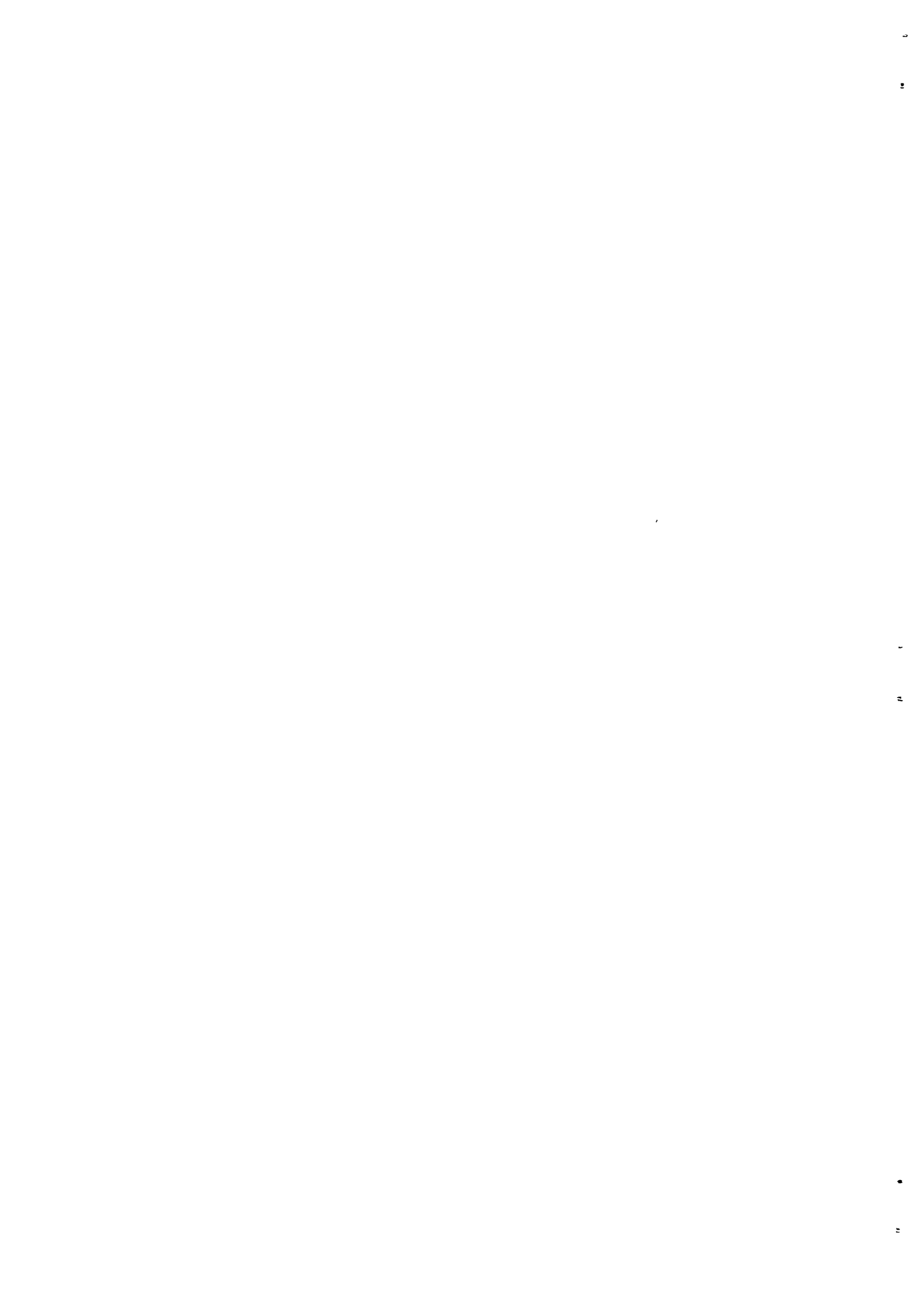

$$Y=bX+a$$

$$b= 0.5130E+00$$

$$a=-0.2225E+00$$

$$\text{de correlatiecoefficient} \quad R= 0.9349E+00$$

$$\text{de residuele standaardafwijking} \quad S(y,x)= 0.2433E+00$$

$$\text{de standaardfout in het intercept} \quad S(a)= 0.1022E+00$$

$$\text{de standaardfout in res.coefficient b:} \quad S(b)= 0.3680E-01$$

$$\text{toetsing voor het intercept a,} \\ \text{met (N-2) vrijheidsgraden} \quad t= 0.2178E+01$$

$$\text{toetsing voor regressiecoefficient b} \\ \text{met (N-2) vrijheidsgraden} \quad t= 0.1394E+02$$

$$\text{de totale kwadraatsom} \\ \text{met (N-1) vrijheidsgraden} \quad SS(y)= 0.1316E+02$$

$$\text{de kwadraatsom, toe te schrijven} \\ \text{aan de regressievergelijking} \quad SS(\text{res})= 0.1150E+02$$

$$\text{de kwadraatsom, toe te schrijven} \\ \text{aan afwijkingen van de regressie-} \\ \text{vergelijking met (N-2) vrijh.grad.} \quad SS(\text{res})= 0.1657E+01$$

De ingevoerde punten zijn:

n	X-waarde	Y-waarde
1	2.700	1.000
2	0.600	0.000
3	3.100	1.300
4	3.400	2.050
5	1.350	0.400
6	4.500	1.600
7	1.800	0.400
8	1.000	0.100
9	4.350	1.800
10	4.150	1.400
11	1.350	0.600
12	1.100	0.250
13	4.650	2.150
14	2.150	0.750
15	3.150	1.450
16	1.750	0.500
17	4.150	2.200
18	2.750	1.100
19	3.200	1.700
20	1.500	0.550
21	3.350	1.400
22	1.250	0.450
23	1.050	0.300
24	3.000	1.400
25	2.950	1.800
26	1.000	0.350
27	2.800	1.450
28	3.100	1.600
29	3.150	1.550
30	0.650	0.200

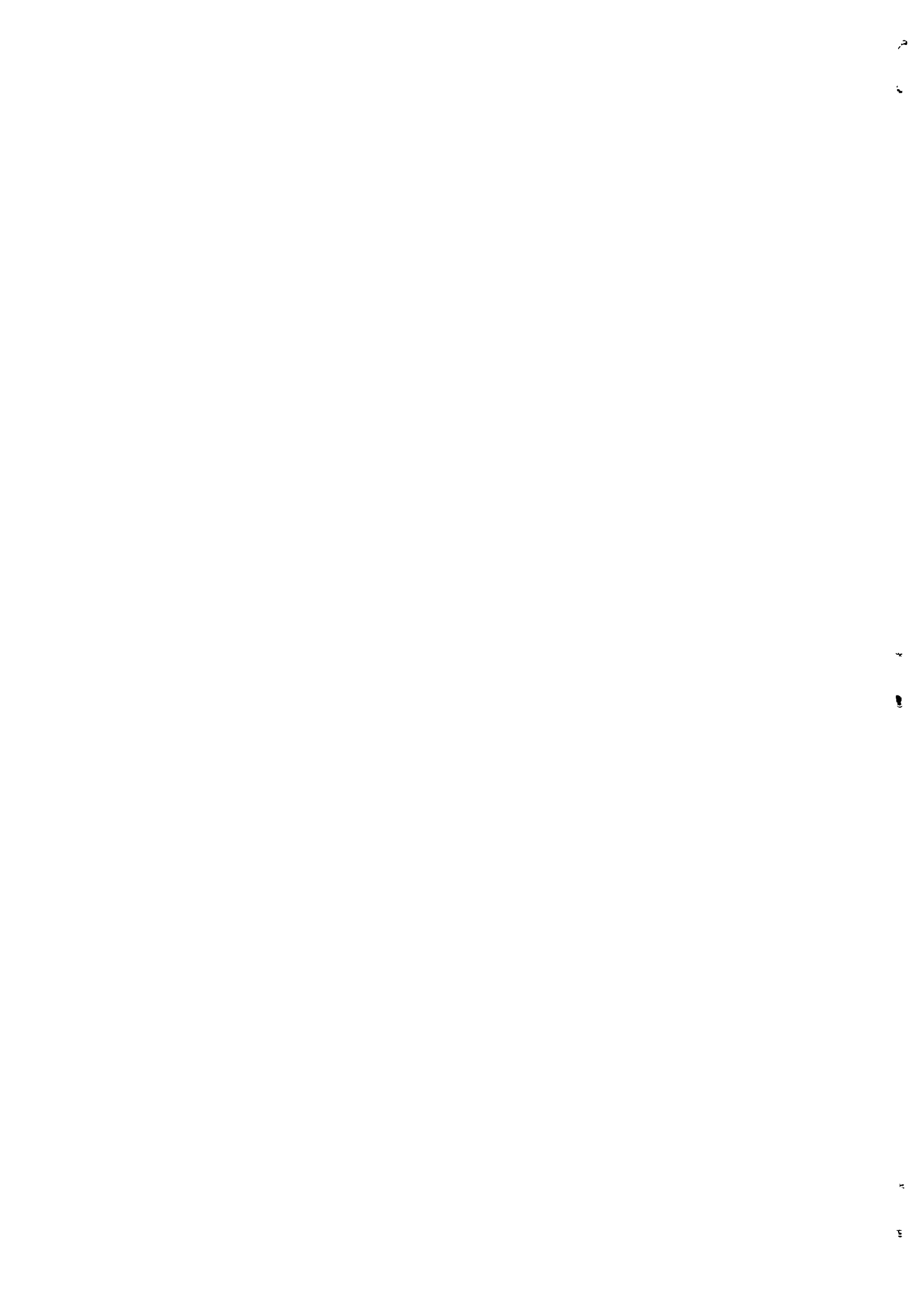

$$Y=bX+a$$

$$b= 0.5763E+00$$

$$a=-0.2906E+00$$

de correlatiecoefficient  $R= 0.9861E+00$   
 de residuele standaardafwijking  $S(y,x)= 0.1539E+00$   
 de standaardfout in het intercept  $S(a)= 0.5756E-01$   
 de standaardfout in res.coefficient b:  $S(b)= 0.1836E-01$   
 toetsins voor het intercept a,  
 met (N-2) vrijheidsraden  $t= 0.5048E+01$   
 toetsins voor resreessiecoefficient b  
 met (N-2) vrijheidsraden  $t= 0.3140E+02$   
 de totale Kwadraatsom  
 met (N-1) vrijheidsraden  $SS(y)= 0.2401E+02$   
 de Kwadraatsom, toe te schrijven  
 aan de resreessieverselijking  $SS(res)= 0.2334E+02$   
 de Kwadraatsom, toe te schrijven  
 aan afwijkingen van de resreessie-  
 verselijking met (N-2) vrijh. grad.  $SS(res)= 0.6630E+00$

De insevoerde punten zijn:

n	X-waarde	Y-waarde
1	1.100	0.300
2	3.250	1.650
3	1.100	0.500
4	4.850	2.700
5	3.400	1.700
6	3.400	1.650
7	1.200	0.350
8	4.100	2.000
9	3.050	1.700
10	1.000	0.300
11	4.200	2.050
12	1.100	0.200
13	3.350	1.700
14	1.500	0.500
15	1.000	0.220
16	0.900	0.180
17	4.250	2.200
18	4.650	2.200
19	2.000	0.850
20	3.050	1.650
21	5.000	2.600
22	1.600	0.500
23	3.100	1.650
24	0.800	0.250
25	3.950	2.400
26	3.800	1.800
27	2.450	0.800
28	6.550	3.200
29	1.100	0.300
30	1.300	0.500

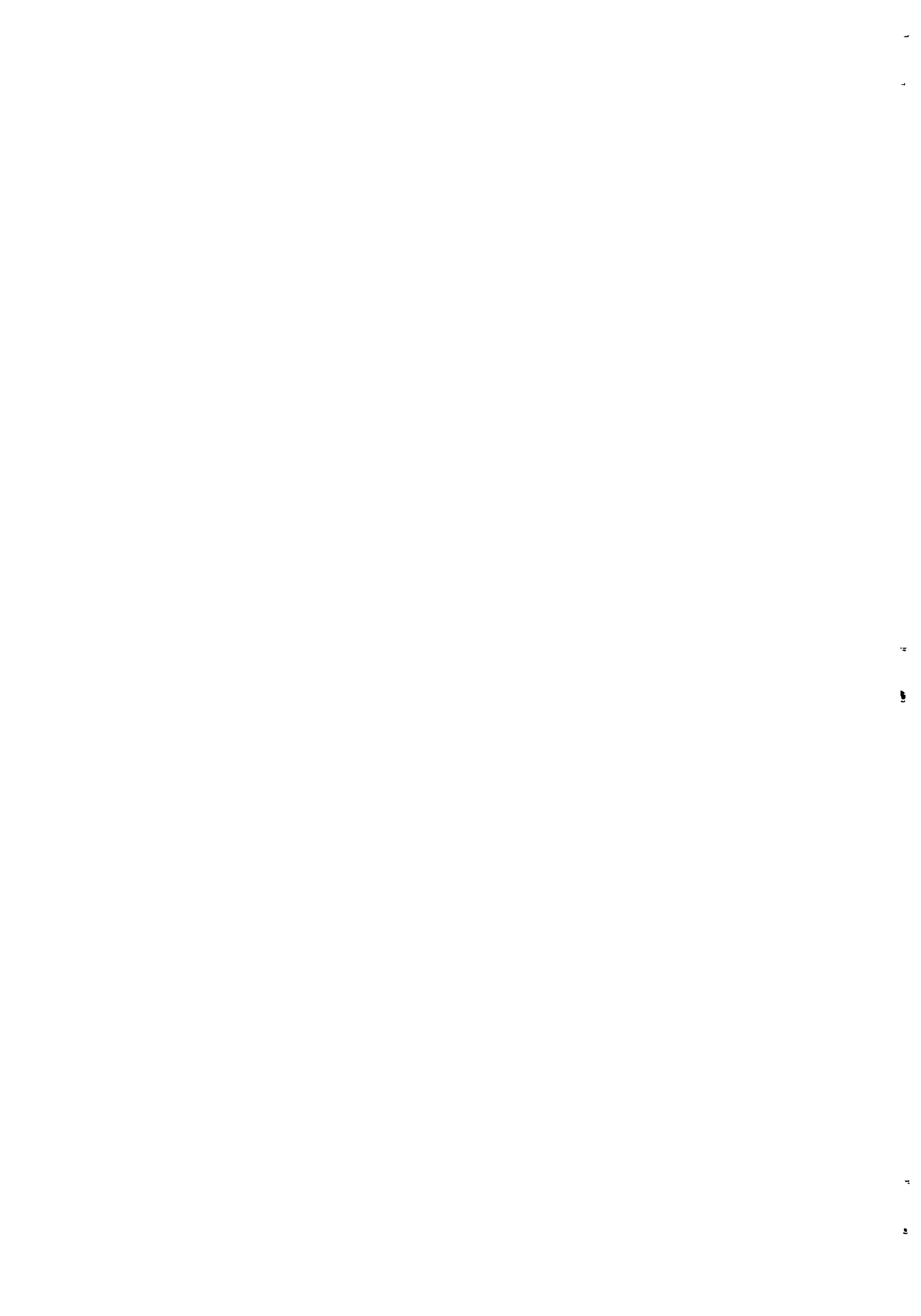

$Y=bX+a$   
 $b= 0.5856E+00$   
 $a=-0.3598E+00$   
 de correlatiecoëfficiënt  $R= 0.9414E+00$   
 de residuele standaardafwijking  $S(y,x)= 0.2130E+00$   
 de standaardfout in het intercept  $S(a)= 0.1122E+00$   
 de standaardfout in res.coëfficiënt b:  $S(b)= 0.3895E-01$   
 toetsing voor het intercept a,  
 met (N-2) vrijheidsgraden  $t= 0.3296E+01$   
 toetsing voor regressiecoëfficiënt b  
 met (N-2) vrijheidsgraden  $t= 0.1504E+02$   
 de totale Kwadraatsom  $SS(y)= 0.1157E+02$   
 met (N-1) vrijheidsgraden  
 de Kwadraatsom, toe te schrijven  
 aan de regressievergelijking  $SS(res)= 0.1026E+02$   
 de Kwadraatsom, toe te schrijven  
 aan afwijkingen van de regressie-  
 vergelijking met (N-2) vrijh.grad.  $SS(res)= 0.1316E+01$

De ingevoerde punten zijn:

n	X-waarde	Y-waarde
1	2.500	1.050
2	1.250	0.450
3	2.650	1.150
4	1.100	0.000
5	3.000	1.400
6	1.500	0.650
7	3.000	1.550
8	3.250	1.700
9	2.000	0.950
10	3.100	1.500
11	0.650	0.000
12	1.900	0.800
13	3.350	1.450
14	3.750	1.250
15	1.350	0.450
16	2.100	0.850
17	3.700	2.000
18	2.600	1.050
19	3.400	1.500
20	2.150	1.000
21	2.150	0.900
22	3.450	1.750
23	2.950	1.450
24	3.900	1.900
25	3.100	2.000
26	1.600	0.600
27	3.500	1.250
28	4.000	1.950
29	3.800	1.850
30	2.300	0.600
31	4.900	2.700

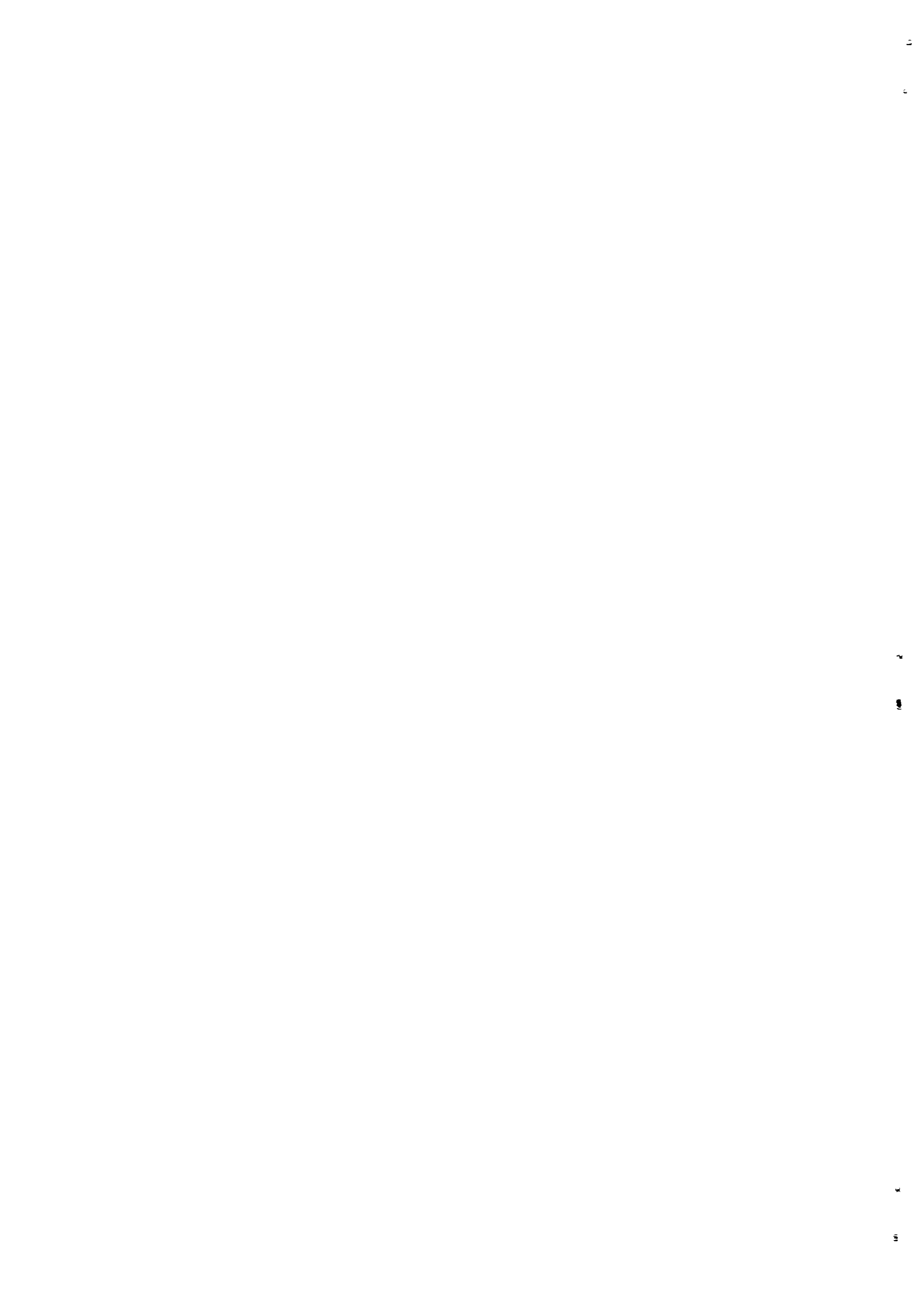

$$Y=bX+a$$

$$b= 0.5460E+00$$

$$a=-0.3507E+00$$

de correlatiecoefficient  $R= 0.9896E+00$   
 de residuele standaardafwijking  $S(y,x)= 0.1323E+00$   
 de standaardfout in het intercept  $S(a)= 0.5475E-01$   
 de standaardfout in res.coefficient b:  $S(b)= 0.1501E-01$   
 toetsing voor het intercept a,  
 met (N-2) vrijheidsgraden  $t= 0.6405E+01$   
 toetsing voor regressiecoefficient b  
 met (N-2) vrijheidsgraden  $t= 0.3638E+02$   
 de totale kwadraatsom  
 met (N-1) vrijheidsgraden  $SS(y)= 0.2366E+02$   
 de kwadraatsom, toe te schrijven  
 aan de regressievergelijking  $SS(res)= 0.2317E+02$   
 de kwadraatsom, toe te schrijven  
 aan afwijkingen van de regressie-  
 vergelijking met (N-2) vrijh.grad.  $SS(res)= 0.4904E+00$

De ingevoerde punten zijn:

n	X-waarde	Y-waarde
1	1.000	0.000
2	2.350	0.700
3	2.600	0.850
4	6.100	2.950
5	4.000	1.700
6	1.800	0.600
7	1.650	0.500
8	4.450	2.200
9	0.900	0.200
10	4.400	2.200
11	4.800	2.400
12	2.050	0.950
13	4.350	2.150
14	3.850	1.600
15	1.350	0.450
16	4.750	2.300
17	2.000	0.850
18	2.000	0.850
19	5.600	2.600
20	5.700	2.800
21	1.300	0.450
22	2.950	1.100
23	5.200	2.600
24	2.300	0.850
25	4.850	2.450
26	1.500	0.450
27	4.650	2.050
28	3.700	1.650
29	4.950	2.200
30	1.100	0.450



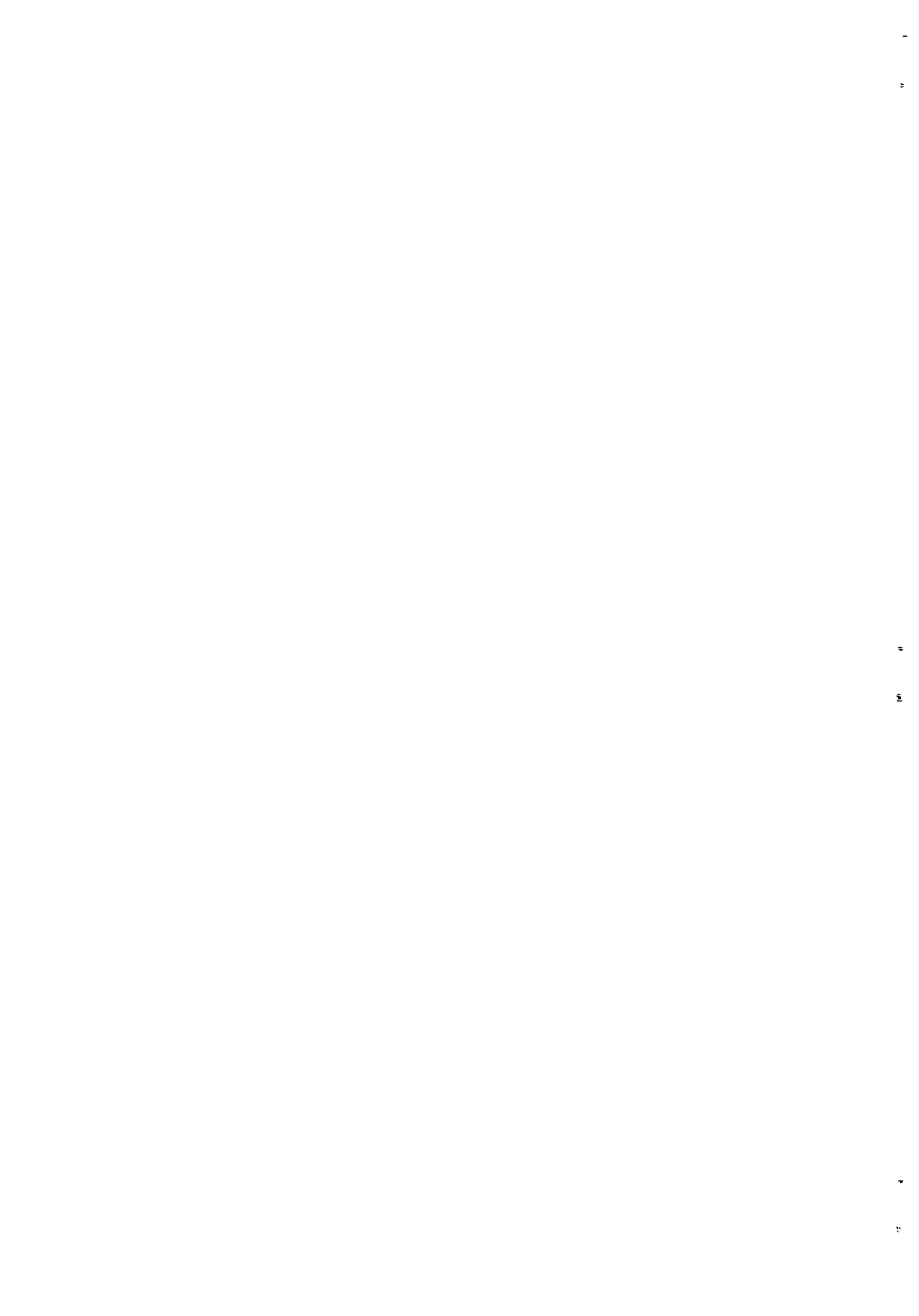

$Y = bX + a$   
 $b = 0.6121E+00$   
 $a = -0.3886E+00$   
 de correlatiecoëfficiënt  $R = 0.9684E+00$   
 de residuele standaardafwijking  $S(y,x) = 0.2754E+00$   
 de standaardfout in het intercept  $S(a) = 0.1114E+00$   
 de standaardfout in res.coëfficiënt b:  $S(b) = 0.2982E-01$   
 toetsing voor het intercept a,  
 met (N-2) vrijheidsgraden  $t = 0.3489E+01$   
 toetsing voor regressiecoëfficiënt b  
 met (N-2) vrijheidsgraden  $t = 0.2053E+02$   
 de totale Kwadraatsom  
 met (N-1) vrijheidsgraden  $SS(y) = 0.3408E+02$   
 de Kwadraatsom, toe te schrijven  
 aan de regressievergelijking  $SS(res) = 0.3195E+02$   
 de Kwadraatsom, toe te schrijven  
 aan afwijkingen van de regressie-  
 vergelijking met (N-2) vrijh.grad.  $SS(res) = 0.2123E+01$

De ingevoerde punten zijn:

n	X-waarde	Y-waarde
1	5.650	3.200
2	1.000	0.000
3	4.250	2.500
4	1.200	0.700
5	3.850	2.000
6	1.000	0.050
7	3.400	1.600
8	3.400	2.900
9	3.200	1.450
10	5.200	2.700
11	0.800	0.000
12	4.950	2.600
13	2.150	0.900
14	4.600	2.250
15	4.000	2.050
16	4.350	2.350
17	5.900	3.000
18	0.800	0.250
19	3.000	1.600
20	1.750	0.600
21	5.750	3.000
22	1.600	0.550
23	1.400	0.400
24	4.400	2.200
25	4.500	2.450
26	2.150	0.750
27	5.700	3.000
28	2.200	0.800
29	2.100	0.650
30	5.750	3.050



$$Y=bX+a$$

$$b= 0.7921E+00$$

$$a=-0.3903E+00$$

de correlatiecoëfficiënt	R= 0.9801E+00
de residuele standaardafwijking	S(y,x)= 0.2304E+00
de standaardfout in het intercept	S(a)= 0.1169E+00
de standaardfout in res.coëfficiënt b:	S(b)= 0.3031E-01
toetsins voor het intercept a, met (N-2) vrijheidsgraden	t= 0.3339E+01
toetsins voor resressiecoëfficiënt b met (N-2) vrijheidsgraden	t= 0.2613E+02
de totale Kwadraatsom met (N-1) vrijheidsgraden	SS(y)= 0.3774E+02
de Kwadraatsom, toe te schrijven aan de resressieverselijking	SS(res)= 0.3626E+02
de Kwadraatsom, toe te schrijven aan afwijkingen van de resressie- verselijking met (N-2) vrijh.grad.	SS(res)= 0.1486E+01

De ingevoerde punten zijn:

n	X-waarde	Y-waarde
1	2.600	1.550
2	4.650	3.550
3	3.100	2.150
4	2.350	1.900
5	4.800	3.250
6	3.650	2.650
7	5.100	3.500
8	3.100	2.200
9	4.150	2.900
10	6.950	5.000
11	6.100	4.100
12	3.450	2.400
13	2.100	1.100
14	3.950	3.000
15	4.550	3.200
16	2.550	1.350
17	3.850	2.700
18	4.050	2.800
19	4.000	2.350
20	2.400	1.200
21	5.300	3.850
22	2.500	1.750
23	1.100	0.200
24	0.450	0.100
25	4.100	3.250
26	2.700	1.950
27	1.850	0.800
28	4.600	3.600
29	3.600	2.350
30	4.500	3.100

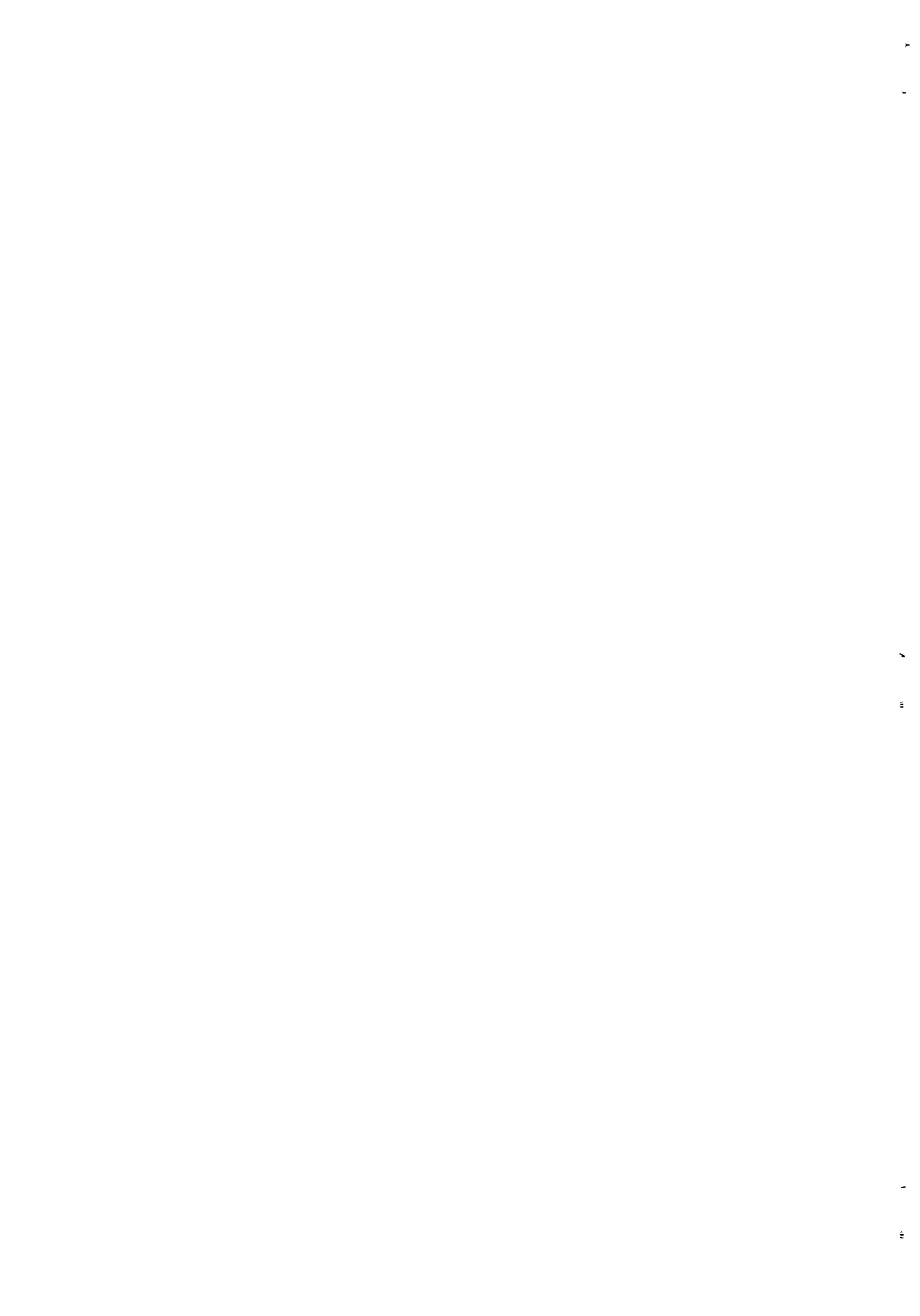

$$Y=bX+a$$

$$b= 0.7545E+00$$

$$a=-0.4326E+00$$

de correlatiecoefficient  $R= 0.9694E+00$   
 de residuele standaardafwijking  $S(y,x)= 0.3110E+00$   
 de standaardfout in het intercept  $S(a)= 0.1293E+00$   
 de standaardfout in res.coefficient b:  $S(b)= 0.3489E-01$   
 toetsins voor het intercept a,  
 met (N-2) vrijheidsgraden  $t= 0.3345E+01$   
 toetsins voor resresessiecoefficient b  
 met (N-2) vrijheidsgraden  $t= 0.2162E+02$   
 de totale Kwadraatsom  
 met (N-1) vrijheidsgraden  $SS(y)= 0.4814E+02$   
 de kwadraatsom, toe te schrijven  
 aan de resresessieverselijking  $SS(res)= 0.4524E+02$   
 de kwadraatsom, toe te schrijven  
 aan afwijkingen van de resresessie-  
 verselijking met (N-2) vrijh.grad.  $SS(res)= 0.2902E+01$

De insevoerde punten zijn:

n	X-waarde	Y-waarde
1	5.400	4.000
2	5.150	3.200
3	4.350	2.850
4	1.350	0.550
5	1.000	0.650
6	1.100	0.700
7	4.000	2.750
8	4.200	3.000
9	4.400	2.800
10	3.400	1.650
11	3.650	1.800
12	4.100	2.000
13	4.750	3.250
14	6.000	4.350
15	0.750	0.000
16	4.500	2.250
17	4.000	2.750
18	3.950	2.600
19	3.000	2.200
20	0.700	0.000
21	4.000	2.950
22	1.350	0.450
23	4.350	3.150
24	1.350	0.600
25	1.750	0.650
26	2.500	1.750
27	5.300	3.750
28	2.050	1.200
29	3.600	2.300
30	2.000	1.150
31	6.250	4.300
32	3.100	1.350



$$Y = bX + a$$

$$b = 0.6955E+00$$

$$a = -0.5164E+00$$

de correlatiecoefficient  $R = 0.9183E+00$   
 de residuele standaardafwijking  $S(y,x) = 0.4113E+00$   
 de standaardfout in het intercept  $S(a) = 0.1725E+00$   
 de standaardfout in res.coefficient b:  $S(b) = 0.5666E-01$   
 toetsing voor het intercept a,  
 met (N-2) vrijheidsgraden  $t = 0.2994E+01$   
 toetsing voor regressiecoefficient b  
 met (N-2) vrijheidsgraden  $t = 0.1227E+02$   
 de totale kwadraatsom  
 met (N-1) vrijheidsgraden  $SS(y) = 0.3022E+02$   
 de kwadraatsom, toe te schrijven  
 aan de regressieveranderingen  $SS(res) = 0.2548E+02$   
 de kwadraatsom, toe te schrijven  
 aan afwijkingen van de regressie-  
 veranderingen met (N-2) vrijh.grad.  $SS(res) = 0.4736E+01$

De ingevoerde punten zijn:

n	X-waarde	Y-waarde
1	0.700	0.300
2	4.600	2.500
3	3.600	1.450
4	1.100	0.450
5	2.250	1.050
6	0.950	0.730
7	2.500	1.100
8	1.050	0.050
9	4.600	2.200
10	2.150	0.700
11	3.500	1.400
12	4.000	1.850
13	2.800	1.050
14	3.800	1.650
15	3.350	1.450
16	0.550	0.000
17	2.050	0.650
18	1.200	0.200
19	2.200	1.000
20	3.750	2.700
21	3.250	2.050
22	1.100	0.000
23	1.050	0.000
24	3.200	1.500
25	5.100	3.700
26	3.750	2.650
27	2.150	1.050
28	3.100	2.350
29	4.050	3.100
30	4.750	2.800





$$Y=bX+a$$

$$b=0.7741E+00$$

$$a=-0.4941E+00$$

de correlatiecoëfficiënt	R= 0.7621E+00
de residuele standaardafwijking	S(y,x)= 0.4976E+00
de standaardfout in het intercept	S(a)= 0.2357E+00
de standaardfout in res.coëfficiënt b:	S(b)= 0.1123E+00
toetsins voor het intercept a, met (N-2) vrijheidsgraden	t= 0.2096E+01
toetsins voor resreëssiecoëfficiënt b met (N-2) vrijheidsgraden	t= 0.6447E+01
de totale Kwadraatsom met (N-1) vrijheidsgraden	SS(y)= 0.1772E+02
de Kwadraatsom, toe te schrijven aan de resreëssieverselijking	SS(res)= 0.1029E+02
de Kwadraatsom, toe te schrijven aan afwijkingen van de resreëssie- verselijking met (N-2) vrijh.grad.	SS(res)= 0.7430E+01

De ingevoerde punten zijn:

n	X-waarde	Y-waarde
1	1.750	0.600
2	0.800	0.000
3	1.600	0.550
4	1.250	0.000
5	3.800	1.250
6	2.100	0.500
7	0.850	0.550
8	2.600	1.050
9	1.900	0.600
10	1.750	1.050
11	2.900	1.050
12	1.150	0.100
13	2.250	1.950
14	1.600	0.550
15	2.400	0.700
16	1.150	0.350
17	2.600	1.800
18	0.850	0.450
19	4.100	3.550
20	2.000	1.600
21	1.600	0.300
22	1.650	1.350
23	2.100	0.800
24	1.800	1.300
25	2.350	1.350
26	1.550	0.350
27	2.650	0.550
28	2.100	1.400
29	1.100	0.100
30	2.400	1.700
31	0.900	0.000
32	2.700	1.850



$$Y=bX+a$$

$$b= 0.7765E+00$$

$$a=-0.4644E+00$$

de correlatiecoefficient	R= 0.9875E+00
de residuele standaardafwijking	S(y,x)= 0.2144E+00
de standaardfout in het intercept	S(a)= 0.8651E-01
de standaardfout in res.coefficient b:	S(b)= 0.2298E-01
toetsins voor het intercept a, met (N-2) vrijheidsgraden	t= 0.5368E+01
toetsins voor resressiecoefficient b met (N-2) vrijheidsgraden	t= 0.3379E+02
de totale kwadraatsom met (N-1) vrijheidsgraden	SS(y)= 0.5384E+02
de kwadraatsom, toe te schrijven aan de resressieverselijking	SS(res)= 0.5251E+02
de kwadraatsom, toe te schrijven aan afwijkingen van de resressie- verselijking met (N-2) vrijh.grad.	SS(res)= 0.1333E+01

De insevoerde punten zijn:

n	X-waarde	Y-waarde
1	0.600	0.000
2	4.400	3.000
3	1.550	0.900
4	4.750	3.400
5	5.200	3.400
6	1.650	0.800
7	6.300	4.050
8	2.400	1.200
9	3.750	2.500
10	1.700	0.900
11	3.500	2.000
12	5.400	3.900
13	5.250	3.850
14	1.600	0.800
15	1.750	0.900
16	4.100	2.800
17	2.550	1.500
18	2.050	1.000
19	3.550	2.350
20	4.000	2.600
21	5.000	2.950
22	1.600	1.000
23	2.500	1.150
24	6.050	4.200
25	6.550	4.550
26	1.700	0.700
27	3.650	2.750
28	2.550	1.500
29	5.300	4.200
30	2.600	1.700
31	0.950	0.200



$$Y=bX+a$$

$$b= 0.7798E+00$$

$$a=-0.3844E+00$$

de correlatiecoefficient  $R= 0.9731E+00$   
 de residuele standaardafwijking  $S(y,x)= 0.2854E+00$   
 de standaardfout in het intercept  $S(a)= 0.1036E+00$   
 de standaardfout in res.coefficient b:  $S(b)= 0.3486E-01$   
 toetsing voor het intercept a,  
 met (N-2) vrijheidsgraden  $t= 0.3711E+01$   
 toetsing voor regressiecoefficient b  
 met (N-2) vrijheidsgraden  $t= 0.2237E+02$   
 de totale kwadraatsom  
 met (N-1) vrijheidsgraden  $SS(y)= 0.4303E+02$   
 de kwadraatsom, toe te schrijven  
 aan de regressievergelijking  $SS(res)= 0.4075E+02$   
 de kwadraatsom, toe te schrijven  
 aan afwijkingen van de regressie-  
 vergelijking met (N-2) vrijh.grad.  $SS(res)= 0.2280E+01$

De ingevoerde punten zijn:

n	X-waarde	Y-waarde
1	1.050	0.500
2	2.900	2.000
3	3.600	2.650
4	3.750	2.900
5	1.550	0.800
6	1.350	0.700
7	1.800	0.650
8	1.500	0.600
9	3.250	2.100
10	1.000	0.450
11	2.400	1.650
12	2.400	1.750
13	0.650	0.000
14	3.500	2.900
15	0.700	0.150
16	3.400	1.900
17	0.850	0.400
18	4.100	2.850
19	1.250	0.600
20	4.350	2.800
21	0.900	0.000
22	4.600	3.200
23	5.500	2.950
24	1.600	0.600
25	4.000	3.100
26	1.000	0.500
27	5.750	4.250
28	1.050	0.400
29	4.000	2.900
30	3.300	2.300



$$Y=bX+a$$

$$b= 0.4498E+00$$

$$a=-0.1685E+00$$

de correlatiecoefficient

$$R= 0.9582E+00$$

de residuele standaardafwijking

$$S(y,x)= 0.1963E+00$$

de standaardfout in het intercept

$$S(a)= 0.8239E-01$$

de standaardfout in res.coefficient b:

$$S(b)= 0.2585E-01$$

toetsins voor het intercept a,

met (N-2) vrijheidsgraden

$$t= 0.2045E+01$$

toetsins voor regressiecoefficient b

met (N-2) vrijheidsgraden

$$t= 0.1740E+02$$

de totale kwadraatsom

met (N-1) vrijheidsgraden

$$SS(y)= 0.1271E+02$$

de Kwadraatsom, toe te schrijven

aan de regressievergelijking

$$SS(res)= 0.1167E+02$$

de Kwadraatsom, toe te schrijven

aan afwijkingen van de regressie-

vergelijking met (N-2) vrijh.grad.

$$SS(res)= 0.1040E+01$$

De ingevoerde punten zijn:

n	X-waarde	Y-waarde
1	1.000	0.050
2	3.000	1.250
3	4.250	1.600
4	2.400	0.800
5	1.800	0.650
6	4.400	1.750
7	2.750	1.150
8	1.500	0.450
9	4.350	1.750
10	3.100	1.050
11	1.650	0.450
12	2.250	1.000
13	4.500	2.350
14	2.350	0.850
15	4.350	2.150
16	1.350	0.550
17	2.450	0.900
18	5.400	2.000
19	3.150	1.050
20	2.100	0.600
21	6.300	2.400
22	0.900	0.200
23	5.300	2.350
24	2.000	0.700
25	1.300	0.600
26	2.950	1.350
27	2.500	0.800
28	1.250	0.350
29	2.300	1.250



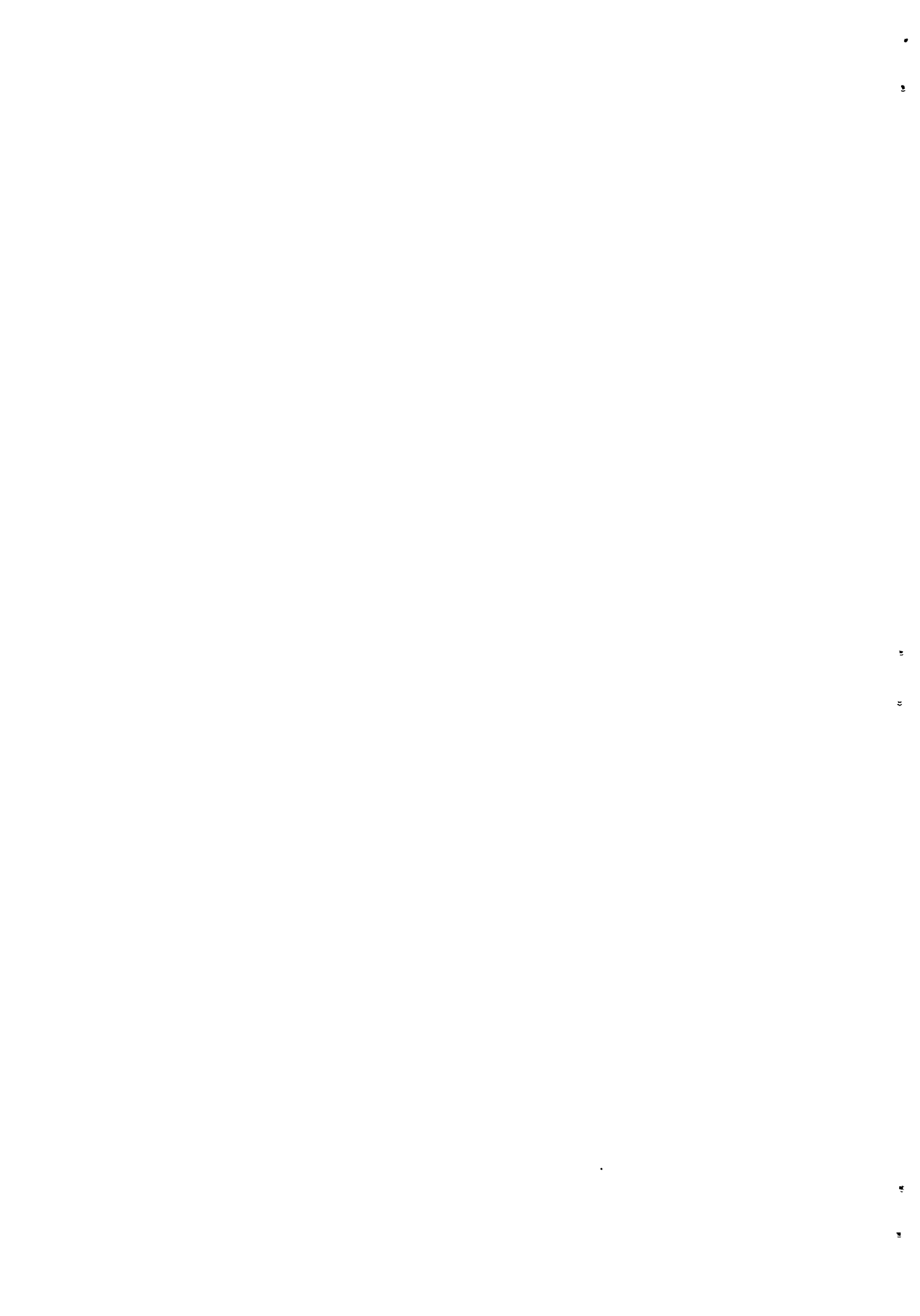

$Y=bX+a$   
 $b= 0.4494E+00$   
 $a=-0.2160E+00$   
 de correlatiecoëfficiënt  $R= 0.9700E+00$   
 de residuele standaardafwijking  $S(y,x)= 0.1644E+00$   
 de standaardfout in het intercept  $S(a)= 0.7060E-01$   
 de standaardfout in res.coëfficiënt b:  $S(b)= 0.2093E-01$   
 toetsing voor het intercept a,  
 met (N-2) vrijheidsgraden  $t= 0.3059E+01$   
 toetsing voor regressiecoëfficiënt b  
 met (N-2) vrijheidsgraden  $t= 0.2148E+02$   
 de totale Kwadraatsom  
 met (N-1) vrijheidsgraden  $SS(y)= 0.1324E+02$   
 de Kwadraatsom, toe te schrijven  
 aan de regressieverslijking  $SS(res)= 0.1246E+02$   
 de Kwadraatsom, toe te schrijven  
 aan afwijkingen van de regressie-  
 verslijking met (N-2) vrijh.grad.  $SS(res)= 0.7835E+00$

De ingevoerde punten zijn:

n	X-waarde	Y-waarde
1	5.950	2.350
2	2.500	0.700
3	5.950	2.050
4	4.200	1.500
5	4.000	1.600
6	2.700	1.000
7	0.750	0.000
8	3.000	1.200
9	3.300	1.250
10	3.100	1.300
11	1.500	0.500
12	1.850	0.700
13	1.700	0.600
14	0.600	0.000
15	2.350	1.000
16	4.850	2.000
17	1.650	0.400
18	3.050	1.050
19	4.500	1.900
20	4.700	2.050
21	4.250	1.800
22	1.400	0.150
23	3.950	1.550
24	4.000	1.600
25	0.900	0.000
26	4.250	1.750
27	3.500	1.650
28	2.100	0.650
29	3.500	1.550
30	3.100	1.150
31	1.850	1.000



$$Y=bX+a$$

$$b= 0.4719E+00$$

$$a=-0.3843E+00$$

$$\text{de correlatiecoefficient} \quad R= 0.8582E+00$$

$$\text{de residuele standaardafwijking} \quad S(y,x)= 0.3516E+00$$

$$\text{de standaardfout in het intercept} \quad S(a)= 0.1722E+00$$

$$\text{de standaardfout in res.coefficient b:} \quad S(b)= 0.5242E-01$$

toetsing voor het intercept a,

$$\text{met (N-2) vrijheidsgraden} \quad t= 0.2232E+01$$

toetsing voor regressiecoefficient b

$$\text{met (N-2) vrijheidsgraden} \quad t= 0.9003E+01$$

de totale Kwadraatsom

$$\text{met (N-1) vrijheidsgraden} \quad SS(y)= 0.1361E+02$$

de Kwadraatsom, toe te schrijven

$$\text{aan de regressievergelijking} \quad SS(res)= 0.1002E+02$$

de Kwadraatsom, toe te schrijven

$$\text{aan afwijkingen van de regressie-} \\ \text{vergelijking met (N-2) vrijh.grad.} \quad SS(res)= 0.3585E+01$$

De ingevoerde punten zijn:

n	X-waarde	Y-waarde
1	4.200	1.800
2	5.050	1.700
3	5.000	1.700
4	2.050	0.500
5	4.400	2.000
6	1.000	0.000
7	2.250	0.750
8	6.100	2.750
9	2.650	1.000
10	4.000	1.650
11	2.500	0.900
12	2.600	1.000
13	1.650	0.300
14	2.850	1.000
15	3.500	1.600
16	1.750	1.100
17	3.750	2.600
18	2.000	0.650
19	1.750	0.400
20	3.500	1.250
21	1.400	0.350
22	2.800	0.600
23	1.750	0.000
24	4.800	1.250
25	3.500	1.000
26	3.300	1.000
27	3.000	1.000
28	2.050	0.400
29	2.800	0.600
30	2.750	0.700
31	4.050	1.250



$$Y=bX+a$$

$$b= 0.3214E+00$$

$$a=-0.4889E+00$$

de correlatiecoëfficiënt  $R= 0.9618E+00$   
 de residuele standaardafwijking  $S(y,x)= 0.9965E-01$   
 de standaardfout in het intercept  $S(a)= 0.6277E-01$   
 de standaardfout in res.coëfficiënt b:  $S(b)= 0.1728E-01$   
 toetsing voor het intercept a,  
 met (N-2) vrijheidsgraden  $t= 0.7790E+01$   
 toetsing voor regressiecoëfficiënt b  
 met (N-2) vrijheidsgraden  $t= 0.1860E+02$   
 de totale kwadraatsom  
 met (N-1) vrijheidsgraden  $SS(y)= 0.3713E+01$   
 de kwadraatsom, toe te schrijven  
 aan de regressievergelijking  $SS(res)= 0.3435E+01$   
 de kwadraatsom, toe te schrijven  
 aan afwijkingen van de regressie-  
 vergelijking met (N-2) vrijh.grad.  $SS(res)= 0.2781E+00$

De ingevoerde punten zijn:

n	X-waarde	Y-waarde
1	2.850	0.300
2	4.650	1.100
3	4.050	0.950
4	4.050	0.800
5	2.850	0.400
6	2.500	0.250
7	4.050	0.900
8	3.250	0.600
9	1.600	0.000
10	2.600	0.400
11	3.000	0.450
12	3.100	0.550
13	3.750	0.800
14	2.600	0.300
15	2.950	0.450
16	1.600	0.000
17	3.200	0.600
18	5.000	1.150
19	4.150	0.850
20	3.900	0.800
21	3.750	0.800
22	5.000	1.200
23	5.900	1.350
24	3.000	0.250
25	5.200	1.000
26	4.100	0.550
27	3.650	0.750
28	1.300	0.000
29	3.600	0.700
30	3.100	0.600



$$Y = bX + a$$

$$b = 0.2486E+00$$

$$a = -0.4457E+00$$

de correlatiecoëfficiënt	R = 0.8611E+00
de residuele standaardafwijking	S(y,x) = 0.1763E+00
de standaardfout in het intercept	S(a) = 0.9980E-01
de standaardfout in res.coëfficiënt b:	S(b) = 0.2726E-01
toetsing voor het intercept a, met (N-2) vrijheidsgraden	t = 0.4465E+01
toetsing voor regressiecoëfficiënt b met (N-2) vrijheidsgraden	t = 0.9122E+01
de totale Kwadraatsom met (N-1) vrijheidsgraden	SS(y) = 0.3488E+01
de Kwadraatsom, toe te schrijven aan de regressievergelijking	SS(res) = 0.2586E+01
de Kwadraatsom, toe te schrijven aan afwijkingen van de regressie- vergelijking met (N-2) vrijh.grad.	SS(res) = 0.9013E+00

De ingevoerde punten zijn:

n	X-waarde	Y-waarde
1	3.100	0.200
2	2.950	0.050
3	2.750	0.100
4	1.900	0.000
5	2.150	0.000
6	2.950	0.450
7	1.950	0.200
8	2.900	0.400
9	3.750	0.600
10	2.500	0.200
11	4.000	0.700
12	2.100	0.000
13	4.300	0.800
14	1.600	0.000
15	4.500	1.000
16	2.150	0.200
17	5.450	1.100
18	3.500	0.500
19	5.250	1.050
20	3.650	0.600
21	4.100	0.750
22	5.600	1.000
23	5.700	0.700
24	4.750	0.500
25	2.400	0.000
26	3.650	0.450
27	3.150	0.350
28	4.000	0.250
29	4.700	0.400
30	4.000	0.300
31	2.200	0.100





$$Y=bX+a$$

$$b= 0.4136E+00$$

$$a=-0.6504E+00$$

$$\text{de correlatiecoefficient} \quad R= 0.9819E+00$$

$$\text{de residuale standaardafwijking} \quad S(y,x)= 0.1092E+00$$

$$\text{de standaardfout in het intercept} \quad S(a)= 0.6222E-01$$

$$\text{de standaardfout in res.coefficient b:} \quad S(b)= 0.1506E-01$$

$$\text{toetsing voor het intercept a,} \\ \text{met (N-2) vrijheidsgraden} \quad t= 0.1045E+02$$

$$\text{toetsing voor regressiecoefficient b} \\ \text{met (N-2) vrijheidsgraden} \quad t= 0.2746E+02$$

$$\text{de totale Kwadraatsom} \\ \text{met (N-1) vrijheidsgraden} \quad SS(y)= 0.9327E+01$$

$$\text{de Kwadraatsom, toe te schrijven} \\ \text{aan de regressievergelijking} \quad SS(\text{res})= 0.8994E+01$$

$$\text{de Kwadraatsom, toe te schrijven} \\ \text{aan afwijkingen van de regressie-} \\ \text{vergelijking met (N-2) vrijh.grad.} \quad SS(\text{res})= 0.3339E+00$$

De ingevoerde punten zijn:

n	X-waarde	Y-waarde
1	3.350	0.700
2	3.100	0.600
3	4.500	1.300
4	4.750	1.300
5	1.650	0.000
6	3.700	0.800
7	1.600	0.000
8	4.600	1.200
9	4.700	1.400
10	4.250	1.150
11	1.850	0.100
12	5.900	1.650
13	4.150	0.950
14	2.600	0.150
15	5.500	1.500
16	5.000	1.200
17	5.000	1.400
18	4.650	1.200
19	3.250	0.850
20	4.550	1.250
21	5.300	1.500
22	4.150	1.250
23	1.600	0.050
24	4.150	1.100
25	5.500	1.650
26	2.000	0.100
27	4.500	1.300
28	5.100	1.600
29	1.450	0.150
30	5.000	1.450



$Y=bX+a$

$b= 0.4800E+00$

$a=-0.4935E+00$

de correlatiecoefficient  $R= 0.9914E+00$

de residuele standaardafwijking  $S(y,x)= 0.9774E-01$

de standaardfout in het intercept  $S(a)= 0.4054E-01$

de standaardfout in res.coefficient b:  $S(b)= 0.1177E-01$

toetsins voor het intercept a,  
met (N-2) vrijheidsgraden  $t= 0.1217E+02$

toetsins voor resressiecoefficient b  
met (N-2) vrijheidsgraden  $t= 0.4078E+02$

de totale kwadraatsom  
met (N-1) vrijheidsgraden  $SS(y)= 0.1616E+02$

de kwadraatsom, toe te schrijven  
aan de resressieverselijking  $SS(res)= 0.1588E+02$

de kwadraatsom, toe te schrijven  
aan afwijkingen van de resressie-

verselijking met (N-2) vrijh.grad.  $SS(res)= 0.2770E+00$

De insevoerde punten zijn:

n	X-waarde	Y-waarde
1	3.000	1.100
2	4.800	1.850
3	3.600	1.200
4	1.050	0.000
5	2.000	0.500
6	1.700	0.350
7	5.450	2.300
8	3.750	1.300
9	2.650	0.850
10	4.150	1.600
11	1.400	0.050
12	6.600	2.700
13	4.700	1.650
14	3.100	1.000
15	1.750	0.450
16	1.250	0.000
17	4.400	1.500
18	3.100	0.850
19	2.000	0.350
20	1.100	0.000
21	2.150	0.700
22	3.400	1.250
23	1.200	0.000
24	5.100	1.850
25	1.500	0.300
26	2.850	1.000
27	5.500	2.000
28	2.000	0.450
29	4.000	1.400
30	2.500	0.700
31	4.500	1.650



$$Y=bX+a$$

$$b= 0.6835E+00$$

$$a=-0.4853E+00$$

de correlatiecoefficient  $R= 0.9960E+00$

de residuele standaardafwijking  $S(y,x)= 0.1184E+00$

de standaardfout in het intercept  $S(a)= 0.4139E-01$

de standaardfout in res.coefficient b:  $S(b)= 0.1140E-01$

toetsins voor het intercept a,

met (N-2) vrijheidsgraden  $t= 0.1172E+02$

toetsins voor regressiecoefficient b

met (N-2) vrijheidsgraden  $t= 0.5996E+02$

de totale Kwadraatsom

met (N-1) vrijheidsgraden  $SS(y)= 0.5084E+02$

de kwadraatsom, toe te schrijven

aan de regressievervelijking  $SS(res)= 0.5043E+02$

de kwadraatsom, toe te schrijven

aan afwijkingen van de regressie-  
vervelijking met (N-2) vrijh.grad.  $SS(res)= 0.4068E+00$

De insevoerde punten zijn:

n	X-waarde	Y-waarde
1	4.050	2.300
2	3.350	1.850
3	0.750	0.000
4	0.800	0.250
5	5.750	3.450
6	1.350	0.250
7	3.000	1.700
8	1.000	0.350
9	2.100	1.000
10	3.650	2.200
11	5.250	3.200
12	4.150	2.500
13	4.650	2.650
14	0.600	0.050
15	1.250	0.200
16	5.750	3.450
17	4.950	2.700
18	1.350	0.450
19	2.150	1.000
20	5.450	3.250
21	4.850	2.900
22	1.850	0.650
23	6.100	3.650
24	2.100	0.800
25	6.350	3.800
26	4.100	2.150
27	1.800	0.750
28	1.050	0.350
29	1.250	0.300
30	4.750	2.800
31	1.000	0.000

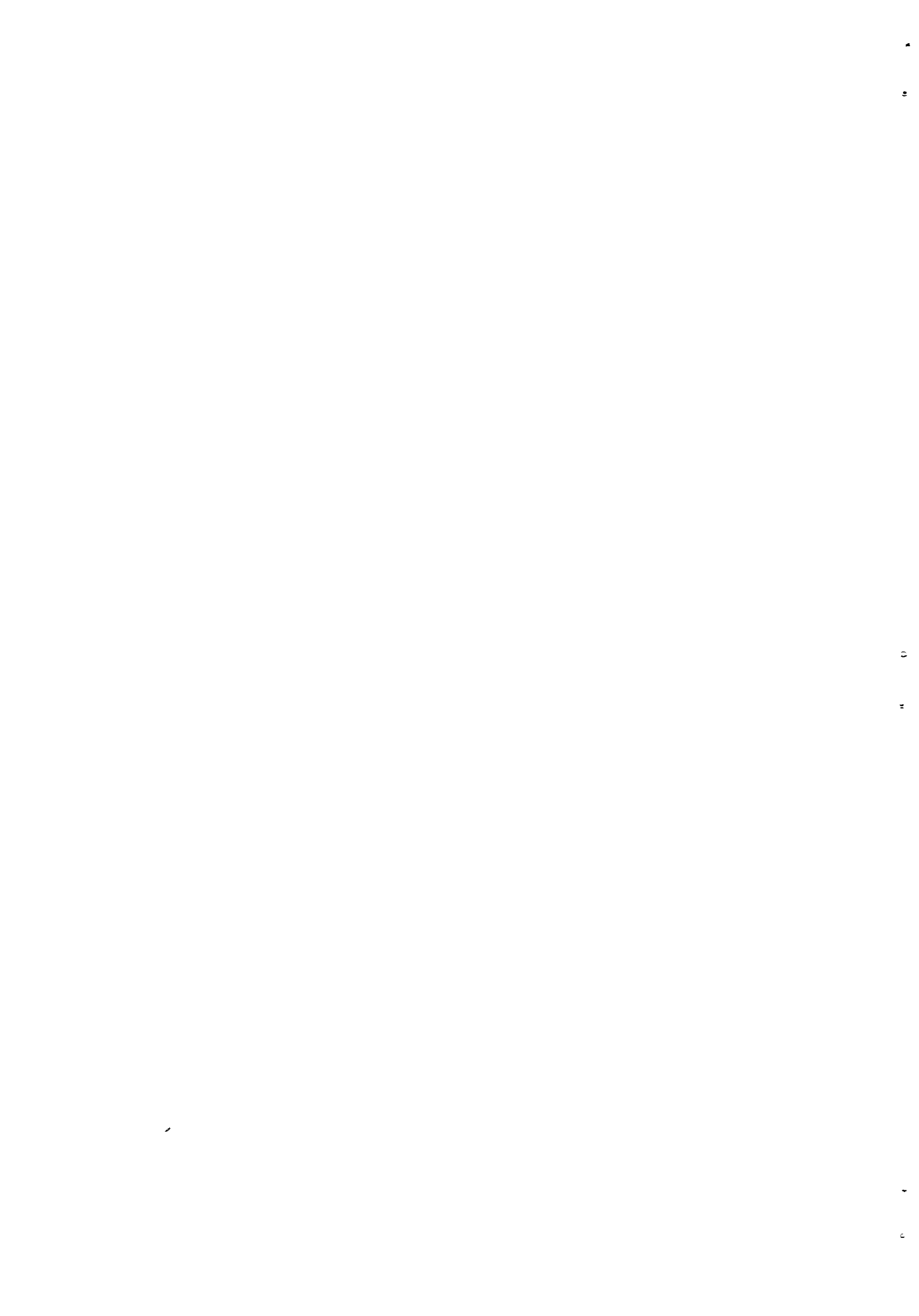

$$Y = bX + a$$

$$b = 0.4844E+00$$

$$a = -0.3885E+00$$

de correlatiecoëfficiënt  $R = 0.9883E+00$   
 de residuele standaardafwijking  $S(y,x) = 0.1231E+00$   
 de standaardfout in het intercept  $S(a) = 0.4406E-01$   
 de standaardfout in res.coëfficiënt b:  $S(b) = 0.1368E-01$   
 toetsing voor het intercept a,  
 met (N-2) vrijheidsgraden  $t = 0.8817E+01$   
 toetsing voor regressiecoëfficiënt b  
 met (N-2) vrijheidsgraden  $t = 0.3542E+02$   
 de totale kwadraatsom  
 met (N-1) vrijheidsgraden  $SS(y) = 0.1946E+02$   
 de kwadraatsom, toe te schrijven  
 aan de regressievergelijking  $SS(res) = 0.1901E+02$   
 de kwadraatsom, toe te schrijven  
 aan afwijkingen van de regressie-  
 vergelijking met (N-2) vrijh.grad.  $SS(res) = 0.4545E+00$

De ingevoerde punten zijn:

n	X-waarde	Y-waarde
1	4.200	1.650
2	1.300	0.000
3	3.800	1.450
4	4.950	1.950
5	2.900	0.950
6	4.000	1.550
7	1.500	0.100
8	5.000	2.000
9	1.100	0.100
10	3.250	1.150
11	1.650	0.500
12	3.150	0.900
13	0.800	0.000
14	1.250	0.050
15	4.200	1.850
16	1.000	0.100
17	3.250	1.250
18	1.100	0.200
19	0.800	0.000
20	2.350	0.800
21	5.000	2.150
22	6.100	2.400
23	1.500	0.550
24	4.700	1.900
25	5.950	2.550
26	1.350	0.400
27	3.600	1.300
28	1.600	0.400
29	2.300	0.650
30	3.250	1.400
31	1.150	0.300
32	1.600	0.450





$Y = bX + a$   
 $b = 0.6566E+00$   
 $a = -0.5075E+00$   
 de correlatiecoefficient  $R = 0.9767E+00$   
 de residuele standaardafwijking  $S(y,x) = 0.2482E+00$   
 de standaardfout in het intercept  $S(a) = 0.9951E-01$   
 de standaardfout in res.coefficient b:  $S(b) = 0.2634E-01$   
 toetsing voor het intercept a,  
 met (N-2) vrijheidsgraden  $t = 0.5100E+01$   
 toetsing voor regressiecoefficient b  
 met (N-2) vrijheidsgraden  $t = 0.2493E+02$   
 de totale Kwadraatsom  $SS(y) = 0.4012E+02$   
 met (N-1) vrijheidsgraden  
 de Kwadraatsom, toe te schrijven  
 aan de regressieveraelijkings  $SS(res) = 0.3828E+02$   
 de Kwadraatsom, toe te schrijven  
 aan afwijkingen van de regressie-  
 veraelijkings met (N-2) vrijh.grad.  $SS(res) = 0.1848E+01$

De insevoerde punten zijn:

n	X-waarde	Y-waarde
1	1.850	0.750
2	4.750	2.750
3	1.100	0.300
4	4.600	2.400
5	2.100	0.800
6	4.700	2.800
7	1.600	0.500
8	2.250	0.850
9	2.400	1.000
10	2.100	0.750
11	5.500	3.350
12	3.250	1.400
13	1.500	0.350
14	2.600	1.150
15	5.250	3.100
16	2.000	0.950
17	1.500	0.600
18	4.650	2.600
19	3.850	1.800
20	3.000	1.650
21	2.500	1.150
22	1.450	0.350
23	5.100	2.900
24	3.000	0.800
25	1.850	0.700
26	6.600	4.200
27	5.950	3.550
28	2.350	1.150
29	6.500	3.100
30	2.100	1.400
31	6.100	3.250
32	4.450	2.600



$Y=bX+a$

$b= 0.4291E+00$

$a=-0.4957E+00$

de correlatiecoefficient  $R= 0.9614E+00$

de residuele standaardafwijking  $S(y,x)= 0.1182E+00$

de standaardfout in het intercept  $S(a)= 0.5967E-01$

de standaardfout in res.coefficient b:  $S(b)= 0.2320E-01$

toetsins voor het intercept a,  
met (N-2) vrijheidsgraden  $t= 0.8308E+01$

toetsins voor resressiecoefficient b  
met (N-2) vrijheidsgraden  $t= 0.1850E+02$

de totale Kwadraatsom  
met (N-1) vrijheidsgraden  $SS(y)= 0.5172E+01$

de Kwadraatsom, toe te schrijven  
aan de resressieverselijking  $SS(res)= 0.4780E+01$

de Kwadraatsom, toe te schrijven  
aan afwijkingen van de resressie-  
verselijking met (N-2) vrijh.grad.  $SS(res)= 0.3912E+00$

De insevoerde punten zijn:

n	X-waarde	Y-waarde
1	2.500	0.850
2	2.450	0.650
3	1.900	0.250
4	1.300	0.000
5	2.600	0.700
6	1.050	0.000
7	1.600	0.150
8	2.150	0.550
9	2.150	0.450
10	1.150	0.000
11	2.750	0.800
12	2.250	0.500
13	2.350	0.600
14	2.050	0.250
15	2.750	0.600
16	3.750	1.050
17	2.350	0.600
18	2.450	0.650
19	2.750	0.550
20	0.850	0.000
21	1.350	0.000
22	3.250	0.700
23	3.600	0.850
24	1.350	0.000
25	3.750	1.250
26	5.000	1.750
27	3.600	1.000
28	2.400	0.600
29	1.500	0.000
30	3.000	0.650

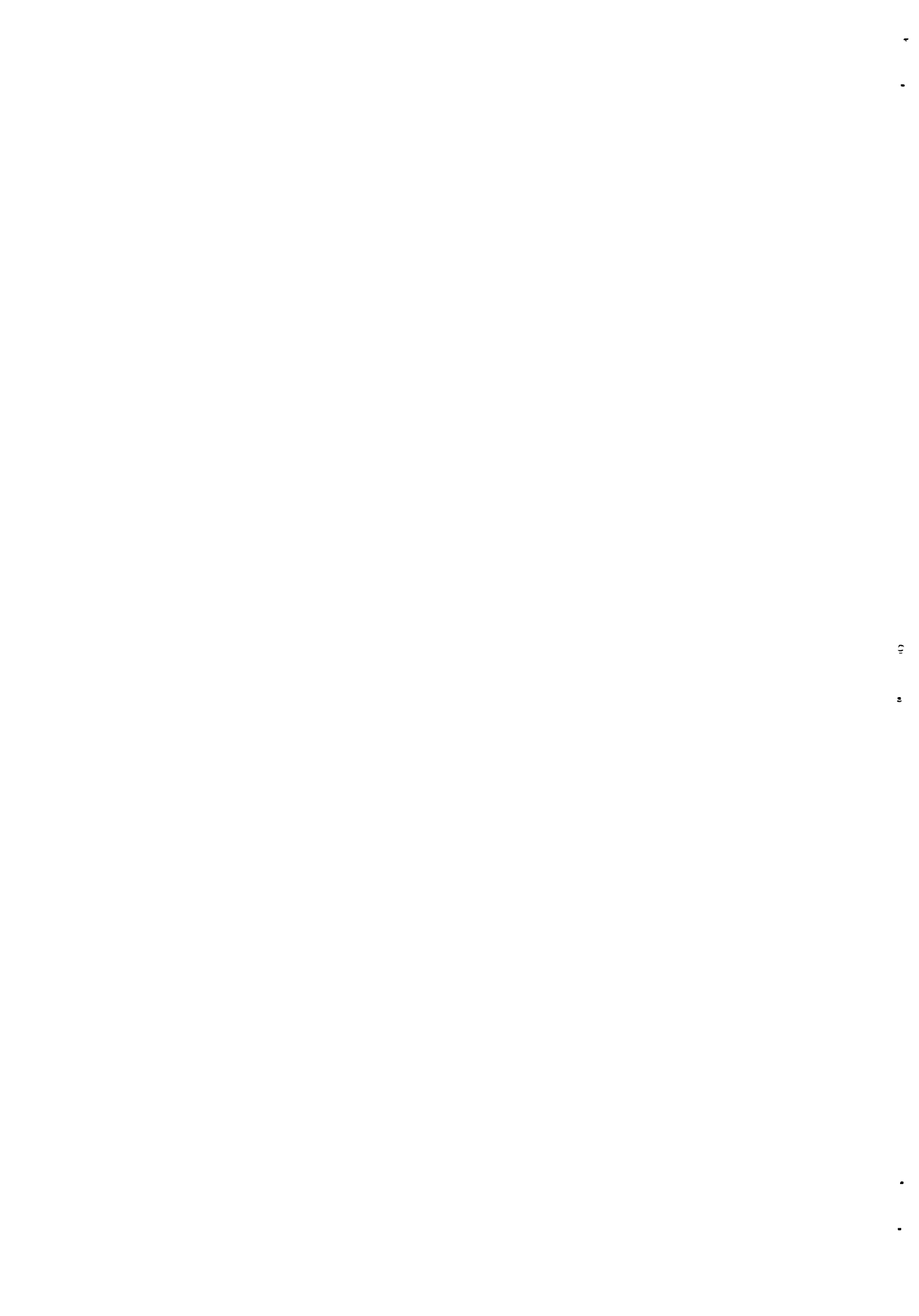

## List of references

01

- 01 IHVE Guide -The institution of Heating and Ventilating Engineers London, 1972 Book A,B and C (T.H.D.)
- 02 Physikhütte -Band 1, Mechanik 29. Auflage
- 03 ir.L.A.van de Putte -Stroming en Warmteoverdracht I Delft 1976
- 04 Gauger R.und Schüle W--Lüftungsanlagen im Wohnungsbau  
FBW (veröffentlichung der Forschungsgemeinschaft Bauen und Wohnen) Stuttgart Oktober 1958
- 05 Alink A en Veldkamp RG-Lineaire Regressie, uit handleiding voor TI 54  
Lab. Gezondheidstechniek juni 1980
- 06 Ashworth J. -The Dar es Salaam ventilated improved pit latrine demonstration project.  
Ministry of Lands, Housing and Urban Development  
Dar es Salaam, February 1981, Tanzania.
- 07 Kalbermatten John M. -De Anne S.Julius and Charles G.Gunnerson Appropriate Technology for Water Supply and Sanitation  
Vol.1 Technical and Economic Options  
World Bank December 1980
- 08 Curtis C.F. and P.M. Hawkins -Entomological studies of on-site sanitation systems in Botswana and Tanzania.  
Transactions of the Royal Society of Tropical Medicine and Hygiene, Vol.76, No.1, 1982.
- 09 -NEN 1087 December 1975  
Ventilatie van woongebouwen
- 10 -BS 5925: 1980 British Standards Institution Design of buildings: ventilation principles and designing for natural ventilation.
- 11 -IS: 3362 - 1965 Indian Standards Institution Code of practice for natural ventilation of residential buildings.
- 12 -AS 1668, Part 2-1980 Australian Standards SAA Mechanical Ventilation and Airconditioning Code Part 2 Ventilation Requirements.
- 13 Terje Bodoegaard -Climate and Design in Tanzania  
Guidelines for rural housing  
B.R.U. - Ardhi Ministry Dar es Salaam 1981



List of references

02

- 14 Roedler F. - Zur Problematik der Lüftung innenliegender Aborte und Bäder im sozialen Wohnungsbau. Ges. Ing. 72 (1951, Nr 1/2, S. 8 und Nr.4, S.58
- 15 Back O. - Die Ermittlung der relativen Wertigkeit windbetätigter Saughauben. Ges.-Ing. 55 (1932), Nr.51 S.607
- 16 de Voogd und Wirtz - Betrachtungen über das Verhalten von Schornsteinaufsätzen bei Wind und Regen Ges.-Ing. 59 (1936) Nr. 42, S.605 u.Nr.43,S621
- 17 ter Linden - Schornstein- und Lüftungsaufsätze. Ges. Ing. 62 (1939) S.221
- 18 H. Föttinger - Strömung in dampfkesselanlagen VGB Heft 73 10 sept. 1939
- 19 W.G. Cornell - Losses in flow normal to plane screens Transactions of the American Society of Mechanical Eng. 80 (4) 791-799 (1958)
- 20 L.P.Box, W.G.Hunter - J. Stuart Hunter Statistics for experimenters An introduction to Design, Data analysis, and Model Building. 1978 J. Wiley and Sons, Inc.





## Day-programme and weather conditions

The measurements took place on the following days.

Date :	Measurements :
Tuesday 3 Aug. 1982	A1 A2 A3 A4 A5
Wednesday 4 Aug. 1982	A6 A7 A8 A9
Thursday 5 Aug. 1982	B1 B2 D1 B3
Friday 6 Aug. 1982	B6 B5 D2 B4 B8 D4
Monday 9 Aug. 1982	D3 C2 C1 C3
Tuesday 10 Aug. 1982	B7 B9 B10 B11
Wednesday 11 Aug. 1982	D5 B12

The weather conditions are constant during all days.

Clouds covering most of the sky, reasonable wind, no rain (during the measurements) and a temperature of  $25\text{ C}^{\circ} \pm 2$ .

The measurements took place during day-time, starting from 9.30 hr.

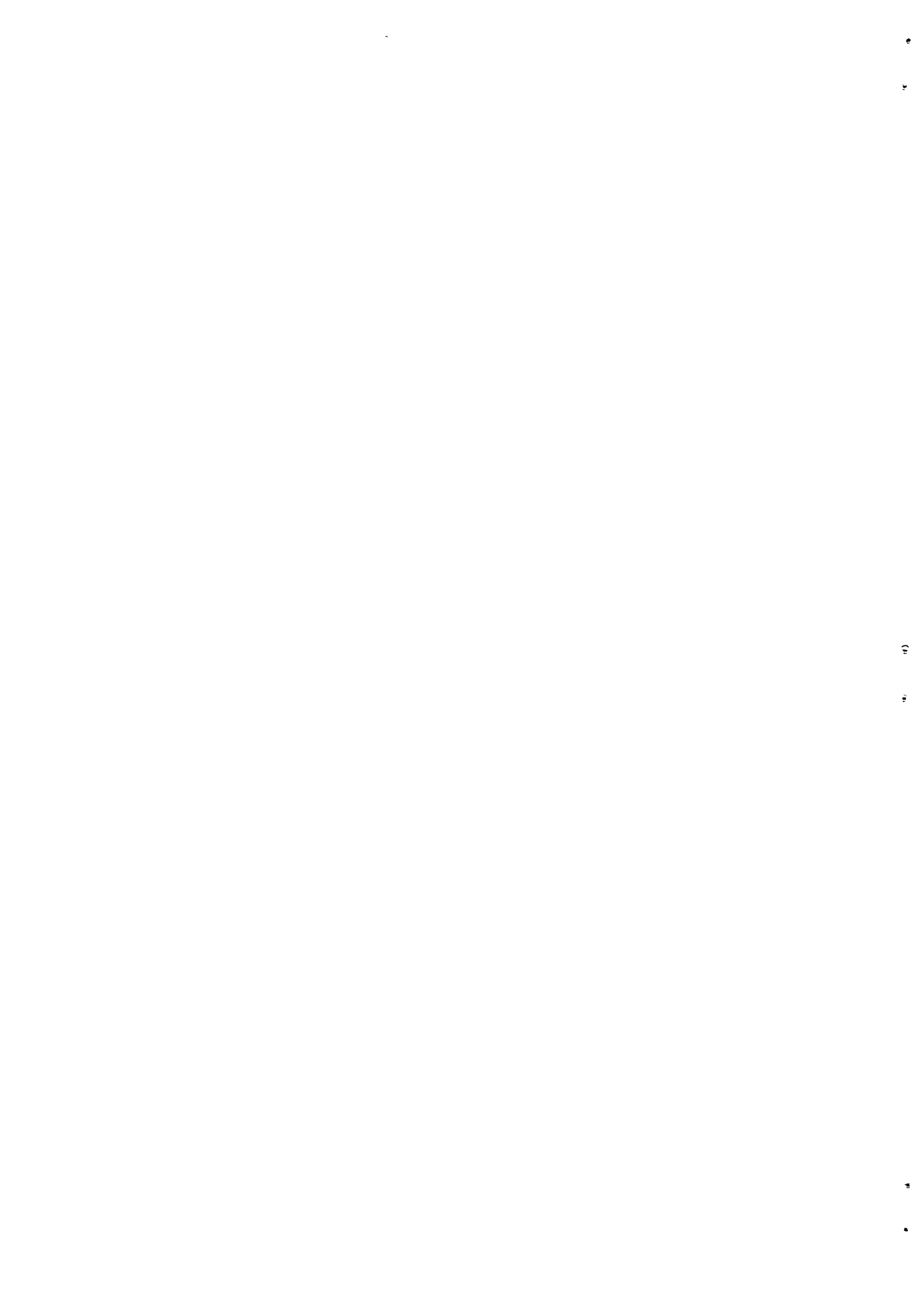

## List of equipment

## 1. Portable Anemograph; Vector Instruments type R500

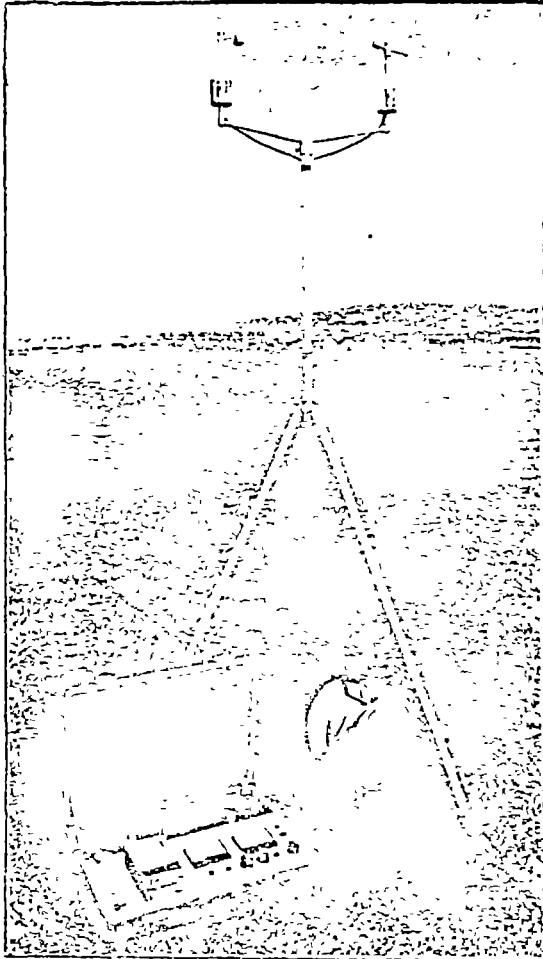

Description: A fully portable equipment for indicating and recording wind speed and direction. Included are a Porton Anemometer, Porton Windvane, mounting arm with taper fittings, and a meter display and recording equipment built into a carrying case.

Wind speed and direction are displayed on two panel meters and the same values are also recorded on the two channels of a miniature strip chart recorder. Three way filter switches are provided for selecting the required averaging period for display meter and recorder, and a calibration facility allows meter and recorder indications to be set to reference values before use and re-checked after a recording session.

The equipment is powered by a mains re-chargeable battery supply.

Accuracy: Speed:  $\pm 2\frac{1}{2}\%$  ( $\pm 0.25$  m/s below 10 m/s)

Direction:  $\pm 3\%$

Filter averaging times: Position 10: 10 sec.  $\pm 20\%$

Chart speed: 3.0 inches/hour  $\pm 2\%$

Range of measurement: Speed: Range 1: 0-10m/s in 0.2m/s divisions.

Direction:  $600^\circ$  Scale in  $10^\circ$  divisions.

## 2. Micromanometer; Furness Controls Ltd PFFA - FC060

Components: Measuring head -pitot-tube

Micromanometer -sensitive pressure measuring unit with a total range of 10,000 : 1 to an accuracy of 1% in any range.



Flow Ranges:      100% Flow =    9 m/s    =   5 mm H<sub>2</sub>O  
                         10% Flow =    0.9 m/s    0.05 mm H<sub>2</sub>O

The fast-slow meter switch gives a time constant for turbulent flow (slow position gives 5 seconds)

The equipment is powered by a mains re-chargeable battery supply.

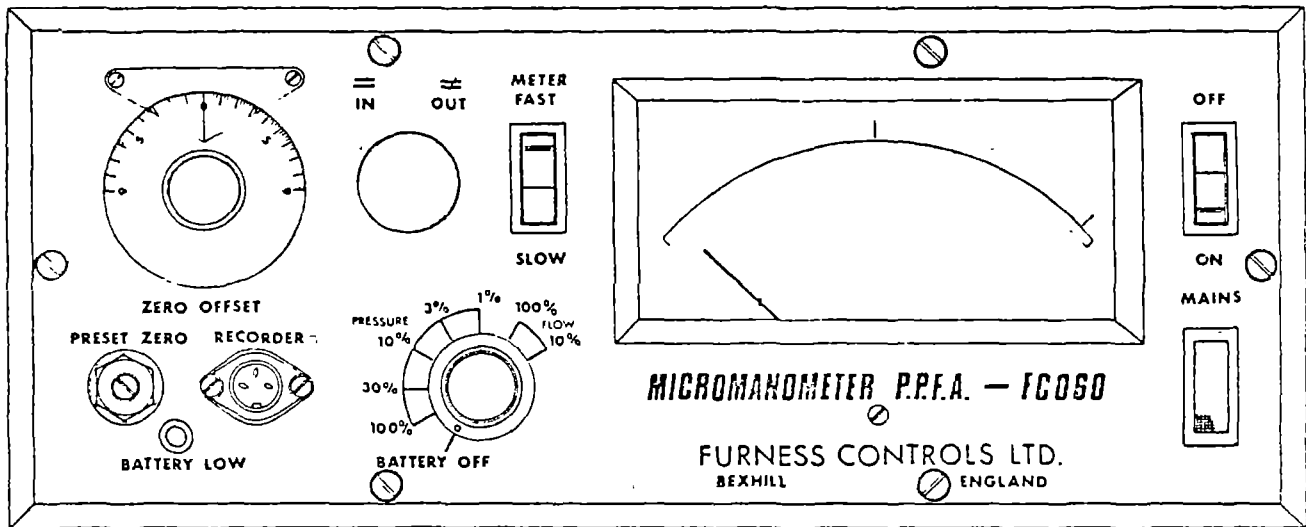

### 3. Recorder; Rustrak 200, Gulton

The recorder is connected to the micromanometer. Calibration facility allows recorder indication to be set to reference value.  
Chart speed: 6.0 inches/hour.

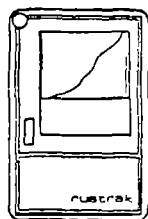

200

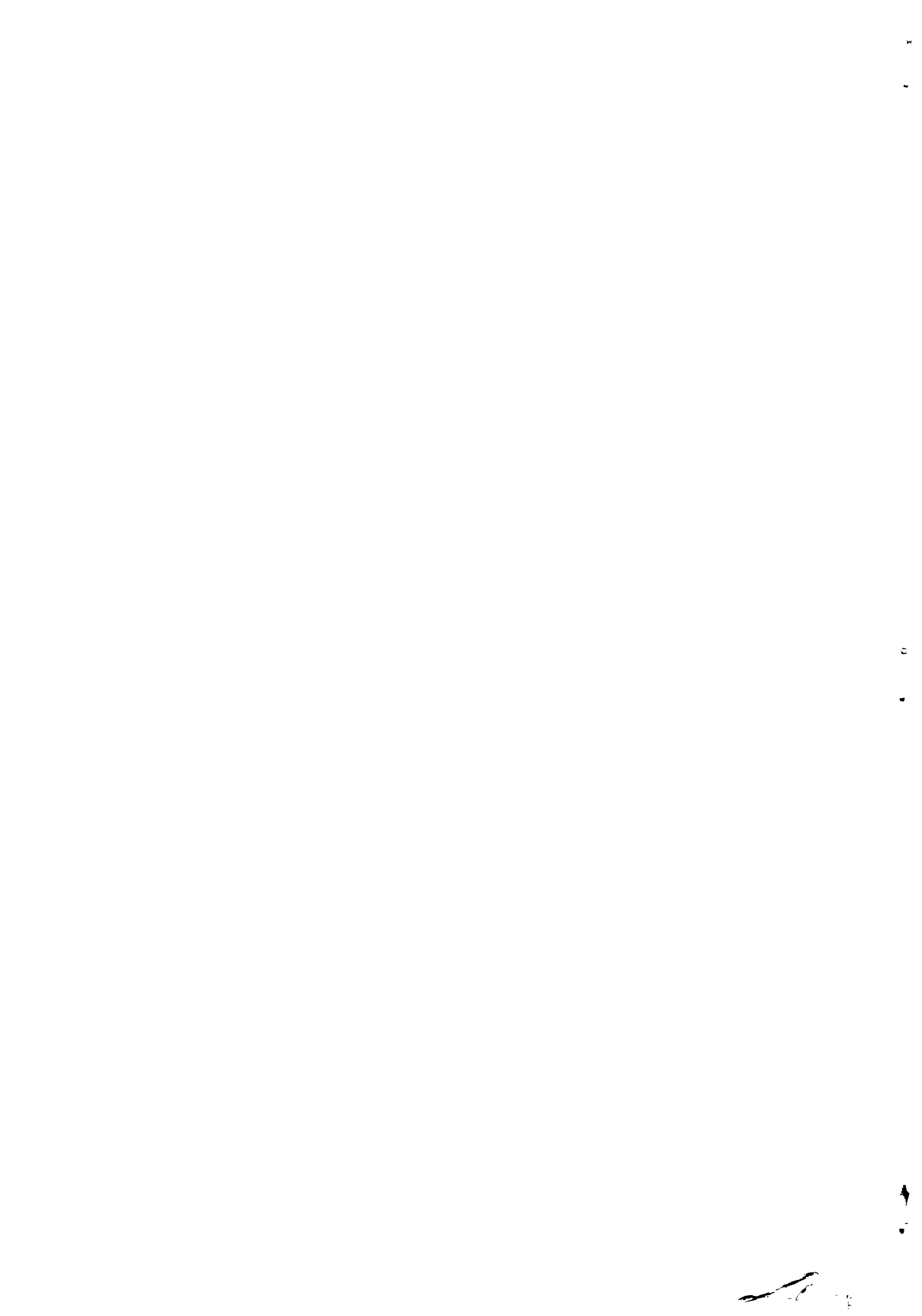

THE DISTRIBUTION OF  $t^*$  (TWO-TAILED TESTS)

Degrees of Freedom	Probability of a Larger Value, Sign Ignored								
	0.500	0.400	0.200	0.100	0.050	0.025	0.010	0.005	0.001
1	1.000	1.376	3.078	6.314	12.706	25.452	63.657		
2	0.816	1.061	1.886	2.920	4.303	6.205	9.925	14.089	31.598
3	0.765	0.978	1.638	2.353	3.182	4.176	5.841	7.453	12.941
4	0.741	0.941	1.533	2.132	2.776	3.495	4.604	5.598	8.610
5	0.727	0.920	1.476	2.015	2.571	3.163	4.032	4.773	6.859
6	0.718	0.906	1.440	1.943	2.447	2.969	3.707	4.317	5.959
7	0.711	0.896	1.415	1.895	2.365	2.841	3.499	4.029	5.405
8	0.706	0.889	1.397	1.860	2.306	2.752	3.355	3.832	5.041
9	0.703	0.883	1.383	1.833	2.262	2.685	3.250	3.690	4.781
10	0.700	0.879	1.372	1.812	2.228	2.634	3.169	3.581	4.587
11	0.697	0.876	1.363	1.796	2.201	2.593	3.106	3.497	4.437
12	0.695	0.873	1.356	1.782	2.179	2.560	3.055	3.428	4.318
13	0.694	0.870	1.350	1.771	2.160	2.533	3.012	3.372	4.221
14	0.692	0.868	1.345	1.761	2.145	2.510	2.977	3.326	4.140
15	0.691	0.866	1.341	1.753	2.131	2.490	2.947	3.286	4.073
16	0.690	0.865	1.337	1.746	2.120	2.473	2.921	3.252	4.015
17	0.689	0.863	1.333	1.740	2.110	2.458	2.898	3.222	3.965
18	0.688	0.862	1.330	1.734	2.101	2.445	2.878	3.197	3.922
19	0.688	0.861	1.328	1.729	2.093	2.433	2.861	3.174	3.883
20	0.687	0.860	1.325	1.725	2.086	2.423	2.845	3.153	3.850
21	0.686	0.859	1.323	1.721	2.080	2.414	2.831	3.135	3.819
22	0.686	0.858	1.321	1.717	2.074	2.406	2.819	3.119	3.792
23	0.685	0.858	1.319	1.714	2.069	2.398	2.807	3.104	3.767
24	0.685	0.857	1.318	1.711	2.064	2.391	2.797	3.090	3.745
25	0.684	0.856	1.316	1.708	2.060	2.385	2.787	3.078	3.725
26	0.684	0.856	1.315	1.706	2.056	2.379	2.779	3.067	3.707
27	0.684	0.855	1.314	1.703	2.052	2.373	2.771	3.056	3.690
28	0.683	0.855	1.313	1.701	2.048	2.368	2.763	3.047	3.674
29	0.683	0.854	1.311	1.699	2.045	2.364	2.756	3.038	3.659
30	0.683	0.854	1.310	1.697	2.042	2.360	2.750	3.030	3.646
35	0.682	0.852	1.306	1.690	2.030	2.342	2.724	2.996	3.591
40	0.681	0.851	1.303	1.684	2.021	2.329	2.704	2.971	3.551
45	0.680	0.850	1.301	1.680	2.014	2.319	2.690	2.952	3.520
50	0.680	0.849	1.299	1.676	2.008	2.310	2.678	2.937	3.496
55	0.679	0.849	1.297	1.673	2.004	2.304	2.669	2.925	3.476
60	0.679	0.848	1.296	1.671	2.000	2.299	2.660	2.915	3.460
70	0.678	0.847	1.294	1.667	1.994	2.290	2.648	2.899	3.435
80	0.678	0.847	1.293	1.665	1.989	2.284	2.638	2.887	3.416
90	0.678	0.846	1.291	1.662	1.986	2.279	2.631	2.878	3.402
100	0.677	0.846	1.290	1.661	1.982	2.276	2.625	2.871	3.390
120	0.677	0.845	1.289	1.658	1.980	2.270	2.617	2.860	3.373
$\infty$	0.6745	0.8416	1.2816	1.6448	1.9600	2.2414	2.5758	2.8070	3.2905

\* Parts of this table are reprinted by permission from R. A. Fisher's *Statistical Methods for Research Workers*, published by Oliver and Boyd, Edinburgh (1925-1950) from Maxine Merrington's "Table of Percentage Points of the  $t$ -Distribution," *Biometrika*, 32, 300 (1942), and from Bernard Ostle's *Statistics in Research*, Iowa State University Press (1954).



