

86/7270

321.4
87 BU

Building and Operating Multi-compartment VIP Latrines

by Peter W. S. Lochery and Seth T. Adu-Asah

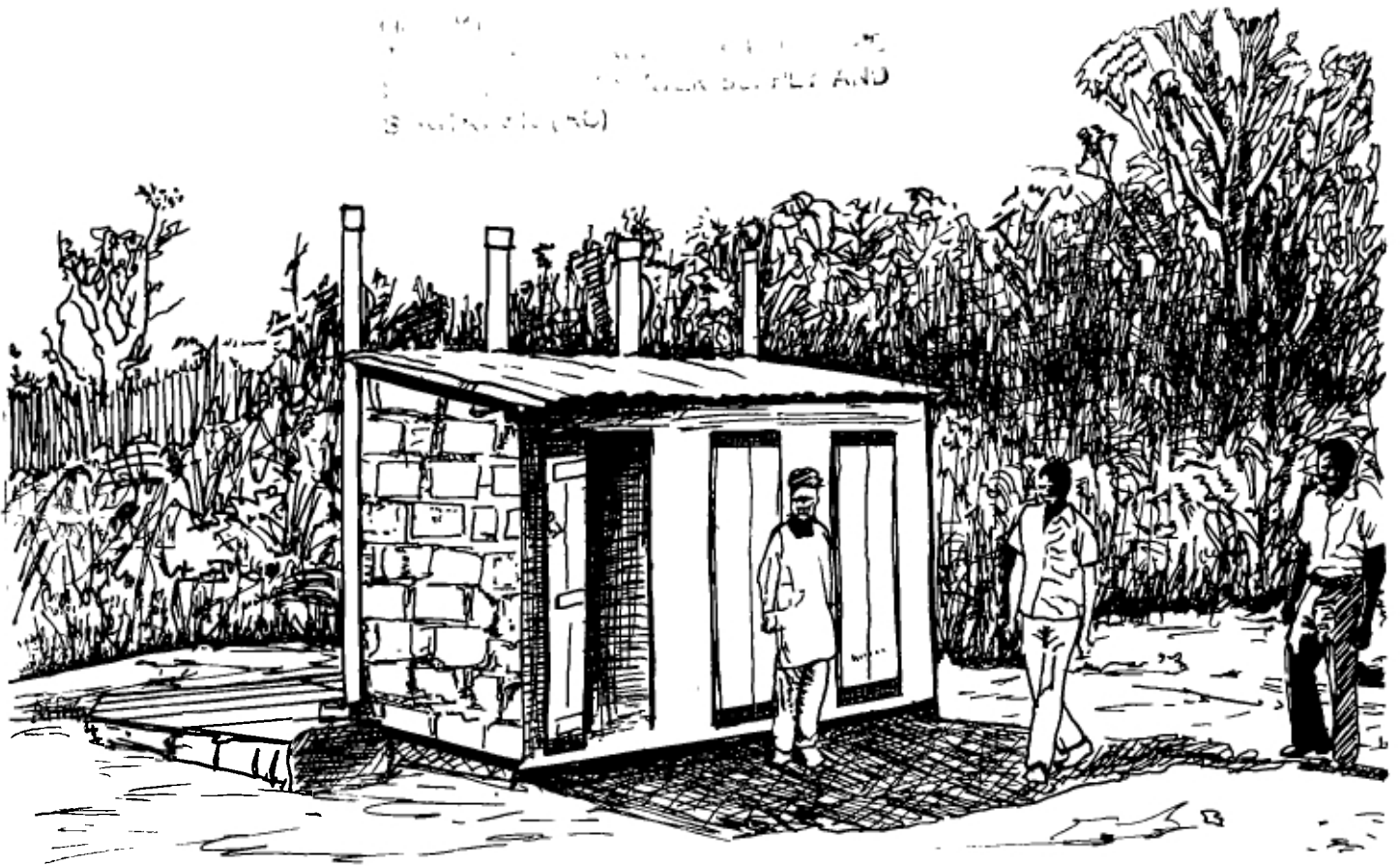

A joint contribution of the Government of Nigeria, The United Nations,
Development Programme, and The World Bank to the International
Drinking Water Supply and Sanitation Decade.



321.4-7270

FOREWORD

This manual provides administrators, building engineers, and technicians with construction, operation, and maintenance procedures for multi-compartment alternating VIP latrines. It was developed by the Federal Ministry of Health through a UNDP project of assistance (NIR/85/070) executed by the World Bank.

The design of the multi-compartment VIP latrine was introduced into Nigeria in 1983 by the World Bank and promoted by UNICEF in Lagos, Cross River, and Imo States. It has now been accepted by many government agencies and non-governmental organizations as an institutional or public latrine for locations where there is no dependable supply of piped water.

Any comments and suggestions on this manual and, in particular, recommended improvements in design and information on costs of construction and operation should be sent to the Chief Consultant, Environmental and Occupational Health Division, Federal Ministry of Health, 8 Harvey Road, Yaba, Lagos.

Professor Olikoye Ransome-Kuti
Minister, Federal Ministry of Health

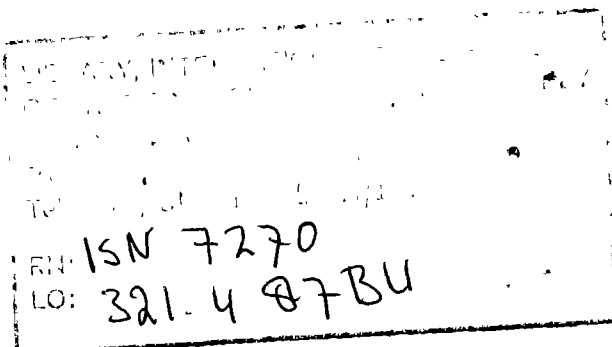

ACKNOWLEDGMENTS

The authors wish to thank UNICEF for the use of their word processor and David Beckleys for his production of the sketches and figures.

This manual was originally prepared by the authors as an aid to trainers in latrine construction. Its wider distribution does not imply endorsement by Federal and State Governments or by the international agencies that have assisted in its production.

WHO CAN THIS MANUAL HELP?

The multi-compartment ventilated improved pit. latrine has been used successfully in Nigeria as a public latrine at markets, motor parks, and in urban areas and also in schools, colleges, and health clinics where there is no dependable supply of piped water.

Part 1 of the manual explains how a multi-compartment alternating VIP latrine works, where it is appropriate to build, its approximate cost, and its operation and maintenance.

Part 2 gives detailed instructions on how to build the latrine, followed by a set of working drawings. Construction of a multi-compartment VIP latrine requires a sound knowledge of building techniques: decisionmakers and administrators need to have people with this expertise available before planning and starting construction.

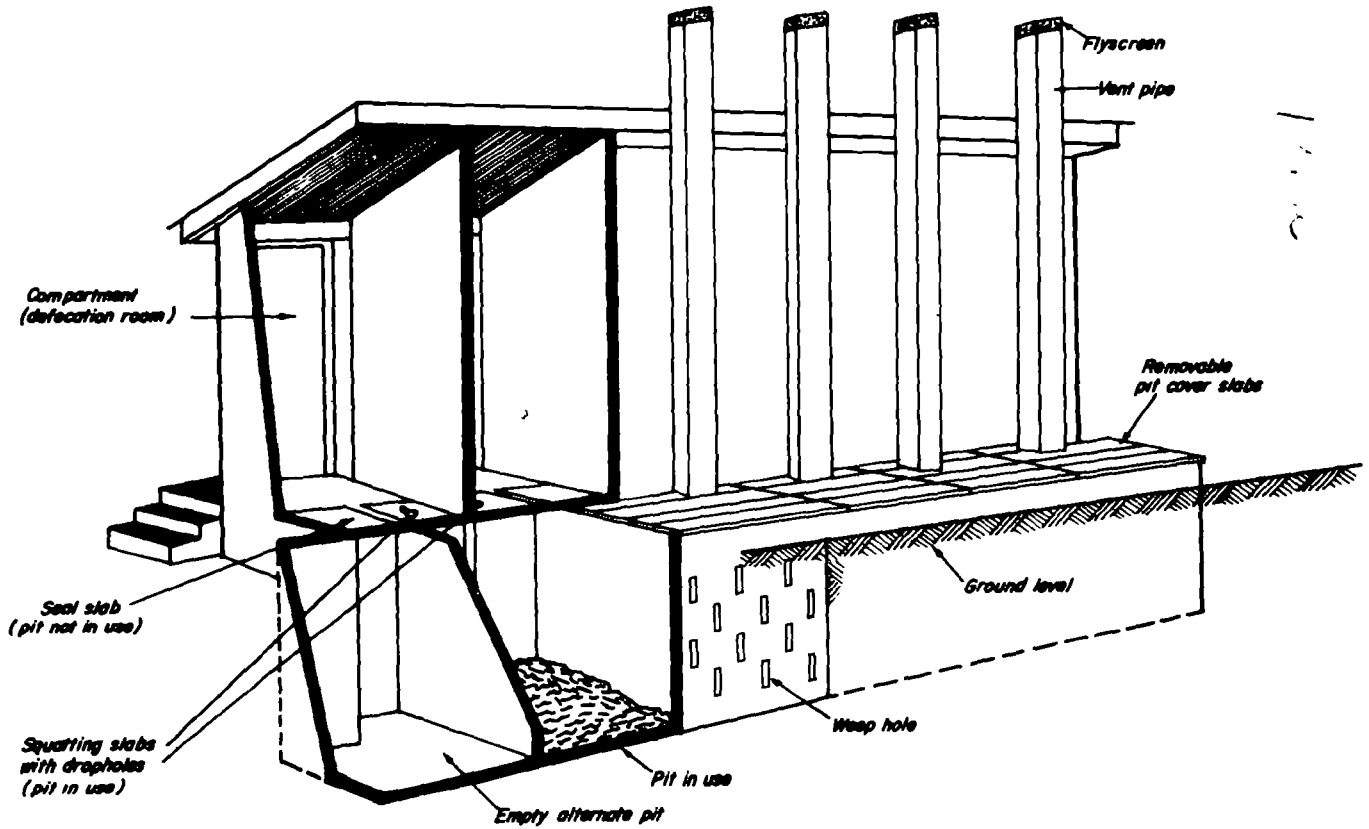

Five compartment alternating VIP latrine (rear view)

PART 1**1.1 WHAT IS A VIP LATRINE?**

Traditional pit latrines have two main disadvantages: they usually smell bad, and they attract flies and other disease carrying insects that breed in the pits. In addition, they are often poorly built and dangerous to use.

A much improved type of latrine called the ventilated improved pit latrine (or VIP latrine) has been developed, which has none of these problems. The VIP latrine has three important features that distinguish it from traditional types of pit latrines:

- it has a tall vertical vent pipe or vent stack with a flyscreen over its top
- it is designed to be safe for the user
- it has a superstructure that is slightly offset from the pit

There are two main types of VIP latrines:

1. Single pit VIP latrines, designed for use in rural areas where there is space to relocate the latrine when the pit is full.
2. Alternating pit VIP latrines, which are permanent structures with two or more pits that are used alternately.

1.2 **HOW DOES THE ALTERNATING VIP WORK?**

Each compartment of the superstructure is built over two pits, but only one pit is used at a time. When this pit is full, its drop-hole is closed and the second pit is put into service. When the second pit is full, the contents of the first pit are removed to enable it to be used again. The following sketch shows the arrangement of the compartments and pits in a five-compartment latrine.

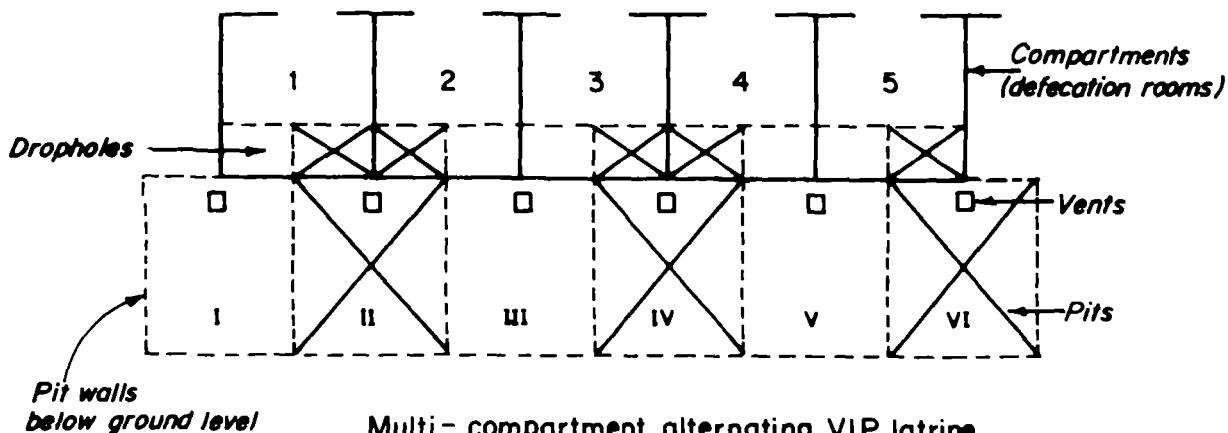

Multi-compartment alternating VIP latrine
with five compartments & six pits

(Plan view with drop-holes & pits in use marked with cross)

1.3 **WHY CHOOSE VIP LATRINES?**

In public places and institutions such as schools, colleges, and health clinics VIP latrines are popular with users because:

- they are convenient and afford privacy
- they do not smell or attract flies
- they are easy to keep clean
- they are safe

They are popular with local governments and the managers of institutions because:

- they are relatively inexpensive to build
- they require only a small quantity of water for cleaning and hand washing
- they cannot be blocked by anal cleansing materials
- they are easy to maintain
- they are permanent

1.4 **WHY DON'T VIP LATRINES SMELL?**

VIP latrines do not smell because they have a low-cost but effective system of ventilation. The wind blowing across the top of the vent pipe causes a flow of air that carries the foul-smelling gases from the pit up the vent pipe and away from the latrine.

1.5 HOW ARE FLIES CONTROLLED?

Flies are attracted by the faecal odours coming out of the vent pipe and not to the interior of the latrine compartment, which does not smell if kept clean. They cannot get in through the vent because of the flyscreen. As a result, fly infestation of the pit is kept to very low levels.

The few flies that do find their way in through the squat hole and lay their eggs in the pit are prevented from leaving by the flyscreen. Flies are attracted toward the light, and, provided that the inside of the latrine compartment is kept shaded, they will fly up the vent pipe, which will be the brightest source of light entering the pit. They cannot escape, however, because of the flyscreen, and they eventually fall back and die in the pit.

1.6 IS REMOVAL OF THE PIT CONTENTS A SMELLY AND DANGEROUS TASK?

The latrines are designed so that the pits are emptied when the contents are at least two years old. Fresh excreta is transformed in two years to harmless humus, which does not smell and presents no health risks. The humus can be removed manually or by specially designed vacuum tankers and spread safely on agricultural land or gardens or tipped with refuse.

1.7 **HOW MANY PEOPLE CAN USE A VIP?**

Most people think that a pit latrine fills very quickly when used by a large family or a group of people. In fact, excreta only accumulates in the pit at the rate of about 1.1 cu.ft. (0.03 cu.m.) per person per year, which is less than four bucket-fulls per person per year. If each pit takes at least two years to fill, the maximum number of people who can use a latrine is:

$$\frac{\text{number of pits in use} \times \text{capacity of each pit}}{1.1 \text{ cu.ft} \times 2 \text{ years}}$$

The maximum number* of people has been calculated for two-, three-, and five-compartment latrines below:

<u>Number of compartments</u>	<u>Number of Pits</u>	<u>Capacity of pits in use</u> (cu.ft.)	<u>Maximum number of people</u>
2	3	88	40
3	4	165	75
5	6	254	115

*For schools and out-patient health clinics, etc., where people return home each day, it can be assumed that only 75 percent use the latrine. For example, a day school with 100 pupils would require a latrine for $(100 \times 0.75) = 75$ people. A further reduction can be made for school holidays. For example, if the pupils attend for 42 weeks per year, the effective number of people using the latrine $= \frac{42}{52} \times 75 = 61$

1.8 WHERE SHOULD A VIP BE LOCATED?

- Do construct a latrine where it is convenient for the users. VIP latrines do not smell or attract flies so they can be built close to houses and roads.
- Do site a latrine at least 50 ft. and preferably downhill from shallow wells. (This rule applies where there is at least 6 ft. of sand or silt between the base of the pits and the groundwater table. If not, seek specialist advice.)
- Do check that the site is clear of underground cables and pipes.
- Do ensure that there is adequate access for removing material from the pits.
- Don't site the latrine where the tops of the vent pipes are sheltered. The wind blowing across the tops of the pipes draws foul air out of the pits.
- Don't build a latrine where the pits cannot be constructed above the groundwater table. If necessary the pits can be built partly above ground level and the ground around the latrine raised by filling.
- Don't build a latrine where it will be engulfed by floodwater during a storm.

Three typical arrangements for public latrines are shown on the following page. The dimensions given are the minimum recommended for one five-compartment block for men and one five-compartment block for women: the dimensions allow for each block to have two utility rooms.

2

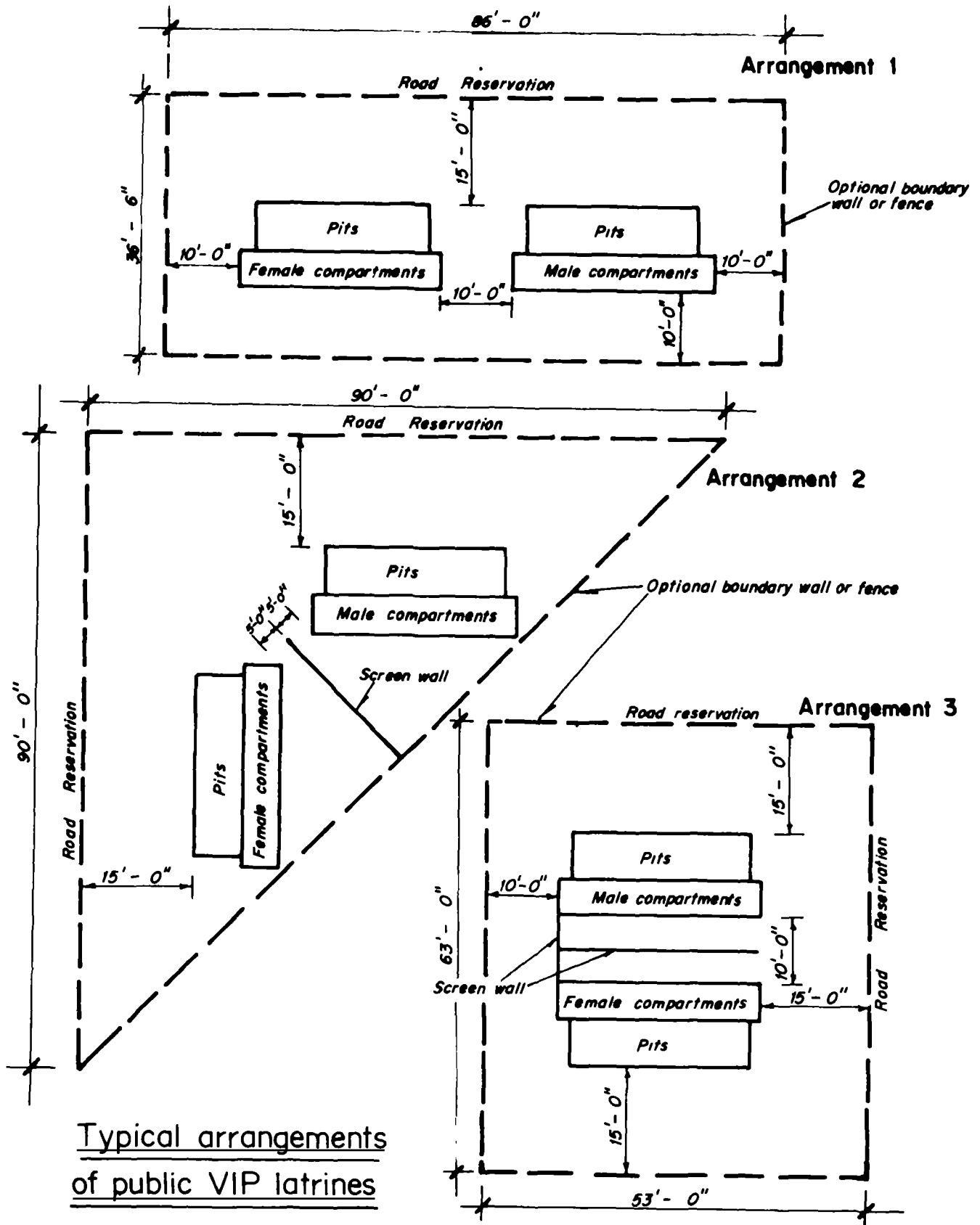

Typical arrangements
of public VIP latrines

1.9 HOW MUCH WILL CONSTRUCTION COST?

This will vary from place to place as material and labour costs and site conditions vary. Where in-house supervision and daily paid labour are used together with direct purchase of materials, a rule of thumb is Naira 1200 per compartment plus Naira 600 per utility room at 1986 prices. This does not include the cost of land. (Utility rooms are provided for attendants and/or the storage of cleaning materials.)

This rule is designed to give you an idea of cost, but wherever possible check material and labour costs in your area and use the quantities given in Part 2 and the labour required to estimate the cost of the proposed latrines.

If construction is let to a contractor, its cost will be higher and supervision will still be required.

1.10 HOW LONG WILL CONSTRUCTION TAKE?

A typical latrine construction team is made up of:

- 1 leading artisan
- 2 masons
- 1 carpenter
- 4 labourers

With this team the following schedules for constructing two-, three-, or five-compartment latrines are normal:

Schedule 1

Number of compartments	2	3	5
Set out and excavate pits, pour slabs	3 days	4 days	6 days
Construct foundations	1 day	1 day	2 days
Build pit linings and compartment footings	3 days	4 days	6 days
Build compartments	5 days	6 days	10 days
Total	12 days	15 days	24 days

1.11 WHAT ABOUT OPERATION AND MAINTENANCE?

VIP latrines are very easy to maintain and, apart from daily cleaning and occasional painting and repairs, need little attention until the pits are nearly full.

Bleach, disinfectant, or other chemicals should not be put directly into the pits because they interfere with the important biological digestion of the excreta; they also cause the pits to fill up more quickly.

The doors have bolts on the inside and outside: it is important to check regularly that the doors can be closed and the bolts operated. The flyscreen at the top of the vent should be examined periodically and replaced quickly if it has any holes in it.

When the waste in the pits in use reaches 1.5 ft. below the cover slabs, the squat slabs in the compartments should be interchanged with the seal slabs so that the full pits are closed and the empty set of pits is opened. When the second set of pits becomes full, the first set should be emptied and returned to use. When the first set becomes full again, the second set should be emptied and returned to use. This way the two pits are used alternately and indefinitely. The full pits must be rested for two years for the waste to be stabilized and free from health risks. It can then be safely removed by hand and spread on agricultural land or gardens as a soil conditioner or tipped with refuse.

Public latrines should have a fulltime attendant to keep the latrines clean and to ensure that they are not vandalised. In Lagos a charge of 10 kobo per use has been accepted by the users and is sufficient to recover the costs of the attendant, toilet paper, soap and water for hand washing, and cleaning materials. Operation and maintenance of latrines by contractors has been tried but has not proved to be very successful.

PART 2

2.1 WHAT MATERIALS ARE REQUIRED?

The following materials are required for two-, three-, and five-compartment alternating VIP latrines:

Schedule II

<u>Materials</u>	<u>Unit</u>	<u>Quantity</u>		
		<u>2 comp.</u>	<u>3 comp.</u>	<u>5 comp.</u>
9 in. x 9 in. x 18 in. blocks	no.	270	320	520
6 in. x 9 in. x 18 in. blocks	no.	140	170	260
4 in. x 9 in. x 18 in. blocks	no.	190	240	350
Cement	bags	35	50	85
Sand - sharp and smooth	cu. yd.	10	15	20
Aggregate (3/8 x 3/4 in.)	cu. yd.	2	3	5
Steel reinforcing bars (30 ft. x 3/8 in. dia.)	no.	12	17	25
<u>Formwork</u>				
3 in. x 2 in. x 12 ft. softwood for precast slabs	no.	15	20	23
6 in. x 1 in. x 12 ft. softwood for foundation and in-situ slab	no.	7	8	12
<u>Roof timbers</u>				
4 in. x 2 in. x 12 ft. softwood for rafters	no.	2	2	3
3 in. x 2 in. x 12 ft. softwood for purlins	no.	3	3	6
6 in. x 1 in. x 12 ft. planed softwood for fascia board	no.	1	1	2
Nails (assorted, including roofing)	lb. wt.	10	13	20
Aluminum or stainless steel mosquito-proof netting	sq. ft.	3	4	6

(Schedule II cont.)

<u>Materials</u>	<u>Unit</u>	<u>Quantity</u>		
		<u>2 comp.</u>	<u>3 comp.</u>	<u>5 comp.</u>
Corrugated iron, asbestos, or aluminum sheets (6 ft. x 2 ft. 3 in.)	no.	5	7	12
Hinges with screws	pairs	2	3	5
Padlock staples with screws	no.	2	3	5
Barrel bolts with screws	no.	4	6	10
Doors complete with frames	no.	2	3	5
Emulsion paint	gal.	3	4	6
Gloss paint	gal.	1	1.5	2
Solignum-type wood preservative	gal.	0.5	1	1
Turpentine	gal.	0.25	0.5	1

Allow 10 percent additional costs for water, binding wire, steel strips for securing rafters, and timber for pegs, profiles, scaffolding, etc.

(Schedule II cont.)

If a utility room is required for housing an attendant ~~or~~ storing cleaning equipment and materials, the following additional materials will be needed for each utility room:

<u>Materials</u>	<u>Unit</u>	<u>Quantity</u>
6 in. x 9 in. x 18 in. blocks	no.	24
4 in. x 9 in. x 18 in. blocks	no.	61
Cement	bags	7
Sand-sharp and smooth	cu. yd.	1
Roof timbers		
4 in. x 2 in. x 12 ft. softwood for rafters	no.	0.5
3 in. x 2 in. x 12 ft. softwood for purlins	no.	1
6 in. x 1 in. x 12. ft planed softwood for fascia board	no.	1
Nails (assorted, including roofing nails)	lb. wt.	3
Corregated roofing sheets	no.	3
Hinges with screws	pair	1
Padlock staple with screws	no.	1
Door complete with frame	no.	1
Emulsion paint	gal.	1
Gloss paint	gal.	0.5

2.2 HOW IS THE LATRINE CONSTRUCTED?

A. The building team

Successful results have been obtained using labour employed on a daily basis, supervised by a higher technical officer or leading artisan. It is best to agree on a price for the excavation with the labourers so that there is an incentive to complete this stage as quickly as possible.

The performance of contractors in latrine construction has been poor. If it is necessary to use contractors, ensure that:

- the contract includes a brief but adequate specification of materials and workmanship
- the contractor does not underestimate the job
- the work is supervised by an engineer or technician, who will understand the drawings.

B. Getting started

Setting out should be as simple as possible. Begin by using ordinary wooden pegs set back from the sides of the excavation and then string lines to demarcate the excavation. Excavated material should be thrown as far as possible from the pit to create a good working space around the pit.

When the excavation is complete, the setting out can be transferred to the base of the excavation. Six-inch deep trenches are then cut in the base of the excavation for the concrete foundations, and pegs are set in the trenches using a spirit or water level to ensure that the tops of the foundations are level.

The foundations are constructed using concrete with 1 : 3 : 6 mix (one part by volume of cement : three parts sand : six parts aggregate) and just enough water to make the concrete workable. The aggregate (stones, gravel) should be clean and free from stones larger than 1.5 in. diameter. Do not throw the concrete from ground level into the pit. Labourers should be in the pit to receive and pour the concrete, which should be well rammed into position.

C. Precasting the slabs

The slabs should be cast while the excavation is in progress, or earlier, so that they have at least seven days to gain strength before they are built into the latrine structure. The area used for casting should be level and preferably screeded with 2 to 3 in. of concrete. Never cast slabs on bare earth or concrete and always lay the formwork on plastic sheeting or used cement bags.

The formwork should be carefully fabricated so that it can be easily dismantled to release the slabs and be reused.

Good precast concrete slabs require clean aggregates and a 1 : 2 : 4 mix. The following procedure should be used for casting:

- (a) Clear the casting area of all debris.
- (b) Spread plastic or paper sheeting on the area.
- (c) Place the formwork on the sheeted area and oil or grease the inside faces of the formwork.
- (d) Fix the reinforcing steel in position ensuring that there is at least 1/2 in. between the base of the slab and the steel.
- (e) Mix the concrete to the correct proportions, place in the formwork, and compact and level with a wooden float. Ensure that the steel reinforcement is not dislodged from its correct position.
- (f) When the concrete begins to set, use a steel float to achieve a smooth finish.
- (g) For squatting, sitting, and vent slabs make sure that the formwork around the holes is carefully finished before the concrete sets.
- (h) Leave the concrete covered and preferably kept damp for twenty-four hours before carefully removing the formwork.
- (i) Keep the slabs covered and damp for six more days before installing them.

D. The pit lining

Two sizes of blocks are used for the pit lining, 9 in. and 6 in. thick, and their arrangement should conform to the drawings at the back of this manual. All partition walls in the pit are solidly built with all joints sealed. In the outside walls some of the joints in the second, third, fourth, and fifth courses should be left open to allow for seepage of liquid waste into the surrounding soil.

The top of the pit lining should have a fall of about 2 in. from the front to the rear wall of the pits. This slope should be formed with a 1 : 4 cement sand mortar. This allows for rainwater to run off the pit cover slabs.

Before the last two courses of the pit lining are complete, the foundation to the latrine compartments is excavated and the concrete foundation placed to the top level of the fifth course of the pit lining. This facilitates a good joint between the top two courses of the pit lining and the first two courses of the footings to the latrine compartments.

E. Installing the vent slabs

The vent slabs are fixed using 1 : 4 cement sand mortar, taking care that the slope on the top of the pit lining is maintained. The vent slabs become permanent features of the structure because they support the rear wall of the latrine compartments.

F. The floor slab

After the vent slabs are installed, the footings to the latrine compartments are completed by laying one further course and back-filling with selected excavated material (that is, material which is readily compacted) to the underside of the floor slab. Formwork for the 3 in. thick floor slab is then fixed and the slab poured, using 1 : 3 : 6 mix concrete.

G. The latrine compartments

The compartments should be set out carefully on the floor slab to ensure that they are uniform and the dimensions adequate to accommodate the squatting and sealing slabs. The 4 in. or 4.5 in. blockwork should be laid flush with the outside edge of the floor slab to form the exterior walls and the 9 in. blocks forming the vent pipes should be keyed into the rear wall. These 9 in. blocks should be laid with the opening in each block tapering downwards and the internal joints carefully pointed and clear of loose mortar.

Door frames should be made up from 2 in. x 4 in. planed softwood and primed before they are fixed. Where possible the door frames should be positioned first and the blockwork built up around them.

The compartments are built with eight courses of blockwork in the front wall and nine in the rear. The roof falls to the front and this prevents rainwater being discharged onto the pit covers.

The doors are made from 1 in. thick planed softwood boards, preferably tongued and grooved or rebated, and battened with 4 in. x 1 in. softwood. The battens should take account of which way the door is to be hung: an incorrectly battened door will distort and sag. Hinges should be fixed using screws and not nails. Gaps of 6 in. above and 4 in. below the doors are provided for ventilation.

H. The roof

The materials normally used for roof construction are:

- 4 in. x 3 in. rafters
- 3 in. x 2 in. purlins
- 6 in. x 1 in. fascia boards
- corrugated iron, asbestos, or aluminum sheets

The roof construction should be as simple as possible. The rafters are partially built into the front and back walls and strapped to each cross wall with steel strips nailed to the wall. The purlins are nailed to the rafters and the roof sheets to the rafters ensuring that there is at least a 6 in. overlap between sheets. The fascia board should be fixed tight against the side and rear walls but 3 in. clear of the front wall to keep rainwater draining from the roof off the front wall.

I. Fixing the squatting and seal slabs

Inside the compartments the concrete floor screed is laid first, using 4 in. thick blocks to form a rebate to receive the squatting and seal slabs. The gaps between the slabs and the walls, between the two slabs and a gap of 2 in. width at the front of the slabs, should be packed with sand and finished off with 1/2 in. depth of 1 : 4 cement sand mortar. This is to facilitate the interchange of the squatting and seal slabs when a pit is full.

Some institutions may prefer a seat to a squatting slab. This can be arranged by replacing the squatting and seal slabs by a single sitting slab resting on a 15.5 in. high lockwork upstand. The sitting slab has two holes in it: one is closed with a wooden cover and the other is equipped with a wooden seat.

The pit cover slabs are laid on a bed of 1 : 10 cement sand mortar and the joints between them carefully sealed with the same weak mortar to facilitate removal of the slabs for emptying the pits. It is important that these joints are sealed, otherwise flies will use the joints to enter and leave the pits.

J. Ventilated pipes and screens

Vent pipes can be made from plastic or asbestos pipe or from 9 in. x 9 in. x 18 in. blocks. The blocks are preferred because they are cheaper and less likely to be damaged after installation. If plastic

or asbestos pipes are used, the vent pipe at each end is 4 in. diameter while the pipes in between are 6 in. diameter. The pipes should be fixed with concrete at the base and strapped to either the wall or fascia at the top.

Aluminum or stainless steel mesh is recommended for the flyscreens since plastic screens deteriorate rapidly in strong sunlight and galvanized mesh quickly loses its protective zinc coating and corrodes. The holes in the mesh should not be larger than 1.5 mm. If the holes are too small ventilation will be obstructed.

On blockwork vent pipes the flyscreen is fixed in position using a hardwood frame that simply fits over the top of the vent pipe. This arrangement keeps the area of mesh to a minimum and facilitates replacement of the mesh. On PVC or asbestos vent pipes the mesh is held in position by a wire tied around the pipe.

K. Finishes

A well-finished latrine advertises the skill of the builders and may encourage people to maintain it.

The internal and external walls of the latrine compartments and the exposed tops of the pit walls and footings to the compartments are normally rendered with a 1/2 in. thick coat of 1 : 4 cement sand plaster, although at least one local government has tiled the internal walls of its latrines. The rendering is painted inside and

outside with two coats of emulsion paint. The roof timbers are simply treated with solignum wood preservative while the fascia board, doors, and frames are primed and painted with two coats of gloss paint. Colour schemes vary, but external and internal walls are typically painted grey, the fascia board and the exposed tops of the pit walls black, and the doors grey or cream. In one case light pink paint was used to good effect on the external walls.

1.2/04/87

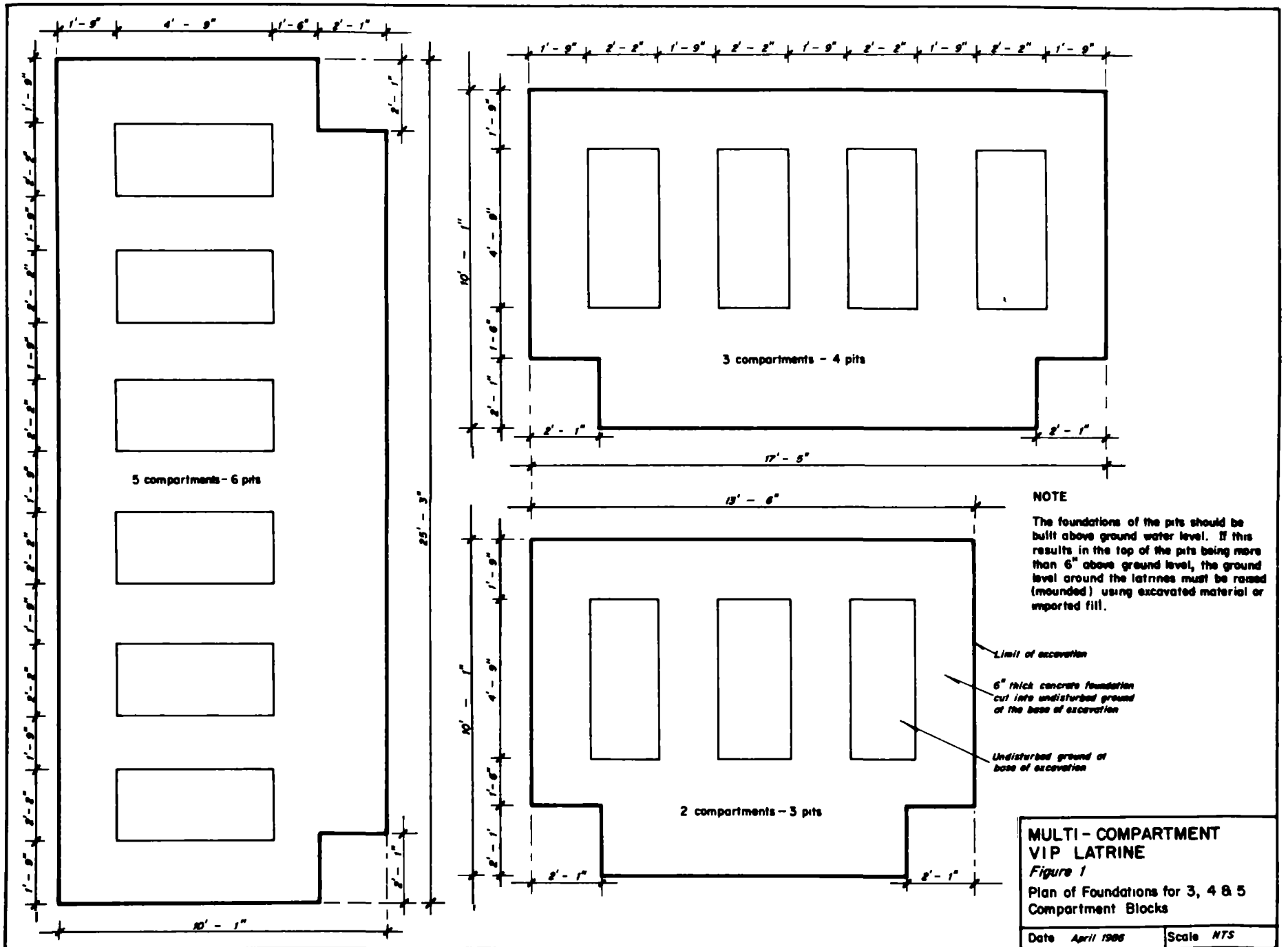

**MULTI-COMPARTMENT
 VIP LATRINE**
Figure 1
 Plan of Foundations for 3, 4 & 5
 Compartment Blocks

Date	April 1966	Scale	NTS
------	------------	-------	-----

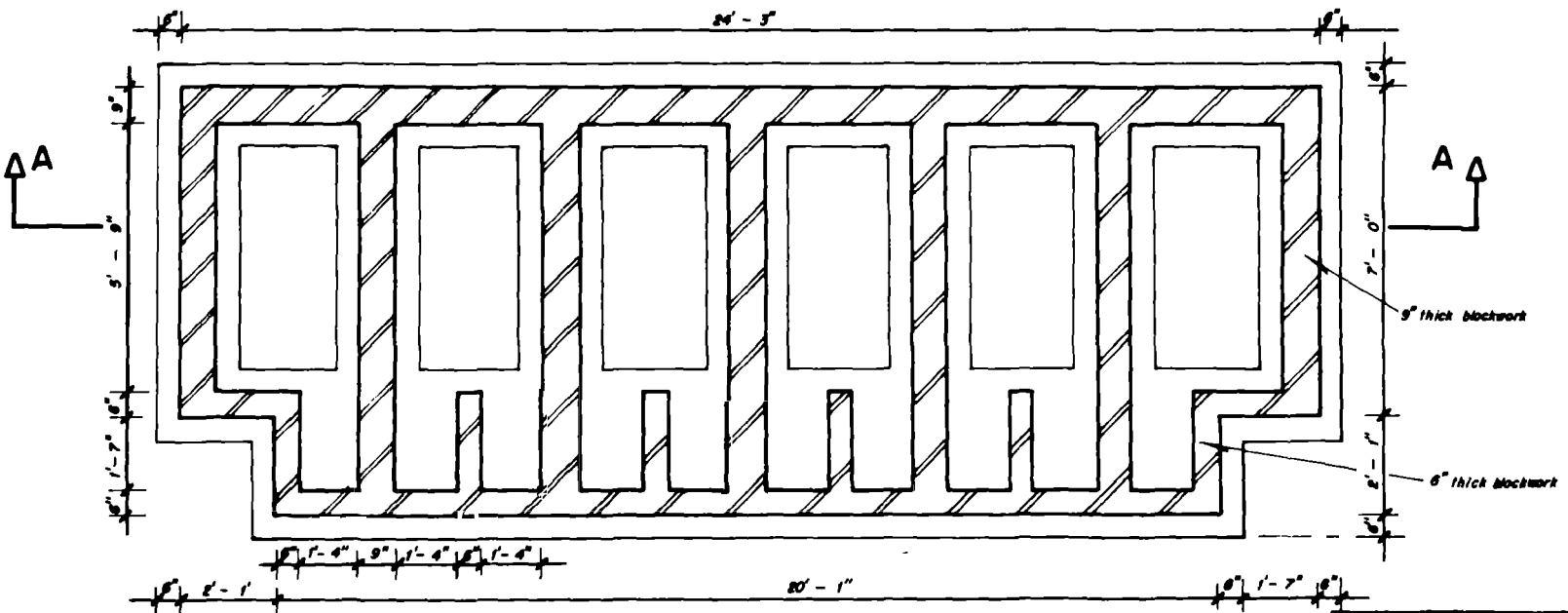
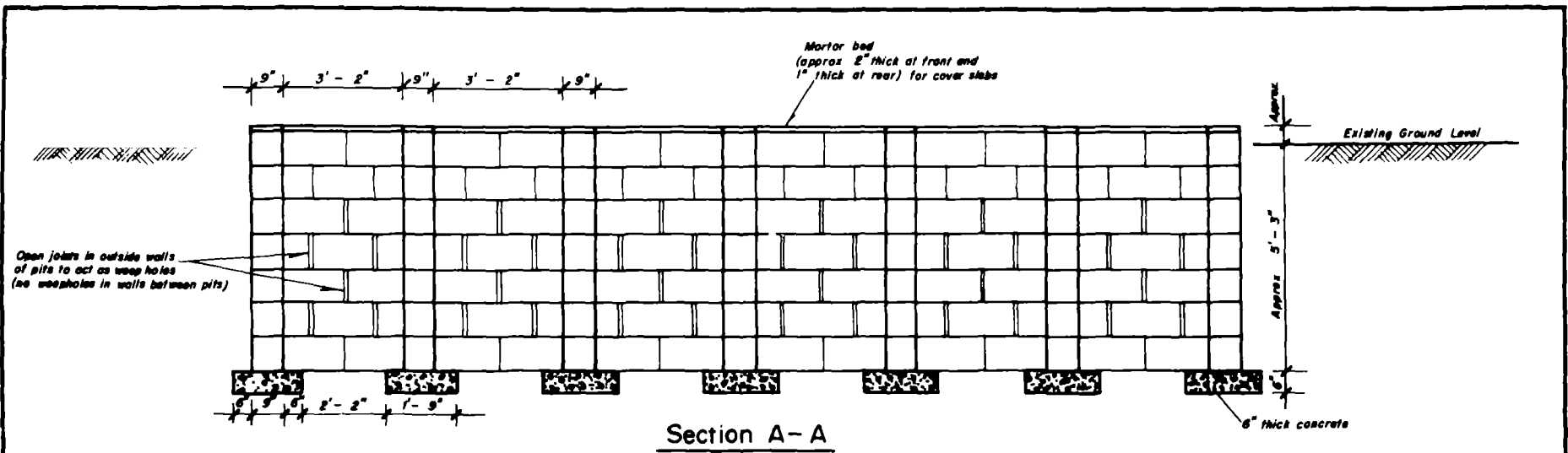

Plan of Blockwork for Pit Lining

**MULTI - COMPARTMENT
VIP LATRINE**
 Figure 2
 Blockwork for Pit Lining
 (5 Compartment Block)

Date: April 1966 Scale: N.T.S.

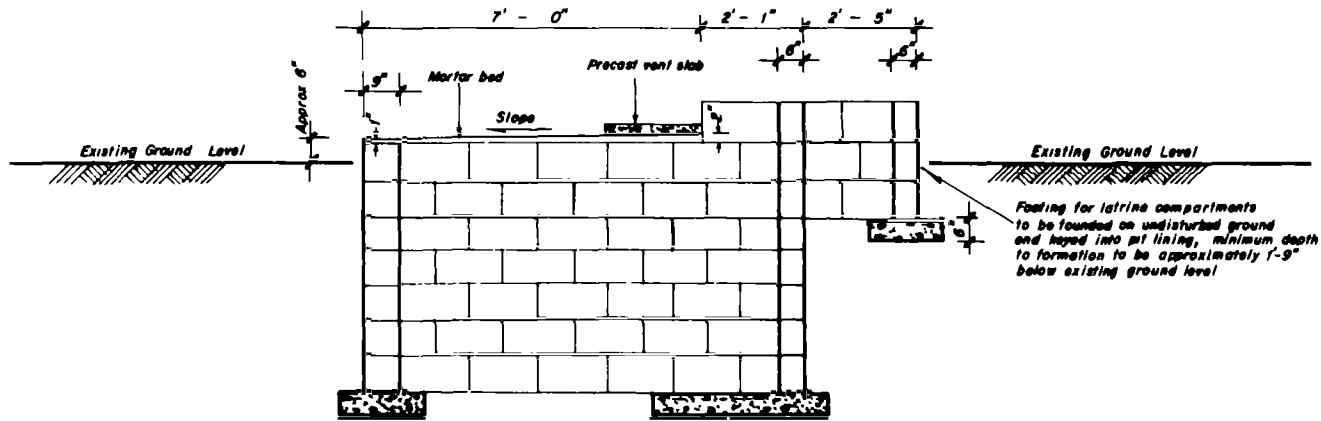

Section B - B Showing Pit Lining & Footings for Latrine Compartments

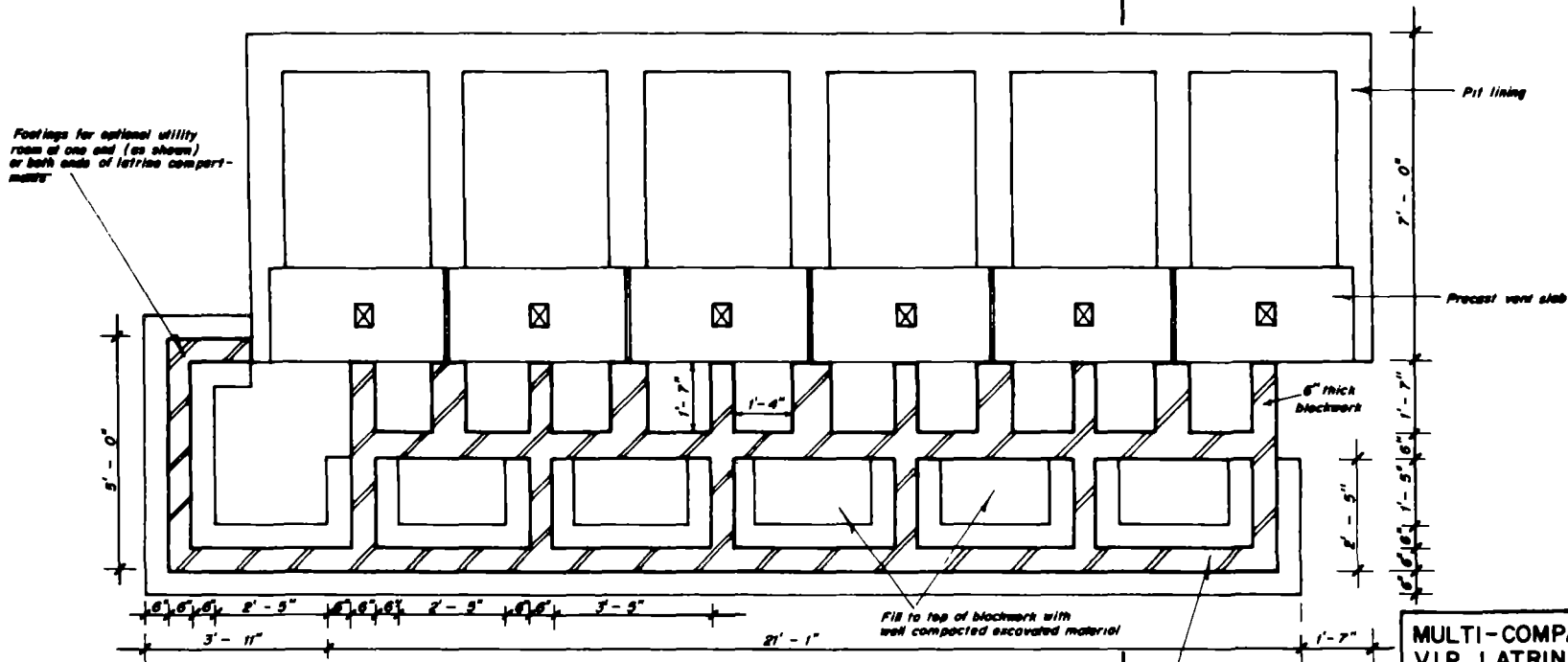

Plan Showing Footings For Latrine Compartments

MULTI-COMPARTMENT VIP LATRINE
 Figure 3
 Footings for Latrine Compartments (5 Compartment Block)

Date April 1966 Scale N T S

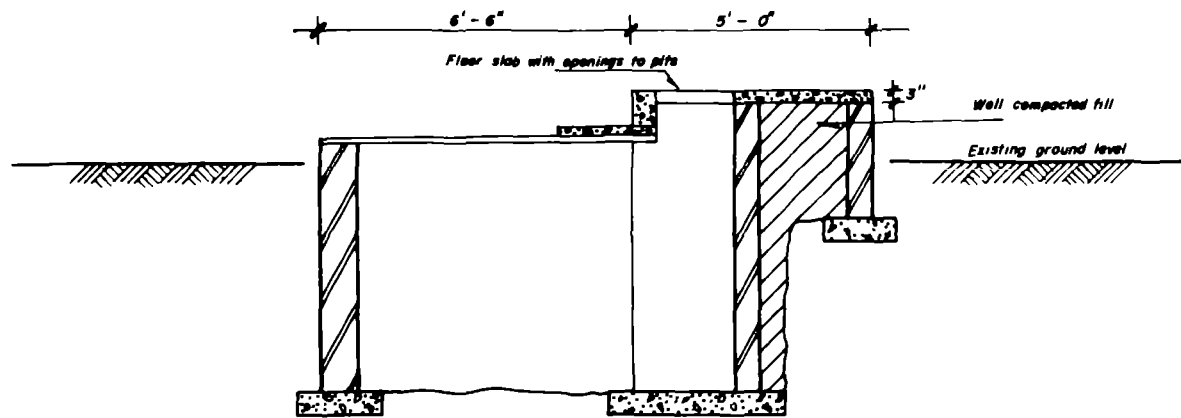

Section C - C

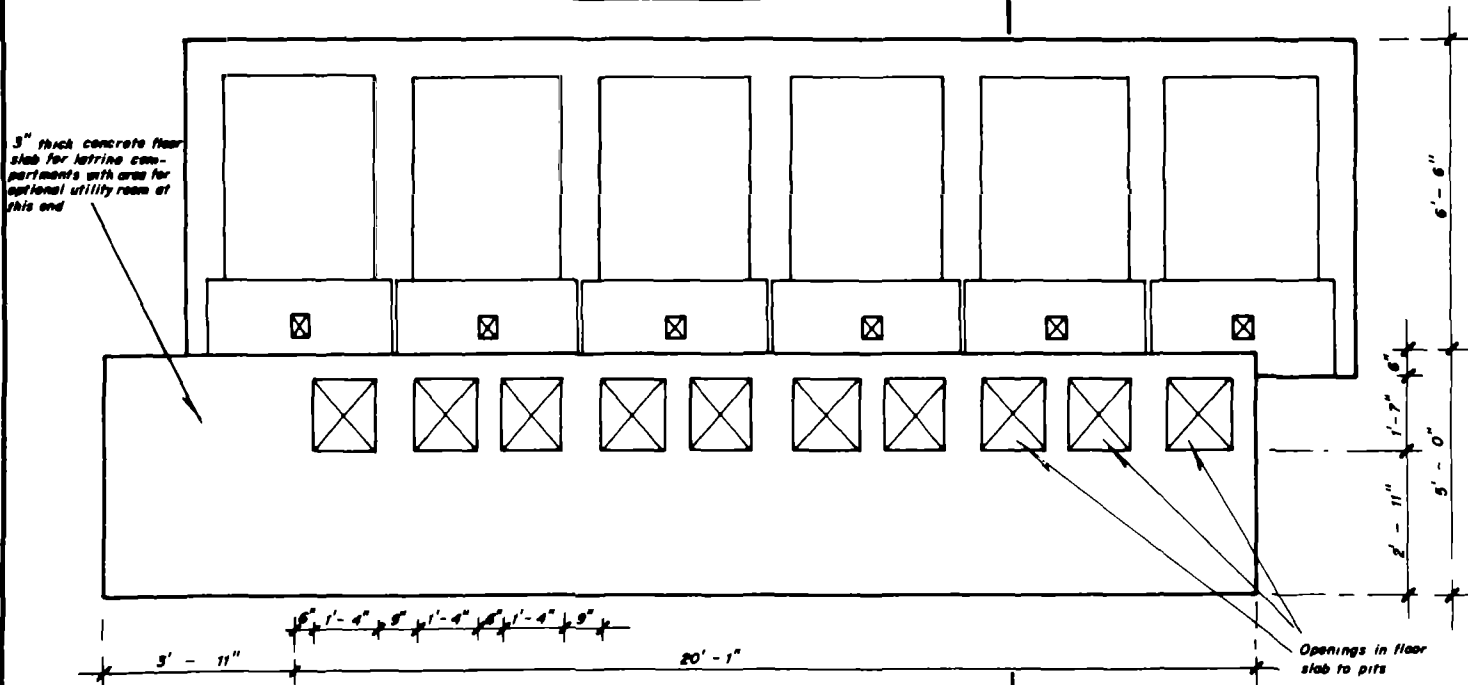

Plan Showing Floor Slab

**MULTI-COMPARTMENT
VIP LATRINE**
Figure 4
Floor Slab for Latrine Compartments
(5 Compartment Block)

Date April 1986	Scale NTS
-----------------	-----------

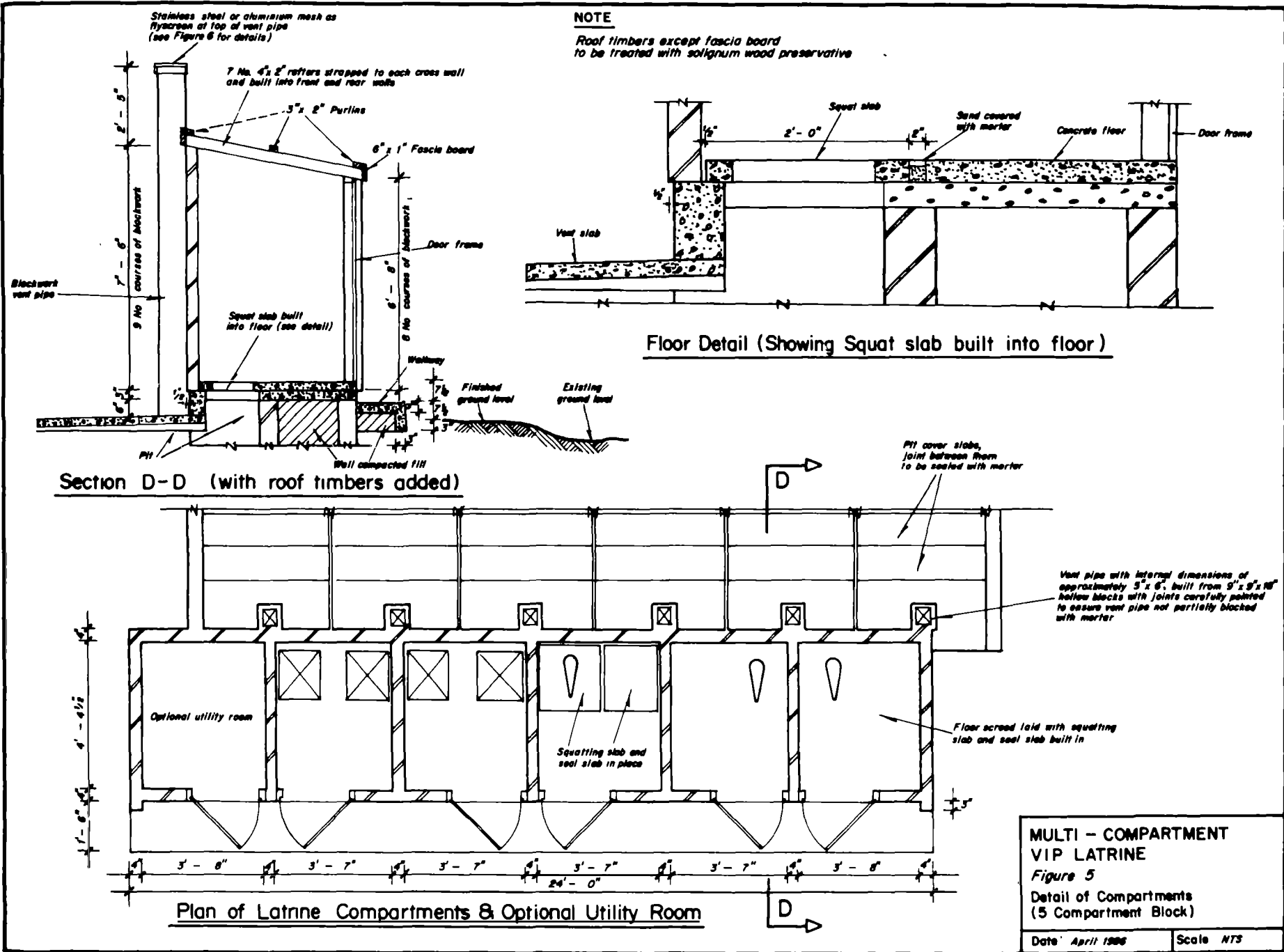

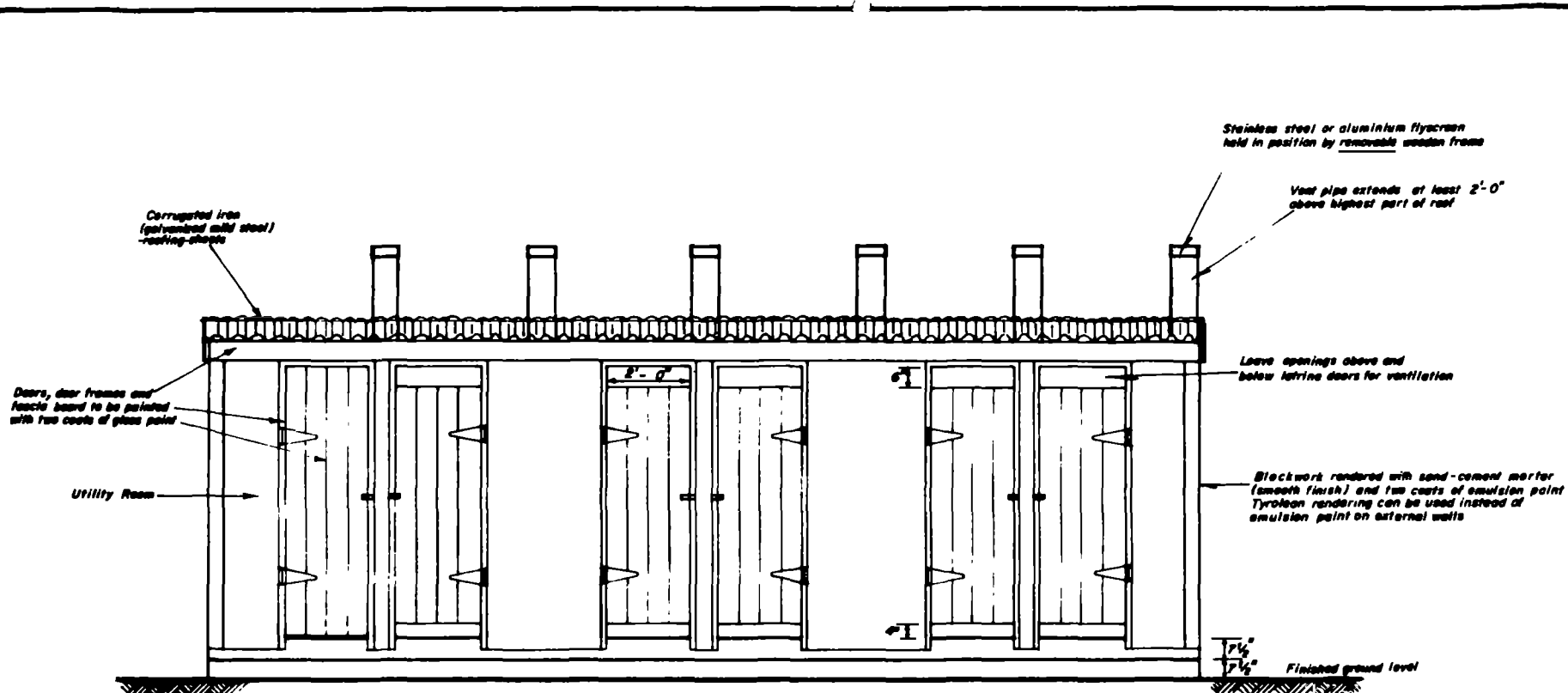

Front Elevation

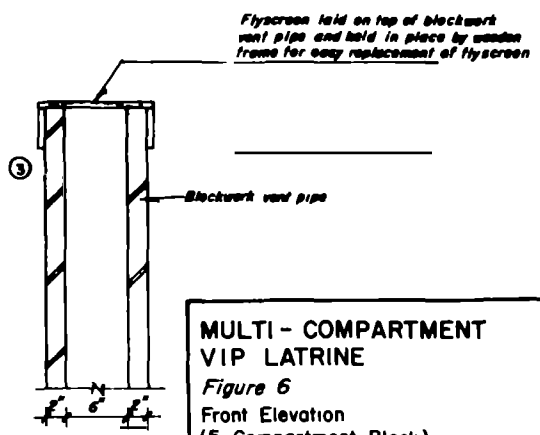
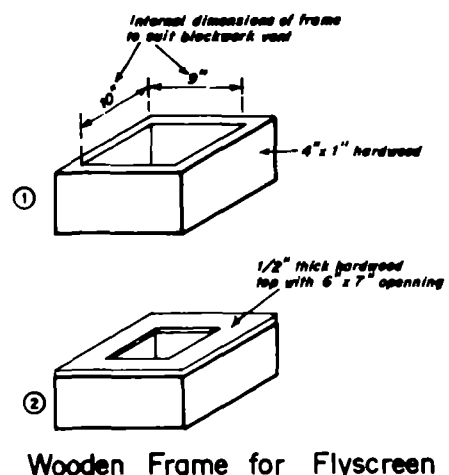
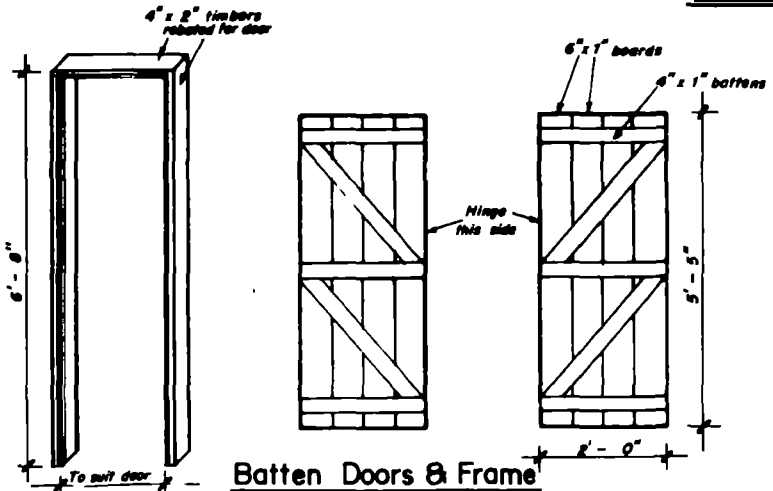

**MULTI - COMPARTMENT
VIP LATRINE**
Figure 6
Front Elevation
(5 Compartment Block)

VENT SLAB

3" thick

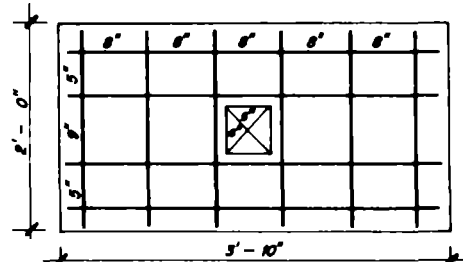

COVER SLAB

3" thick

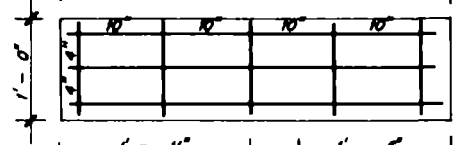

SQUAT SLAB

3" thick

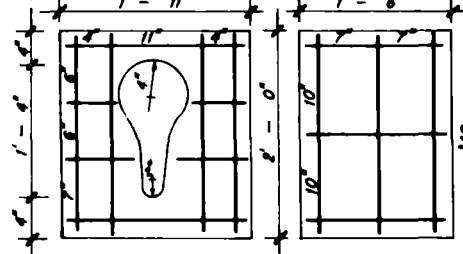

SEAL SLAB

3" thick

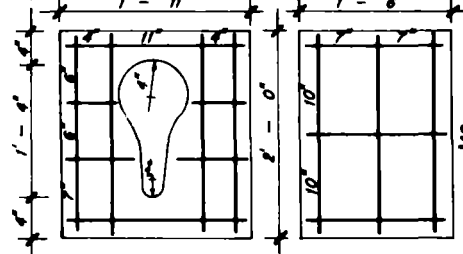

SLAB TYPE	No. OF SLABS	CUT LENGTH AND DIAMETER OF BARS	No. OF BARS IN SLAB	TOTAL No. OF BARS REQUIRED	No. OF 30'-0" BARS	REMARKS
VENT	6	3'-6" x 3/8" #	4	24	3	Quantities shown are for 1 No five compartment VIP latrine. Total number of 30'-0" x 3/8" # bars required is 25. Slabs required for 3 compartment latrine are: 4 No vent, 20 No cover, 3 No squat and 3 No seal, total number of 30'-0" x 3/8" # bars required is 17. Slabs required for 2 compartment latrine are: 3 No vent, 15 No cover, 2 No squat and 2 No seal, total number of 30'-0" x 3/8" # bars required is 12.
		1'-10" x 3/8" #	6	36	23	
COVER	30	3'-6" x 3/8" #	3	90	113	
		10" x 3/8" #	5	150	42	
SQUAT	5	1'-10" x 3/8" #	4	20	13	
		1'-9" x 3/8" #	2	10	6	
		5" x 3/8" #	2	10	2	
SEAL	5	1'-10" x 3/8" #	3	15	1	
		1'-4" x 3/8" #	3	15	7	

NOTES

(1) A raised sitting slab with wooden seat and cover can be used instead of the squat and seal slabs.

(2) The vent, cover, squatting and seal slabs are 3" thick with minimum cover to reinforcement of 1". The sitting slab is 1 1/2" thick with minimum cover of 1/2".

(3) Slabs must be precast at least 7 days before installation in the latrine structure.

Line of 9" blocks built up to 15 1/2" above latrine floor as support for slab

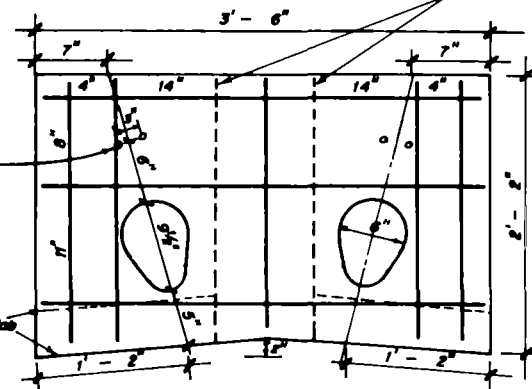

Form 1/2" # holes for bolts to hold down wooden seat (see below)

Line of 4" blocks built up to 15 1/2" above latrine floor as support for slab

SITTING SLAB

(Alternative to squat and seal slabs)

1 1/2" Thick

SLAB TYPE	No. OF SLABS	CUT LENGTH AND DIAMETER OF BARS	No. OF BARS IN SLAB	No. OF 30'-0" BARS
SITTING	1	3'-4" x 3/8" #	3	4
		1'-10" x 3/8" #	5	4

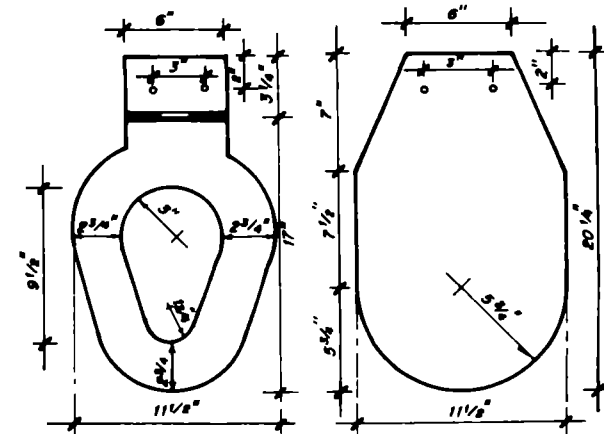

WOODEN SEAT

For pit in use

WOODEN COVER

For sealed pit

MULTI - COMPARTMENT VIP LATRINE

Figure 7

Reinforced Concrete Slabs

Date May 1965

Scale NTS

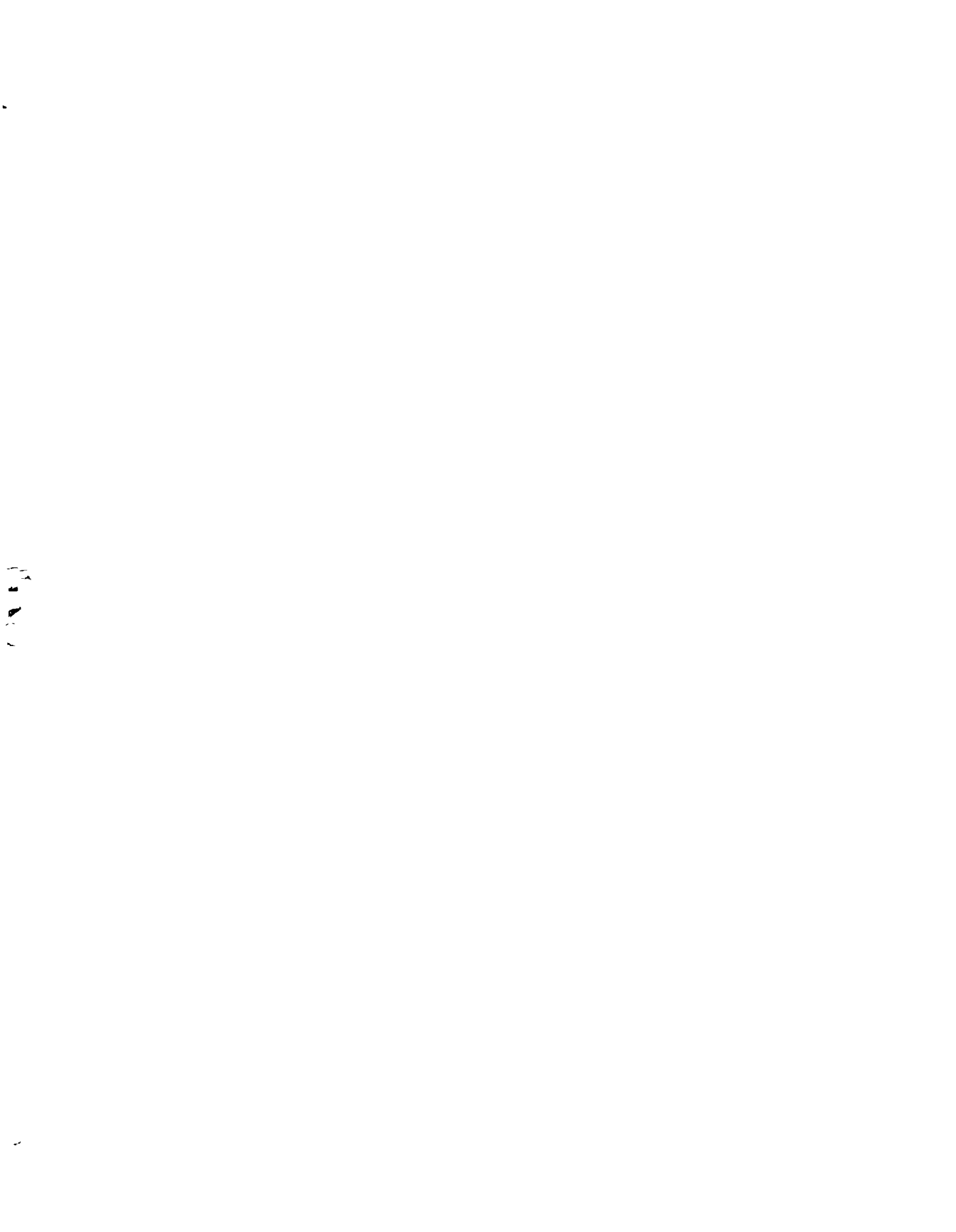

12

13