

8 2 8
P G 8 6



WORLD HEALTH ORGANIZATION
FOR HEALTH PROJECT

Operated by
CDM and Associates

Sponsored by the U S Agency
for International Development

1611 N. Kent Street, Room 1002
Arlington, Virginia 22209 USA

Telephone: (703) 243-8200
Telex No. WUI 64552
Cable Address WASHAID

The WASH Project is managed
by Camp Dresser & McKee
International Inc. Principal
cooperating institutions and
subcontractors are: Associates
in Rural Development, Inc.;
International Science and
Technology Institute, Inc.;
Research Triangle Institute;
Training Resources Group;
University of North Carolina
at Chapel Hill.

LIBRARY
NATIONAL REFERENCE CENTRE
FOR WATER SUPPLY AND
SANITATION (WASH)
**EVALUATION OF THE WATER SUPPLY
AND SANITATION COMPONENT
OF THE ADB-SPONSORED
RURAL HEALTH SERVICES PROJECT
IN PAPUA NEW GUINEA**

WASH FIELD REPORT NO. 182

JUNE 1986

**Prepared for
the USAID Mission to Fiji and
the Government of Papua New Guinea
Department of Health
WASH Activity No. 211**

828-2305

WASH FIELD REPORT NO. 182

**EVALUATION OF THE WATER SUPPLY AND SANITATION COMPONENT
OF THE ADB-SPONSORED RURAL HEALTH SERVICES PROJECT
IN PAPUA NEW GUINEA**

Prepared for the USAID Mission to Fiji and the
Government of Papua New Guinea Department of Health
under WASH Activity No. 211

APPLIED TECHNOLOGY CENTER
FOR RURAL WATER SUPPLY
AND SANITATION
The League
of Nations
6588
328 PG 86
by JSN 2305

Joseph Haratani

James S. Baker
and
James K. Jordan

June 1986

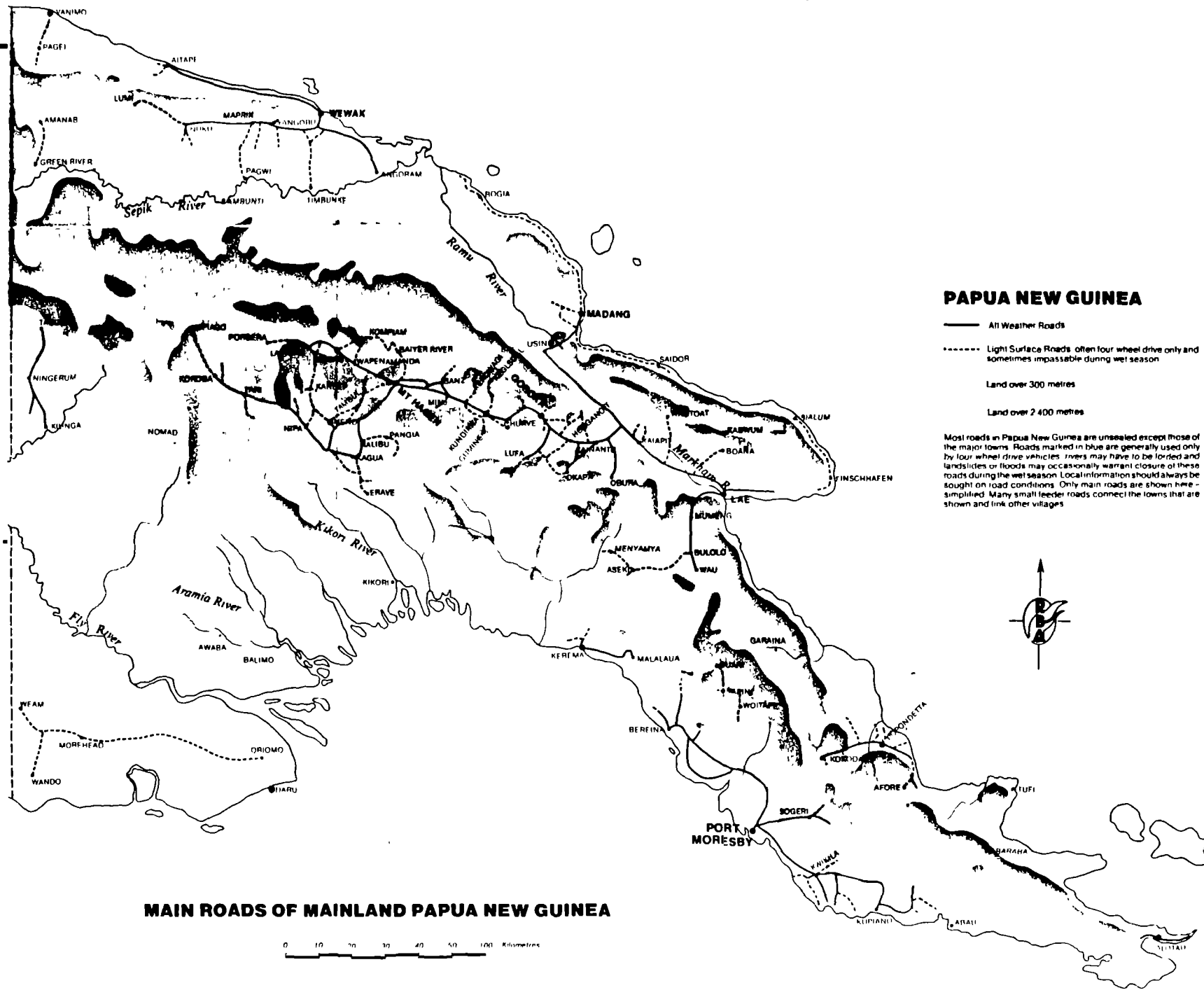

Table of Contents

| Chapter | Page |
|--|------|
| ACRONYMS..... | iii |
| ACKNOWLEDGEMENTS..... | v |
| EXECUTIVE SUMMARY..... | vii |
| 1. INTRODUCTION..... | 1 |
| 1.1 Description of Papua New Guinea..... | 1 |
| 1.2 Project Background..... | 1 |
| 1.2.1 ADB-1..... | 1 |
| 1.2.2 ADB-2..... | 2 |
| 1.3 Evaluation Request and Purpose..... | 2 |
| 1.4 Scope of Work..... | 3 |
| 1.5 Consultants' Activities..... | 4 |
| 2. OVERVIEW OF SECTOR..... | 5 |
| 2.1 Government Institutions in Papua New Guinea..... | 5 |
| 2.2 External Assistance..... | 5 |
| 3. FINDINGS AND CONCLUSIONS..... | 7 |
| 3.1 General..... | 7 |
| 3.2 Project Resources..... | 8 |
| 3.2.1 Human and Material Resources..... | 8 |
| 3.2.2 Financial Resources..... | 10 |
| 3.3 Project Management..... | 10 |
| 3.3.1 Administration..... | 10 |
| 3.3.2 Effects of Decentralization..... | 11 |
| 3.3.3 Organizational Status of the Water Supply and Sanitation Component..... | 12 |
| 3.3.4 Project Monitoring..... | 12 |
| 3.3.5 Logistics..... | 12 |
| 3.4 Project Activities..... | 13 |
| 3.4.1 General..... | 13 |
| 3.4.2 Baseline Data Collection..... | 13 |
| 3.4.3 Program Planning..... | 14 |
| 3.4.4 Community Participation..... | 14 |
| 3.4.5 The Role of Women..... | 15 |
| 3.4.6 Village Site Selection..... | 16 |
| 3.4.7 System Design and Construction..... | 17 |
| 3.4.8 Turnover of Water Systems..... | 20 |
| 3.4.9 Operation and Maintenance..... | 21 |
| 3.4.10 Vandalism..... | 24 |
| 3.5 Project Financing..... | 24 |
| 3.5.1 General..... | 24 |
| 3.5.2 Reimbursable Costs..... | 25 |
| 3.5.3 Financial Performance to Date..... | 26 |
| 3.5.4 Financial Projections..... | 26 |

| Chapter | Page |
|---|-------------|
| 3.5.5 Effectiveness in Fund Utilization..... | 29 |
| 3.5.6 Opportunities for Improving Fund Utilization..... | 30 |
| 3.6 Staff Training..... | 31 |
| 4. RECOMMENDATIONS..... | 55 |
| 4.1 Project Resources..... | 55 |
| 4.2 Project Management..... | 55 |
| 4.3 Project Activities..... | 57 |
| 4.4 Project Financing..... | 59 |
| 4.5 Staff Training..... | 60 |
| | |
| LOGICAL FRAMEWORK..... | 63 |
| | |
| REFERENCES..... | 65 |
| | |
| APPENDICES | |
| A. Persons Contacted..... | 67 |
| B. Summary of Field Visit Data..... | 73 |
| C. National Policy for Rural Water Supply and Sanitation..... | 81 |
| D. National Water Supply and Sewerage Board, Policies for Implementa- tion..... | 87 |
| E. National Water Supply and Sewerage Board, Areas of Responsibilities and Delegation..... | 93 |
| F. Project Consultants..... | 99 |
| G. Provincial Organization Charts..... | 103 |
| H. List of Village Water Supply Surveys..... | 111 |
| I. Sample Village Water Supply Survey..... | 115 |
| J. Village Application Form..... | 119 |
| K. Project Proposal Fact Sheet..... | 123 |
| L. Project Completion Certificate..... | 127 |
| M. Financial Systems of the Government of Papua New Guinea..... | 131 |
| N. Department of Works, Oliguti Training Syllabus..... | 141 |
| | |
| TABLES | |
| 1. ADB-1 Problems and ADB-2 Provisions..... | 7 |
| 2. Provincial Water Supply and Sanitation Staff in 1982..... | 9 |
| 3. Additional Resources for the Water Supply and Sanitation Component... | 9 |
| 4. Summary Ratings of Water Systems Visited..... | 18 |
| 5. Financing Parameters as Project Formulation..... | 27 |
| 6. Program Expenditures and Loan Disbursements..... | 28 |
| 7. Projected Program Expenditures and Reimbursements Under Alternate Funding Assistance Terms..... | 29 |
| 8. Water and Sanitation Workshops Held and Planned..... | 32 |

ACRONYMS

| | |
|-------|--|
| ADB | Asian Development Bank |
| ADB-1 | First Primary Health Services Project |
| ADB-2 | Second Primary Health Services Project |
| A/P | Aid Post |
| APO | Aid Post Orderly |
| A/S | Assistant Secretary |
| ATDI | Appropriate Technology Development Institute |
| BMS | Bureau of Management Services |
| BPC | Budget Priorities Committee |
| CSF | Camp, Scott, Furphy Pty. Ltd. |
| CAHS | College of Allied Health Services |
| C/S | Community School |
| DHI | District Health Inspector |
| DNPD | Department of National Planning and Development |
| DOF | Department of Finance |
| DOH | Department of Health |
| DOW | Department of Works |
| GOPNG | Government of Papua New Guinea |
| H/C | Health Center |
| HSC | Health Sub-center |
| HI | Health Inspector |
| HIA | Health Inspector Assistant |
| IHAP | International Human Assistance Program |
| ILPOC | Integrated Local Purchase Order and Claim (Form) |
| IMR | Institute of Medical Research |
| LGE | Local Government Engineers Section of DOW |

| | |
|--------|---|
| MEP | Minimum Evaluation Procedure (WHO) |
| NGO | Non-governmental organization |
| NPED | National Public Expenditure Plan |
| NTSU | National Training Support Unit |
| NWS&SB | National Water Supply and Sewerage Board |
| O&M | Operation and Maintenance |
| OIC | Officer in Charge (of Water and Sanitation Component) |
| PDH | Provincial Division of Health |
| PHEO | Provincial Health Extension Officer |
| PHI | Provincial Health Inspector |
| PHO | Provincial Health Officer |
| PIU | Project Implementation Unit of the DOH for ADB-1 |
| PNG | Papua New Guinea |
| PSC | Public Service Commission |
| PTB | Public Transport Bureau |
| PVO | Private Voluntary Organization |
| SC | Health Sub-center |
| SPATF | South Pacific Appropriate Technology Foundation |
| UNDP | United Nations Development Program |
| USAID | United States Agency for International Development |
| WASH | Water and Sanitation for Health |
| WHO | World Health Organization |
| WS | Water supply |
| WS&S | Water Supply and Sanitation |

Currency Equivalent

.95 Kina = \$1.00 U.S. in March 1986
100 toea = 1 Kina

ACKNOWLEDGMENTS

The WASH team wishes to thank each of the persons contacted for his cooperation and information provided. The list of names is too long to be repeated here and is included in this report as Appendix A.

The team would be negligent not to acknowledge those persons who made a special effort to adjust their schedules in order to accommodate our needs. Our special thanks go to the Secretary of Health, Dr. Quentin Reilly, and to each of the members of the ADB-1 Project Implementation Unit (PIU), and to Dr. Patrick C. Lowry, USAID/Suva, for arranging this evaluation.

Also deserving special recognition and thanks, are the provincial officers in charge who traveled with and guided the team on field trips to visit water supply and sanitation installations. They are Benjamin Marin (Madang), Emo Alfred Wapiri (Western Highlands), Stephen Amos (East Sepik), Balthasa Kipit (West Sepik), Stephen Ani and Egi Valahu (Central), and Emil Trowalle (Gulf).

The individual who was our key contact person and who did a splendid job of scheduling meetings and travel deserves special recognition. Thank you very much, Jane Thomason, ADB Project Coordinator.

We also wish to express our appreciation to Mr. Lindsay Rockett of Camp, Scott, Furphy Pty/Ltd. of Boroko for providing office support and professional services during our assignment, and to the ADB, WHO and UNICEF staff for briefing the team and providing background information.

Finally, we cannot forget our hosts in the many villages we visited. A special thank you to the gracious people of Papua New Guinea. Tenkyu Tru!

EXECUTIVE SUMMARY

In November 1982, the Government of Papua New Guinea signed a loan agreement with the Asian Development Bank to fund a rural health services project covering 6 of the nation's 19 provinces. This project, which is the subject of this evaluation, is referred to as ADB-1 in this report. A second loan extending similar services to the remaining 13 provinces was signed in late 1985 and is referred to as ADB-2.

In mid-1985 the Government of the Independent State of Papua New Guinea asked the U.S. Agency for International Development (USAID) South Pacific Regional Development Office for assistance in evaluating the water supply and sanitation component of its ongoing rural health services project (ADB-1) supported by an Asian Development Bank loan. The Water and Sanitation for Health Project (WASH), responding to this request, fielded a two-person team to analyze project implementation activities and to recommend ways to improve performance. Joseph Haratani, a sanitary engineer, and James Baker, a financial analyst comprised the team. James Jordan, operations and maintenance specialist for the WASH Project joined the team during the last two weeks of the assignment.

The WASH team arrived in Port Moresby, the capital of Papua New Guinea on January 27, 1986. The team reviewed project-related documents and reports, interviewed health officials in the central office and in the six provinces covered by the project and visited villages and spoke with villagers where water supply and sanitation systems had been installed. The financial analyst completed his work on February 18, 1986. The team leader completed his work on March 14, 1986.

Based on its findings, the team presented oral briefings to the Department of Health and prepared a draft report before leaving Papua New Guinea. The draft report was submitted to USAID/Suva for initial review and comments. The team's major findings and recommendations are listed below.

Findings

1. The greatest shortcoming in project implementation is the lack of maintenance of water supply systems. This results in an unacceptable rate of system failures.
2. The problem of maintenance is closely tied to the lack of full community participation that is the result of the lack of a planned community development/promotion activity, a field in which the Department of Health has little experience or expertise.
3. A contributing cause to the above problems is that the water supply and sanitation activity has traditionally operated as a separate program and still remains organizationally outside the mainstream of the ADB-1 project and receives inadequate attention and support.
4. The officers in charge of the water supply and sanitation program are buried in the bowels of the provincial divisions of health and have no authority to make program planning or budgeting decisions.

5. The officers in charge have not been trained for the program planning, budgeting, managing, engineering, and accounting roles they are expected to perform.
6. Most of the necessary financial systems are in place but the rules governing their use are often ignored.
7. The existing financial systems are not designed to provide total costs on a project-by-project basis.
8. At the present rate of project implementation there will be a shortfall in expenditure of the water supply and sanitation budget.
9. Additional resources (health inspectors and vehicles) identified in the ADB-1 appraisal report have not been assigned or made available to the program on a full-time basis.
10. The decentralization of the government created a management vacuum which still has not been completely filled and is a constraint to effective project implementation.

Recommendations

1. The Department of Health should obtain the necessary manpower to train village caretakers and develop a maintenance management system.
2. The Department of Health should investigate and assess ongoing community development/promotion activities in Papua New Guinea and prepare a collaborative or separate community development/promotion activity for the water supply and sanitation program.
3. The water supply and sanitation program should be brought into the mainstream organization of the rural health services project, and all communications relating to the water and sanitation program should be channeled through the environmental health office.
4. The officers in charge of the water and sanitation program should be given status equal to the heads of other rural health services activities.
5. The officers in charge and selected health inspectors should receive additional training in program planning and budgeting, cost accounting, site surveying, reticulation system design and construction, and project management and supervision.
6. The Department of Health should provide additional guidance to provincial health staffs in the utilization of government financial systems as they relate to the ADB-1 project.
7. The Department of Health should develop and use a cost accounting system which will capture costs on a project-by-project basis.

8. The Department of Health should consider requesting an extension of the project to allow for the full utilization of budgeted funds.
9. The additional resources (health inspectors and vehicles) identified in the ADB-1 appraisal report should be assigned to the water supply and sanitation program on a full-time basis.
10. The Department of Health should bridge the remaining management gap by developing close personal working relationships with its provincial counterparts.

Chapter 1

INTRODUCTION

1.1 Description of Papua New Guinea

The independent state of Papua New Guinea (PNG) is located in the South Pacific just north of the northeastern tip (Cape York Peninsula) of Australia. Papua New Guinea consists of the eastern half of the island of New Guinea together with several major and many smaller offshore islands. The total land area is about 460,000 square kilometers (the size of the states of Oregon and Idaho combined) lying between 2 and 12 degrees south of the Equator.

The northern half of PNG (Papua) was controlled by Germany until World War I. The southern half (New Guinea) was a British protectorate and was placed under Australian rule in 1902. In 1914, Australia took control of Papua. In 1941, the Japanese invaded and took control of the island. After World War II, Australia resumed control and in 1946 the two halves were combined in an administrative union. Papua New Guinea gained its independence on September 16, 1975.

The population in 1983 was 3,260,000. Most of the people are Melanesians. The expatriate group consists of Australians, Asians, Europeans, and Americans. The official languages are Melanesian Pidgin and English. There are more than 700 local languages spoken.

The Owen Stanley Mountain Range which reaches an altitude of almost 15,000 feet divides the main island of Papua New Guinea into northern and southern regions. Since PNG is near the Equator, the climate of the low-lying coastal areas is tropical. Average annual rainfall ranges from 80 to 100 inches for most areas. However, the south coast below the capital, Port Moresby, lies in a rain shadow and receives as little as 40 inches or less annually. There are several large river systems. The largest being the Fly River which flows some 700 miles from the mountains of Western Papua through the plains and into the Coral Sea.

More than three-fourths of the population is rural and lives in a subsistence economy. The market economy is based on mining and tropical crops. Gold, silver, and copper are the major mining products and coffee, cocoa, and copra are its main agricultural crops.

1.2 Project Background

1.2.1 ADB-1

In November 1982 the Government of the Independent State of Papua New Guinea and the Asian Development Bank signed a loan agreement for a rural health services project covering 6 of the nation's 19 provinces. The provinces selected were Central, Gulf, Western Highlands, Madang, East Sepik, and West Sepik. The project was to be implemented by the Department of Health over a five-year period with a total budget of \$20 million. This project is referred to as ADB-1 in this report.

While the project's main thrust is in the provision of rural health services, the water supply and sanitation program plays a significant supporting role in achieving the project's goal of improving the health of the rural population in the project areas (see Logical Framework at end of text).

As project activities were getting underway in early 1983, the Government of Papua New Guinea put its decentralization plan into full effect, transferring most governmental functions from central offices to the provinces. Since the project was designed to be a centrally managed activity, this abrupt shifting of responsibility from the Department of Health to the provincial divisions of health created a management vacuum which seriously disrupted project implementation. The implementation of the water supply and sanitation program appeared to have suffered the most. Because of its separation from the mainstream of the rural health services program, the water and sanitation program received inadequate attention and support during this critical transition period and experienced serious implementation problems.

1.2.2 ADB-2

In late 1985, the Government of Papua New Guinea and the Asian Development Bank signed a second loan agreement which, in essence, extended the rural health services project activities of ADB-1 to the remaining 13 provinces. This follow-on project is to be implemented over a five-year period beginning in January 1986 and has a total budget of approximately \$20 million. This second rural health services project is referred to in this report as ADB-2.

Project details of both ADB-1 and ADB-2 were described in their respective appraisal reports prepared by the Asian Development Bank with the assistance of the Department of Health.

1.3 Evaluation Request and Purpose

The Government of the Independent State of Papua New Guinea sent a request to the U.S. Agency for International Development (USAID) in Suva, Fiji for assistance in evaluating the water supply and sanitation component of its ongoing rural health services project (ADB-1). USAID/Fiji relayed the request to the Water and Sanitation for Health (WASH) Project through the USAID offices in Washington, D.C.

WASH reviewed the scope of work and proposed a two-person team consisting of a sanitary engineer with experience in community participation and a financial analyst, both with considerable experience working in developing countries. The Government of Papua New Guinea approved the proposed team, and WASH began the process of preparing the team for the assignment.

The purpose of the evaluation is to investigate the status of project implementation of the water supply and sanitation program, determine its strengths and weaknesses, and recommend ways to improve its effectiveness.

1.4 Scope of Work

The WASH evaluation team was requested to perform the following tasks:

1. Review information relevant to ADB-1 and ADB-2.
2. Meet with staff from USAID and the Government of Papua New Guinea to clarify task requirements and gather information on the current and proposed water supply projects.
3. Meet with representatives of the Asian Development Bank to determine the level of their participation in and control over the ADB-1 and ADB-2 projects.
4. Visit a number of ADB-1-financed water supply schemes in Papua New Guinea to determine the current status of existing projects and to investigate ways of improving the success of these systems. Particular attention is to be paid to the following:
 - level of community participation in system construction and operation
 - need for rehabilitation
 - current techniques for system operation and maintenance
 - effectiveness of project administration
 - assessment of use of project funding
 - assessment of effectiveness of design and construction criteria and methods.
5. Recommend steps to take to restore ADB-1-funded water and sanitation projects to acceptable levels of operation.
6. Recommend methods and procedures for improving participation by the communities in water projects.
7. Recommend methods to improve the design and construction of ADB-2-funded projects.
8. Recommend cost control techniques to enable the Government of Papua New Guinea to use ADB-2 funds more efficiently.
9. Recommend a maintenance program for water supply schemes in rural Papua New Guinea.
10. Recommend appropriate pilot projects that would be used to test the effectiveness of the recommendations made in items 5-9 listed above.
11. Recommend types of training programs needed to assist the government to achieve the goals of ADB-2-funded projects.
12. Prepare a draft report for USAID/Fiji describing the findings and recommendations resulting from the consultants' visits. A copy of this report is to be left with the mission prior to departure from the country.

1.5 Consultants' Activities

After receiving and reviewing project documents, the consultants traveled to WASH headquarters in Arlington, Virginia, for briefings and meetings with persons knowledgeable about the project and about Papua New Guinea.

On January 20, 1986, the consultants traveled to the Philippines where they received briefings from representatives of the Asian Development Bank, the World Health Organization (WHO), and UNICEF in Manila. From there they traveled to Papua New Guinea arriving in Port Moresby on January 26, 1986. The following day they met with ADB-1 project coordinator, Jane Thomason, who provided them with additional information and scheduled meetings with members of the ADB-1 Project Implementation Unit and other health officials (see Appendix A).

After their first round of meetings, the team met with the DOH/PIU to review and agree upon the scope of work for the evaluation. On Friday, January 31, the team visited rural villages in Central Province where water supplies had been installed under the ADB-1 project. This field trip in Central Province was followed by a series of trips to each of the six provinces covered by the project. The two team members traveled together on the first set of visits to the provinces to meet with health and finance officials. After these first visits, the financial analyst prepared a draft of the financial sections of the evaluation and made an oral presentation of his findings to the Department of Health. He left Papua New Guinea on February 18, 1986.

The team leader continued his visits to the provinces inspecting village water supply and sanitation installations (see Appendix B). On March 10, 1986, he made an oral presentation of his findings to the Department of Health. After preparing a draft evaluation report, he left Papua New Guinea on March 14, 1986, and traveled to Suva, Fiji, to submit the report to Dr. Patrick C. Lowry, of USAID/Suva for review and discussion. He left Suva, Fiji, on March 18, 1986, to return to the United States.

Chapter 2

OVERVIEW OF SECTOR

2.1 Government Institutions in Papua New Guinea

There are three government agencies involved in the water supply and sanitation sector in Papua New Guinea. The National Water Supply and Sewerage Board (the Water Board) which was established in 1982 has overall responsibility for the sector. In reality, however, the water board has assumed responsibility only for the national capital district and several provincial capitals. The water board has delegated the responsibility for the design and construction of water supply and sanitary installations of other urban centers to the local government engineers section of the Department of Works and for rural villages to the Department of Health (see Appendix C, D, and E.)

With the decentralization of the Government of Papua New Guinea in early 1983, the major role of both of these agencies has been one of providing guidance and assistance to provincial governments, which are now directly responsible for all government operations in their respective provinces. Since provincial governments do not have technical expertise in this sector, they look to the national offices for technical assistance and support.

2.2 External Assistance

Direct and indirect bilateral assistance to the sector is provided by Australia, the Netherlands, and volunteers from the United Kingdom, Canada, and the United States. Among the U.N. agencies, the U.N. Development Program (UNDP) and WHO have been actively involved in supporting water supply and sanitation activities. The Asian Development Bank has been a major donor to the sector in both the urban and rural areas.

Chapter 3

FINDINGS AND CONCLUSIONS

3.1 General

The Department of Health and Project Implementation Unit staffs are aware of the major problems encountered during the implementation of ADB-1. Many of these problems have been addressed in the appraisal report for ADB-2 as shown in Table 1 below.

Table 1

ADB-1 Problems and ADB-2 Provisions

| <u>ADB-1 Problems</u> | <u>ADB-2 Provisions</u> |
|---|---|
| 1. Lack of maintenance of water systems. | 1. Training of village caretakers. |
| 2. Lack of community participation. | 2. More specific village participation requirements and provision of short-term consultant. |
| 3. Rapid failure of handpumps. | 3. Installation of the improved PNG handpump. |
| 4. Lack of comprehensive village selection criteria. | 4. Expanded list of village selection criteria. |
| 5. Inadequate design and construction of water systems. | 5. Training of health inspectors. |
| 6. Increased provincial responsibilities resulting from decentralization. | 6. Increased staff training. |

There were other problems, such as the isolation of the water and sanitation component from the mainstream of the rural health services project and the lack of complete cost accounting for individual water system installations, which were sensed by but not clearly identified by the staffs. These as well as other issues are discussed in the following paragraphs.

Of the various problems identified in the evaluation, one clearly dwarfs all of the others. This is the problem of operation and maintenance of water systems. This is such an overriding issue that even if all other problems had

been resolved, there would still be no hope of providing improved water supplies to an increasing percentage of rural villagers as planned in this project. The need to attack and solve the problem of operating and maintaining water systems cannot be overemphasized.

Another important issue of a general nature concerns the utilization of locally available resources. The evaluation team noticed many instances in which existing resources were not being fully utilized. These observations ranged from very minor items such as the absence of project location wall maps, to major items such as the low utilization of the local government engineers section in the design and construction of reticulation systems. In other areas, such as community development and promotion, the knowledge and experience of other groups working in Papua New Guinea could be helpful to the Department of Health.

Finally, there is a wealth of information and experience within the health sector itself which is not being fully utilized. In each of the six provinces visited, the team was impressed by some innovative action taken by the staff to solve a problem. These actions ranged from the use of baseline data from the old Department of Lands' village water supply survey in East Sepik to the hiring of a bookkeeper under the unrestricted category of 'casual laborer' in Gulf Province. However, due to the lack of communication among provinces, none of these ideas had been disseminated or replicated. Although the team was not asked to assess the existence and utilization of local resources, these random observations point to the need for further investigation of these resources.

3.2 Project Resources

3.2.1 Human and Material Resources

In his report prepared for the Asian Development Bank in 1982, McGarry (9) described the human and financial resources existing in each of the six provinces involved in ADB-1 and the levels of water supply and sanitation activities being carried out by these provinces. Table 2 below shows the types and numbers of staff working in water supply and sanitation in 1982.

The ADB-1 appraisal report (2) enumerated additional staff and material resources which were to be made available to the water supply and sanitation program under the rural health services project. These resources are shown in Table 3 below.

Information obtained from the provinces indicates that the additional resources identified in the ADB-1 appraisal report have not been assigned or made available to the water supply and sanitation program on a full-time basis. While there are other problems which reduce the effectiveness of the program, the limited number of technically qualified staff now working in the water supply and sanitation program limits the size of the program. The hiring of the four health inspectors and two assistants identified in the appraisal report would by itself double the number of technical staff working full-time in the program. This action would allow a significant expansion of field activities by providing manpower to supervise additional construction teams whose members can be hired without needing to establish new positions.

Table 2

Provincial Water Supply and Sanitation Staff in 1982

| | <u>W. Sepik</u> | <u>E. Sepik</u> | <u>Madang</u> | <u>W. Highlands</u> | <u>Gulf</u> | <u>Central</u> |
|-----------------------------|-----------------|-----------------|---------------|---------------------|-------------|----------------|
| Provincial Health Inspector | 1 | 1 | - | 1 | 1 | - |
| Health Inspector | 1 | 1 | 1 | 1 | 1 | 1 |
| Health Inspector Assistant | 2 | 2 | 2 | 3 | 1 | - |
| Artisan Laborer | - | 2 | - | 2 | - | 2 |
| | - | 3 | 6 | - | 2 | 2 |

Table 3

Additional Resources for the Water Supply and Sanitation Component

| <u>Resource</u> | <u>Central</u> | <u>Provinces</u> | | <u>Madang</u> | <u>W. Highlands</u> | <u>W. Sepik</u> |
|-----------------------------|----------------|------------------|-------------|---------------|---------------------|-----------------|
| | | <u>E. Sepik</u> | <u>Gulf</u> | | | |
| Health Inspectors | 1 | - | - | 1 | 1 | 1 |
| Health Inspector Assistants | - | - | - | 1 | 1 | - |
| Artisans | - | - | 2 | - | - | 1 |
| Laborers | * | 8 | * | 5 | 4 | 5 |
| Vehicles | 1 | 2 | 1 | - | 1 | 1 |
| Drivers | 1 | 2 | - | - | 1 | - |
| River trucks | - | 1 | - | - | - | - |
| Dinghies | - | - | 2 | - | - | - |
| Outboard motors | - | 8 | 2 | - | - | - |
| Warehouses | - | - | 1 | - | - | - |

*Numbers not specified in the ADB-1 appraisal report.

Within the Department of Health, the environmental health section is staffed by the assistant secretary and a senior health inspector. While vacancies are reported to exist in this section, they are designated for specialties other than water supply and sanitation. Because of the critical need for additional senior staff in this section, every effort should be made to overcome existing hiring constraints. In order to close the existing communications gap vis-à-vis the provinces through more frequent field visits, as a minimum, it will be necessary to double the present two-person staff.

3.2.2 Financial Resources

The ADB-1 appraisal report does not identify annual budget allocations by province for the water supply and sanitation program. However, the memorandum of understanding between the Department of Health and the provinces provides a uniform budget allocation of Kina 60,000 per province per year. This allocation level did not take project contingencies or inflation into consideration. Therefore, a shortfall in loan drawdown has been built into the implementation plan. Details of the financial aspects of the water supply and sanitation activity and their implications are fully described in section 3.5 of this report.

3.3 Project Management

3.3.1 Administration

The Department of Health is the executing agency for the project. Within the department, a project implementation unit has been established with the secretary of health or his designee as project manager. He is assisted by three long-term consultants, a project coordinator who is directly responsible for the day-to-day supervision of the project, a project accountant, and a procurement officer. The unit is supported by a number of other long-term and short-term consultants. Long-term consultants include a health educator, two management consultants, and a sanitary engineer (see Appendix F).

While the project coordinator has the responsibility for the day-to-day supervision of the total project, the main burden for the implementation of its water supply and sanitation component falls on the environmental health section of the Department of Health. As noted above, the environmental health section is staffed only by the assistant secretary and one senior health inspector who are assisted by a sanitary engineering consultant. The section has vacancies which the Department of Health has not been able to fill.

There appear to be three major constraints to hiring needed staff. The first is the need to obtain approval of the Public Service Commission for the desired position. The second is the need to find suitable candidates within the limited manpower pool who are willing to accept existing living and employment conditions in Port Moresby. The third constraint, which has frustrated many hiring efforts even when the first two hurdles had been overcome, is providing housing for the successful candidate. The problem of housing is so acute in Port Moresby that, in reality, recruitment for additional staff cannot be initiated until housing is secured for the prospective employee.

During the first three years of ADB-1, the lack of housing was not the key constraint in recruiting consultants for the project. Since few, if any, expatriates were willing to come to Papua New Guinea or were acceptable to the Public Service Commission, all of the consultants hired already lived in Port Moresby housing. However, it is unlikely that candidates will continue to be found locally. The limited pool of technically qualified candidates has been virtually depleted.

3.3.2 Effects of Decentralization

The Government of Papua New Guinea put the full force of its decentralization plan into effect in early 1983 just as the implementation of ADB-1 was being started. In effect, this action transferred the authority for project implementation from the Department of Health to each of the six provincial divisions of health covered by the project. Since the project design had included no provisions for this eventuality, the Department of Health and the Project Implementation Unit were left with the responsibility for the overall and day-to-day supervision of the project with no direct implementation authority.

Under the decentralized administration, the executive authority of the Department of Health is largely limited to establishing policies and guidelines for health sector activities. Thus the department and its implementation unit find themselves in the delicate position of being responsible to the Asian Development Bank for project execution without the legal authority to directly manage project implementation. The Project Implementation Unit's remaining authority for project control is the reporting requirements set forth in the project loan agreement, which the provincial divisions of health tacitly accept.

In addition to monitoring the periodic progress and financial reports, the Project Implementation Unit has issued circular memoranda which describe project policies and provide implementation guidelines to the provincial divisions of health. Most recently, the unit published the first issue of its newsletter, "The Wetline," which contains specific articles dealing with the implementation of the water supply and sanitation program. One of the purposes of the newsletter is to foster two-way communication between the Department of Health and the provinces on topics of concern to the officers in charge and other staff in the water supply and sanitation program.

Perhaps the most effective management tool now available to the Department of Health is the "field visit" to the provinces and out into the villages where the products of project implementation can be seen. Besides allowing department staffs to observe field activities, the field visit provides them the best opportunity to develop a close personal relationship and build a collegial working rapport with their provincial counterparts. This type of relationship is absolutely essential to operate successfully in a decentralized administration. During the team's field visits, this collegial rapport was evident between the project coordinator and the provincial assistant secretaries of health. The same level of interpersonal contact must be attained by each of the relevant Department of Health and Project Implementation Unit staff. A high level of mutual respect and trust is the key to closing the communications gap resulting from decentralization.

3.3.3 Organizational Status of the Water Supply and Sanitation Component

A review of the five provincial organization charts obtained shows that the chain of command for the rural health services component of the project involved only two or three organizational levels, while the water supply and sanitation component involves from four to six (see Appendix G). In effect the water supply and sanitation program is buried deep in the bowels of the provincial health organizations with practically no authority for making program decisions and receiving inadequate attention and support. What recognition the officer in charge receives comes in the form of demands from the hierarchy to report on his accomplishments on a periodic basis. He is not given the respect he deserves for the key role he plays in the project.

With the decentralization of the government, the main advocate of the officer in charge in the Department of Health, the assistant secretary for environmental health, has, for all practical purposes, become an inaccessible resource. The organizational status of the water supply and sanitation program must be enhanced and the lines of communication with the Department of Health strengthened if significant improvements in project implementation are to be achieved.

3.3.4 Project Monitoring

Project activity information now being received by the Department of Health is limited to the reports submitted by the provinces as required by the Asian Development Bank. In essence, these reports provide detailed information on the quantity of project activities but little or nothing on their quality. For example, the number and types of water supply systems installed, the number of latrine slabs issued, and the number of systems repaired or rehabilitated are reported. Also detailed accounting of funds expended for commodities, transport and travel are submitted. Two provincial officers in charge have described problems encountered in project implementation but there is no evidence of any response or action taken in these two instances. Generally, too little information concerning project implementation, such as village participation, system design or commodity procurement, has been provided to the Department of Health and the Project Implementation Unit to allow for the proper monitoring of the project and to provide the level of assistance and support needed to improve project performance.

3.3.5 Logistics

The logistical systems of Papua New Guinea are an anomaly. Its air transport system covers the entire country through a network of hundreds of airports and landing strips which provide fast but expensive access to all but the most rugged mountain regions. On the other hand, the existing road systems are nothing more than scattered local networks for limited interprovincial but no national travel. Most provincial capitals are serviced from the national capital by jet aircraft but none can be reached by paved roads.

This unique combination of logistical systems makes the transportation of men, goods, and materials either an expensive or time-consuming business or both. Since transport by air is several times as expensive as by road and water

transport several times slower than by road, the lack of a national road network places severe constraints on project implementation. ADB-1 provided no guidelines for project site selection relating to transportation costs. As a result of this lack of policy, the cost of air transport far exceeded all other costs in the installation of a water supply in West Sepik Province. Although it is not likely that this misapplication of funds will be repeated, there is a need to establish guidelines which address this unique logistics situation by giving priority to villages with easy access or by setting some limits on transportation costs.

The establishment of any guidelines to address existing logistical constraints must take into consideration the equitable distribution of project services. Because of differences in accessibility and, therefore, transportation costs, it is inevitable that a policy favoring equitable distribution of services will be in conflict with a policy for providing water supply and sanitation services to the largest number of people with a given budget. Because of this conflict between egalitarian and economic goals, the Department of Health will have to reach some compromise in setting its village selection criteria.

3.4 Project Activities

3.4.1 General

The Water Supply and Sanitation Component of ADB-1 placed emphasis on making installations at government health facilities and schools. Prior to ADB-1, the Department of Health built rural water supplies without community participation. With the beginning of ADB-1, community participation was sought. One of the first problems faced by the ADB-1 water supply activity was that there existed no current province-wide data on village water supplies and, in most cases, provincial staff was unaware of existing data from village water supply surveys conducted from 1966 to 1972 by the Department of Lands and Surveys. In spite of the lack of this basic planning information, province staff, responding to program requirements, prepared annual lists of government facilities and villages where water supplies were to be installed. Although these lists were not based on any set selection criteria, in some provinces an effort was made to target the installation of water supplies to sites on the lists. In other provinces the actual water supply sites had little or no relation to those listed. Such was the rudimentary level of program planning efforts in the ADB-1 water supply and sanitation activity in most provinces. In spite of these constraints, some 120 to 180 water supply systems are estimated to have been built, and some 100 to 150 have been repaired or rehabilitated. Unfortunately, a significant percentage (perhaps 20 to 30 percent per year) of these hard-earned gains are being lost due to the lack of proper maintenance of the systems.

3.4.2 Baseline Data Collection

In the late 1960s and early 1970s the geological section of the Department of Lands, Survey and Mines (now the Department of Lands) conducted surveys of village water supplies in most, if not all, of the nation's 19 provinces (see Appendix H). Although dated, these surveys provide useful background information -- such as location maps, means of access, water uses, water system

sketches, recommendations for improvement, and, in some cases, photos. (See Appendix I for a sample survey.)

Since 1983, three provinces (Central, Eastern Highlands, and East New Britain) have completed new village water supply surveys covering significant portions of their population. These surveys are based on the WHO village water supply questionnaire. Of these three, Central is the only province covered by ADB-1 which has published the results of its survey. (The survey covers 40 percent of the population.) East Sepik plans to complete its data collection in April 1986. West Sepik has already sent some data to the Department of Health and plans to cover Lumi, Aitape, and Luku Districts beginning in March 1986. Western Highlands Province collected data on 50 villages in mid-1984 and submitted the results to the Department of Health.

While these surveys are very valuable, they require well-trained surveyors to obtain reliable data. They also require many man-months of work and siphon off manpower at a time when the limited human resources of the provinces need to focus on constructing water systems. In East Sepik, the staff is utilizing data from the village water supply surveys performed by the Department of Lands, Survey and Mines in 1966 as a basis for project site selection. Using these old surveys (with some updating) could temporarily postpone manpower needs for surveys, increase the number of project completions per year, and reduce the shortfall in project expenditures. Where surveys are already in progress, however, they should be continued but they should use as much outside manpower as possible.

3.4.3 Program Planning

Program planning in the water supply component has consisted of little more than a listing of candidate villages and their populations, the type of water systems proposed, and approximate costs. These lists were developed without any firm basis for estimating the length of time required to complete each project and, therefore, were over-optimistic. As a result, none of the annual construction program targets were met.

Over the three years of ADB-1 operation, the officers in charge have become more knowledgeable about their project installation capacities and have scaled back their annual estimates. However, there is still a tendency to over-estimate their production rates. This is understandable in view of the lack of program planning tools (e.g., standardized estimates of man-days required by type of project, lead time for commodity procurement, mobilization time, and community promotion requirements) and a lack of training in program planning.

3.4.4 Community Participation

The water supply and sanitation component of ADB-1 gave priority to new and existing health facilities and schools as sites for water supply and excreta disposal projects. Since these were government institutions and villagers were not the direct beneficiaries, no village participation was required or planned. However, water supplies were also built in rural villages and, in these cases, the Department of Health asked villagers to participate directly in the program by contributing labor, local materials, team accommodations,

local transportation, and money. The level of participation varied from village to village. In the best circumstances, villagers participated fully. In others the promises of participation were not kept. In some of these latter cases, the systems were built without village participation and in others the project was withdrawn.

Based on the limited sample of villages visited and systems inspected, it appears that where there was full participation in the construction of projects, the villagers continued their participation in the operation and maintenance of the system. This was generally the case in Tambul District, Western Highlands Province, where villagers are maintaining their systems within the limits of their abilities. At the other extreme, where there was no village participation in construction, there appears to be no interest in the operation and maintenance of the systems, even to the extent that villagers do not report system failures to representatives of the provincial divisions of health.

The importance of village participation in contributing to the success of rural water supply projects is well known in the Department of Health and in other government agencies operating in this sector. No government, including the Government of Papua New Guinea, can afford to build and continue to rebuild and replace rural water systems in the nation every few years. Unless villagers are willing to participate not only in the construction but, more important, in the operation and maintenance of their water supply systems, there is no hope of making any lasting progress in extending water supply services in rural areas.

Experience in Papua New Guinea and elsewhere with village participation indicates that the earlier villagers are brought into the project process and made aware of their short-term and long-term responsibilities, the greater the chances for keeping them involved over the long-term. In cases where water supplies have been built without village participation, it is next to impossible to convince villagers that they are responsible for operating and maintaining the system once it is completed.

Recognition by water supply and sanitation personnel of the need for full village participation and the establishment of village participation criteria in the selection process represent major steps toward resolving this critical problem. What is now needed is a community development action plan designed to promote full community interest and participation.

3.4.5 The Role of Women

A glaring omission in project planning and in project implementation is the role of women in the water supply and sanitation program. Women are the main purveyors and users of water in the household. They are the most knowledgeable about water- and sanitation-related practices, taboos, and preferences. Their knowledge and views should be sought and utilized in the program.

For example, women's preference for one type of pump over another can be crucial to the success or failure of a project. During visits to project villages, the team was told that women preferred to use handpumps having lever-action handles because the modified PNG handpump made their backs ache.

This information seemed to explain at least in part the team's observation that PNG handpumps were not being used regularly.

Another area where women's knowledge and preferences need to be considered is in excreta disposal practices, especially relating to infants and children. Women are almost exclusively responsible for the care of children and therefore have first-hand experience and knowledge of taking care of their biological needs. They are the experts in this area, and their ideas and views should be taken into consideration in planning and implementing project activities.

There are various women's groups organized in many districts and villages. One of these groups is the Country Women's Association. There are also other groups sponsored by church and other non-governmental organizations. These groups are a resource which need to be explored and utilized in the water supply and sanitation program. In addition to providing information reflecting women's viewpoints, they can play a significant role in supporting community development and promotion activities which form the basis for both short- and long-term community participation in the program. Where women's groups do not exist or are ineffective, the Department of Health should explore ways to establish such groups and support them, either directly or indirectly, through other governmental or non-governmental organizations.

3.4.6 Village Site Selection

The appraisal report for ADB-1 stated that an initial survey would be conducted to "determine the accessibility and quality of the water supply and sanitation facilities currently available in the rural areas served by the project. This survey will be the basis for a regular monitoring of improvements in water and sanitation facilities as a result of project activities."

Although the appraisal report provided no village site selection criteria or guidelines, it provided for a sanitation engineer consultant "to organize the water and sanitation sector program and provide ongoing technical assistance."

Since neither of these two provisions was carried out at the beginning of the project as envisioned, provincial officers in charge were left to their own devices in selecting village sites. At times, political pressure was put on the officers to include favored villages. It is not known to what extent the site selection process was influenced by political interests although the officers in charge stated that they were able to deny such requests or shunt them to other provincial offices.

Regardless of how the villages were selected, most, if not all, of the recipient villages visited did need improved water supplies. Unfortunately, many of them have been forced to go back to their traditional sources of water because of system failures.

3.4.7 System Design and Construction

Water Supplies

During the first three years of ADB-1 implementation, the water supply and sanitation program has encountered a host of design, construction, and operation and maintenance problems. The most persistent of these has been the rapid failure of traditional handpumps. Other problems included the loss of stored rainwater due to tank leakage, worn or broken taps, or taps left open. Gravity reticulation systems have suffered from land slides which plugged intake structures, worn taps, pipeline failures, or leakages due to faulty workmanship or excessive pressure.

The Department of Health is well aware of these problems and has begun to resolve them. The most promising of its actions has been the decision to install the modified PNG handpump as the handpump of choice where environmental conditions warrant its use.

Based on the limited financial information available, it seems that the initial investment cost of all types of water supply systems, except pumped reticulation systems, falls within an acceptable range. The reported costs of materials appear to be consistent and reasonable. However, costs for labor, per diem, transportation, or overhead costs have not been broken out project-by-project at the present time. A financial system designed to capture these costs will have to be established so that they can be monitored and controlled.

Three other problems require attention:

1. **Improper siting and construction of dug wells.** Some wells seem to have been located at a low point in the terrain, where groundwater was assumed or known to be close to the surface, rather than at a location more convenient to the users and less subject to surface or subsurface contamination. Also, some well-liner joints were not watertight and surface water was infiltrating into the well.
2. **Improper design and construction of reticulation systems.** Problems include selection of sources which are, or may soon become, subject to fecal contamination or which may not produce enough water during the dry season. Improper sizing of pipe, lack of pressure breaks or pressure-reducing devices, and inadequate cover over pipelines are also common problems.
3. **Acquisition of land and rights-of-way.** Some water supply projects were delayed because the use of land and rights-of-way were not obtained before construction was started.

Table 4 on the following page presents a summary of ratings of water supply systems visited.

Table 4

Summary Ratings of Water Systems Visited

| <u>Ratings</u> | <u>Handpumps</u> | <u>Rainwater Tanks</u> | <u>Reticulation</u> |
|----------------|------------------|----------------------------|---------------------|
| Good | 11 | 14 | 9 |
| Fair | 3 | 1 | 7 |
| Poor | 1 | - | - |
| Not operating | 4 | 2 | 8 |

The figures in the above table would lead one to conclude that the best type of system is rainwater catchment and the worst reticulation. The first conclusion is basically correct; however, the second is not correct. This becomes apparent when the additional background data presented below are considered.

Handpumps: Five of the eleven handpumps rated "good" and one of the three rated "fair" are recent replacements (1985 and 1986) of handpumps which had failed. When we add these failures to those found "non-operating," we find that there were actually ten handpump failures, rather than the four, among the 19 handpump sites visited. In other words, there were handpump failures at half of the sites in the past year. This failure rate agrees with observations made earlier by McGarry (9) and by Sell (17).

Rainwater Tanks: All 17 tanks in the 9 systems visited were found to be in good condition. One had recently been repaired where someone had broken the tap loose from the tank (see Photo 25). The number of tanks shown is larger than the number of systems because of the existence of multiple tank systems. The one tank rated "fair" was in good condition but had been improperly installed so that most of the stored water could not be utilized. The two tanks rated as non-operative were also in good condition, but the semi-rotary handpump used to raise the water to a roof tank was out of order, thus putting the tanks out of operation. Since all of these systems had been installed from 1983 onward, they have not yet reached the age (five years or more) when rainwater tanks reportedly start to fail; therefore, this may not be a valid sample.

Reticulation: Of the 24 completed reticulation systems visited, all 8 of the systems found to be "non-operating" were pumped systems located in Central Province. Until this year, all of the systems installed in Central Province with ADB-1 funds were designed and installed by the Central Province Division of Policy and Planning and not by the Provincial Division of Health. Because of their poor design and construction, these systems should be eliminated entirely from the ratings. Three other reticulation systems visited were built prior to the ADB-1 project and also should be eliminated from the ratings. This leaves nine systems rated "good" and four rated "fair" which places them above handpumps in performance and durability.

Priority by System Types: In the team's judgment, gravity reticulation systems should be the system of choice wherever hydrogeological and hydraulic conditions suitable for their use exist. They require no mechanical equipment to operate and can be designed to allow for the placement of a large number of taps at locations of maximum convenience to the users. Although this type of system costs more initially than handpumps or rainwater tanks, this disadvantage is outweighed by the larger volume of water delivered, the larger number of villagers served, and a longer operating life.

Based on observations made during village visits, the evaluation team concluded that pumped reticulation systems are not appropriate for rural villages in Papua New Guinea at the present time. As noted above, none of the eight systems inspected was delivering water for one reason or another. Not all of the failures were related to pumping equipment problems. Several were due to poor system design and, in two villages, to vandalism of the public taps reportedly resulting from frustration with systems that did not provide the water service expected (see Photo 26). The solar panels inspected seemed to be working well although there were some signs of possible deterioration. One windmill was found to be pumping satisfactorily but another had a broken wooden pump rod.

The evaluation team had the villagers at Gabagaba start up their diesel-engine driven pump. While the system was found to pump water, it was also noted that the crankcase oil had not been changed in a very long time. Other engines inspected exhibited the same lack of preventive maintenance work.

Because of the numerous problems encountered in the design, operation, and maintenance of pumped reticulation systems, they should not be installed in rural villages except where there is no other feasible alternative. In those situations, special efforts must be made to hire or train a competent mechanic paid by the village to operate and maintain the system.

Second priority should be given to rainwater catchment systems. Where rainfall rates are high and evenly spaced throughout the year with short dry spells, rainfall catchment systems can be designed as the primary or only source of potable water. Where such favorable rainfall patterns do not exist, rainwater catchments may not be feasible as a primary or sole water source. In these cases, they should be designed for restricted use or as an emergency water source, and other types of water supply systems -- for example handpumps -- should be considered as a primary source of water.

Handpumps, because of their poor endurance record, should be the last choice. With the introduction and testing of the improved PNG handpump, this order of priority could change, but for the present handpumps should be considered only where other types of systems are not feasible.

Sanitation Systems (Latrines)

Priority was given to health facilities and schools in ADB-1 as sites for installing water supply and sanitation systems because it was thought that they would demonstrate appropriate models which villagers would want installed in their own villages.

Rainwater catchment systems were installed at most of the health facilities and schools. In a few sites, a handpump or a reticulation system standpipe was provided. Most of the water systems visited at health facilities and schools were functional and, in general, did present positive models of appropriate technologies.

The status of excreta disposal systems installed at health facilities and schools is quite a different case. Most of the latrines were of traditional construction rather than the flat concrete slab being fabricated by the provincial health division's water supply and sanitation staff. These latrines were of two types. The more rudimentary type consisted of a dug pit covered across the top with a series of small-diameter poles placed side by side, but with a gap of from 15 to 20 centimeters near the centerline of the pit. These poles were then plastered on top with mud to form a level surface for placing the feet. The more elaborate type was built of sawn lumber with a floor and bench seat over the pit, exactly the same design as the traditional pit privy found around the world. Both had superstructures built of a variety of materials ranging from pit-pit (a local name for bamboo-like grass) stalks and split bamboo to sawn lumber and corrugated galvanized sheets. A relatively few concrete slabs, some fitted with a prefabricated plastic bowl, were seen.

All of these latrines had the expected odor problem, some worse than others. School latrines were the most noisome -- probably because of heavy use. At health facilities, latrines (and flush toilets) reserved for staff use were usually the cleanest. The condition of patient and public facilities ranged from bad to unusable because of lack of maintenance (flushing and cleaning). They have thus become negative demonstration models. Concrete slabs are harder to keep clean than wooden bench seats, therefore, the latter type should be given consideration as an alternative to the slabs now being fabricated.

It appears that most villagers don't believe that excreta disposal "in the bush" is a problem. In fact, where population densities are low and disposal "in the bush" is done in prescribed areas outside of the watersheds of water sources, the dangers of fecal contamination may not be very great. "Bush disposal" becomes a problem where population densities are high and where villages begin to encroach on the watersheds of water sources. In these situations, villagers may be more aware of possible contamination problems and more receptive to health education messages dealing with feces-related disease cycles. Until these relatively sophisticated health concepts are understood and acted upon by villagers, it may be more productive to focus the sanitation activity on personal hygiene, handwashing, and the use of soap rather than on the installation of a less than ideal latrine.

Villages visited were found to be relatively clean and free of deposits of human feces although pig droppings were in evidence, especially in the highlands. Along the coast, beach-side latrines overhanging the ocean are commonly used.

3.4.8 Turnover of Water Systems

Some of the project provinces have developed standard forms for use in the water supply and sanitation program. These forms include a village application form, a project proposal fact sheet, and a project completion certificate (see

Appendices D, J, K, and L). At the present time, however, the ADB-1 project provides no guidelines or instructions for the vital act of turning the water supply system over to the villagers. Once the system is built and a certificate of completion is signed, the system should be released by the province and officially accepted by the village water committee to operate and maintain. The transfer of ownership to the village should be formalized into an official government act that will remind the villagers of their continuing responsibility for the operation and maintenance of the system.

In many of the villages visited, someone in the village, either a water supply committee member or a village leader, had assumed responsibility for the system. In some of these same villages, however, the system had either failed completely or had developed some deficiencies and no action had been taken to make repairs or even to report the problem to a health representative. In villages where no one had assumed responsibility, the water supply systems received no maintenance and were malfunctioning or were out of service.

Although a water supply system, such as a handpump, may seem insignificant to people who are accustomed to higher levels of service, it can represent a major step toward improving health conditions in a village and should be given the serious attention it deserves. The act of transferring ownership of the system provides the opportunity to focus attention on its significance on the lives of the villagers.

3.4.9 Operation and Maintenance

Many water supply projects in developing countries fail to function as designed because provision for effective operation and maintenance of the systems is not made during the planning stage.

Operating and maintaining a water supply system in rural communities requires close coordination between the agency responsible for water and the users. This is particularly true when the community is (or should be) directly involved in the operation and maintenance of the water systems.

The design of an appropriate maintenance program for village communities must be specific to the country in which it will be implemented. Every well-planned maintenance program, however, will address the seven key elements of maintenance discussed below.

1. Institutional: Both the government agency responsible for water and the village(s) receiving an improved water system need to be actively involved in the water project.
2. Tools and skills: One key to ensuring effective water system maintenance is to make certain that responsibilities for maintenance are clearly defined before the project is started and that those who will perform maintenance have the necessary tools and skills.
3. Spare parts and supplies: Even the simplest water supply systems require that spare parts and supplies be available to keep the system in good operating order.

4. Logistics: In order for the government to take care of those parts of the water system for which it is responsible, it must have reliable transport.
5. Finance: Before a water system is designed, the system planner must be certain that the government and, particularly in Papua New Guinea, the village can afford to maintain the water system.
6. Recordkeeping: Good recordkeeping needs to be a part of all water supply programs. In Papua New Guinea, maintenance records are needed to enable project managers to
 - o determine spare parts/supplies needed for maintenance;
 - o prepare maintenance budgets; and
 - o determine how well the water systems are operating.
7. Training: Maintenance training programs are needed for all types of water systems. In Papua New Guinea, it is especially important to recognize that the villages receiving water systems must be adequately prepared to take care of their new systems.

These seven elements form the basis for developing an effective maintenance program, and the recommendations in this report with respect to water system maintenance in Papua New Guinea will rely upon these key elements.

The awareness of the need for proper water system maintenance is growing in Papua New Guinea. This realization, however, is primarily within the Department of Health rather than at the village level. Since much of the water system maintenance should be the responsibility of the village itself, the development of an effective maintenance program should be directed toward the village people.

Currently, the maintenance of water systems in rural Papua New Guinea tends to be ineffective. Villagers are supposed to be responsible for some funding and performing minor maintenance work, while provincial level officers in charge are supposed to handle major problems. For example, the repair of taps is the responsibility of the villagers, while a break in the main water line should be repaired by provincial personnel.

However, in reality, the officer in charge often has incomplete information concerning maintenance complaints. Because reporting is inconsistent, it is difficult to ascertain the operation and maintenance status of the rural water systems.

Also, villagers are usually not aware of their responsibilities, and frequently haven't the tools and skills needed to maintain their systems. Furthermore, the villagers are generally not aware of how to handle major maintenance problems. Often the problems are not reported to the health authorities. Consequently when a water system fails, repairs are not completed for lengthy periods of time, if at all.

Ineffective maintenance of water systems threatens the accomplishments made by the Department of Health in providing improved water systems to rural Papua New Guinea.

The following are findings relating to the seven key elements of maintenance described above:

1. Institutional: Prior to ADB-1, villages were not actively involved in water system construction. They were not required to contribute funds for the materials or equipment used to construct the water system in their village. Even under the ADB-1 project, village participation is spotty. Therefore, villagers do not develop a sense of "ownership" of the system. They are generally informed that they are responsible for maintenance, but the officer in charge or the construction teams have not instructed the villagers on the steps they should take to implement a maintenance program within their village.
2. Tools and skills: While the health inspector does have the skills and tools needed to maintain water systems, the villagers generally do not. In addition, they are generally unsure of their responsibilities in this respect.
3. Spare parts and supplies: The spare parts and supplies needed to repair rain catchment and gravity systems fed from streams or springs are generally available at the provincial level. However, repair parts for imported handpumps and diesel-driven units are much more difficult to obtain and are often unavailable. The modified PNG handpump could represent an alternative to the use of imported handpumps, but attention must be paid to social and cultural resistance to its use. Women prefer handpumps with handles rather than the PNG pump.
4. Logistics: Transport and travel are generally available for use by the officer in charge. Maintenance, however, is accorded secondary status when decisions are made on how these vehicles are to be used. Time and transport need to be specifically set aside for maintenance purposes.
5. Finance: Villages can generally afford and are willing to fund the cost of repairing water systems. This includes spare parts and tools. It will not be possible for the Government of Papua New Guinea to sustain the cost of maintaining rural water systems without village support.
6. Recordkeeping: Program managers and others concerned with maintenance activities do not currently have information necessary to determine either the cost of or the resources expended on maintenance.
7. Training: The three-year training program given to health inspectors attempts to cover too many topics in too short a period of time. Insufficient attention is afforded to community participation activities and proper water system maintenance activities.

3.4.10 Vandalism

Cases of vandalism were observed only in Central Province, and it is likely that these were the result of villagers' frustrations with water systems which failed to provide the services promised. These were windmill or motor-driven pumped reticulation systems which were incorrectly designed or were built by contractors inexperienced in water supply construction. Based on the limited number (52) of water systems visited, the problem of vandalism does not appear to be as widespread as previously assumed. An alleged case of "payback" vandalism on the gravity transmission pipeline serving Djeck village, Western Highlands Province, turned out to be a pipe failure due to improper construction. (Note: most of this transmission pipeline is now exposed due to the erosion of soil cover over the pipe. One of the eight taps in this system is no longer used because the house it served was reportedly burned down by police last year to stop a battle with a neighboring tribe.) This breakage had been repaired and the system was found in good working order. Vandalism that does occur may be more often the result of frustration with a system that failed to provide the service it promised rather than the result of tribal payback or unprovoked, malicious mischief.

3.5 Project Financing

3.5.1 General*

The appraisal report for ADB-1 issued in September 1982 describes the financial magnitude of the program as perceived during the project's formative stages. At that time, it was thought that total funding, including both Government of Papua New Guinea and Asian Development Bank financing, would be the equivalent of US\$ 3,661,000. The principal components of costs for water and sanitation facilities as set forth in that document are as follows:

- Civil works, covering all direct costs for the construction of water and sanitation facilities in health centers, subcenters, aid posts, schools, and villages. This category excludes the cost of building such facilities which are funded under the other elements of the larger health services project. Overall, it was estimated that some 650 public facilities and an equal number of villages would be served over the five-year life of the project.
- Transportation, including both land and marine vehicles needed for construction of water and sanitation facilities.
- Increases in recurrent costs to operate and maintain the newly constructed facilities.
- Contingencies to provide a margin for unanticipated costs encountered during implementation and cost escalation due to expected

*See Appendix M for a detailed description of how the government's financial system works.

inflationary impacts. Both contingency items were applied in calculating cost projections for civil works and transportation, while only the price escalation factor was applied to the recurrent cost estimates.

The total budget and the basis for allocating funds to the provinces for water and sanitation activities was agreed upon when the memorandum of understanding was signed in June 1982 and confirmed in the loan agreement dated November 5, 1985. The project budget was to be defined in terms of the projected costs at 1982 prices without inclusion of either physical or price contingencies. Thus, a declining level of effort in real terms was built into the program, assuming that inflation would occur, which it did. Funds were to be allocated in equal annual budgets of Kina 60,000 per province. Analyses made earlier in 1982 by McGarry (9) which attempted to rationalize budget allocations according to needs and capabilities in each province were not incorporated. In fact, no recognition was made of the major differences between provinces in such matters as population, program experience, and current staffing levels and capabilities, nor to the degree of difficulty in the construction of water and sanitation facilities according to such factors as accessibility or terrain.

The agreed-upon terms for reimbursement by the Asian Development Bank of the costs of civil works to cover foreign exchange requirements were set at 55 percent even though the foreign exchange requirements for water and sanitation were projected at 67 percent. In addition, as agreed upon, the budgetary projections clearly excluded costs for contingencies (approximately 44 percent), while funds available for reimbursement remained at the higher level established for a much larger project budget. That set the stage for a situation resulting in a major shortfall in loan drawdown.

3.5.2 Reimbursable Costs

Asian Development Bank financing for the project, as initially perceived, was intended to cover the full amount of the estimated foreign exchange component and a portion of the local costs. For the total project, the bank figured that the equivalent of US\$ 10 million would be for direct foreign currency costs and another US\$ 2 million would be for local costs. Thus the total bank loan was projected at US\$ 12 million or approximately 57 percent of the total estimated project cost of US\$ 20.825 million. While the exact amount of projected bank funding for water and sanitation is not given, it can be derived from the appraisal report and subsequent official agreements as follows:

- Civil works funding in the amount equivalent to US\$ 1,708,000, including the full estimated foreign exchange cost, plus another 28 percent of civil works costs and contingencies.
- Transportation cost funding at 100 percent of the foreign exchange component or US\$ 288,000 including contingencies.
- Recurrent costs -- no bank funding. Although considered part of the project, recurrent costs are not eligible for bank funding.

Overall, Asian Development Bank funding for rural water supply and sanitation was estimated at the equivalent of US\$ 1,996,000. It should be noted that at the time of project preparation, the exchange rate was Kina 1.0 = US \$ 1.4 resulting in a Kina equivalent for project funding of K 1,415,600.

A summary of financial parameters developed during project formulation is presented in Table 5.

3.5.3 Financial Performance to Date

It is not surprising to find that the provinces have experienced difficulties in program implementation and in achieving effective and efficient utilization of funds. Utilization of funds alone is not a valid measure of good performance, as illustrated by the results in one province which used almost all of its funds during the first two years of the program through somewhat questionable expenditures.

Program expenditures have varied widely from province to province and year to year. A total of K 220,000 was expended in 1983, K 319,000 in 1984, falling back to K 294,000 in 1985. These figures compare with the K 360,000 budgeted annually and, had contingencies been included in the project budget, an average annual expenditure of K 519,000. Reimbursements were K 187,117 in 1983, rising to K 278,677 in 1984 and then at K 277,620 in 1985.

The government and the Asian Development Bank agreed, effective September 1984, to increase the proportion of reimbursable expenditures for civil works to 62 percent for foreign exchange and 32 percent for local expenditures for civil works instead of 55 percent and 28 percent, raising the total from 83 percent to 94 percent. This was done to compensate for the devaluation of the Kina against the US dollar (in early 1986 the Kina was approximately at par with the US dollar). Since the loan dollars now buy more Kina, the projected shortfall in loan drawdown is further exacerbated, even after taking account of the increase in the proportion of reimbursable expenditures.

Financial performance data by province are presented in Table 6, together with loan disbursements and figures showing approximate financial costs (e.g., interest and commitment charges). Although commitment and interest charges are covered separately in the Papua New Guinea budget, it is appropriate to consider them as an element of program cost.

3.5.4 Financial Projections

Based on the experiences of the first three years, annual program expenditures averaging K 320,000 per year during 1986 and 1987 seem reasonable, possibly optimistic. Under these assumptions, loan drawdown for rural water and sanitation would reach K 1,345,000 by the currently scheduled completion date for the project, leaving K 651,000 undisbursed.

A recap of these projections is presented in Table 7, which illustrates two potential options, one involving continuation of the project for two years and the other for three additional years with a gradually declining level of Asian Development Bank participation. This latter option would permit the government

Table 5

Financing Parameters at Project Formulation

Rural Water and Sanitation Program
Department of Health, Papua New Guinea

| Program Element | Program Costs, US\$ 000, 1982 Prices | | | | | US\$ 000 Basis of Loan Disbursements | | | | |
|-----------------|--------------------------------------|-------------|-----------|---------------|-------|---|-------------|-----------|---------------|-------|
| | Foreign Exchange | Local Costs | Sub-Total | Contingencies | Total | Foreign Exchange | Local Costs | Sub-Total | Unallo- cated | Total |
| Civil works | 927 | 459 | 1,386 | 612 | 1,998 | 927 | 388 | 1,315 | 393 | 1,708 |
| Transportation | 222 | 405 | 627 | 277 | 904 | 222 | - | 222 | 66 | 288 |
| Recurrent | - | 582 | 582 | 177 | 759 | - | - | - | - | - |
| Totals | 1,149 | 1,446 | 2,595 | 1,066 | 3,661 | 1,149 | 388 | 1,537 | 459 | 1,996 |

Notes:

- (1) Contingencies are approximately 14 percent of civil works and transportation base costs for unpredictable physical conditions and 30 percent of all costs for price escalation.
- (2) The US\$/Kina exchange rate in 1982 was US\$1.41/K1.00.
- (3) Source of cost data is Appraisal of the Rural Health Services Project in Papua New Guinea, September 1982.
- (4) Source of loan disbursement data is the Loan Agreement, dated 5 November 1982.

to increase its participation gradually until the program is fully funded through local sources in 1991. Of course, these options presuppose both the desire of the government to continue the program, ultimately without external financial assistance, and the willingness of the Asian Development Bank to extend the period of disbursement. If a loan extension is not to be agreed upon, it would seem appropriate to negotiate cancellation of that portion of the loan which is projected to remain unused.

Table 6

**Program Expenditures and Loan Disbursements
Rural Water and Sanitation Program
Department of Health, Papua New Guinea**

| <u>Province</u> | <u>Expenditures, K 000</u> | | |
|----------------------------------|----------------------------|-------------|-------------|
| | <u>1983</u> | <u>1984</u> | <u>1985</u> |
| Central | 59 | 60 | 39 |
| Gulf | 28 | 49 | 55 |
| Western Highlands | 15 | 46 | 48 |
| Madang | 45 | 53 | 49 |
| East Sepik | 58 | 58 | 61 |
| West Sepik | 15 | 54 | 42 |
| Totals | 220 | 319 | 294 |
| Commitment Charges (estimate) | 14 | 12 | 10 |
| Interest (estimate) | 6 | 33 | 67 |
| Loan Reimbursements | 187 | 279 | 278 |

Notes:

- (1) 1985 figures are those prepared for submission to ADB, but not yet approved.
 - (2) By 1988, interest is projected to be K 148,000; if the full amount available is drawn, interest would rise to K 220,000.
-

Table 7

**Projected Program Expenditures and Reimbursements under
Alternate Funding Assistance Terms
Rural Water Supply and Sanitation Program
Department of Health, Papua New Guinea**

| Funding Assistance Terms | Projected Expenditures/Reimbursements Kina 000s | | | | |
|--|--|---------|---------|---------|---------|
| | 1986 | 1987 | 1988 | 1989 | 1990 |
| As presently defined | 310/291 | 330/310 | 340/319 | 353/332 | 350/0 |
| Modified to provide gradual phase-out of external assistance | 310/291 | 330/310 | 340/276 | 353/225 | 350/150 |

Notes:

- (1) Projected reimbursements for 1988-1990 are based on full use of available funds remaining after 1987, the scheduled date for project termination.
- (2) Continuation of the present budget allocation of K 60,000 per province per year is assumed.

3.5.5 Effectiveness in Fund Utilization

In some instances, fund utilization has obviously been poor; in others the situation is not clear but it may be assumed to be poor; and in still other cases one finds it difficult to make an assessment due to insufficient information. Overall however, the performance has not been up to expectations. Provinces have been generally unable to fully expend their allocations and have often failed to make best use of those funds which have been expended.

There are a number of factors contributing to this situation, including:

- As previously noted, the funding schedule unrealistically assumed that all six provinces had the capability to make effective use of the full funding level from the very first year. There was perhaps, insufficient appreciation of the need for institution building, developing baseline data for subsequent investment decisions, and mobilizing village resources to assure that sufficient local commitment existed to warrant the expenditure of project funds.
- Other contributing factors include the lack of managerial training/skills of the officers in charge, a general inability to deal with the financial systems, and a lack of planning resources/

information. Also, the water and sanitation function is positioned on the periphery of primary health care activities. In some provinces this has led to inadequate organizational status and lack of a program "advocate" at a sufficiently high organizational level.

After three years of experience with the program, however, the provinces are beginning to develop a foundation for better performance in the future. Surveys are being undertaken to develop needed baseline data, standard requirements for village interest and commitment are being enforced, and some attempt is being made to provide an objective basis for project selection.

3.5.6 Opportunities for Improving Fund Utilization

Improving fund utilization involves many factors outside of the "financial scope," as well as financially oriented measures. The ability to predict the costs of projects, to compare costs with benefits and then to measure actual costs, however, is the foundation for improved fund utilization. The officers in charge and the public health inspectors have developed a basic understanding of data requirements for measuring the potential benefits of candidate projects. To a certain extent this data exists or is in the process of development.

The missing links in the cost predicting and measurement formula are the financial systems and the project costing, scheduling, and control systems (see Appendix M). The government financial systems are not designed to accommodate a project costing and management system and must be assumed to be unchangeable. If a project costing and management system is to be implemented for rural water and sanitation, it must be developed, implemented and operated through the resources available in the project implementation unit and the operating and supporting units at the provincial level.

Conceptually, a system that could feasibly be developed by the staff of the project implementation unit and implemented on a province by province basis in the field, would be structured along the following lines:

- A simplified project management system would be developed including work planning and scheduling checksheets and task rosters/lists.
- Standard project "modules" would be prepared covering the commonly employed technologies such as dug wells, bore/auger wells, rainwater catchments, and reticulation systems. Each module would consist of a standard bill of materials with costs, typical costs of staff time and labor, travel and subsistence payments, transportation and equipment rental as appropriate, and an overhead item covering the properly allocable expenses incurred in project development, design, and other preparatory activities.
- A figure would also be developed to cover the total resources available to the officer in charge for the development of water supply and sanitation systems. This would presumably be different

from the total budget allocation, since one or more projects may overlap the budget year's starting/ending dates.

With this system in place, it would be possible to evaluate the merits of prospective projects on a benefit/cost basis, to gauge the capacity of the resources of the officer in charge for accomplishing projects, and to establish priorities on an objective basis. Once established, the only "accounting" required of the officer in charge would be to record cost variations from the standard costs on an "exception" basis. This would eliminate the need for the meticulous and time-consuming recording of relatively meaningless cost data being done at present by some officers in charge. Interfacing factors would be available which would allow the officer in charge to easily transform his planned and costed work program for the coming year into his line item budget request together with cash flow forecasts for the year. Finally, the rate of expenditure of funds then would become an indicator of actual performance against planned accomplishments. Officer in charge reports would merely state progress in terms of completed projects and the status of budget commitments by line item.

Resources for developing this system should be made available by allocating a portion of the time of the health management advisor and the sanitary engineer. As team, they would design the project management system and cost modules and work with the provincial health officials in providing the necessary training and assistance to implement the system in each province. Information officers to be appointed in each province should also be trained in the system, so that they can provide support in system management to the officers in charge.

In a more general approach to improving fund utilization, general training and orientation in the financial systems of Papua New Guinea (from the viewpoint of the operating official) should be provided to officers in charge. Establishing a training outline and holding training sessions should be the joint responsibilities of the project accountant in the Project Implementation Unit and the administrative officers within each health division.

One final thought on improving fund utilization relates to oversight of the quarterly allocation process. Apparently oversight activities are already being planned. They are strongly supported. Such back-up support will assure that delays and other problems are not encountered as a result of errors or omissions in the funding process, at least to the extent that knowledge of the situation and what to do about it can achieve such results.

3.6 Staff Training

Health inspectors are trained at the College of Allied Sciences in Madang. A review of the three-year training curriculum for health inspectors reads almost like a compendium of topics in the fields of public health, sanitation, and sanitary engineering. Trying to provide instruction in this full range of topics to prepare graduate health inspectors is admirable and understandable, especially when viewed in terms of the country's need. However, in comparing the objectives of this training course with those for the training of sanitarians and sanitary or environmental engineers in the United States or Australia, each of which requires a minimum of four years to produce a

graduate (without field experience), it is obvious that the length of time (three years) allocated is insufficient to develop proficiency to do independent work in the 20 areas covered in the curriculum.

In addition to classroom work, the students receive field experience during the second year by being assigned to various health facilities in neighboring provinces to practice what they have been taught. Not all of the subjects included in the curriculum can be covered in depth because of time and staff limitations.

A few of the artisans working in the program have received training at the Oliguti Training Centre run by the Department of Works in Eastern Highlands Province. This is a nine-month basic rural water supply course placing emphasis on practical on-the-job training covering ten major topics (see Appendix N).

Several workshops sponsored by UNICEF and WHO have been conducted by the Department of Health during the past three years. Those workshops relating to the water and sanitation program are shown in Table 8 below.

Table 8

Water and Sanitation Workshops Held and Planned

| <u>Topic of Workshop</u> | <u>Dates</u> | <u>Location</u> | <u>Sponsor</u> | <u>Number of Participants</u> |
|---|--------------------------|-------------------|----------------|-------------------------------|
| <u>Workshops Held</u> | | | | |
| 1. Water and Sanitation | October 7 to 11, 1983 | Rabaul | UNICEF | 16 |
| 2. Water and Sanitation | April 9 to 13, 1984 | Madang | UNICEF | 20 |
| 3. Water and Sanitation | August 6 to 10, 1984 | Mt. Hagen | UNICEF | 11 |
| 4. Ferro-cement Tanks | April 15 to 26, 1985 | Samaraj Island | UNICEF | 31 |
| 5. Planning and Design of Water/Sanitation Programs | July 15 to 19, 1985 | Lae | WHO | 24 |
| 6. Ferro-cement Tanks | August 5 to 16, 1985 | Rabaul | WHO | 25 |

Table 8 (cont'd.)

| <u>Topic of Workshop</u> | <u>Dates</u> | <u>Location</u> | <u>Sponsor</u> | <u>Number of Participants</u> |
|---|-------------------------|-----------------|----------------|-------------------------------|
| <u>Workshops Held</u> | | | | |
| 7. Planning and Design of Water/Sanitation Programs | September 9 to 13, 1985 | Arono Island | WHO | 20 |
| 8. Water Quality Monitoring and Surveillance | October 14 to 18, 1985 | Lae | WHO | 17 |
| 9. Water Quality Monitoring and Surveillance | October 21 to 25, 1985 | Madang | WHO | 18 |
| <u>Workshops Planned</u> | | | | |
| 1. Ferro-cement Tanks | April 1986 (1 week) | - | WHO | - |
| 2. Management | July 1986 (1 week) | - | WHO | - |
| 3. Planning and Design of Water/Sanitation Programs | September 1986 (1 week) | - | WHO | - |
| 4. Community Participation | November 1986 (1 week) | - | WHO | - |

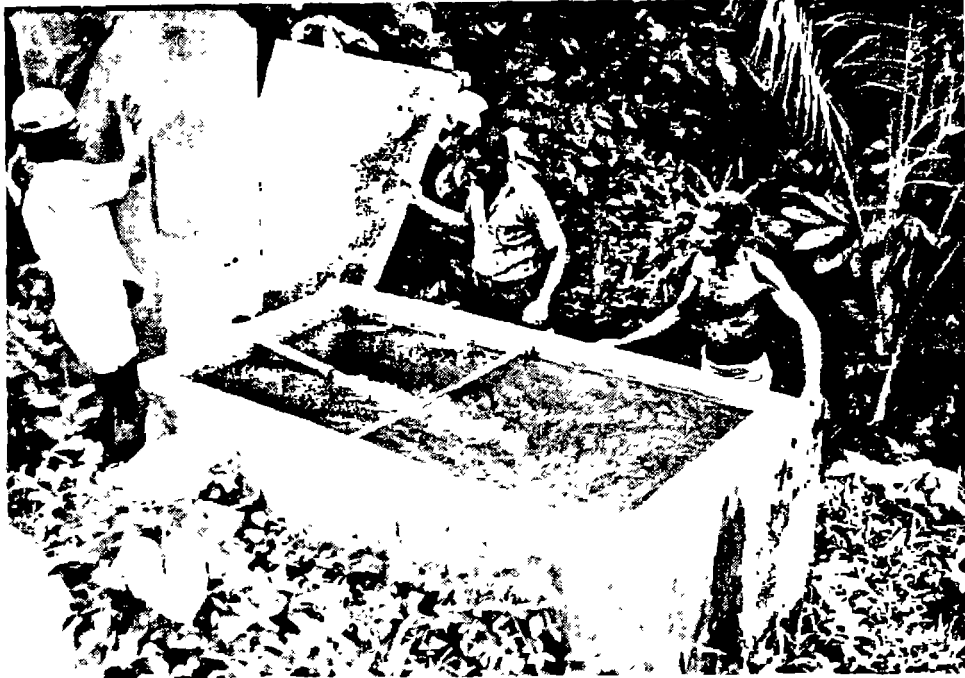

Photo 1. Spring-fed collection tank.



Photo 2. Seepage dam.



Photo 3. Beach front latrines.

Rainwater Storage Tanks

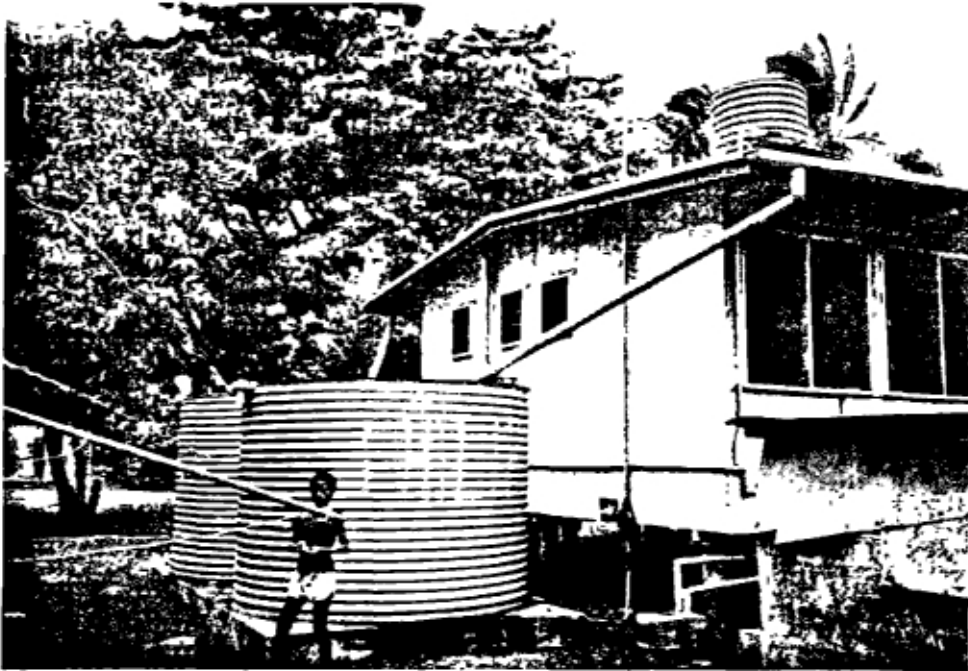

Photo 4. Galvanized steel ground-level and roof tanks.



Photo 5. Fiberglass tanks and photo-voltaic panels.

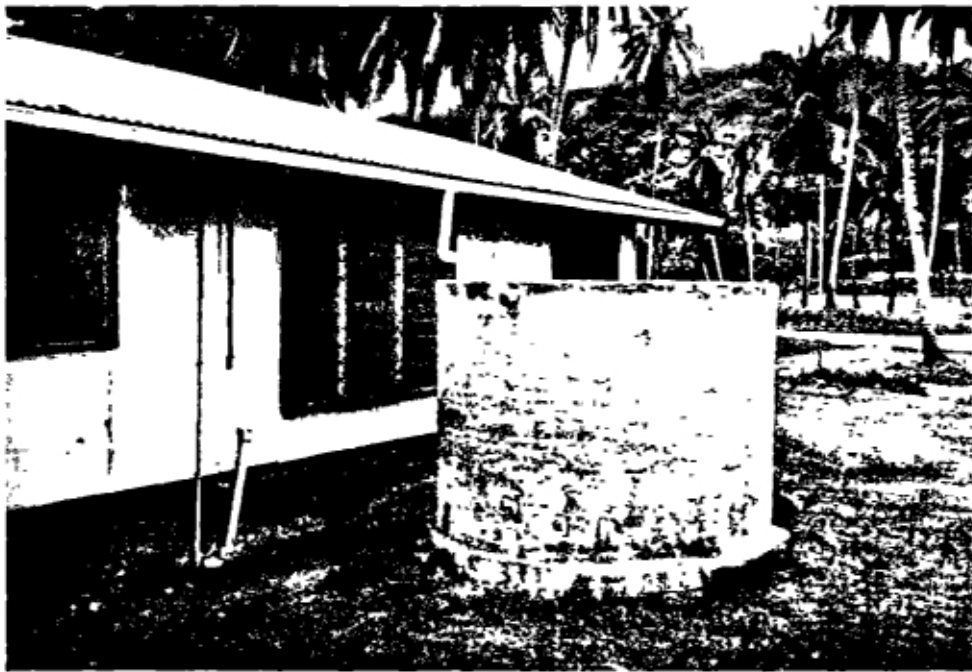

Photo 6. Galvanized tank rehabilitated with ferro-cement.



Photo 7. Production of well liners.



Photo 8. Dug well and offset handpump.

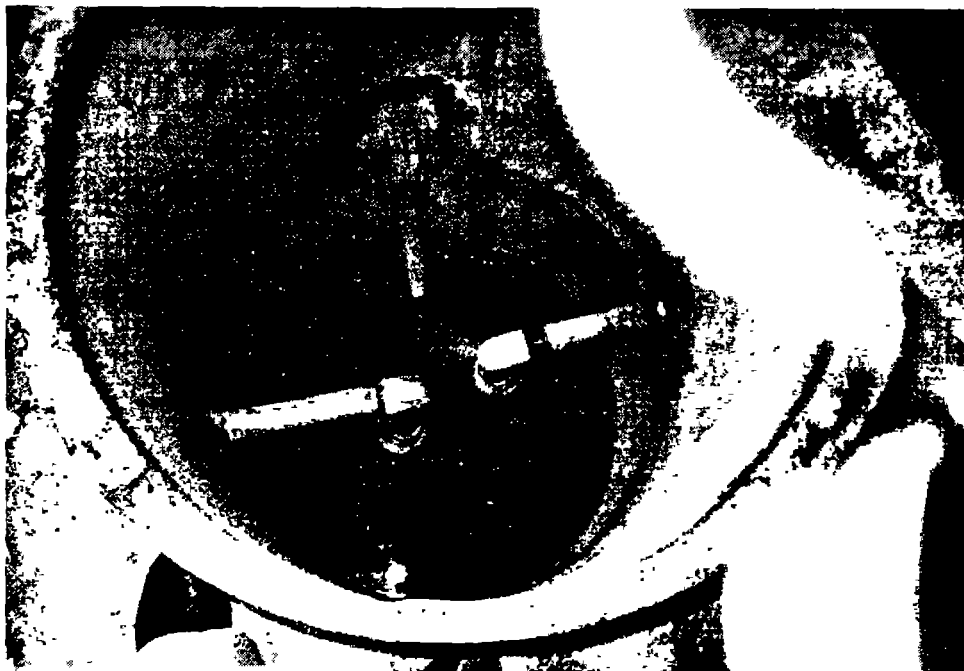

Photo 9. Interior of well liner showing drop pipes for offset handpumps.

Photos 10 and 11. Production of Latrine Slabs

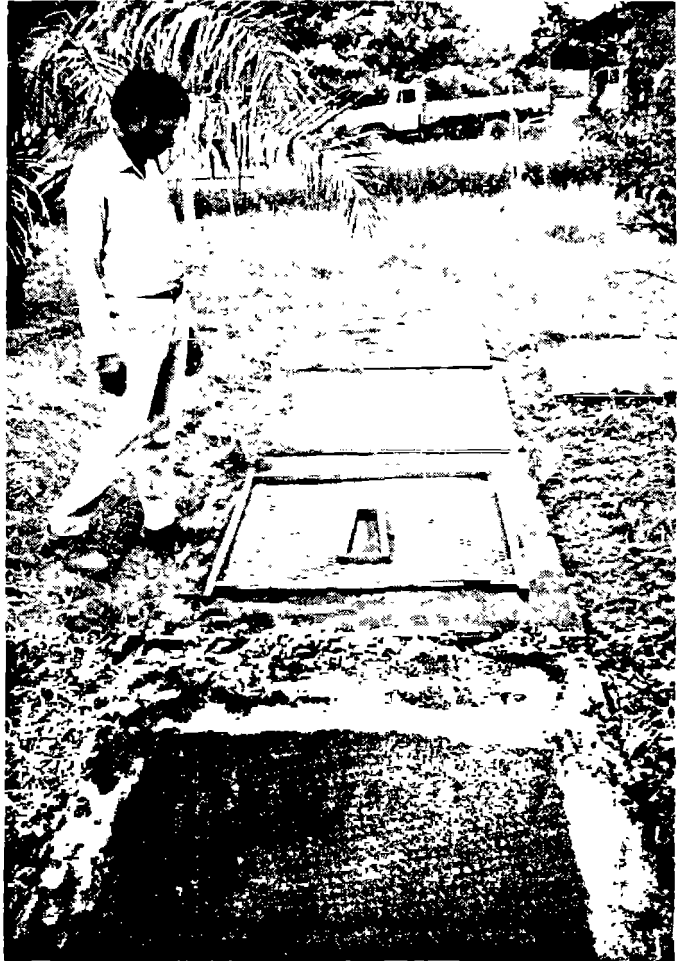

Photo 10.



Photo 11.

Photos 12-15. Types of excreta disposal installations.

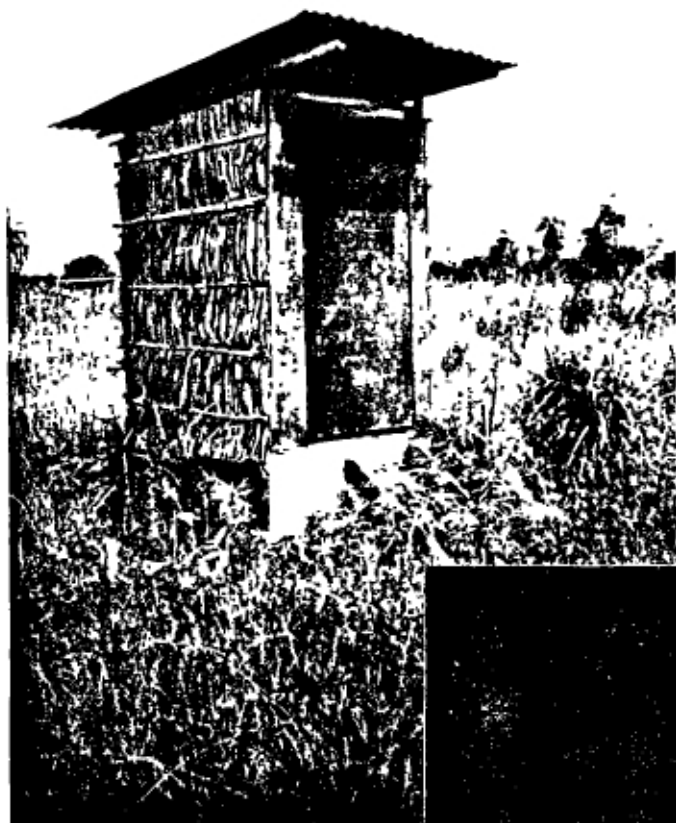

Photo 12.



Photo 13.



Photo 14.



Photo 15.

Photos 16-18. Women fetching water.



Photo 16.



Photo 17.



Photo 18.



Photo 19. Fuji handpump.



Photo 20. Onga Handpump.



Photo 21. PNG Handpump.



Photo 22. Semi-rotary handpump.



Photo 23. Windmill.

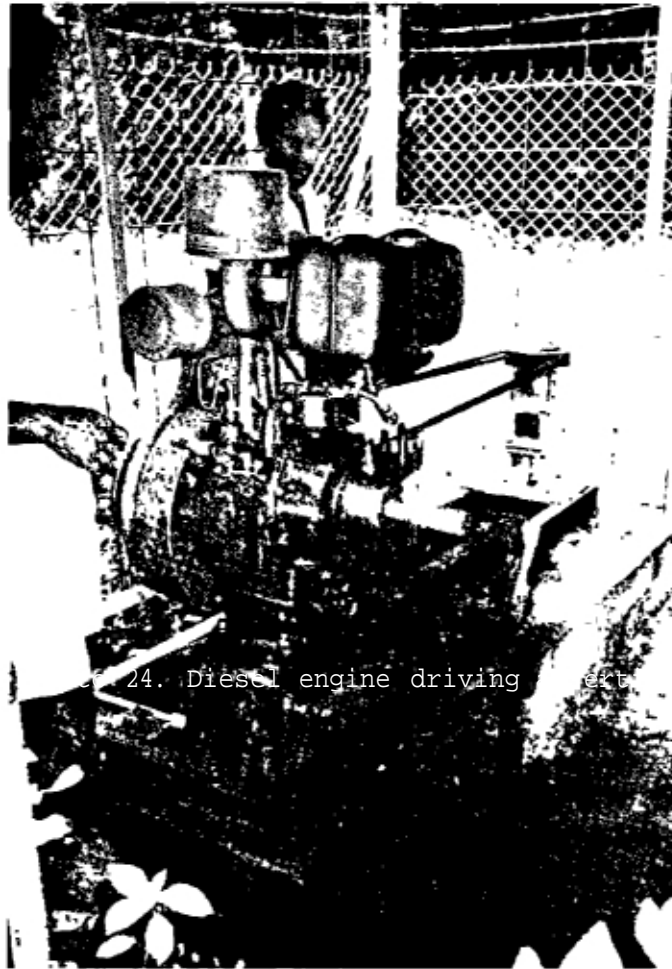

24. Diesel engine driving a vertical turbine pump.

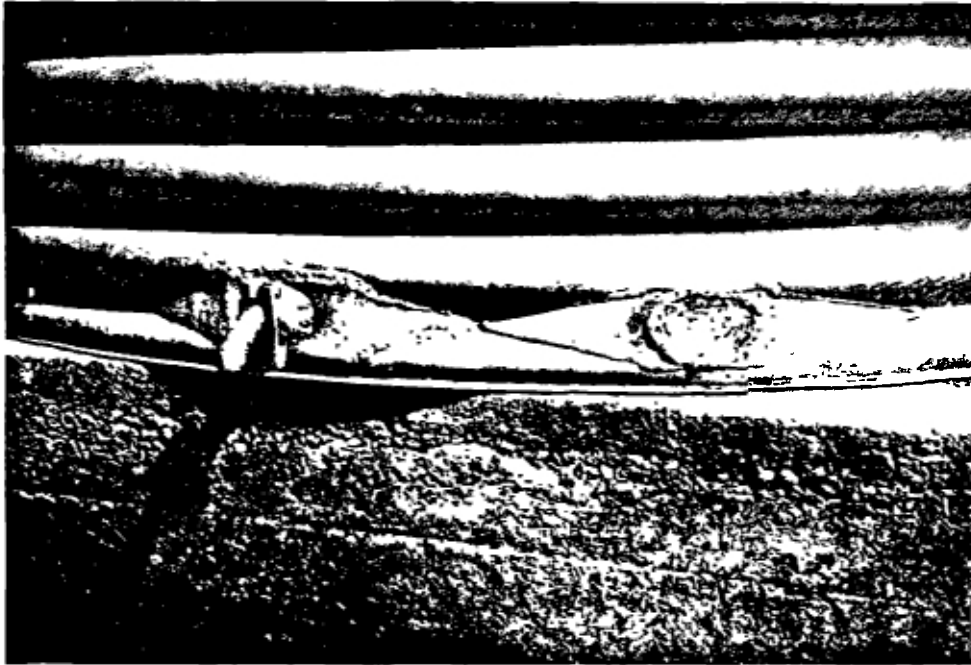

Photo 25. Repaired rainwater tank faucet.

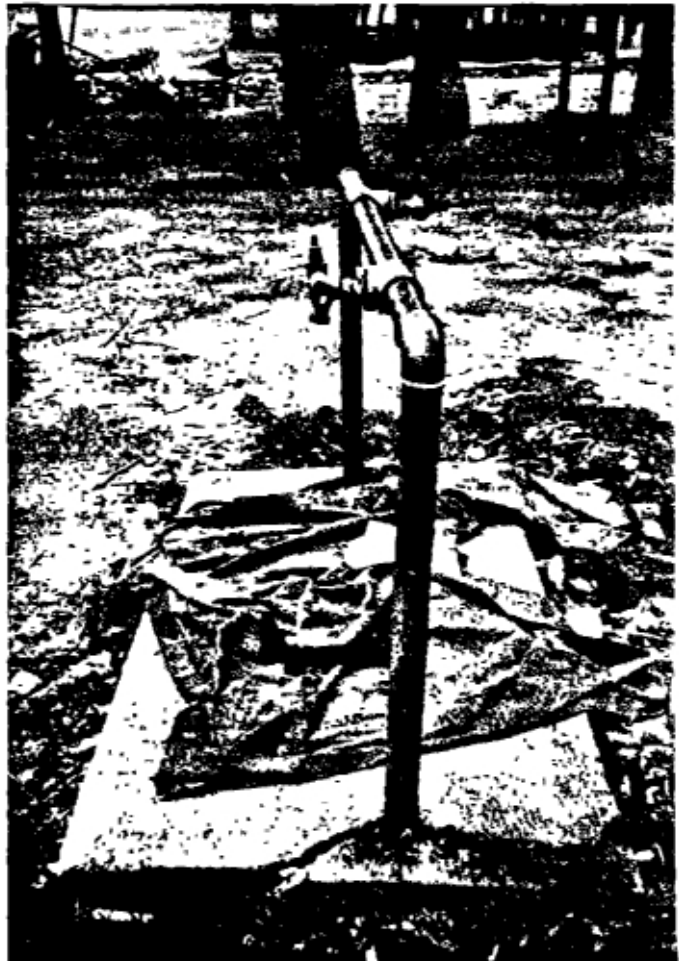

Photo 26. Vandalized public taps.



27. Public tap and shower installation.



Photo 28. Double public tap.

Chapter 4

RECOMMENDATIONS

4.1 Project Resources

1. The additional human and material resources, shown in the ADB-1 appraisal report as necessary for project implementation, should be assigned by the respective provinces to the water and sanitation program on a full-time basis.
2. The Department of Health should consider asking the Asian Development Bank for an extension of two to three years. This will allow sufficient time to utilize all of the budgeted funds and to further strengthen the water and sanitation program by providing additional training to the staff. In contemplating an extension, the department should determine if it would be in its best interest to plan a year-by-year phase-down of Asian Development Bank funding while simultaneously increasing the government's share to cover the full cost of the program in the six provinces by the end of the extension period.

4.2 Project Management

1. The Department of Health should consider expanding the Project Implementation Unit by appointing the assistant secretary for environmental health or his designee to it. As the person responsible for the water and sanitation component, he will participate in all Project Implementation Unit meetings and will take the lead in discussions and decisions directly related to this activity. In his official capacity as assistant secretary, he will be able to channel all project communications through his office thus assuring consistency and compatibility between ADB-1 project and regular department program activities.
2. The Department of Health should increase the staff of the environmental health section. At a minimum, a deputy and another senior health inspector should be hired to provide the manpower needed.
3. At the provincial level, the officers in charge should be formally designated as heads of the water and sanitation component and their position in the organization raised to a level equal to that of other heads of major project activities. In their upgraded position, the officers in charge would report directly to the provincial ADB-1 project manager.
4. The Department of Health should encourage provincial health offices to explore the possibility of obtaining the services of technically qualified volunteers to supplement their staffs especially at the district health inspector level. Where official vacant positions do not exist, the provinces should consider requesting and utilizing Peace Corps volunteers, who do not require government funding or support, unlike other volunteer agencies who do.

5. The term of service of the sanitation specialist/trainer recommended in the ADB-2 appraisal report should be increased from nine man-months to two years and the scope of work limited to the operation and maintenance of water supply and sanitation systems and the related training of health inspectors and village caretakers. Working with appropriate department and provincial staff, he should establish a maintenance program and a maintenance management system.
6. The department should explore the possibility of obtaining the services of a community development and promotion specialist now working in the country on either a full-time or part-time basis. The consultant would be responsible for planning and implementing a community development and promotion activity and the training of health inspectors and construction team leaders in these topics.
7. All water supply and sanitation consultants should coordinate their activities through the assistant secretary for environmental health in his role as member of the project implementation unit as well as in his official capacity.
8. Both Department of Health and Project Implementation Unit staff should develop travel budgets which would allow more frequent visits to the provinces to develop close personal relationships with their provincial colleagues and to obtain a comprehensive first-hand exposure to and knowledge of field activities.
9. The newsletter, "The Wetline", should be established as an official publication of the department's environmental health section and should be published on a predetermined periodic basis. Continued emphasis should be placed on establishing an open dialogue between Port Moresby and the provinces by encouraging contributions from the field.
10. The Department of Health and Project Implementation Unit staff should work with provincial health staffs to develop standard reporting formats designed to elicit the additional information needed to properly monitor project activities at both the provincial and national levels.
11. To alleviate some of the logistics problems, the Department of Health should review village selection criteria and decide if priority should be given to villages with the best access. This policy change would allow time for staff to become more experienced and more able to tackle increasingly difficult jobs as work progresses.
12. Based on progress made to date and on available resources, the Project Implementation Unit should prepare a revised implementation plan for the remaining life of the project. This plan should be accompanied by an end-of-project status report describing the extent to which project outputs will have been achieved by the end of 1987. These two documents should provide the information needed by the department to decide whether to request an extension of the project or a cancellation of that portion of the loan which will remain unused.

4.3 Project Activities

1. The Department of Health should obtain copies of all existing village water supply surveys compiled by the Department of Lands and Surveys in the late 1960s and early 1970s. Although dated, the information provided should suffice for initial program planning purposes. Provinces already involved in conducting new surveys, based on the comprehensive design prepared by the World Health Organization staff, should complete their planned program. The remaining provinces should update the old survey data utilizing the first-hand knowledge of its field staff and prepare their initial program plans.
2. The Project Implementation Unit, in collaboration with the health services management and in-service training consultants and provincial officers in charge, should plan and conduct a program planning and budgeting workshop for officers in charge of the water and sanitation program. The workshop should be designed to have each participant prepare an official water and sanitation program and budget for the succeeding year using data compiled by the participants from their respective province files.
3. The Department of Health should seek information and assistance from other governmental and non-governmental agencies engaged in community development and promotion programs. Based on its findings, the department should determine what resources it will need to obtain to plan and implement a community development and promotion activity as an integral part of the water and sanitation program.
4. The Project Implementation Unit and provincial health staffs should gather information on women's groups and their activities in each of the provinces. Recognizing women's predominant role as the purveyors and users of water, officers in charge, assisted by relevant provincial health personnel, should make a determined effort to involve women's groups in the water and sanitation program.
5. The Department of Health should encourage provincial officers in charge to utilize the professional services of the local government engineers section in the design and construction of the more difficult gravity reticulation systems. The Department of Health should also develop a close working relationship with the local government engineers section and jointly develop an on-the-job training workshop to provide field training for officers in charge in reticulation system design and construction.
6. Recognizing the villagers' lack of interest in and enthusiasm for concrete slab latrines, the Department of Health should explore the desirability and feasibility of installing latrines with bench seats constructed of local materials. Also, instead of concentrating solely on latrine installation, the Department of Health should consider including such personal hygiene topics as bathing, clothes laundering, hand washing, and the use of soap in its health education program.
7. The Department of Health should prepare a water system acceptance document to be delivered and signed by the village water committee

members and the officer in charge during the ceremony to officially turn the completed water system over to the village.

8. The department should also prepare an operation and maintenance manual describing the duties and responsibilities of the village water committee and caretaker as well as those of the provincial health office. This document should be presented and explained to the villagers during the initial contacts with the village.
9. The provincial divisions of health should require villages receiving improved water systems to contribute a certain amount of cash toward purchasing materials needed to construct the system. Each village should initiate a water fund with each household contributing a small amount (for example, 50 toea a month). This fund should be established before construction is started.
10. Community development workshops should be held with the village before the water systems are constructed. The workshops would address the following topics:
 - managing the water system
 - the water committee
 - water funds
 - maintenance
 - selection of a caretaker
 - procurement of spare parts and tools
 - reporting major problems
 - protection of the water systems
 - proper usage of water
 - the specific maintenance tasks that the village is responsible for
 - health benefits of good water
 - sanitation and personal hygiene practices
 - training for caretakers (during construction)

There are two ways to accomplish these workshops. The officers in charge could be trained to carry them out or the Government of Papua New Guinea could employ the services of non-governmental agencies such as the South Pacific Appropriate Technology Foundation to plan and carry out these workshops. Because of the heavy workload of the officers in charge, the latter approach is preferred. The Government of Papua New Guinea should seek volunteers or funding for this effort from governmental or non-governmental agencies.

11. Funds should be budgeted annually in the provinces for the maintenance of water systems in rural areas. This should be done even if the construction of some new water systems has to be deferred.
12. The Department of Health should develop a maintenance management system to gather information on the maintenance status of water supply systems. Information on the number of maintenance requests, actions taken, and labor, materials, and funds expended on maintenance by the province should be reported. The system should involve construction team leaders, district health inspectors, officers in charge, and Department of Health central staff.

An annual maintenance report should be submitted to the Department of Health so that government officials and others will know what resources are being expended on maintenance and how rural water systems are being maintained.

13. A national workshop should be held to introduce the concept of a maintenance management system and, with assistance from the Department of Health, to finalize the type of data needed for the rural water system program and method of implementation. This workshop should be conducted by a professional experienced in maintenance programs.

4.4 Project Financing

1. The project should take into consideration provincial populations and health office capabilities for allocating funds to provinces instead of the flat rate of Kina 60,000 per year per province.
2. The Department of Health should create a grant fund by retaining about 15 percent of project funding for awarding to provinces with demonstrated needs and capabilities for effective fund utilization. The department should create a committee to evaluate applications and make awards during the second or third quarter of each year.
3. The Department of Health should develop financial systems to account for total government investment in the sector by incorporating all rural water and sanitation activities in the government budget for the water and sanitation sector.
4. The Department of Health should develop and implement a simplified costing system employing standard cost modules which will permit individual project costs to be estimated during the planning process. This will make it possible for provincial staff to establish project priorities and to standardize the planning and budgeting process. Modular cost estimates should be developed for each of the three main types of water systems. For example, the "Wetline" (4) estimates that it costs Kina 900 to install a modified PNG handpump. Similar modular cost estimates should be developed for rainwater catchments and reticulation systems.
5. The Department of Health should appoint the Project Implementation Unit accountant to coordinate and work with the administrative officers in each provincial division of health to develop and implement a practical training syllabus for provincial health inspectors and officers in charge designed to improve their understanding of and ability to deal with the government's financial systems.
6. The Department of Health should implement, as currently planned, the systematic and detailed review of quarterly allocations made to provinces for rural water supply and sanitation and should provide advice and assistance to correct errors and to resolve problems as they occur.

4.5 Staff Training

1. The sanitation specialist/trainer referred to in Section 4.2, paragraph 5, in collaboration with the Project Implementation Unit and provincial officers in charge, should design and manage the following training activities:
 - a practical operation and maintenance course for officers in charge and district health inspectors.
 - a village caretaker training syllabus in first level operation and maintenance. The training course could be designed to train village caretakers themselves or to train health inspectors and construction team leaders as trainers. The actual training could be conducted through a contract with a non-governmental organization such as the South Pacific Appropriate Technology Foundation (SPATF).
2. As noted in Section 4.3, paragraph 5, the Department of Health should collaborate with the local government engineers section in Madang to develop a practical workshop for officers in charge and selected district health inspectors in the design and construction of gravity reticulation systems. The duration of this course should be from four to six weeks long or as agreed upon between the department and the local government engineers section.
3. As noted in Section 4.2, paragraph 6, the services of a community development and promotion specialist should be obtained to develop and conduct a training workshop for officers in charge, district health inspectors, and construction team leaders in community development and promotion techniques. This training activity might be designed as a joint venture with another agency involved in community development and promotion.
4. As noted in Section 4.4, paragraph 5, the Project Implementation Unit accountant, working with provincial administrative officers, should develop a practical syllabus and train provincial health inspectors and officers in charge in understanding and utilizing the government's financial systems in their programs.
5. An office clerk/bookkeeper should be hired and trained in each province to handle the purchasing and warehousing of materials and cost accounting for the project.
6. The Department of Health should contact the staff of the Oliguti Training Centre mentioned in Section 3.6 to see if it would be possible and advantageous to jointly develop short training courses on selected subjects covered in the syllabus which are of specific interest to the department.
7. As noted in Section 4.3, paragraph 2, the Project Implementation Unit should arrange to train officers in charge in program planning and budgeting.

8. The assistant secretary for environmental health, in collaboration with the health services management and in-service training consultants, should develop a workshop to train officers in charge in management and supervision theory and practice.

LOGICAL FRAMEWORK FOR ADB--1 WATER SUPPLY AND SANITATION COMPONENT

| | OBJECTIVELY VERIFIABLE ACCOMPLISHMENT INDICATORS | MEANS OF VERIFICATION | ASSUMPTIONS & LINKAGES |
|--|---|---|---|
| <u>GOALS</u> IMPROVE THE HEALTH STATUS OF THE POPULATION OF SELECTED REGIONS OF PNG. | REDUCTION IN MORBIDITY & MORTALITY DUE TO WATER, HYGIENE, AND SANITATION--RELATED DISEASES. | OFFICIAL HEALTH STATISTICS, IMPACT EVALUATION, STATISTICAL SAMPLING AND ANALYSIS OF DATA. | THAT THE USE OF MORE AND BETTER QUALITY WATER AND SAFE EXCRETA DISPOSAL PRACTICES WILL RESULT IN IMPROVED HEALTH. |
| <u>PURPOSE</u> GET VILLAGERS TO USE ADEQUATE QUANTITIES OF BETTER QUALITY WATER AND USE SAFE EXCRETA DISPOSAL METHODS. | MEASUREMENT OF INCREASED WATER CONSUMPTION BY VILLAGERS. CHANGE TO SAFE EXCRETA DISPOSAL PRACTICES. | FIELD STUDY AND DIRECT OBSERVATION AND QUANTITY MEASUREMENT. WATER SAMPLING AND ANALYSIS. FIELD STUDY. | THAT THE WATER SUPPLY AND SANITATION SYSTEMS WILL FUNCTION PROPERLY AND VILLAGERS WILL USE THEM. |
| <u>OUTPUTS</u> WATER SUPPLY SYSTEMS {650 + 650 = 1300} LATRINES {650 + 650 = 1300} TRAINING SESSIONS, WORKSHOPS, ETC. WATER COMMITTEES CARETAKERS | NUMBER INSTALLED OR REHABILITATED. NUMBER BUILT OR NUMBER OF SLABS ISSUED. NUMBER OF PARTICIPANTS COMPLETING ACTIVITY. NUMBER FORMED AND OPERATING. NUMBER TRAINED AND WORKING. | OFFICIAL REPORTS AND FIELD SURVEYS. ACTIVITY REPORTS AND FIELD SURVEYS. | THAT NECESSARY INSTITUTIONAL, HUMAN, MATERIAL, AND FINANCIAL RESOURCES ARE AVAILABLE AND ARE ORGANIZED AND UTILIZED IN AN EFFECTIVE MANNER. |
| <u>INPUTS</u> FUNDS--\$ _____, K _____ INSTITUTIONS--DOH AND 6 PROV. HEALTH DIV. STAFF TECHNICAL ASSISTANCE---CONSULTANTS COMMODITIES/EQUIPMENT PROJECT FUNDED VILLAGE CONTRIBUTIONS LABOR DONATED BY VILLAGES | FUNDS EXPENDED PERSONNEL ASSIGNED. consultants recruited AND WORKING. ACQUISITION AND USE OF ITEMS. NUMBER OF MAN/DAYS OF WORK PERFORMED | PERIODIC PROGRESS AND FINANCIAL REPORTS. ANNUAL REPORTS TO ADB. physical inventories. PROJECT CONSTRUCTION REPORTS AND RECORDS. | THAT THE PROJECT/LOAN AGREEMENT IS APPROVED AND SIGNED. |

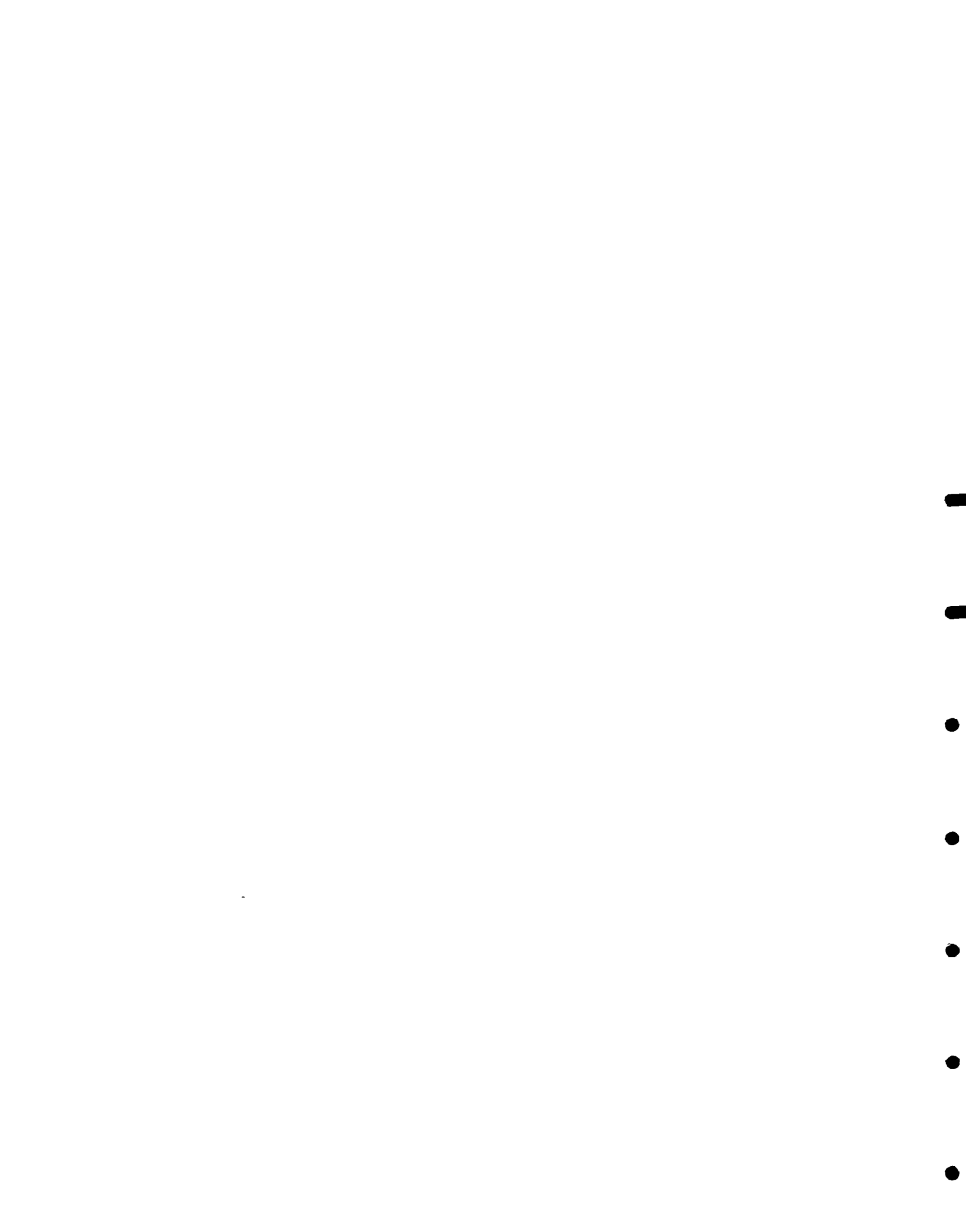

REFERENCES

1. Asian Development Bank. Appraisal of a Second Rural Health Services Project in Papua New Guinea. October 1985.
2. Asian Development Bank. Appraisal of the Rural Health Services Project in Papua New Guinea. September 1982.
3. Asian Development Bank. Loan Agreement (ordinary operations) (Rural Health Services Project) between the independent state of Papua New Guinea and Asian Development Bank. Dated 5 November 1982. (Loan Number 586 PNG)
4. Asian Development Bank. The Wetline, A Rural Water Supply Newsletter for Papua New Guinea. Issued by the Department of Health, Boroko. 1985.
5. Helminiak, T. Consultant's Report for Asian Development Bank. Papua New Guinea: Rural Health Services Project. April 1982.
6. Jenkins, Carol. The Amele and Bundi Water Projects in Madang Province. Papua New Guinea Institute of Medical Research, Goroka. July 19-20, 1984.
7. Kinnell, G.H. A Case Study on Water Supply Systems in Boera Village and Evaluation and Selection of Solar Photovoltaic Systems in Central Province, Papua New Guinea. UNDP and WHO. Regional Office for the Western Pacific Region, WHO. Manila, Philippines. August 1985.
8. Laver, Sue. Handbook for the Protection of Village Water Supplies in Zimbabwe. Department of Community Medicine, University of Zimbabwe. (No date.)
9. McGarry, Michael. Papua New Guinea: Rural Health Services Project, Water Supply and Sanitation. Social Infrastructure Division, Asian Development Bank. April 1982.
10. Nakau, C., and D. Rowsome. The Evaluation of a Handpump. WEDC 12th Conference: Water and Sanitation at Mid-Decade: Calcutta 1986.
11. Papua New Guinea. Department of Health Semi-Annual Reports. Rural Health Services Project. 1983/84/85.
12. Papua New Guinea. Medium Term Development Strategy (MTDS). Interim Report: A Review of the Health Sector. October 1984.
13. Papua New Guinea. Memorandum of Understanding. Rural Health Services Project. 1982.
14. Papua New Guinea. Department of Health, Central Province. Proposed Rural Water Supply and Sanitation Programme for Central Province, Papua New Guinea. March 1985.
15. Papua New Guinea. Department of Health/Asian Development Bank Loan to Government of Papua New Guinea. Memorandum of Understanding. June 1982.

16. Papua New Guinea. Department of Healthm, Madang. College of Applied Health Sciences Curriculum for Health Inspector. 1985.
17. Sell, Jack. Technical Assistance for the Second Rural Health Services Project in Papua New Guinea. Consultant's Report on Water Supply and Sanitation. Social Infrastructure Division, Asian Development Bank. December 14, 1984.
18. Siunai, Peter S. Community Participation in Water and Sanitation Programme, a North Soloman's Case. Department of Health, Kieta. November 17, 1985.
19. Smith, D.E., and M.P. Alpers, Editors. Village Water Supplies in Papua New Guinea. Papua New Guinea Institute of Medical Research. Monograph No. 8. August 1985.
20. UNICEF. Handpump Caretaker Training. WASH Library No. G53.40.20, W03378. (No date.)
21. Water and Sanitation for Health Project. A Study of the Community Promotion Component of the Rural Sanitation Project in Bolivia. WASH Field Report No. 121. Arlington, VA. May 1984.
22. Wheeler, Mark. Report of Consultant Mark Wheeler (Financial Analyst). Papua New Guinea. Second Rural Health Services Project. July 22, 1985.
23. Whyte, Anne. Guidelines for Planning Community Participation in Water Supply and Sanitation Projects. Institute for Environmental Studies. University of Toronto. (No date.)
24. World Health Organization. Country Health Information Profile/Papua New Guinea. Revised May 1985.

APPENDIX A
Persons Contacted

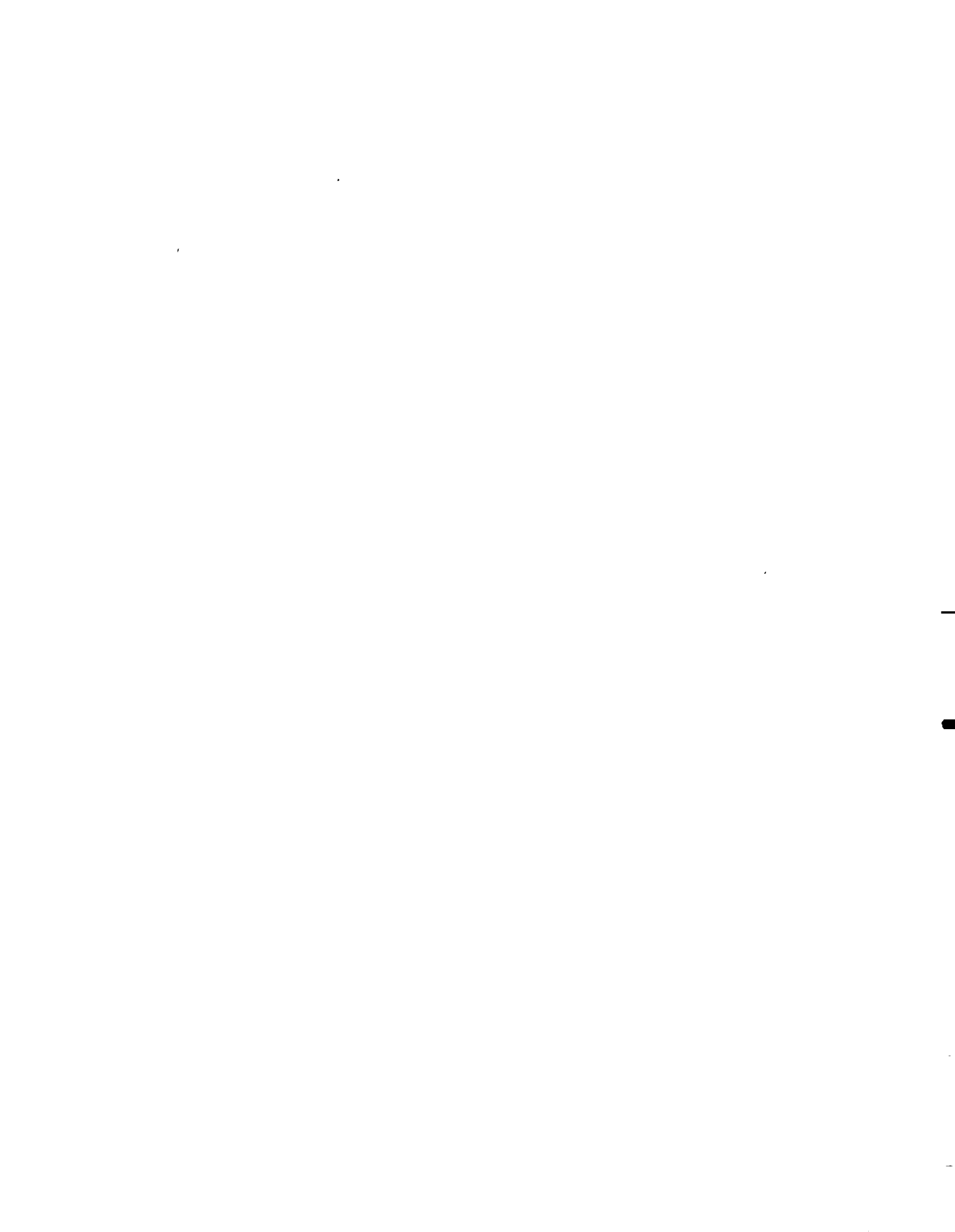

PERSONS CONTACTED

| | |
|-----------------------|---|
| MR. STEPHEN AMOS | OIC, EAST SEPIK |
| MR. MICHAEL ANDERSON | USIS, PNG |
| MR. STEPHEN ANI | OIC, CENTRAL PROVINCE |
| MR. EDDIE AVOSA | DEPUTY SECRETARY, GULF PROVINCE |
| MRS. MARY BIDDULPLH | DOH, PIU |
| DR. ROMEO CARTIER | WHO, MANILA |
| MR. H. K. CHANG | WHO, MANILA |
| MR. DONALD CLEVELAND | U.S. EMBASSY, PNG |
| MR. DAVIS COLLIN | DHI, TAMBUL |
| DR. LARRY COOPER | S&T HEALTH, AID |
| MR. DASE | DHI, BOGIA, MADANG PROVINCE |
| DR. WARRICK DAVIDSON | DOH, PIU |
| MR. RICHARD DAWANA | COLLEGE OF ALLIED HEALTH SCIENCES, MADANG |
| MR. ELI DEKEL | WHO, PNG |
| MR. AUGUSTINE DUNSTON | A/S, MADANG PROVINCE |
| MR. ELANGA EKANAYAKE | DOH, PIU |
| MR. MALI ENBOLO | DHI, MINJ, WESTERN HIGHLANDS |
| MR. WILLIE FEINBERG | SPATF, PNG |

| | |
|-----------------------|----------------------------------|
| MR. LUKE FURIGI | ACT'G. A/S, GULF PROVINCE |
| MR. KAOGA GALOWA | SR. HI, DOH |
| PAUL GARDNER | AMERICAN AMBASSADOR, PNG |
| MR. MICHAEL GHANDI | PHI, WESTERN HIGHLANDS |
| MR. WILL GUTHRIE | LGE, MADANG |
| MS. DEBORAH HUBBARD | ACT'G DIRECTOR, PEACE CORPS, PNG |
| MR. ROBERT HUBBARD | IHAP, DIRECTOR |
| MR. IAN HUNT | CSF, MELBOURNE |
| MR. JIM JORDAN | WASH |
| MR. THOMAS KALANA | PHI, MADANG PROVINCE |
| MR. BALTHASA KIPIT | OIC, WEST SEPIK |
| DR. WILFRIED KREISEL | WHO, MANILA |
| MR. KAMBOWA KUKYUNA | ACT'G A/S, WESTERN HIGHLANDS |
| DR. PATRICK LOWRY | USAID, SUVA |
| MR. DAVID MAKARI | CLERK, GULF PROVINCE |
| SISTER MARIA | OIC (NURSE), MALALAU, GULF |
| MR. BENJAMIN MARIN | OIC, MADANG PROVINCE |
| MR. MICHAEL MCGARRY | CO-WATER INTERNATIONAL, OTTAWA |
| MRS. DOROTHY MCINTOSH | SPATF, PNG |
| MR. MARK NAKGAI | PHI, EAST SEPIK |
| MR. ISIDOR NONORI | ACT'G A/S, WEST SEPIK PROVINCE |

| | |
|-------------------------|--|
| MR. LINDSAY PILIWAS | ASSISTANT SECRETARY, ENV. HEALTH, DOH |
| MR. JOHN POKAM | PHI, GULF PROVINCE |
| DR. MICHAEL PORTER | WORLD BANK (EX--ADB) |
| MR. NORMAL POWAI | PHI, WEST SEPIK |
| MR. GARY PRESTHUS | WHO, MANILA |
| MR. ROBERT PRINGLE | DCM, U.S. EMBASSY, PNG |
| DR. QUENTIN REILLY | SECRETARY OF HEALTH, DOH |
| MR. LINDSAY ROCKETT | CAMP, SCOTT, FURPHY PTY. LTD., PNG |
| MR. GARY RUITER | WHO, PNG |
| DR. J. SAIRERE | A/S, EAST SEPIK PROVINCE |
| MR. GUENTER SEIDEL | DOH, PIU |
| DR. LEVI SIALIS | DEPUTY SECRETARY, DOH |
| MR. PETER SILIWEN | PHI, GULF PROVINCE |
| MR. PATRICK SONDERGAARD | UNICEF, MANILA |
| DR. DRAGAN STERN | WHO, PNG DIRECTOR |
| MS. VIRGINIA STIMER | PRINCIPAL, NAZARENE COLLEGE OF NURSING, W. HIGHLANDS |
| MRS. JANE THOMASON | PROJECT COORDINATOR, DOH, PIU |
| MR. OREME TIPO | PHEO, CENTRAL PROVINCE |
| MR. EMIL TROWALLE | HI, GULF PROVINCE |
| MR. EGI VALAHU | PHI, CENTRAL PROVINCE |
| MS. LINDA VORHIS | PNG DESK OFFICER, PEACE CORPS, WASHINGTON, D.C. |

MR. CHRISTOPHER WALKER ADB, MANILA

MR. EMO ALFRED WAPIRI OIC, WESTERN HIGHLANDS

MR. E. S. WEBBER PRINCIPAL ENGINEER, NWS & SB

MR. JOHN WINFIELD ASSOCIATE DIRECTOR, PEACE CORPS, PNG

MR. CESAR YNIGUEZ UNICEF, MANILA

APPENDIX B
Summary of Field Visit Data

VILLAGE WATER SUPPLY
SUMMARY OF FIELD VISIT DATA

| DATE OF VISIT | PROVINCE VILLAGE 1980 POPULATION | TYPE OF SYSTEM | TYPE OF SOURCE | PUMPS, GALLONS, OR TAPS | YEAR BUILT | YEAR FIXED | CONDITIONS |
|---------------|--|---------------------------------|------------------------|-------------------------------|------------|------------------------|--|
| | <u>CENTRAL PROVINCE</u> | | | | | | |
| 31/1 | Caire - 1125 | Retic. | Borehole | 12,000 | 1983 | Pending | Not Operating |
| 31/1 | Dagoda - 83 | H/Pump | Auger | PNG | 1985 | - | Fair |
| 31/1 | Seme - 91 | H/Pump | Auger | PNG | 1985 | - | Poor |
| 31/1 | Barakau - 496 | Retic. | Borehole (Windmill) | 6 Taps (Bank) | 1983 | - | Not Operating |
| 31/1 | Tubusereia - 1161 | Retic. (Motor & Windmill) | Borehole (B) | 4 Taps (Bank) | 1983 | - | Not Operating |
| 4/3 | Papa | Retic. | Borehole (Windmill) | 4 Taps (Bank) | 1972? | 1983? (Diesel pump) | Not Operating |
| 4/3 | Boera | Retic. | Borehole (Solar) | 9 Taps | 1980 | 1983 (ADB Pipe) | Not Operating (Handpump installed) |
| 4/3 | Porebada | Retic. | Pt. Moresby System | 5 Taps (Bank) | 1972? | 1986 | Good (No ADB Funds) |
| 5/3 | GabaGaba | Retic. | Borehole | 12 Taps | 1984 | - | Not Operating |
| 5/3 | Kaparoko | Retic. | Borehole | 4 Taps (Bank) | 1984 | - | Not Operating |
| 5/3 | Boregaira | Retic. | River | 5 Taps | 1984 | 1986 | Not Operating |
| 5/3 | Kwikila H/C | Tanks | Rain | 2 x 1000 G. | 1985 | - | Not Operating |
| 5/3 | Rabuka | H/Pump | Aug er | 2 - PNG | 1983/85 | - | Good |

VILLAGE WATER SUPPLY
SUMMARY OF FIELD VISIT DATA

| DATE OF VISIT | PROVINCE VILLAGE 1980 POPULATION | TYPE OF SYSTEM | TYPE OF SOURCE | PUMPS, GALLONS, OR TAPS | YEAR BUILT | YEAR FIXED | CONDITIONS |
|--------------------------|--|----------------|----------------|-------------------------------|------------|------------|------------------------|
| <u>GULF PROVINCE</u> | | | | | | | |
| 4/2 | Malalaua H/C | H/Pump | Dug Well | Onga | 1984? | Pending | Not Operating |
| 4/2 | Malalaua | H/Pump | Dug Well | Onga | 1982? | - | Good |
| 4/2 | Koaru S/C | H/Pump | Dug Well | Fuji | 1983 | 1985 | Good (Onga Replace) |
| 4/2 | Karama A/P | H/Pump | Dug Well | Fuji | 1983 | - | Good |
| <u>WESTERN HIGHLANDS</u> | | | | | | | |
| 18/2 | Djeck | Retic. | Spring | 8 Taps | 1984 | 1985 | Good |
| 18/2 | Nondugl H/C | H/Pump | Dug Well | Wilson | 1983 | - | Good |
| 18/2 | Jimbina Church | Tank | Rain | 2000 Gal. | 1984 | - | Good |
| 18/2 | Jimbina | H/Pump | Dug Well | UNICEF | 1984 | - | Fair |
| 18/2 | Raphael C/S | Tanks | Rain | 2 x 2000 G | 1985 | - | Good |
| 18/2 | Minj H/C | Tanks | Rain | 5 x 2000 G | Various | - | Good |
| 19/2 | Kaul C/S | Retic. | Spring | 1 Tap | 1983 | 1985 | Fair |
| 19/2 | Kawi | Retic. | River | 7 Taps | 1983 | - | Good |
| 19/2 | Avi Settle. | H/Pump | Dug Well | UNICEF | 1985 | - | Not Operating |

VILLAGE WATER SUPPLY
SUMMARY OF FIELD VISIT DATA

| DATE OF VISIT | PROVINCE VILLAGE 1980 POPULATION | TYPE OF SYSTEM | TYPE OF SOURCE | PUMPS, GALLONS, OR TAPS | YEAR BUILT | YEAR FIXED | CONDITIONS |
|---------------|--|----------------|----------------|-------------------------------|------------|------------|---------------------|
| | <u>WESTERN HIGHLANDS</u> | | | | | | |
| 19/2 | Wau | H/Pump | Dug Well | UNICEF | 1985 | - | Fair |
| 20/2 | Tambul C/S | H/Pump | Dug Well | Wilson | 1983 | - | Good |
| 20/2 | Lamdi | Retic. | Spring | 1 Tap | 1985 | - | Good |
| 20/2 | Pombil | Retic. | Spring | 5 Taps | 1984 | 1985 | Good |
| 20/2 | Pugumong | Retic. | Spring | 5 Taps | 1984 | - | Good |
| | <u>EAST SEPIK</u> | | | | | | |
| 24/2 | Parom - 281 | Retic. | Creek | 6 Taps | 1982 | - | Good |
| 24/2 | Gringring - 405 | H/Pump | Auger | PNG | 1985 | 1986 | Good (Onga Replace) |
| 24/2 | Kofi - 120 | H/Pump | Auger | PNG | 1985 | 1985 | Good (Onga Replace) |
| 24/2 | Banak/ Bogametai - 174 | Retic. | Spring | 10 Taps | 1983 | - | Fair |
| 25/2 | Maprik H/C | Tanks | Rain | 2 x 2000 G | 1983 | - | Good |
| 25/2 | Bongiora - 257 | H/Pump | Dug Well | Fuji | 1981 | 1985 | Good (Onga Replace) |

VILLAGE WATER SUPPLY
SUMMARY OF FIELD VISIT DATA

| DATE OF VISIT | PROVINCE VILLAGE 1980 POPULATION | TYPE OF SYSTEM | TYPE OF SOURCE | PUMPS, GALLONS, OR TAPS | YEAR BUILT | YEAR FIXED | CONDITIONS |
|---------------|--|----------------|----------------|-------------------------------|------------|------------|---------------------------------|
| | <u>EAST SEPIK</u> | | | | | | |
| 25/2 | Warabung A/P - 361 | Tank | Rain | 1000 Gal. | 1985 | - | Good |
| 25/2 | Hanyak | H/Pump | Dug Well | Lucky | 1981 | Pending | Good (Onga Replace) |
| 25/2 | Paparam A/P | Tank | Tain | 1000 Gal. | 1984 | - | Good |
| 25/2 | Urigembi - 289 | H/Pump | Dug Well | Fuji | 1970's | 1985 | Not Operating (Onga Replace) |
| | <u>WEST SEPIK</u> | | | | | | |
| 12/2 | Waromo | Retic. | Spring | 12 Taps | 1985 | 1985 | Good |
| | <u>MADANG PROVINCE</u> | | | | | | |
| 27/2 | Korak (RIP) | Retic. | Seepage | 8 Taps | 1979 | - | Fair |
| 27/2 | Sikor (NPEP) | Retic. | Seepage | 4 Taps | 1982 | - | Fair |
| 27/2 | Toto (WHO) | Retic. | Spring | 3 Taps | 1978 | 1980 | Fair |

VILLAGE WATER SUPPLY
SUMMARY OF FIELD VISIT DATA

| DATE OF VISIT | PROVINCE VILLAGE 1980 POPULATION | TYPE OF SYSTEM | TYPE OF SOURCE | PUMPS, GALLONS, OR TAPS | YEAR BUILT | YEAR FIXED | CONDITIONS |
|---------------|--|----------------|----------------|-------------------------------|------------|--------------|--------------------------|
| | <u>MADANG PROVINCE</u> | | | | | | |
| 27/2 | Malala C/S | H/Pump | Dug Well | Fuji | 1978 | 1985 | Good (Onga Replace) |
| 27/2 | Simbina | Retic. | Spring | 7 Taps | 1983 | 1984 | Fair (Pipeline Extended) |
| 27/2 | Bonaputa | Retic. | Seepage | 5 Taps | 1986 | - | Good |
| 28/2 | Mambuan | Retic. | Spring | - | Under | Construction | |
| 28/2 | Aronis | Retic. | Spring | Several | 1979-84 | - | Fair |
| 1/3 | Kamba A/P | Tank | Rain | 2 x 1000 | 1983 | 1986 | Good/Fair |
| 1/3 | Panim A/P | Tank | Rain | 1000 | 1984 | - | Good |

APPENDIX C

National Policy for Rural Water Supply and Sanitation

NATIONAL POLICY FOR RURAL WATER SUPPLY AND SANITATION

POLICY STATEMENT: GOALS AND OBJECTIVES

| NO: | POLICY | OBJECTIVES/STRATEGY | TARGET | AGENCY |
|-----|--|--|--|--|
| 01/ | The Goal is the improvement of health & quality of life of the rural population through a combined programme of installation of water supplies, sanitation and health education. | The 5 yr objective is to bring adequate supply of safe drinking water within 15 minutes walking distance to 80% of the population. (To be measured in the 1990 population census). Targets for sanitary disposal facilities will be established by the individual provinces upon completion of the inventory of existing facilities. | The 10 year target is to achieve 100% for the above. | Provinces with the support of the National Department of Health as required. |
| 02/ | That priority be given to <u>simple schemes</u> that can be constructed, operated, and maintained by the community. | Evaluation of existing schemes, promotion of tested reliable technology, training of Sector manpower. | Guidelines and criteria for selection of schemes ready by June 85 evaluation of existing schemes by June 86. | DOH in cooperation with Local Government Section and Provinces. |
| 03/ | To increase the capabilities of Provincial and community governmental bodies for installation, <u>management</u> and maintenance of water supply & sanitation systems, and conduct of necessary health education programmes. | Conduct provincial surveys (inventories of existing facilities) & determine needs. Develop training programmes on planning, management, administration and construction of simple schemes, maintenance and repair, Health Education and community participation. | 1985 Target: the completion of inventories & surveys of needs for all provinces. 1986 Target: completion of Provincial capabilities as follows:- (a) Provincial water supply/ sanitation programme developed and approved. (b) Provincial water supplies/ sanitation committee established. (c) Provincial water supply/ sanitation depot, <u>transport</u> and manpower. (d) Maintenance and rehabilitation systems. (e) Relevant Health education capability. (f) Appropriate revenue system. | Department of Province, in collaboration with the National Department of Health. (Role of Provincial Government to be clarified). And local government Section. |

-78-

| NO: | POLICY | OBJECTIVES/STRATEGY | TARGET | AGENCY |
|-----|--|---|--|--|
| 04/ | To increase the self-reliance, awareness and responsibility of communities and private owners in the operation and maintenance of water supplies and sanitation facilities. | Health Education & involvement of community in all stages of Project development from source selection to funding construction, maintenance and repair. | <p>1987 Goal: full implementation within each province of appropriate guidelines involving:-</p> <p>(a) Standard approaches to community installations involving prior consultation, involvement and participation of the community, and financial contributions. (Annex I: draft implementation policy for community participation).</p> <p>(b) Agreement and where indicated formal handover once the legal status of supplies is clarified.</p> | Provincial Government DOH Local Government Section |
| 05/ | To ensure the installation of proper water supplies & sanitation to all government institutions especially education and health, both by ensuring this is carefully planned according to the Public Health Act, and other appropriate legislation for all new institutions and by upgrading and installing new systems in those now deficient. | No new institutions be permitted without provision of adequate facilities. Existing facilities to be surveyed, to determine needs, costs and funding. | Full coverage by 1988. | Provincial Governments, Divisions and formal bodies. |
| 06/ | To set up and operate national network of procurement, supply, technical advise assistance to the Provincial Agencies responsible for water supply and sanitation. | <ul style="list-style-type: none"> * National Water & Sewerage Board to delegate powers to the Dept of Health. * A National Committee for Water Supply/ Sanitation to be set up under the Dept of Health, or under National Water Board if this becomes a statutory body. | <p>Delegation of power to DOH by end of 1984.</p> <p>National Committee for water Supply and Sanitation to be established by Jan 1985.</p> <p>National Network for procurement supply and technical advice be set up by June 1985.</p> | <ul style="list-style-type: none"> - Water Board MOH Provinces LGs |

| NO: | POLICY | OBJECTIVES/STRATEGY | TARGET | AGENCY |
|-----|---|---|--|--|
| 07/ | * National DOH to set up systems for information exchange and dissemination, including a quarterly newsletter and seminars and workshops as required. | Provide up-to-date information to the provinces on appropriate technology, approaches and achievements. | Information exchange/dissemination system to be set up by June 1985. | DOH, Water Board JMR, LGS. |
| 08/ | To effect the standardisation as far as possible of equipment and systems used, through liaison, consultation and accordance with agreed Policies. | Minimize needs for spare parts, training, O & M, and repair costs. | * National DOH to set up a standards sub-committee by early 1985 under the National Committee. * Codes of practice for all aspects of the programme to be developed with full consultation with the Provinces by the end of 1985. | DOH, Water Board JMR LGS |
| 09/ | To develop and maintain a standard system of reporting, monitoring and evaluation, both for the needs and programmes and the equipment and systems in use This to include the problem of maintenance and upkeep and the necessity to continually increase the involvement of communities and their local governments in the upkeep of their systems. | Monitoring and evaluation of needs, Progress of implementation, adequacy of technology. | Trial reporting systems to be in use by 1.4.85, with inception for all provinces on 1.1.86. | DOH Provinces Water Board LGS |
| 10/ | To develop a provincial capability for the monitoring and surveillance of water quality. | Assuring supply of safe water through routine monitoring and surveillance. | Full operation by 1.1.86 | DOH Provinces |
| 11/ | The delegation of responsibility among different government agencies for implementation of the above policy as approved by the Water Board is given in Annex. | | | |

APPENDIX D

National Water Supply and Sewerage Board,
Policies for Implementation

NATIONAL WATER SUPPLY AND SEWERAGE BOARD

POLICIES FOR IMPLEMENTATION OF THE

NATIONAL WATER SUPPLY AND SEWERAGE ACT 1982

PREAMBLE: Section 1 of the Act.

"1. - THE PURPOSES OF THIS ACT.

The purposes of this Act are to establish a National Water Supply and Sewerage Board and to charge it with the duty of co-ordinated planning, design, construction, management of, and charging for, water and sewerage facilities throughout the country."

GENERAL

Implementation of policy in Water Districts and Sewerage Districts will be under the direct control of the Board or its agents. In any other centre, authorisation from the Board is required for implementation undertaken by bodies such as National Government authorities (e.g. Department of Works, Local Government Section; Department of Works, Static Plant Section); Provincial Governments ; Local Government Councils; Statutory Authorities; missions; private enterprise; etc.

The Board's responsibility covers all sectors of the community throughout the country. Assessment shall be on a global basis to achieve minimum costs to the community as a whole, not only to the National Government.

PARTICULAR POLICIES

1. BOARD'S OVERALL RESPONSIBILITY

1.1 Board to Extend Direct Control

The Board is to bring under its control - through the declaration of Districts - water and sewerage facilities as follows:

- (a) Nationally administered water supplies plus Port Moresby, Goroka, Arawa and Rabaul, concentrating on the larger towns first.
- (b) Nationally administered sewerage facilities plus Port Moresby.

1.2 Delegation of Rural Systems to Department of Health

In the period to 1990, water supply and sanitation facilities in rural areas will remain the primary responsibility of the Department of Health. As the Board has delegated it's overall responsibility to the Department of Health, it will limit it's involvement to chairing a subsidiary committee, which shall include all interested or affected parties, to co-ordinate policy on water supplies and sanitation in rural areas.

1.3 **Authorisations to Other Bodies**

Other authorities, persons, bodies, etc., may be authorised by the Board, under Sections 18 (1) and 33 (1) of the Act, to construct, maintain, operate and collect revenue for facilities administered by them.

1.4 **Approvals at Each Stage**

Where other authorities, persons, bodies, etc., wish to investigate, construct or operate any water supply or sanitation facility in which government (includes National, Provincial, and Local Governments and Statutory Authorities) funds are involved, or in which privately developed infrastructure is to be handed over to a government body, the Board must be informed and give approvals at each stage from inception to completion.

For non-government infrastructure, the Board must be informed and give approvals as determined in each case.

2. **COST RECOVERY AND TARIFFS IN BOARD DISTRICTS**

2.1 **Full Cost Recovery**

The Board is to ensure that the full cost of urban water and sanitation facilities is recovered from users of the system. In particular, the Board will seek to achieve full cost recovery within declared water and sewerage Districts by 1990. A tariff shall be set to reflect this policy.

2.2 **Tariffs to be Progressive**

The Board will set a progressive tariff which favours consumers who use small quantities of water per connection.

2.3 **Uniform National Tariff**

The Board supports cross-subsidisation between Districts in order to set a uniform national tariff.

3. OPERATION, CONSERVATION AND EDUCATION

3.1 Operation of Existing Systems

The Board is to ensure the continued operation of all existing systems in the following order:

- (a) systems in declared Board Water or Sewerage Districts;
- (b) national systems operated by the Department of Works;
- (c) systems under provincial or local government administration; and
- (d) all other systems operating within the country.

3.2 Conservation and Education in Water Supply Usage

The Board will investigate and implement conservation methods in declared Water Districts in order to manage demand for water. The investigations will be programmed to look at districts:

- (a) where unaccounted-for water is an acute problem, and
- (b) where an augmentation requirement is imminent.

Methods are to include a publicity and education programme on water conservation.

The Board will assist, where possible, with conservation and education in water supply usage generally throughout the country.

4. CAPITAL WORKS

4.1 Medium Term Development Programme (MTDP)

All submissions for funding of water supply or sewerage facilities in urban areas from the MTDP shall be directed in the first instance to the Board. Such submissions will be forwarded to the Department of National Planning and Development for consideration by the Medium Term Development Strategy (MTDS) assessment bodies according to priorities set by the Board, provided that they fall within the technical and economic criteria of the MTDS and that they fall within any overall funding request ceiling set by the National Government.

4.2 Appropriate Levels of Service

For augmentations and new systems the Board will seek to develop facilities through the provision of appropriate levels of service. Emphasis will be placed on simplicity, reliability, and cost effectiveness consistent with quality and capacity requirements.

For sanitation requirements, the Board will consider every alternative, particularly on-site systems, and recommend the system most appropriate for a particular site.

APPENDIX E

National Water Supply and Sewerage Board,
Areas of Responsibilities and Delegation

NATIONAL WATER SUPPLY & SEWERAGE BOARD

WATER SUPPLY & SANITATION - AREAS OF RESPONSIBILITY AND DELEGATIONS BY THE BOARD

| TYPES OF SYSTEM(EXAMPLES) | POLICY & STANDARDS | PROJECT SELECTION & BUDGET ALLOCATION | INVESTIGATION & DESIGN | GROUND-WATER PROTECTION ABSTRACTION DISPOSAL | TECHNICAL APPROVAL (LICENSE) | SUPPLY/ CONSTRUCTION | OPERATION & MAINTENANCE | QUALITY MONITORING |
|---|--------------------|---------------------------------------|------------------------|--|------------------------------|-----------------------------------|-------------------------|--------------------|
| SAMPLE Transported by tanker Handpumps, wells Minor gravity pipelines (1 km long) Rainwater / tank Onsite sewage disposal | DoH | PG | PG | Licensed by BWR | DoH with reference to NWSSB | Community served & P.G. | Community served | DoH |
| Sanitary pan collection | DoH | PG | PG | BWR | DoH | PG | PG | N/A |
| INTERMEDIATE Small power pumped system Chlorination only. Solar / Wind pumps Water-ram pumps Gravity system 1km Single borehole | NWSSB DoH | PG | PG & DWS LG | BWR | DWS LG with ref. to NWSSB | PG | PG & DWS Stratic Plant | DoH |
| Sanitation (None) | N/A | N/A | N/A | N/A | N/A | N/A | N/A | N/A |
| COMPLEX Well-field Development Sanitary pan Disposal Fuller Treatment (Water or Sewerage) Reticulated system (water or sewerage) Larger powered pumps | NWSSB | National Government | NWSSB | BWR & OE | NWSSB | NWSSB through DWS and/or contract | NWSSB | DoH |

ABBREVIATIONS:

DoH
PG
N/A
O.E

Department of Health
Appropriate Provincial or Local Govt.
Not Applicable
Office of Environment

NWSSB
BWR
DWS LG

National Water Supply/Sewerage Board
Bureau of Water Resources
Dept of Works/Supply (Local Govt) Section

NATIONAL WATER SUPPLY & SEWERAGE BOARD
WATER SUPPLY & SANITATION - AREAS OF RESPONSIBILITY FOR IMPLEMENTATION

| TYPE OF SYSTEM (Examples) | Policy & Standards | Project Selection & Budget (Allocation (See Note 1)) | Investigation & Design | Groundwater Protection, Abstraction & Disposal | Technical Approval (License) | Supply/Construction | Operation, Maintenance & Revenue Collection | Quality Monitoring |
|---|--------------------|--|------------------------|--|------------------------------|-----------------------|---|--------------------|
| A. SIMPLE A1. Transported by tanker A2. Hand pumps, wells, etc. A3. Minor gravity pipelines (< 1 km long) A4. Rainwater & tank A5. All simple rural supplies | DoH | PG or DoH | DoH | Licensed by BWR | DoH | Community served & PG | Community served | DoH |
| A6. On-site sewage disposal | DoH | PG or DoH | DoH | BWR | DoH | " | " | DoH |
| A7. Sanitary pan collection | DoH | PG | PG | BWR | DoH | PG | PG | DoH |
| B. INTERMEDIATE B1. Small powered pumped systems B2. Chlorination only B3. Water ram, Solar & Wind pumps B4. Gravity systems (> 1 km long) B5. Single shallow boreholes | Board | PG or DoH | DoWLG | BWR | DoWLG | PG | PG or DoWSP (under licence from the Board) | DoH |
| B6. Sanitation | N/A | N/A | N/A | N/A | N/A | N/A | N/A | N/A |
| C. COMPLEX C1. Larger powered pumps C2. Wellfield Development C3. Fuller treatment (Water or Sewage) C4. Reticulated mains system (Water or Sewerage) C5. Sanitary Pan Disposal | Board | National Government on Board recommendation. | Board | BWR and OE | Board | DoWCB and/or contract | Board or DoWSP (under licence from the Board) | DoH |

ABBREVIATIONS: DoH - Department of Health
Board - National Water Supply & Sewerage Board (Waterboard)
PG - Appropriate Provincial or Local Government
BWR - Bureau of Water Resources
N/A - Not applicable
DoWLG - Department of Works, Local Government Section
OE - Office of Environment
DoWCB - Department of Works, Construction Branch
DoWSP - Department of Works, Static Plant Section

Note 1. Not applicable to developments in the private sector.

NATIONAL WATER SUPPLY & SEWERAGE BOARD
WATER SUPPLY & SANITATION - DELEGATION OF POWERS FROM THE BOARD

| TYPE OF SYSTEM (Examples) | Policy & Standards | Project Selection & Budget Allocation (See Note 1) | Investi- gation & Design | Groundwater Protection, Abstraction & Disposal | Technical Approval (License) | Supply/ Construction | Operation, Maintenance & Revenue Collection | Quality Monitoring |
|---|-----------------------|--|-----------------------------------|---|------------------------------------|-------------------------|--|---|
| A. SIMPLE A1. Transported by tanker A2. Hand pumps, wells, etc. A3. Minor gravity pipelines (< 1 km long) A4. Rainwater & tank A5. All simple rural supplies | DoH | DoH | DoH | N/A | DoH | DoH | DoH | N/A |
| A6. On-site sewage disposal | DoH | DoH | DoH | N/A | DoH | DoH | DoH | N/A |
| A7. Sanitary pan collection | DoH | PG | PG | N/A | DoH | PG | PG | N/A |
| B. INTERMEDIATE B1. Small powered pumped systems B2. Chlorination only B3. Water ram, Solar & Wind pumps B4. Gravity systems (> 1 km long) B5. Single shallow boreholes | Board | PG | PG | N/A | DoWLG | PG | PG | N/A |
| B6. Sanitation | N/A | N/A | N/A | N/A | N/A | N/A | N/A | N/A |
| C. COMPLEX C1. Larger powered pumps C2. Wellfield Development C3. Fuller treatment (Water or Sewage) C4. Reticulated mains system (Water or Sewerage) C5. Sanitary Pan Disposal | Board | Board | Board | N/A (as licences) are issued by the BWR) | Board | Board | Board | N/A (as this is carried out by the DoH) |

ABBREVIATIONS: DoH - Department of Health
Board - National Water Supply & Sewerage Board (Waterboard)
BWR - Bureau of Water Resources
N/A - Not applicable
DoWLG - Department of Works, Local Government Section
PG - Appropriate Provincial or Local Government

Note 1. Budget allocation etc. not applicable to developments in the private sector.
2. Where powers are delegated, reference should be made back to the Board in cases where the delegate has insufficient expertise.
3. Where Board indicated, no delegation is implied.

APPENDIX F
Project Consultants

Project Consultants

| ADB-1 | | ADB-2 | |
|---------------------------------------|----------|--|--------------|
| Health educator | 3 years | Manpower planner | 4 months |
| Health services management | 2 years | Curriculum and materials development | 2 years |
| Micro-computer information specialist | 2 years | Materials preparation and production | 3 months |
| Sanitary engineer | 2 years | Sanitary engineer | 12 months |
| Architect | 3 months | Water and sanitation specialist/trainer | 9 months |
| Quantity surveyor | 3 months | | |
| Project coordinator | 5 years | <u>Cost Study Team</u> Health economist | 3 months |
| Project accountant | 5 years | Health planner | 4 to 5 weeks |
| | | Communications specialist/writer | 8 weeks |

APPENDIX G
Provincial Organization Charts

-105-

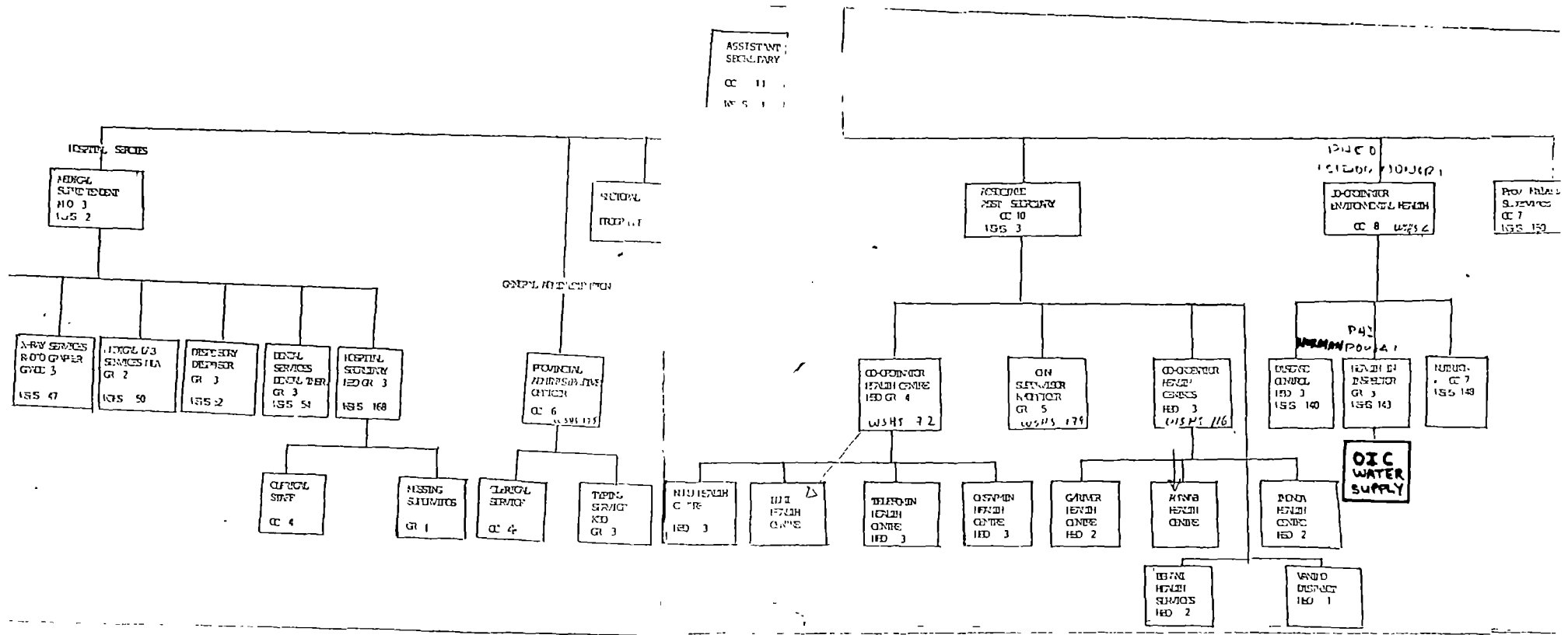

WEST SERRIN

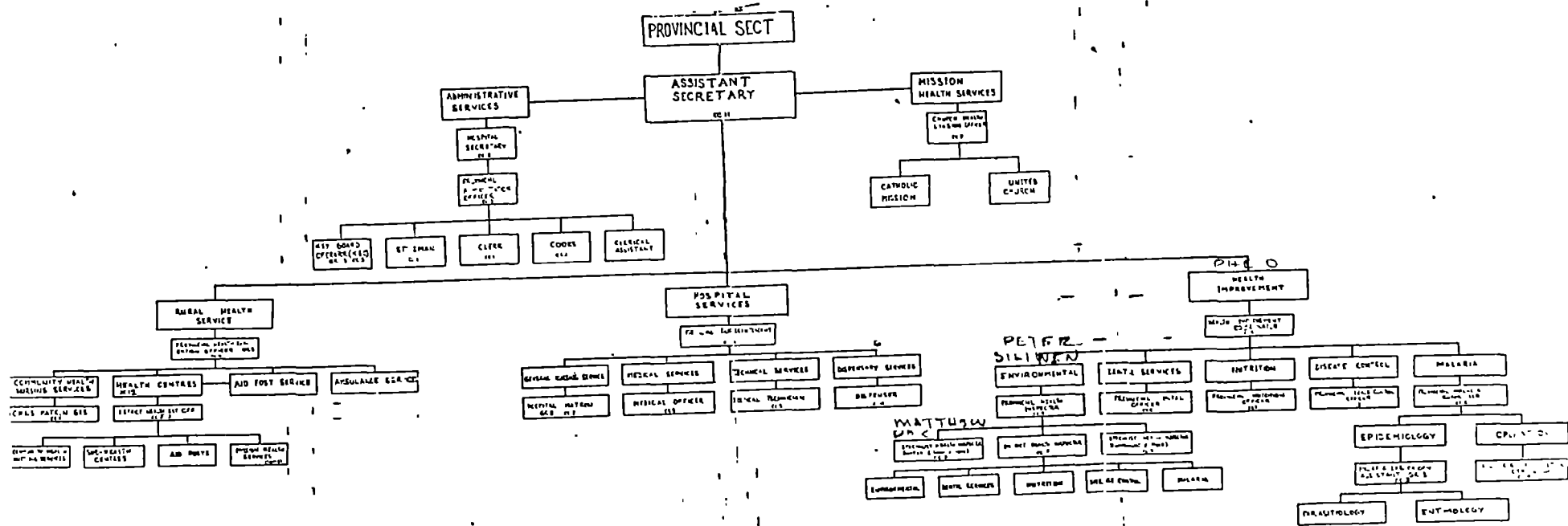

Assistant Sec. Health
cc n.

PROVINCIAL HEALTH SERVICES

MEDICAL SERVICES

MEDICAL SUPERINTENDENT MO

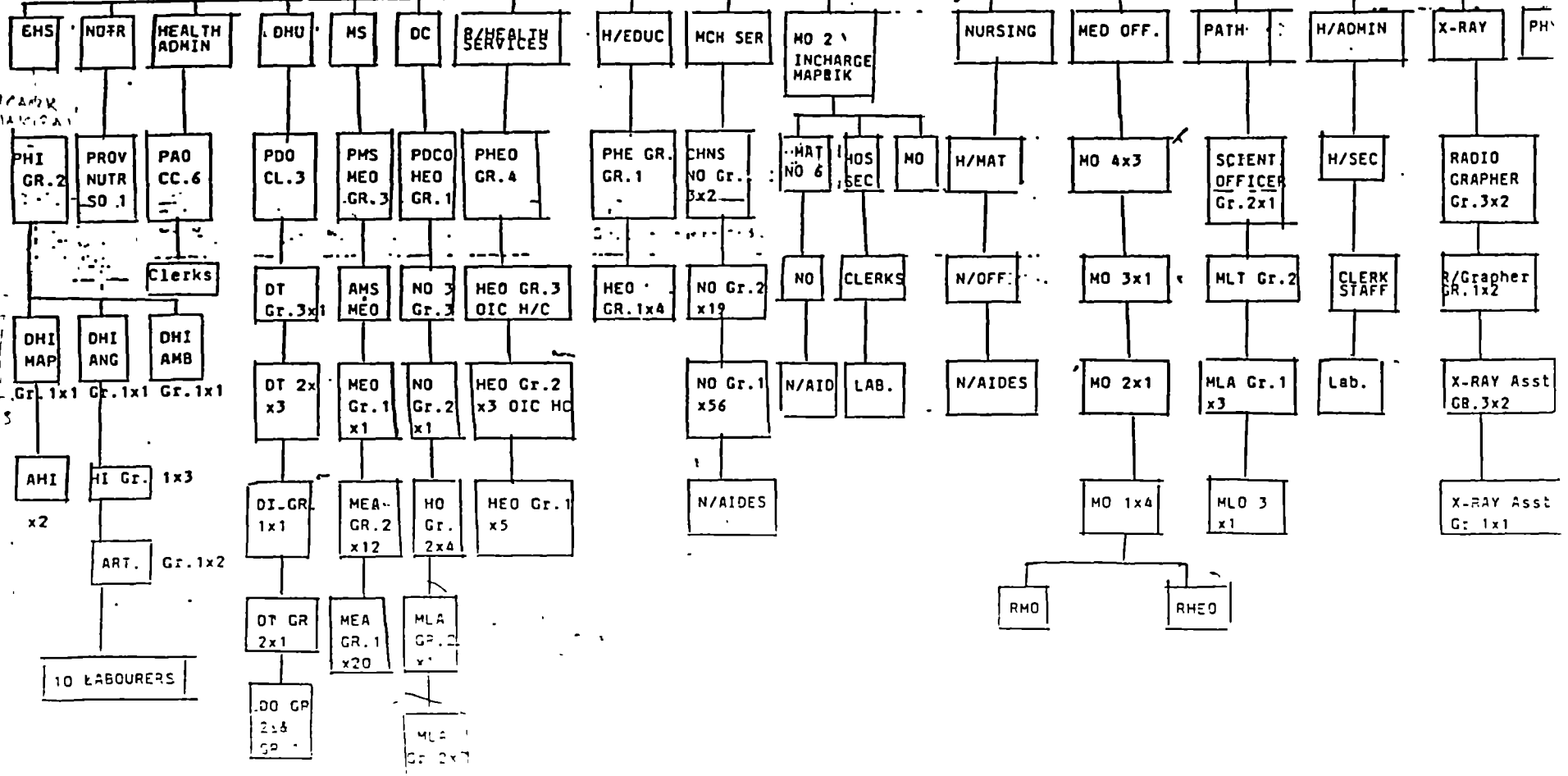

STAFF STRUCTURE - DIVISION OF HEALTH - MUMBAI

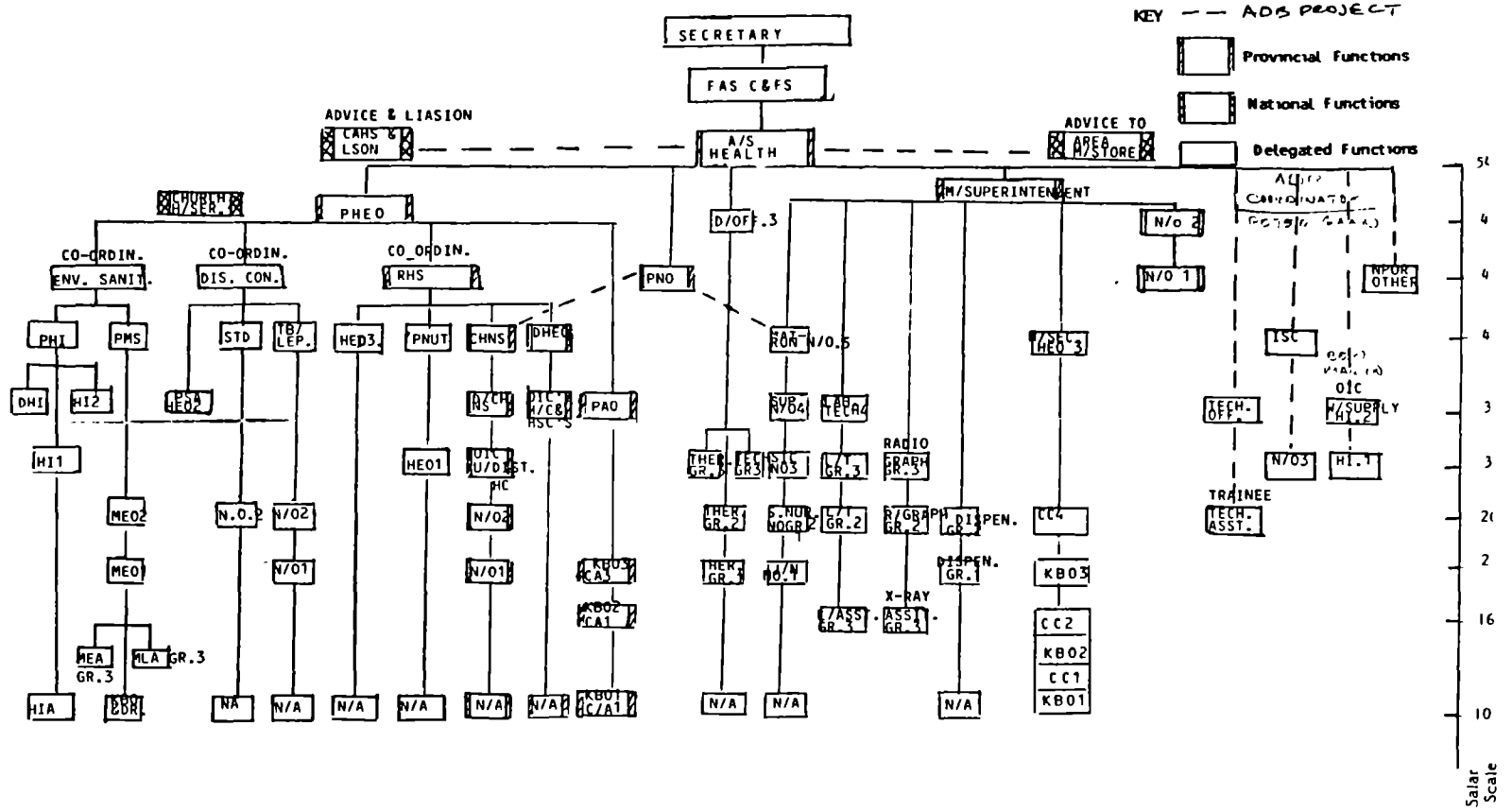

1986 — DIVISIONAL STRUCTURE: HEALTH

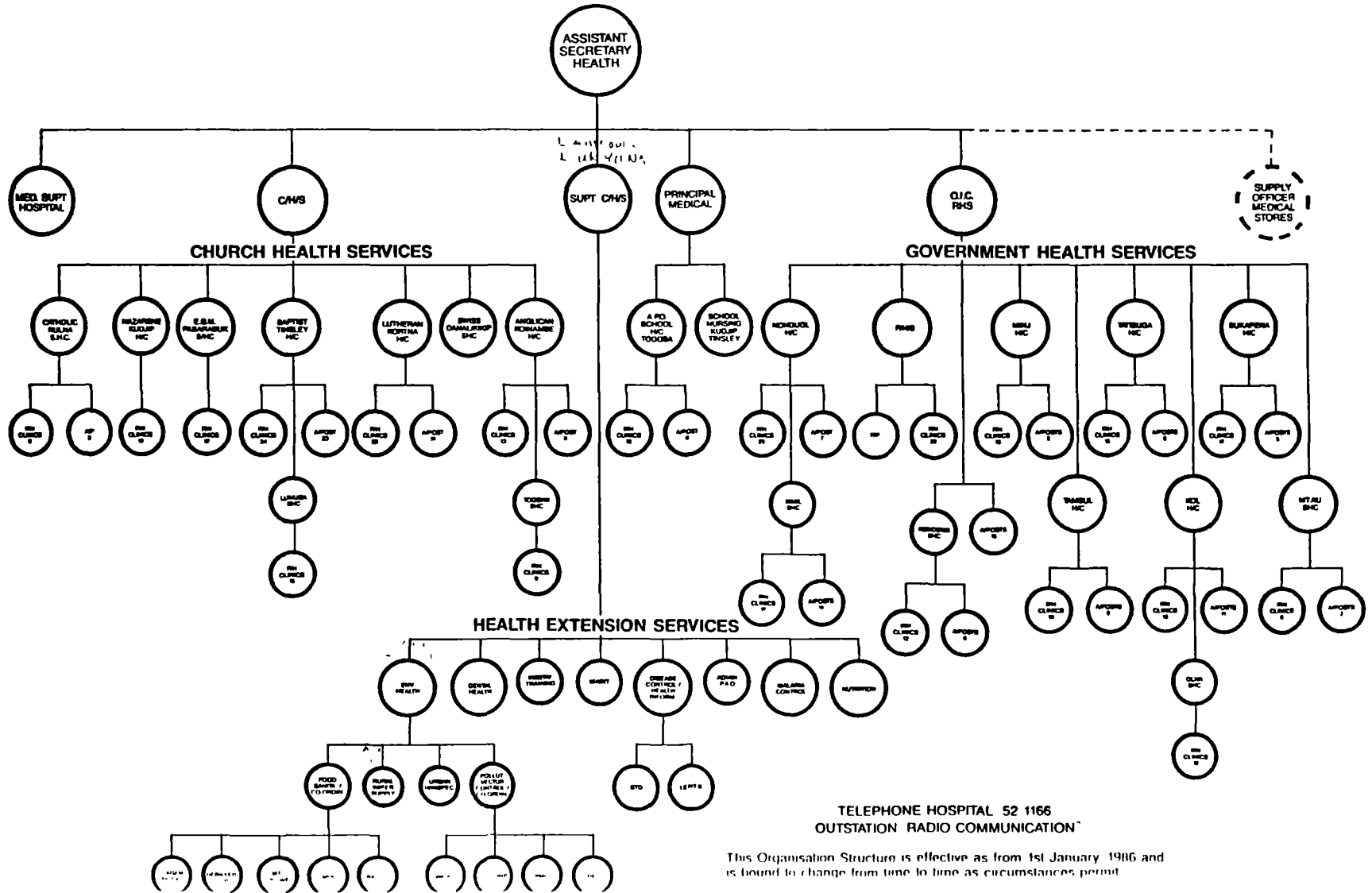

-109-

This Organisation Structure is effective as from 1st January 1986 and is bound to change from time to time as circumstances permit

W.S. STEVENSON

APPENDIX H

List of Village Water Supply Surveys

Survey of Village Water Supplies*
Department of Lands, Surveys and Mines

| <u>Name of Province</u> | <u>Date</u> | <u>Reference Number</u> |
|-------------------------|-------------|-------------------------|
| Western Highlands | - | G.E. Branch No. 78 |
| Eastern Highlands | - | G.E. Branch No. 72 |
| Southern Highlands | 1971 | R-50 |
| West Sepik | 1966 | R-81 |
| East Sepik | 1966 | R-82 |
| Madang | - | 74/8 |
| Northern | - | R-71 |
| Western | 1967 | R-74 |
| Gulf | 1967 | R-85 |
| New Ireland | 1971 | R-65 |
| New Britain: | | |
| South Coast | 1968 | R-67 |
| North Coast | 1968 | R-66 |
| Bougainville | 1969 | R-51 |
| East New Britain | | |
| N.E. Gazelle Peninsula | 1968 | R-84 |

*Information obtained from the National Water Supply and Sewerage Board Library.

APPENDIX I

Sample Village Water Supply Survey

SURVEY OF VILLAGE WATER SUPPLIES ... EAST SERIK DISTRICT

VILLAGE ... KREER

COUNCIL ... Wewak But

CENSUS DIVISION ... Wewak But

SUB-DISTRICT ... Wewak

POPULATION

ACCESS ... Road

.....

~~HEADMAN~~/COUNCILLOR ... KARGAI

.....

WATER USE - Domestic/Government School/
Mission/Mission School/Hospital/First Aid/
Stock/Irrigation

PROJECTED DEVELOPMENT

.....

ESTIMATED DEMAND

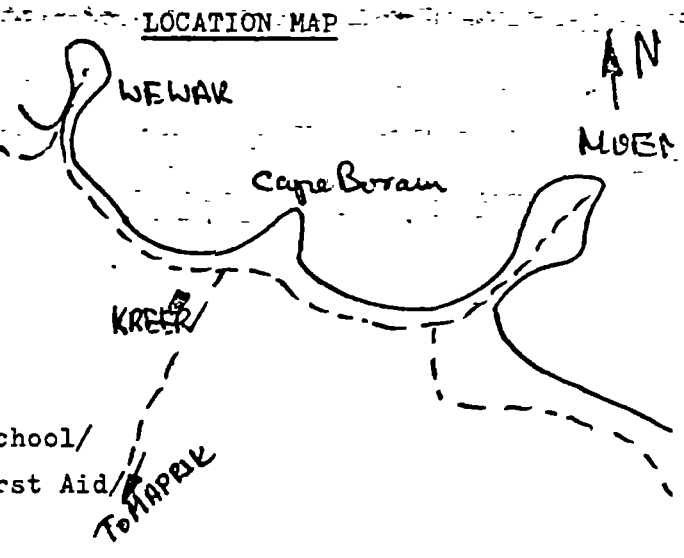

PRESENT SUPPLY

RAINFALL

WET SEASON From to

TYPE Pipeline from dammed spring ...

DISTANCE FROM VILLAGE Central

TRANSPORT .. Road

YIELD/RATE OF FLOW

QUALITY - Chemical

 Bacteriological

PROTECTION ... Nil

REMARKS

.....

.....

.....

DRY SEASON From to

TYPE ... As above

DISTANCE FROM VILLAGE

TRANSPORT

YIELD/RATE OF FLOW

QUALITY

 Bacteriological

PROTECTION

REMARKS

.....

.....

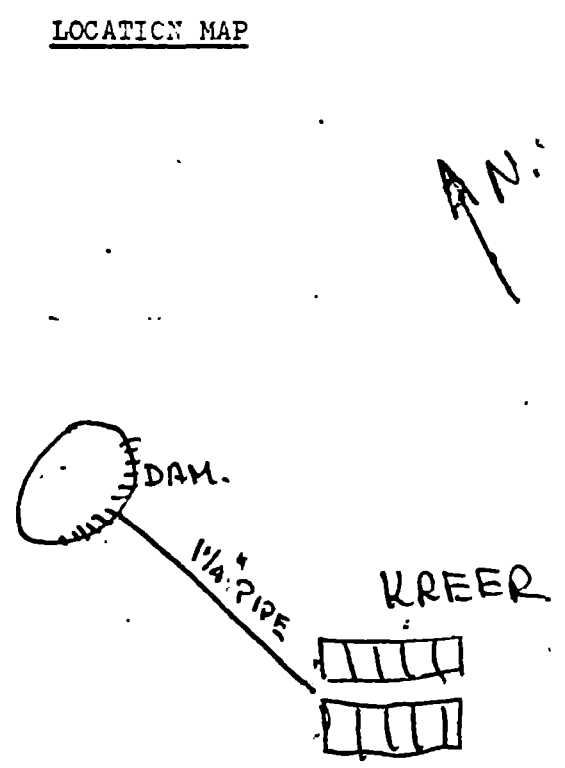

VILLAGE KREER RECOMMENDATIONS

TYPE OF RECOMMENDED SCHEME -- Pumped/Gravity/Well/Bore/Hydraulic
 Ram/Rainwater Catchment.

LOCATION OF NEW SUPPLY .. Village central.....

DISTANCE FROM VILLAGE Central.....

ACCESS Road.....

SITE KNOWN TO KABGI, Hutchison (A/D.O.).....

TYPE OF AQUIFER .. Natural spring in alluvium.....

DETAILS OF SCHEME ... Improvement of present scheme -- addition of screen
 .. at dam outlet and provision of concrete shower slab at outlet of ...
 .. pipeline in the village.....

MATERIALS REQUIRED See below.....

LABOUR REQUIRED Local.....

SUPERVISION Local.....

ESTIMATED COST (?) 20 plus labour.....

ALTERNATIVE SCHEME

PRIORITY . Second..... Signed .. J.R.L. Reed.... Date .. 2/10/66

LOCATION MAP

Film 1, photos 3 & 4.

Use existing scheme but replace gauge at the end of 4" clay pipe by the following.

- (i) Southern Cross Brass Strainer Mark BZ-E size 1 1/2" \$ 4-00
- (ii) Reducing Socket 1 1/2" x 1 1/4" G.I. - \$ 0-40
- (iii) 1 1/4" G.I. pipe about 5 ft. long - \$ 0-90
 threaded both ends. See sketch below
- (iv) Polythene to Make Iron End Connector 1 1/4" x 1 1/4" M.I. \$ 2-50
- (v) Socket G.I. 1 1/4" \$ 0-30

Total \$ 9-10

The pipe item (iii) to be made as per sketch
 Flange welded

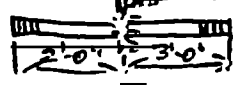

DAH.

APPENDIX J
Village Application Form

DEPARTMENT OF WESTERN HIGHLANDS
DIVISION OF HEALTH
P O BOX 129
MT HAGEN

RURAL WATER AND SANITATION APPLICATION FORM

PART 1 (To be filled by the applicants for project)

1. Name of Vilalge where project is to be constructed
_____ District _____
2. Type of Project _____
3. Number of People the project is to serve _____
4. Name of Person Incharge of the project _____
5. Estimate cost of project _____
6. Amount of Money you wish to pay _____
Cash or Passbook (No) _____
7. How was this money raised? _____

8. We agree to provide free labour, accommodation and transprot in this project.

Person In Charge

PART 2 (To be filled by Vilalge Leader or clerk of community government,
where project is to be constructed)

I the Village Leader or Clerk of _____ Community Government
endorse the application ofr this project.

Chairman/Clerk

PART 3 (to be completed by P.H.I., DM, DHI or Technical Officer)

this project is approved, disaproved.

Signed: _____

APPENDIX K
Project Proposal Fact Sheet

DEPARTMENT OF WESTERN HIGHLANDS
 DIVISION OF HEALTH
 P O BOX 129
 MT HAGEN

WATER SUPPLY AND SANITATION PROJECT PROPOSAL FACT SHEET

PROJECT DESCRIPTION

PROJECT NAME: _____

DETAILS:

IMPLEMENTATION:

POPULATION TO BE SERVED:

| <u>COST ESTIMATE:</u> | <u>*K</u> | <u>FUNDING BREAKDOWN</u> | <u>K</u> |
|-----------------------|-----------|--------------------------|----------|
| Materials | | Self help funds | |
| Labour | | Self help labour | |
| Transport | | Comm. Govt. | |
| P.T.A. Hire | | Other _____ | |
| Other _____ | | Govt. Crant | |
| Contingencies | | | _____ |
| <u>TOTAL:</u> | _____ | <u>TOTAL:</u> | _____ |

Project Design By:

Design checked and approved by: date

District Management Committee approved date

DMC Comments:

Kina for Kina Committee Approval date

Comment:

Committee Member Responsible

Implementing Officer

Expected completion date

APPENDIX L
Project Completion Certificate

DEPARTMENT OF WESTERN HIGHLANDS
DIVISION OF HEALTH
P O BOX 129
MT HAGEN

WATER AND SANITATION PROJECT COMPLETION CERTIFICATE

1. NAME OF THE PROJECT: _____
2. TYPE OF PROJECT: _____
3. POPULATION SERVED: _____
4. NAME OF THE VILLAGE: _____
5. NUMBER OF HOUSES: _____
6. TOTAL EXPENDITURE OF THE PROJECT: _____
7. MONTH PROJECT COMPLETED: _____
8. DISTRICT IN WHP: _____

THIS AUTHORITY CERTIFY THAT THE ABOVE MENTIONED WATER SUPPLY PROJECT FUNDED UNDER THE NPEP WATER SUPPLY AND SANITATION SECTORAL PROGRAMME IS TO DATE COMPLETED TO THE SATISFACTION OF OUR ENVIRONMENTAL HEALTH OFFICE HERE AT MT HAGEN.

DATE: _____

OFFICER IN CHARGE: _____

DESIGNATION: HEALTH INSPECTOR (WATER SUPPLY)

APPENDIX M

Financial Systems of the Government of Papua New Guinea

-

GOPNG Financial Systems

Financial Systems

The rural water supply and sanitation program operates within a structured financial system applicable to a wide variety of sectoral programs within government. After presenting an overview of this system, some specifics concerning its application to rural water and sanitation in the six provinces are described. An evaluation of the system is then presented including an assessment of how it acts as a constraint to effective program implementation.

Financial Systems Overview

Reports by Helminiak (5) and subsequently by Wheeler (22) describe the history and complexities of government planning and budgeting systems for the health activities in PNG. A much less complex picture exists however, for the water and sanitation program which receives its allocations through parliamentary votes sending funds earmarked specifically for rural water and sanitation ("301 vote") to the Environmental Health Sections of each of the Provincial Health Divisions. This "conditional" funding authority is made for functions such as the rural water supply and sanitation program which have been transferred to the provincial governments in accordance with the government's overall decentralization policy. As such, the funds may not be used for any other purpose and the provincial governments maintain complete control over their use.

Two other significant features of the PNG financial systems include the basis for accounting and budgeting (which is "line item") and the manner in which various expenditures are categorized, especially the policies relating to accounting for capital assets. The line item budgeting and accounting system is not amenable to planning, estimating and budgeting according to "projects;" consequently, any project accounting that is to be done must be done by the OICs for water and sanitation. It also falls short in that management techniques for planning, budgeting and control of expenditures based on performance measures can only be implemented through the creation of separate independent systems.

The accounting basis for project expenditures for rural water and sanitation is such that the costs of constructing water and sanitation schemes are not capitalized, except to the extent that a scheme incorporates a major piece of equipment such as a diesel engine or an expensive pump. Otherwise, all costs are charged off as expenses even though the intention is to create an asset of significant value having an economic life of, say five and hopefully more years.

There is, however, a consistency here with respect to the government's current policies toward community participation and responsibility. Upon completion, the water and sanitation schemes now become the assets of the villages, which have contributed labor and in some instances funds, toward development. Furthermore, government policy now emphasizes community responsibility for operating, protecting, and maintaining completed facilities. These policies, developed and refined during the early years of the first ADB loan and formally incorporated in the second loan agreement, tend to moot the issue of

asset accounting and provide the rationale for the absence of recurrent funding for operations and maintenance for completed systems.

One further comment concerns the manner in which the "301 vote" is used to aggregate funding for rural water supply and sanitation. Since initiation of the ADB funded project, the 301 sectoral category has been reserved exclusively for the ADB project. Prior levels of expenditure for the sector have been reallocated, often to the general environmental health activity. Expenditures for rural water supply and sanitation are also made in other categories, such as the National Development Fund account. Thus the full level of expenditure for rural water supply and sanitation is not captured and could only be determined through a separate system of accounting done within each health division. It would seem appropriate to attempt to recapture all expenses appropriately allocable to this sector. The scope of the ADB project is well defined and there should be no difficulty in keeping the reimbursable amounts separate from the nonreimbursable amounts.

Application of Financing Systems in the Rural Water Supply and Sanitation Program

There is an interfacing of financial systems with rural water supply and sanitation activities at several points in the process of project evolution, beginning with the planning phase and continuing on through project completion. The principal areas of impact of financing systems can be grouped into three main categories:

1. Financial planning, programming and budgeting
2. Budget approval and expenditure authorization
3. The expenditure process

PNG financial systems, as they are designed to operate in each of these categories are described in this section.

- Financial planning, programming and budgeting

Planning for new projects, such as the ADB Rural Health Services Project, begins in the agency involved, in this case the Department of Health. In preparation for project implementation, the responsible agency must prepare and submit an application for a new project under the National Public Expenditure Planning process. A complete description of the project is prepared along with all pertinent financial details including five year cash flow projections by line item. These are reviewed by the Department of National Planning and Development (DNP), the Department of Finance (DOF), and the Budget Priorities Committee (BPC) before submission to Parliament. The government's Medium Term Development Plan provides strategic guidelines concerning objectives and levels of investment in each of nine principal areas. The Rural Health Services Project including the rural water supply and sanitation elements, are categorized under "Rural Welfare" which is targeted to receive 10 percent of total government investment (although actual allocations in this category have been in excess of 16 percent).

Budget guidelines are issued in March and the provinces respond accordingly, submitting their requests through the DOH for review by DNP, DOF and the BPC. Provincial budget requests are developed by the operating units on worksheets for each line item.

- Budget approval and expenditure authorization

Parliament reviews and acts on the budget requests and the approved budget is transmitted to the provinces through the DNP/DOF and the DOH. The provinces are responsible for preparing quarterly cash flow estimates and for submitting them back through the foregoing chain of agencies. DOF processes and issues warrants to the provinces showing authorized quarterly allocations. After receipt of the warrants, the Bureau of Management Services in each province prepares Cash Fund Certificates which constitute official authorization to expend funds for each line item in each quarter. If delays are encountered, "precommitments" of up to 5 percent of the forthcoming allocation may be authorized by the provincial BMS manager. The quarterly cash flow expenditure plans may be modified by DOH at the request of a province as may be necessary.

- The expenditure process

Expenditure transactions begin with the preparation of a requisition by the operating level supervisor (e.g., the OIC for water supply), which must follow the prescribed purchasing regulations and be approved by the "financial delegate" in the Division of Health possessing an appropriate level of authority. The requisition is then transmitted to BMS where a Commitment Control Ledger card for the sectoral line item is checked to determine whether or not funds are available. If funds are not available, the transaction is disallowed. If funds are available in the amount required, an Integrated Local Purchase Order and Claim Form (ILPOC) is prepared for most items authorizing the commitment. Separate forms are used for items purchased from government stores and a General Expense Form is used to obtain checks for expense advances or reimbursements for workers, payments to the government motor pool (PTB), the Department of Works, the Post and Telecommunication Department and other agencies requiring cash payments rather than vouchers (vouchers require submission of invoices as a basis for payment).

Approved ILPOCs are taken to the supplier by the operating supervisor who completes his part of the transaction by receiving the items if available in stock or by ordering them if they are not available locally. The supplier submits the ILPOC form along with his invoice to BMS for payment. BMS checks the final invoice to BMS for payment. BMS checks the final invoice against the commitment control ledger card and makes adjustments as may be necessary to reflect differences between the amount committed and the final amount expended.

Experiences in Dealing with the System

The foregoing represents the normally expected flow of activities and transactions. In practice, however, things don't always happen as expected and numerous problems and difficulties have been experienced. Appendix A provides a summary of the actual experiences of rural water supply and sanitation staff in comparison with the government's prescribed procedures. Difficulties have been experienced with the financial systems in each of the six provinces on a rather consistent basis. The OICs for rural water and sanitation, in many cases have not been prepared to deal effectively with these situations. Examples of the difficulties encountered include:

- The basic financial planning, providing for K 60,000 per year per province, provided no transition period to allow the provincial organizations to mobilize, plan and efficiently undertake construction of water supply and sanitation systems.
- Annual budgeting amounts to no more than an exercise in determining how to distribute the K 60,000 among the various line items. While most OICs make an attempt at projecting program accomplishments, their forecasts tend to be unrealistic, and of no value in the budgeting process.
- Parliament normally acts upon the budget in November according to plan (1985/86 being a notable exception). However, the bureaucratic processing involved in achieving issuance of warrant authorization at the provincial level can result in major delays in gaining authorization to expend funds. These delays can be traced among other things, to a general lack of a sense of urgency among various concerned officials, including those at the provincial level and such mundane factors as delays in the postal system.
- When delays are encountered, the 5 percent precommitment, which is optional at the discretion of the local BMS manager, is of little value, being worth only about five days of expense requirements on a pro-rata basis.
- OICs seem unable in most cases to plan and schedule projects sufficiently in advance to be able to avoid delays and other difficulties with the procurement and financial systems, for example, by making large advance purchases or by scheduling their cash flow forecasts to provide for funding for materials and supplies weighed toward the early part of the year.
- The commitment control system does not work consistently, sometimes allowing expenditures to be made after the quarterly allocation funding has been exhausted. In other instances, "adjustments" have been massive as in one case wherein an initial commitment of K 150 was adjusted to K 1,750.
- Line item 1, salaries, is handled entirely at the DOF level and detailed information on that item is therefore not available at provincial level.

- Designation of expenditure items into the proper line item is very loosely controlled. Virtually all "301" expenditures in the Central Province during 1983 and 1984, for example, were charged to item 4, materials and supplies; in other examples, items properly chargeable to expenses were charged to capital and vice versa, capital items were charged under grants and subsidies (comprising in one year, nearly 1/3 of all expenses in item 4).
- There is no consistent check on the propriety of commitments, which has resulted in non-reimbursable expenditures such as a new office/storage yard (incidentally, charged to grants and subsidies line item) or inefficient use of funds such as excessive levels of compensation to villagers for lodging and board.
- This relatively undisciplined situation is somewhat pervasive and extends into BMS as well as in the environmental health units. In 1983 for example, BMS in West Sepik created commitment control cards under the "301" sector for four functions that are not authorized under that vote including health, TB & Leprosy, Health Nutrition, Dental Health and PHD-STD.

These situations have been identified and action taken to prevent or at least to attempt to prevent, their recurrence. Under present circumstances, however, it must be presumed that there are many more such problems in the making, in effect just "waiting to happen."

Application of Financial Systems to Rural Water Supply and Sanitation Program
Experiences of Six Provinces in Papua New Guinea

| <u>Principal Elements of Financial Systems</u> | <u>Prescribed Procedures and mode of system operation</u> | <u>Experiences in the six provinces with the application of financial systems to rural water supply and sanitation</u> |
|--|--|--|
| Financial planning, programming and budgeting | <p>NPEP submissions for new projects. Medium Term Development Plan provides guidance on investment strategies. The rural welfare category (which includes the rural water and sanitation program) is targeted at 10 percent of total government investment.</p> <p>Budget guidelines issued in March, provinces respond and submit requests through DOH for review by DNP (formerly NPO) and the Budget Priorities Committee</p> <p>Budget requests developed within provinces on line item basis for each sectoral program. Worksheets prepared at operating level.</p> | <p>Basic financial planning done at outset of project; K60,000/yr./province is fixed.</p> <p>Level of expenditures for rural welfare programs has been in excess of 16%.</p> <p>Budget requests for rural water supply and sanitation are basically an exercise in determining how to divide the K60,000 among the applicable line items. Worksheet preparation varies among the six provinces with the OICs developing them in some cases but more frequently the estimates are prepared at higher levels (e.g., PHI or PHEO).</p> <p>Most OIC attempt to project program accomplishments in terms of projects to be completed including estimated costs. However, the general level of understanding of costing factors and ability to estimate overall costs results in generally meaningless forecasts.</p> <p>Since the 301 sectoral category is limited to only those expenditures included in the ADB project, other ongoing rural water and sanitation expenditures are charged under the general environmental category; thus total expenditures in the sector are not captured/recorded.</p> |
| Budget approval and expenditure authorization | <p>Parliament reviews and acts on budget. Approved budget transmitted to provinces through DNPC/DOF and DOH. Cash flow estimates (quarterly) prepared by provinces and submitted through DOH to DOF, copy to DNP.</p> <p>After DNP approval, DOF processes and issues warrants to provinces showing authorized quarterly allocations.</p> | <p>Although Parliament normally gets on the budget in November or early December, (1985/86 being notable exception) the extensive bureaucratic processing involved can result in major delays in receiving expenditure authorization at the provincial level. (e.g., (1) cash flow estimates must all be received (from all provinces) before warrants issued (2) sense of urgency lacking among various concerned offices including provinces, (3) delays in postal system (internal & P&T) in</p> |

Principal Elements of
Financial Systems

Prescribed Procedures and mode of
mode of system operation

Experiences in the six provinces with the application
of financial systems to rural water supply and sanitation

BMS units in provinces prepare cash fund Certificates which constitute official authorization to expend funds for each line item, each quarter. If delays are encountered "pre-commitments" of up to five percent of the forthcoming allocation may be authorized by the provincial BMS manager.
Quarterly expenditure plans can be modified by DOF at province's request.

forwarding warrants, BMSM may insist on receipt of document.)
Thus OICs may be delayed in ordering materials, then wait again for delivery and may have to restrict travel, etc.
In some cases no quarterly allocation is made or an obviously erroneous one is issued, unnecessarily re-structure origin _____. Subsequently, excessive fund availability at year-end can create pressure to expand and associated inefficient fund utilization — alternatively, funds lapse off.
The five percent precommitment, which is discretionary on part of BMS manager, is only equivalent to about five days expenditures and therefore of marginal value.
OICs in many cases unable to deal effectively with these situations and receive (or fail to seek) support from superiors.

The expenditure
process

Requisitions are prepared by the operations level supervisor which contain all necessary information procurement regulations prescribe purchases be made as follows:
- < K50, any supplier without quotation
- K51-K500 - three verbal quotations
- K501-K2,500 - three written quotations
- K2,501 tenders by tender board (except government agencies)
A designated financial delegate in the requisitioning organization possessing, an appropriate level of authority must sign the requisition.
The requisition is reviewed at BMS where the Commitment Control Ledger cards are checked to see if funds are available in

OICs seem generally unable to plan ahead sufficiently to be able to avoid difficulties with the financial system
- lack of comprehensive survey data to use as baseline (although under preparation or being planned)
- large advance purchases to maintain stocks of commonly required materials
- Work the system to (1) get larger percent of item 4 Funded in first quarter, f (2) get proper balance of funding in various items (thru transfers if required)
- In some cases to avoid charges to 301 budget for other uses
Some complaints regarding financial delegation, but should be no problem if...
Commitment controls sometimes work, other times not
- "adjustments" may be massive (up or down) and result in uncertainty regarding Fin. position

Principal Elements of
Financial Systems

Prescribed Procedures and mode of
mode of system operation

Experiences in the six provinces with the application
of financial systems to rural water supply and sanitation

the quarterly funding to date. If not, the transaction is disallowed. If so, an Integrated Local purchase Order and Claim Form (ILPOC) is prepared authorizing the commitment (for most items a separate form is used for requests from government stores and a General Expense Form is used to obtain checks for expense advances/reimbursement or payments to PTB, Works or Post and Telecommunications)

The approved ILPOC is then taken to the supplier and the materials are received/ordered. The supplier then submits the ILPOC to BMS for payment. Adjustments for variations between the estimated commitment and actual amount are made on the ledger cards by BMS

Transfers from one line item to another may be made by DOF based on quarterly reviews/requests from provinces. Transfers are made of individual expenditure items from one line item to another by DOF on recommendation by auditors.

- sometimes controls enforced only after large overexpend
 - item 1 salaries of PSC positions is handled by DOF. Any bookkeeping thereon must be done informally; accounting at DOF is only by general category (e.g., rural health) so sectoral breakdown is not available
 - proper designation of expend category is very loose; e.g., Central Province — all of 1984 budget and most of 1983 charged to item 4, expense items charged to capital, capital; then charged to (4) supplies or (6) grants and subsidies, air/marine charters to materials and supplies, etc.
 - major commitments for nonreimbursable items (e.g., new office/yard in W. Sepik)
 - excessive payments for lodging/subsistence in bush
 - charging of non 301 items to 301
- Many such instances have been corrected, but situation is such that at any given time there are likely to be one or more fund utilization problems developing ("disasters waiting to happen")

APPENDIX N

Department of Works
Oliguti Training Syllabus



DEPARTMENT OF WORKS AND SUPPLY E.H.P

TELEPHONE: 72 1377/72 1078/72 1313
TELEGRAMS:
TELEX NE 72615

P O BOX 879
GOROKA EHP
PAPUA NEW GUINEA

| | | | | |
|---|---------------------------|---|-----------------------|-----------------|
| ┌ | | ┐ | <i>Date</i> | 9 April 1986 |
| | Local Government Engineer | | <i>Our Reference</i> | |
| | Department of Works | | <i>Action Officer</i> | P T AHMAT |
| | P O Box 425 | | <i>Designation</i> | OIC Oliguti T/C |
| | MADANG | | | |
| └ | | ┘ | <i>Your Reference</i> | |
| | | | <i>Date</i> | |

**TRAINING SYLLABUS
OLIGUTI TRAINING CENTRE**

... Please find details of our Training Syllabus for your attention.

Training of subjects is such that 80% is on the job PRACTICAL lessons, etc and 20% is classroom lectures, etc.

Revision tests of all given subjects is made every month prior to, MID-TERM EXAMS and FINAL EXAMS.

Assortment of project training is normally implemented more than once so as to insure all participants obtain sufficient knowledge of these projects.

P T AHMAT
Principal - Senior Instructor

TRAINING SYLLABUS

BASIC RURAL WATER SUPPLY COURSE

(1) RETICULATED SYSTEM (GRAVITY FEED)

- a) Introduction
- b) Lesson and notes on subject
- c) Health aspects of water supplies
- d) Surveying aspects of the project
- e) Reading of plans - simplifying
- f) Pipe selection and pressure ratings
- g) Practical lessons on, tools, fittings, threading, etc.
- h) Construction of small dams
- i) On the job instructions of the overall construction of the project.

(2) SPRING CATCHMENT SYSTEM (LOW YIELD)

- a) Introduction
- b) Lessons and notes on subject
- c) Use of tools, fittings, threading, etc.
- d) Locations and trenching of spring area
- e) Health aspects of water supplies
- f) Surveying aspects of project
- g) Yield calculation
- h) Construction of spring, intake box
- i) On the job instruction of the overall construction of the project.

(3) SANITARY SHALLOW WATER WELL

- a) Introduction
- b) Lesson and notes on subject
- c) Health aspects of water supply
- d) Siting of proposed well area
- e) Use of tools, fittings and equipments
- f) Safety measures
- g) Estimating, Depth, Volume and field of water
- h) Use of the concrete well liner STEEL mould
- i) Making of concrete well liners
- j) General excavation of the well
- k) Removal of concrete well liners
- l) Maintenance and cleaning of well
- m) Maintenance and care of Pump
- n) On the job instruction of the overall construction of the project.

(4) HYDRAULIC RAM SYSTEM

- a) Introduction
- b) Lesson and notes on subject
- c) Health aspects of water supply
- d) Surveying aspects of project
- e) Reading of plans - simplifying
- f) Operational aspects of the ram
- g) Use of tools, fittings,
- h) On the job instructions of the overall construction of the project.

(5) PNG BLAIR PUMP

- a) Introduction
- b) Lesson and notes on subject
- c) Use of tools, fittings and materials
- d) Health aspects of bore water
- e) Care and use of pump
- f) Making of the valves (2)
- g) Assembly and making of the pump body
- h) Use of the augering tool
- i) Excavation of the bore
- j) Overall installation of the pump
- k) Overall construction of the concrete pump apron

(6) GALVANISED WATER STORAGE TANK

- a) Introduction
- b) Lesson and notes on the subject
- c) Use of tools, fittings and materials
- d) Instructions on the use of the soldering apparatus
- e) Practical instruction of grooving, etc, of joints
- f) Practical instruction on riveting of tank rings
- g) Instruction on the overall assembling of tank body
- h) Practical instruction on soldering
- i) Practical instruction on, downpipes, guttering, etc.
- j) Safety Measures
- k) On the job instruction of the overall construction of the tank.

(7) FERROCEMENT WATER STORAGE TANK 45001-90001
(REPAIR OF OLD G.I. TANKS)

- a) Introduction
- b) Lesson and notes on the subject
- c) Use of tools, fittings and materials
- d) Practical instructions on, preparation, screening and washing of fine river or sea sand
- e) Preparations of the old tank body
- f) Practical instructions on the tying of screen mesh
- g) Practical instructions on the construction of the concrete tank base.
- h) Practical instructions on the mixing and use of MORTAR
- i) Practical instructions on the application of mortar on to the tank body
- j) Practical instructions on the repairs to leaks
- k) Practical instructions on the making of the Tank cover
- l) On the job instructions of the overall construction of the tank.

(8) BASIC MANAGEMENT

Introduction

Lectures and notes on the following:-

- a) Management
- b) The Supervisor
- c) Definitions of Leadership
- d) Some qualities necessary for leadership
- e) Delegation
- f) Responsibility to subordinates
- g) What the worker expects of a foreman or supervisor
- h) How to give instructions
- i) Common problems in communication
- j) Decision making
- k) How to solve problems
- l) Using facts to solve problems
- m) Planning personal time

(9) FOREMANSHIP AND SAFETY PRECAUTIONS

Introduction

Lectures and notes on the following:-

- a) Duties of a Foreman
- b) Qualities of a Foreman
- c) Qualification of a Foreman
- d) Work habits and attitudes of a Foreman
- e) Safety Precautions
- f) Accident Prevention
- g) The basic steps to accident prevention
- h) Hazards
- i) Job Safety

(10) METRIC SYSTEM

Introduction

Lectures and notes on the following:-

- a) Weights, Measures and volume.
- b) Units and Decimal points
- c) Practical lessons
- d) Theory and practical tests (Revisions).

(11) IN ADDITION

- a) Basic setting with the use of levels
- b) Proper screening and washing of, gravel, sand and aggregates
- c) Selection of aggregate sizes
- d) Proper mixing of concrete
- e) Basic carpentering
- f) Care and maintenance of, tools, equipment, etc.
- g) Basic drawings of assorted project plans
- h) Basic vegetable gardening.

PRACTICAL & THEORY TRAINING

Actual working days spent on training

(1) RETICULATION SYSTEM

| | | |
|-----------------------------|---|----------------|
| Classroom lectures, etc. | = | 3 days |
| Surveying aspects, etc. | = | 2 days |
| Overall construction period | = | <u>15 days</u> |
| | | <u>20 days</u> |

20 days x 8 hrs/day = 160 man hours.

(2) HYDRAULIC RAM SYSTEM

| | | |
|-----------------------------|---|----------------|
| Classroom lectures, etc. | = | 3 days |
| Surveying aspects, etc. | = | 2 days |
| Overall construction period | = | <u>10 days</u> |
| | | <u>15 days</u> |

15 days x 8 hrs/day = 120 man hours.

(3) SANITARY SHALLOW WATER WELL

| | | |
|-----------------------------|---|----------------|
| Classroom lectures, etc. | = | 3 days |
| Construction of well liners | = | 2 days |
| Overall excavation of well | = | <u>10 days</u> |
| | | <u>15 days</u> |

15 days x 8 hrs/day = 120 man hours.

(4) BLAIR PUMP

| | | |
|--|---|----------------|
| Classroom lectures, etc. | = | 2 days |
| Assembly of Pump, etc. | = | 1½ days |
| Overall installation of | = | 1½ days |
| Pump and Concrete apron augering, etc. | = | <u>5 days</u> |
| | | <u>10 days</u> |

10 days x 8 hrs/day = 80 man hours.

(5) GALVANISED WATER STORAGE TANK

| | | |
|---|---|----------------|
| Classroom lectures, etc. | = | 2 days |
| Practical lessons on, Tools, etc. | = | 1 days |
| Practical lessons on, D/Pipes, gutterings | = | 2 days |
| Overall construction of tank | = | <u>5 days</u> |
| | | <u>10 days</u> |

10 days x 8 hrs/day = 80 man hours.

(6) FERROCEMENT W/S TANK - 4500-90001
(Repairs to Old G.I. Tanks.)

| | | |
|-------------------------------|---|----------------|
| Classroom lectures, etc. | = | 1 day |
| Screening and washing of sand | = | 3 days |
| Site preparation | = | 1 day |
| Tank preparation | = | 1 day |
| Overall construction of Tank | = | <u>4 days</u> |
| | | <u>10 days</u> |

10 days x 8 hrs/day = 80 man hours.

(7) SPRING CATCHMENT SYSTEM

| | | |
|---------------------------------|---|----------------|
| Classroom lectures, etc. | = | 2 days |
| Survey aspects, etc. | = | 2 days |
| Overall construction of project | = | <u>10 days</u> |
| | | <u>14 days</u> |

14 days x 8 hrs/day = 112 man hours.

THEORY LESSONS

A) MANAGEMENT

Classroom lectures, etc. = 2 days

B) METRIC SYSTEM

Classroom lectures, etc. = 5 days

C) FOREMANSHIP & SAFETY PRECAUTIONS

Classroom lectures and lessons = 3 days
11 days

11 days x 8 hrs/day = 88 man hours.

SUMMARY

March - December = 206 working days.

| | | |
|--|---|-----------------|
| Public holidays = 10 days |) | 115 W/Days. |
| Actual Training period = 105 working days) | | |
| Expendible days | = | <u>91 days</u> |
| | | <u>206 days</u> |



