



3. Direct pit toilets





3.1 VENTILATED SINGLE PIT TOILET



Applicability

- Suitable where people use solid/ hard materials for anal cleansing. These can be directly deposited into the toilet pit.
- Suitable for locations where there is scarcity of water or where the water supply is not always dependable.
- Suitable where the ground is easy to excavate and where there is no high water-table, water-logging, or flooding.
- Suitable where there is space to excavate a new pit and move the superstructure when the original pit becomes full.
- Suitable for remote areas where transportation of imported materials is difficult and costly.
- Cheap and easy to build with local materials only.

Construction

1. **Pit cover-slab/ floor:** This can be made out of round timber ballies with fine earth on top or RCC slab using bamboo (refer page 46) or steel reinforcement. The floor should be smoothly finished and made impervious to water and urine penetration.
2. **Walls:** Walls can be of ekra on 3"x3" ballies/ battens with mud/ cement plaster. Stone walling built up to 1' above ground- level will help avoid rotting of timber.
3. **Roof:** This can be made from wood shingles, bamboo matting, CGI sheets, or old bitumen sheets over timber/ ballies rafter and purlins (size of rafter is 3"x4" and purlins 2"x3"). The roof should be firmly secured to prevent wind damage.
4. **Vent-pipe:** The vent-pipe can be PVC, HDPE, timber planks or large diameter bamboo. The top of the vent-pipe must be fitted with a fly-screen and must also allow sunlight to enter the pipe (refer page 45 for additional details).
5. **Superstructure:** The recommended superstructure is the G-shaped design (refer page 48) with an open entrance.
6. **The pit** can be lined with dry hammer-dressed stones 1'4" thick to prevent rat nuisance and collapse of the earth. The minimum depth of the pit should be 4'. (refer page 47)



Toilet location, proper use and hygiene

1. This toilet can be built closer to the house than the traditional basic pit latrine.
2. The location should be chosen considering wind and sunlight direction.
3. The toilet should be located at a minimum distance of 15 meters from any type of water source.
4. For the air to be able to flow, use of a drop-hole cover is not recommended during day time.
5. Once a week, sweep, wash and clean the toilet floor (preferably using disinfectant), and clean the toilet surrounding area.
6. Once a month, clean the walls, door and ceiling.
7. Once every six months check the fly-screen on top of the vent-pipe and check the pipe is not obstructed.
8. Repairs should be carried out immediately.
9. The pit must not be used for garbage disposal.

Always leave the toilet the way you would like to find it - clean, tidy and ready to use.

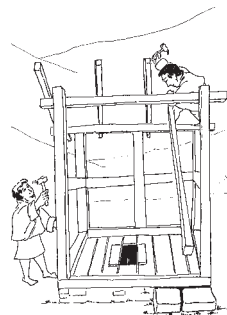

Approximate material estimate			
Sl. No.	Particular	Qty	Unit
1	Pipe 4" diameter (10' long)	1	No
2	Sliding bolt	1	No
3	Tower bolt	1	No
4	Handle	2	No
5	Nails	3	Kg
6	Hinges	3	No
7	Timber	15	cft
8	Stone	70	cft
9	Skilled labour	10	work-day
10	Unskilled labour	15	work-day

Approximate minimum cost excluding local materials and labour = Nu. 1000/-





3.1 Ventilated single pit toilet

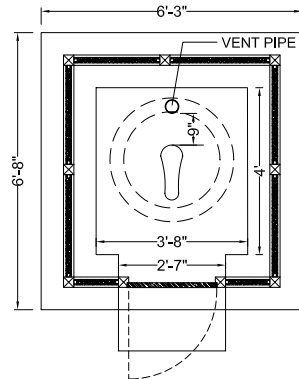

ALTERNATIVE PLAN

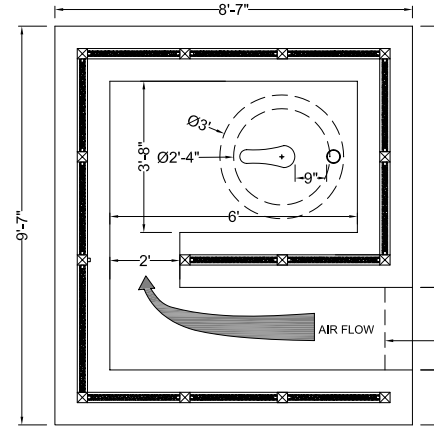

RECOMMENDED PLAN

SEMI CLOSED ENTRANCE, e.g. CLOTH etc, BUT ALLOWING AIR TO FLOW TO THE TOILET.

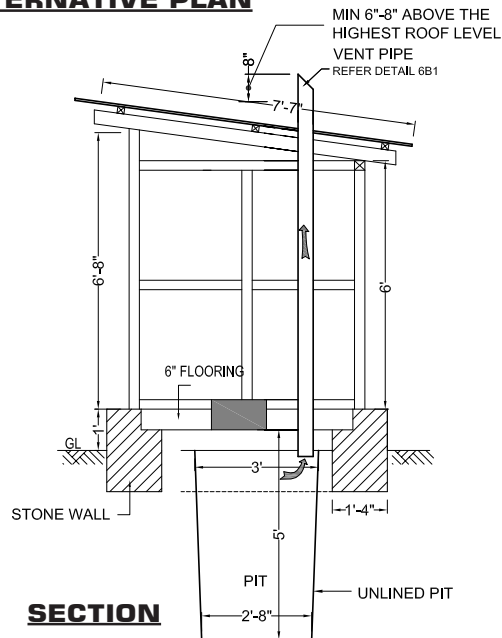

SECTION

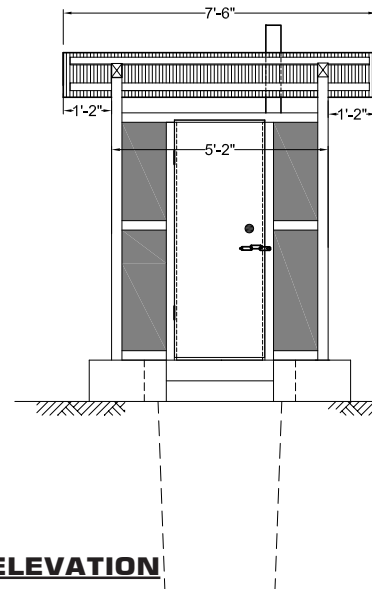

FRONT ELEVATION

Scale: Not to scale



3.2 VENTILATED DOUBLE PIT TOILET

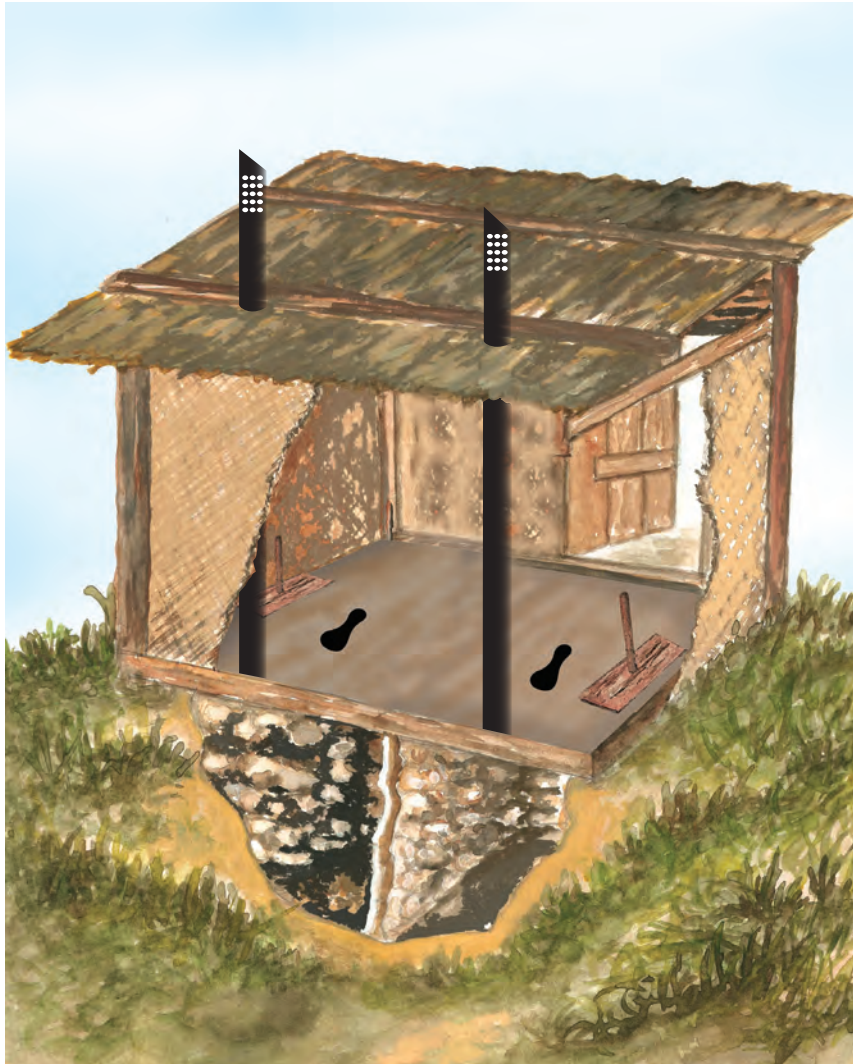

Applicability – same as 3.1

- The double pits make this design a more permanent toilet than the single ventilated pit toilet.
- When one pit becomes full it is closed and the other pit is put into use. When the second pit becomes full it is closed and the first is emptied and put back into use. After remaining in the closed pit for at least 1 year, the decomposed contents are safe to use as a plant fertiliser if desired. The alternating use of the two pits avoids the need for excavating new pits.

Construction

1. **Pit cover-slab/ floor:** This can be made out of round timber ballies with fine earth on top or RCC slab using bamboo or steel reinforcement. The floor should be smoothly finished and made impervious to water and urine penetration.
2. **Walls:** Walls can be of ekra on 3"x3" ballies/ battens with mud/ cement plaster. Stone walling built up to 1' above ground- level will help avoid rotting of timber.
3. **Roof:** This can be made from wooden shingles, bamboo matting, CGI sheets, or old bitumen sheets over timber/ ballies rafter and purlins (size of rafter is 3"x4" and purlins 2"x3"). The roof should be firmly secured to prevent wind damage.
4. **Vent-pipe:** The vent-pipe can be PVC, HDPE, timber planks or large diameter bamboo. The top of the vent-pipe must be fitted with a fly-screen and must also allow sunlight to enter the pipe (refer page 45).
5. **Superstructure:** The recommended superstructure is the G-shaped design (refer page 48) with an open entrance.
6. **The pits** can be lined with dry hammer-dressed stones 1'4" thick to prevent rat nuisance and collapse of the earth. Cement mortar should be used for the wall between the pits to prevent seepage between the pits.



Toilet location, proper use and hygiene

1. This toilet can be built closer to the house than the traditional basic pit latrine.
2. The location should be chosen considering wind and sunlight direction
3. The toilet should be located at a minimum distance of 15 meters from any type of water source.
4. For the air to be able to flow, use of a drop-hole cover is not recommended during day time.
5. Once a week, sweep, wash and clean the toilet floor (preferably using disinfectant), and clean the toilet surrounding area.
6. Once a month, clean the walls, door and ceiling.
7. Once every six months check the fly-screen on top of the vent-pipe and check the pipe is not obstructed.
8. Repairs should be carried out immediately.
9. The pits must not be used for garbage disposal.

Always wash your hands with soap after using the toilet.



Approximate material estimate			
Sl. No.	Particular	Qty	Unit
1	Cement (50 Kg bags)	3	bags
2	Pipe 4" diameter (10' long)	2	No
3	Sliding bolt	1	No
4	Tower bolt	2	No
5	Handle	2	No
6	Nails	6	Kgs
7	Hinges	3	No
8	Timber	25	cft
9	Stone	140	cft
10	Sand	15	cft
11	Skilled labour	15	work-day
12	Unskilled labour	25	work-day

Approximate minimum cost excluding local materials and labour = Nu. 3000/-

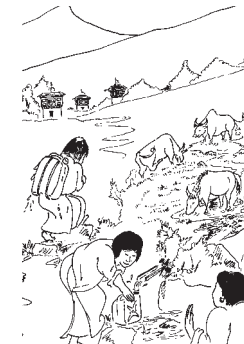



3.2 Ventilated double pit toilet

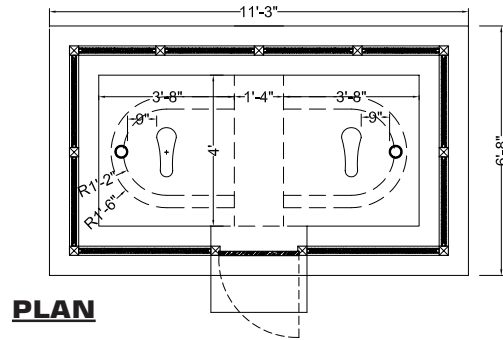

PLAN

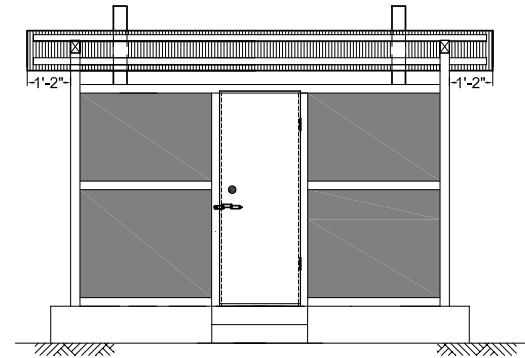

FRONT ELEVATION

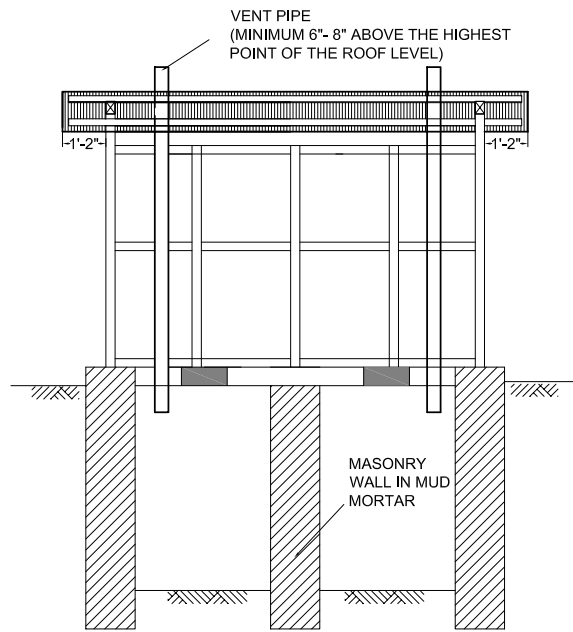

SECTION

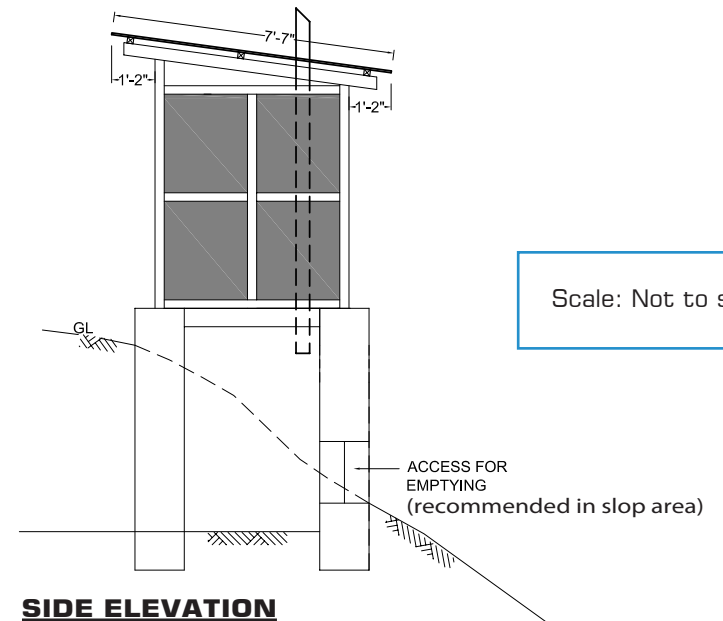

SIDE ELEVATION

Scale: Not to scale