

# **GUIDELINES ON APPROPRIATE TECHNOLOGIES FOR WATER SUPPLY AND SANITATION IN DEVELOPING COMMUNITIES**

**LA Pearson • J Bhagwan • W Kariuki • W Banda**

**WRC Report No. 520/1/01**

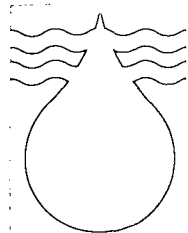

Water Research Commission 

201-17515

LIBRARY IRC  
PO Box 93190, 2509 AD THE HAGUE  
Tel.: +31 70 30 689 80  
Fax: +31 70 35 899 64  
BARCODE: 17 515  
LO:

#### **Disclaimer**

This report emanates from a project financed by the Water Research Commission (WRC) and is approved for publication. Approval does not signify that the contents necessarily reflect the views and policies of the WRC or the members of the project steering committee, nor does mention of trade names or commercial products constitute endorsement or recommendation for use.

#### **Vrywaring**

Hierdie verslag spruit voort uit 'n navorsingsprojek wat deur die Waternavorsingskommissie (WNK) gefinansier is en goedgekeur is vir publikasie. Goedkeuring beteken nie noodwendig dat die inhoud die siening en beleid van die WNK of die lede van die projek-loodskomitee weerspieël nie, of dat melding van handelsname of -ware deur die WNK vir gebruik goedgekeur of aanbeveel word nie.

**Guidelines on appropriate technologies  
for water supply and sanitation  
in developing communities**

**Report to the Water Research Commission**

**by**

**L.A. Pearson, J Bhagwan, W. Kariuki, W. Banda**

**Division of Water, Environment and Forestry Technology  
CSIR**

**WRC Report No. 520/1/01**

**ISBN No.: 1 86845 840 7**

**January 2002**

# EXECUTIVE SUMMARY

## 1. BACKGROUND AND MOTIVATION

In the context of the development focus of the RDP programme, particularly towards rural and peri-urban areas of South Africa, there arose a need for information on development options and approaches, particularly with respect to water supply and sanitation. The CSIR and various organisations had been producing guidelines which were often requested by various role players, and there was a need to expand the availability of guideline documents to cater for various role players.

An additional motivation for the project was that a number of new role players were entering the market and there was a need to orientate them to the various non-conventional technologies and approaches that are relevant to developing communities.

In 1993 the Water Research Commission subsequently approved the commencement of the project for the compilation of additional guideline documents as set out in the proposal of the CSIR.

## 2. OBJECTIVES

The objectives of the project as specified in the contract are:

- \* to provide information to development agencies on appropriate technologies applicable to developing communities;
- \* to update existing guidelines on appropriate technologies which could be applicable in Southern Africa;
- \* to provide concise, yet clear and easy to read materials for the training of rural development officers and village water supply caretakers and managers;
- \* from the literature and through selected field evaluations, to reassess the potential of various technologies and community development approaches in the provision of water supply and sanitation facilities;
- \* to support the present and future increased emphases on social development programmes by providing information on technologies and approaches which work in the developing areas.

## 3. RESULTS AND CONCLUSIONS

A total of six documents were completed as fulfilment of this project, while 3 others were shelved or rejected by the steering committee as being not appropriate or required due to the existence of other documents which met this need. Of the six documents completed,



almost all have been modified and changed during the project period to adapt to the rapid changes in the development environment and the development of new technologies and approaches.

Within the rural development context, the new emphasis on sanitation and health and hygiene awareness has placed a significant demand and need for the documents dealing with these aspects.

The researchers and authors of the documents have realised that the compilation of technical guides is actually exceptionally demanding in terms of time, focussed writing and editing, and presentation. The development of guidelines requires dedicated and focussed time set aside to achieve acceptable results. The researchers found this often difficult within the realms of the demanding work environment they found themselves. Consequently they would recommend that future guideline development be approached cautiously, ensuring that the authors be given sufficient time and resources to be able to undertake the task within a fixed but dedicated time period. Authors of guidelines should also have the necessary writing skills with a good knowledge of the technology and technology transfer principles.

#### **4. ACHIEVEMENT OF OBJECTIVES**

The extent to which the contract objectives have been met may be stated as being partial. Many of the objectives have been achieved, but in some cases the objectives were not fully realisable.

The project has achieved the objectives of providing information on appropriate technologies that can be applied in the South African context where such information was not previously readily available. In addition the guidelines have attempted to place a certain emphasis on the approach and methodology for implementation which is appropriate in the rural development sector. This meets the objectives of increased emphasis on the requirements of social development programmes as opposed to purely technical projects.

The project did not fully achieve the objective of providing materials for training of rural development officers and village water supply caretakers and managers. Only in terms of sanitation and pumping was the material compiled in a way that can be used for training of particularly village level personnel. All the other guidelines can be used by rural development officers, including in training courses for new officers.

The following documents were completed:

*i) Ground water exploration, use and conservation*

This guideline document has been compiled particularly for implementing agents and project agents. It describes the occurrence of groundwater in nature and the approaches and methodologies applied to extract ground water as a water supply. In addition the guideline addresses the requirements for good care of boreholes and the proper management of the groundwater aquifer to avoid over-exploitation. An operator manual was not appropriate for this guideline since each

borehole installation is unique and requires the project agent to compile a specific manual based on the installation. A generic manual would have to cover too many alternatives to be of general use. However certain sections of the manual can be readily adopted for inclusion in the operator manual of specific installations.

**ii) *Primary health care through improved water supply, sanitation and community education.***

This guideline document has also been compiled with the user being the implementing agent or the project agent. However it is easily usable as a training tool by community health workers.

The guideline document describes the health impacts of water supply and sanitation, including disease transmission routes. This is followed by a section on educational techniques and programmes in the area of primary health care. The main section of the document deals with the planning and implementation of a targeted health and hygiene education programme in a community.

A number of elements of the manual are readily applicable for training of community development officers and village health workers. In terms of health and hygiene education, a separate manual is not required for these personnel.

As part of the development of this guideline document, an interactive "story telling" tool was compiled for use in hygiene education programmes. Dr Roy Jobson who has also been involved in the Soul City programmes wrote this tool.

**iii) *Springs and spring protection***

This guideline document was changed by the steering committee to be specifically for development agencies. It was written at a high level and was therefore not easily usable by community development officers and village management committees.

The document deals with the occurrence of ground water at the near surface, and the occurrence of springs. The different types of springs are dealt with extensively, and the approach to be adopted in selecting a spring for use as a water source for a community water supply. The quality of spring water is addressed, including steps that can be taken to improve the water quality without the need for treatment.

The different options for the development and protection of the spring source is described, and the ongoing maintenance requirements are addressed.

It was agreed by the steering committee that the community level manual should not be compiled as part of this project as one is already available. This manual, with a video, obtainable from the CSIR, is entitled "The protection of a natural spring". It can be ordered from the Environmentek library.

iv) ***Small scale desalination***

Desalination is not a general need in rural water supply schemes. However there are a few areas in South Africa where almost all sources of water are saline or carry a salt that can be harmful to the health of the users. This includes areas using groundwater that has a high fluoride content, a high nitrate content, or a high salinity.

The guideline document is written specifically for development agencies having to deal with such situations. The guideline document describes the different types of problem salinity found in water, and the different options for treatment of these waters. These range from the relatively sophisticated technologies of reverse osmosis and electro dialysis, to the age-old technique of solar distillation. A method for the selection of an appropriate technique is described, including a method for costing.

The guideline can be used as a training manual for those involved with addressing such problems. However it is not written as an operators manual. The suppliers of equipment will always supply an operators manual with the equipment, as each installation is unique.

v) ***Pumps and pumping systems (modified topic from original proposal)***

In the original proposal this guideline document was only to address handpumps. At an early steering committee meeting the chairman requested that this be changed to address all pumps that may be used in rural water supply projects. Although this required considerable additional time and resources, the merit of the decision was readily appreciated.

The guideline manual has been written mainly for development agencies, but contains many sections that can be used directly for the training of community development officers and village committees and pump operators. One of the appendices is specifically for the operation of the different pump types.

The document describes the different types of pumps, the different energy sources that can be employed for pumping, and the requirements of different pump installations. The methodology for selecting a pump for a particular application is described, and the operation and monitoring programme for different pumps is proposed.

vi) ***Sanitation for rural communities***

This guideline document has been specifically written for community committees involved in the initiation or implementation of a sanitation programme. A second document for development agencies was compiled and presented to the steering committee, but the steering committee took a decision not to publish it because there were sufficient books and guidelines on sanitation already available for development agencies. A decision was taken not to publish this guideline document.

## **Documents not completed or shelved were:**

### ***Water clarification***

It was proposed and accepted by the steering committee that there exists sufficient good literature in a suitable format on this topic. This includes the recent publication of the WRC "Water Purification Works Design" edited by F.A. van Duuren.

### ***Surface Water Abstraction***

It was proposed and accepted by the steering committee that sufficient suitable literature is available. This includes the book by Hofkes, E.H. (ed.) 1981. "Small community water supplies. Technology of small water supply systems in developing countries". The Hague: IRC", an earlier WRC publication on "The cost effectiveness of rural water supply and sanitation programmes", and the book by Mr R Stevens on "Rural Water Supplies".

### ***Storage and distribution***

It was proposed and accepted by the steering committee that sufficient suitable literature is available. This includes a handbook and video published by Environmentek, CSIR on "the construction of a small ferro-cement water tank".

While it is regrettable that not all the documents could be completed, it was appreciated that the additional requirements of certain documents (e.g. the pumps and pumping guideline) meant that additional time was required on these documents. In addition it was appreciated that new documents should not be compiled where existing document adequately address the relevant aspects for community development programmes.

## **5. Recommendations**

In order to disseminate the guideline documents to potential users, it is recommended that a strategy for their promotion and distribution be developed. Existing WRC procedures may be adopted, together with promotion through various national and regional bodies (e.g. NaSCO).

In terms of future development of guidelines, Mr Ian Palmer of the Palmer development Group has proposed a draft matrix. This matrix looks at the need for guidelines within the water sector, including the types of institutions involved along one axis, and the type of activities undertaken along the other axis. It is recommended that future development of guidelines fit in with this matrix, and that priority be given to areas of greatest need.

In parallel with this proposed programme, it would be useful to assess the specific information needs of the different organisations involved in the sector, and to assess the value of these and other guidelines already in use.

## ACKNOWLEDGEMENTS

The guideline documents and reports emanated from a project funded by the Water Research Commission and entitled:

“Guidelines on appropriate technologies for water supply and sanitation in developing communities”

The Steering Committee responsible for this project consisted of the following persons:

Dr NP Mjoli	Water Research Commission (Chairperson)
Mr HC Chapman	Water Research Commission (previous chairperson)
Mr J Bhagwan	Water Research Commission
Mr B Jackson	Development Bank of Southern Africa
Mr DG Hazelton	Environmentek, CSIR
Mr I Palmer	Palmer Development Group
Mr I Ngwenya	Umgeni Water
Ms U Wium	Water Research Commission (Committee Secretary)

The financing of the project by the Water Research Commission and the contribution of the members of the Steering Committee is gratefully acknowledged.

This project also had the cooperation and inputs of a number of other individuals, for who the project team would like to record their sincere thanks. These include:

Dr Roy Jobson	Alexander Clinic
Mr Phil Dawson	Consultant
Mr Wonder Banda	previously of Environmentek, CSIR
Mr Wainaina Kariuki	previously of Environmentek, CSIR
Mr Jay Bhagwan	previously of Environmentek, CSIR
Mr Derek Hazelton	previously of Environmentek, CSIR

## **TABLE OF CONTENTS**

- I. EXECUTIVE SUMMARY
- II. GROUND WATER EXPLORATION, USE AND CONSERVATION
- III. PRIMARY HEALTH CARE THROUGH IMPROVED WATER SUPPLY,  
SANITATION AND COMMUNITY EDUCATION
- IV. SPRINGS AND SPRING PROTECTION
- V. SMALL SCALE DESALINATION
- VI. PUMPS AND PUMPING SYSTEMS

**WATER RESEARCH COMMISSION**

**A GUIDE TO:**

**GROUNDWATER EXPLORATION, USE  
AND CONSERVATION**

prepared by:

Division of Water, Environment and Forestry  
Technology, CSIR

## TABLE OF CONTENTS

1.	INTRODUCTION.....	1
2.	BASIC PRINCIPLES .....	1
2.1	THE ORIGIN OF GROUNDWATER .....	1
2.2	GROUNDWATER MOVEMENT AND WATER BALANCE.....	4
2.3	GEOLOGICAL CONTROL.....	4
2.4	GROUNDWATER QUALITY .....	5
3.	EXPLOITATION OF GROUNDWATER THROUGH WELLS AND BOREHOLES 7	
3.1	SITING OF BOREHOLES AND WELLS .....	7
3.2	DRILLING AND EXCAVATION METHODS.....	10
3.3	DRILLING CONTRACTS.....	12
3.4	BOREHOLE LOGGING.....	13
3.5	BOREHOLE/ WELL DEVELOPMENT.....	13
3.6	WELL TESTING (TEST PUMPING).....	14
3.7	PUMP SELECTION .....	14
4.	USE AND CONSERVATION OF GROUND WATER.....	15
4.1	BOREHOLE OR WELL MONITORING.....	15
4.2	BOREHOLE OF WELL MAINTENANCE.....	15
4.3	MANAGEMENT OF GROUNDWATER RESOURCES AND ASSETS .....	16
5.	REFERENCES.....	16



## 1. INTRODUCTION

Approximately 75% of the fresh water on earth is fixed as ice, mainly in the polar ice caps. Of the remaining 25%, 24% is groundwater, and the remaining 1% is surface and atmospheric water. Groundwater is the largest source of fresh water in storage on our planet. However, its distribution in many parts of the world varies greatly in concert with the distribution of suitable underground water-bearing rocks (aquifers). Although South Africa is not endowed with vast highly porous aquifers, these figures none-the-less point to the vital importance of groundwater as a resource for fresh water supplies.

Groundwater is particularly important in South Africa where most areas are either arid or semi-arid. Even in wet the wet areas of the country, groundwater is important during times of drought when many of the surface resources dry up. A lack of rain implies a critical lack of water for human and agricultural use.

Many misunderstandings, misconceptions and half-truths exist about the origin, occurrence, exploration and exploitation of groundwater. One example is the half-truth that groundwater moves in underground rivers similar to surface rivers - a condition which occurs only in some large dolomite caves and cavities. Another example is the misconception that there is enough useable groundwater everywhere below the surface of the earth, if one only drills deep enough;- many dry holes, many of them deeper than 100 metres exist. It is also not true that groundwater is always pure - many potentially harmful substances such as pesticides, sewage effluent, oil spills and so on can migrate into groundwater through seepage.

The following is an attempt to clarify where groundwater comes from, where and how it occurs and its proper usage.

## 2. BASIC PRINCIPLES

### 2.1 THE ORIGIN OF GROUNDWATER

Primarily, groundwater comes from **precipitation** such as rain, hail and snow. When precipitation falls to the ground, a portion of it is intercepted/trapped by plants, trees and buildings, another small portion remains in pools and puddles on impervious and/or impermeable surfaces, the largest portion **runs off** into streams and rivers whilst yet another fraction **infiltrates** into the soil.

The amount of each fraction depends on several factors including :

- ◆ The intensity and duration of precipitation
- ◆ The density and distribution of plant and tree cover
- ◆ The soil type and soil moisture content
- ◆ The slope of the land and thickness of pervious and permeable soils and rock
- ◆ The type and area of exposed rock or rock under a thin cover

The fraction that is trapped by plants and the fraction that runs off end up either **evaporating** or forming parts of rivers, lakes or seas. Of the fraction that infiltrates into the soil, some is absorbed by roots of plants and trees and released back through **transpiration** whilst some is

retained as **soil moisture**. If there was heavy infiltration or the soil moisture content was high, there becomes an excess of infiltrated water. This excess water then **percolates** further down into the underlying rock to occupy spaces between the rock particles (in the case of a porous rock) or occupies fractures, joints and other weak zones in the rock. In some areas, direct infiltration of water from rivers and streams into the underlying rock may occur downstream.

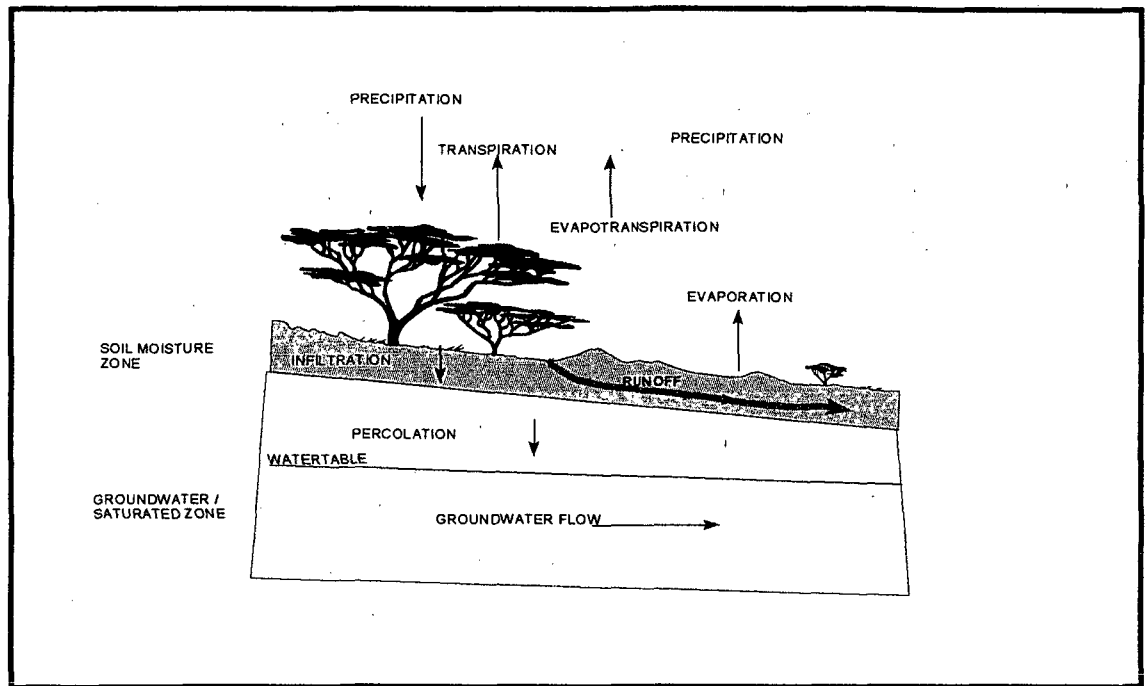

The underlying rock mass may contain large quantities of water but if the water is in unconnected pores or fractures, this water cannot be extracted. Thus, useful groundwater is that which occurs in large amounts in **connected pores or fractures**. When a rock mass has connected pores or fractures or cavities and is sufficiently saturated in extractable groundwater, it is called an **aquifer**. If it is saturated but the water cannot be extracted because the rock is porous but not permeable, the rock is called an **aquitard**. An aquitard may release some of its water through leakage into an aquifer. An **aquiclude** is a rock mass which may contain water but does not allow water to move through it. An **aquifuge** is a rock mass which does not contain water nor allow water to move through it.

Aquitards, aquicludes and aquifuges are very important because they determine where we are not likely to find water underground.

Basically there are two classes of aquifers:

- ◆ **primary aquifers** are aquifers in which water occurs and moves principally in the open spaces (pores/interstices) between the rock grains. Unconsolidated or consolidated porous sediments such as loose sand and sandstones

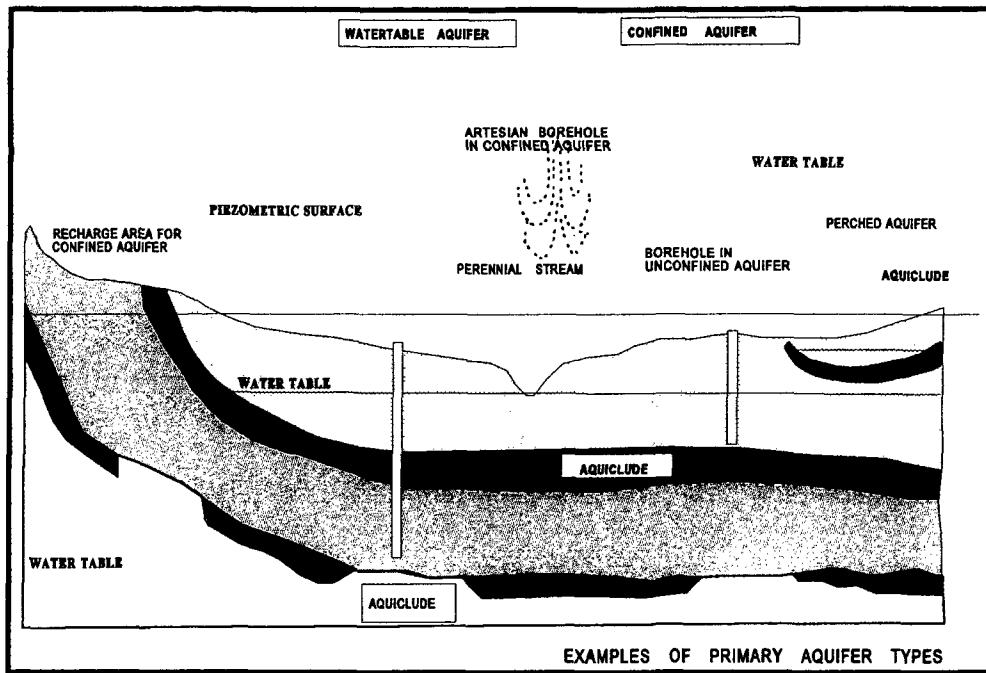

- ◆ **secondary aquifers** are aquifers in which water occurs and moves principally in the cracks between impermeable rock sides (fractures, joints), openings in fault zones (fissures), or cavities in soluble rocks such as dolomite.

South Africa has very few areas where uniform, porous or fractured aquifers occur and that is why groundwater is not found everywhere. That is also one of the reasons why borehole yields vary even in what appear to be similar environments. Other reasons include amount of precipitation, abstractions by other users, etc.

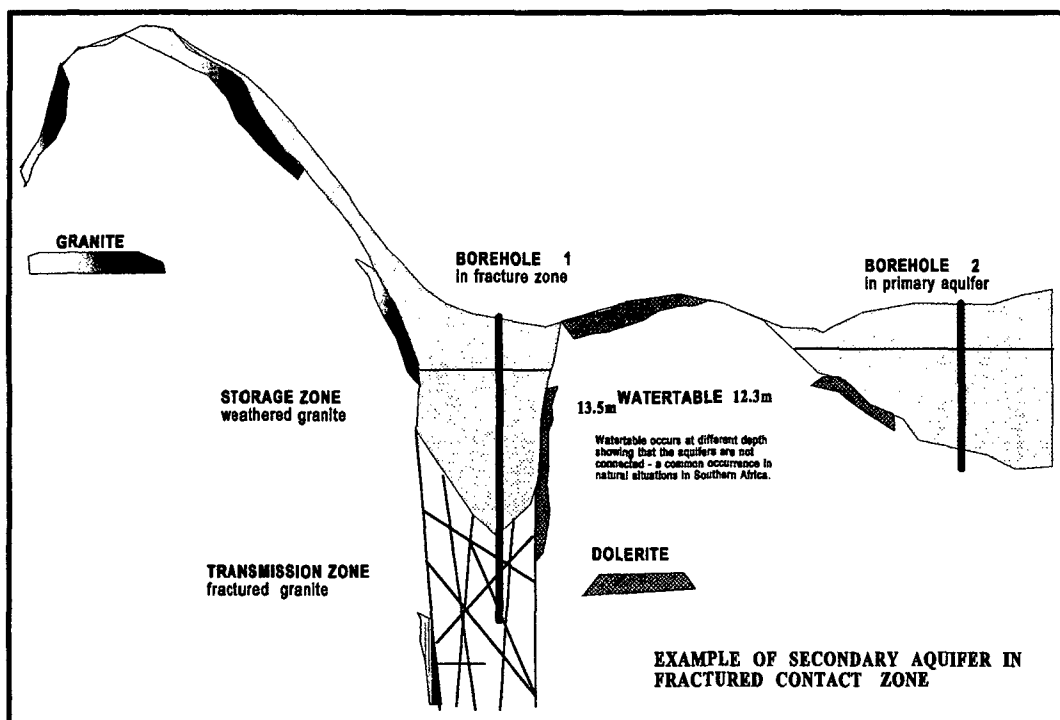

## 2.2 GROUNDWATER MOVEMENT AND WATER BALANCE

The upper surface that the water in a saturated aquifer rises to is called the **phreatic surface**. When the aquifer is not overlain by an aquiclude, the phreatic surface is known as the **water table**. In a uniform, porous aquifer, this level may form a continuous surface whereas in fractured rock, the water table may be irregular and discontinuous. The water table height is invariably not equal in all areas. In some places (usually high-lying), the water table is high and in lowlands, it is low. The groundwater table is simply the level in the ground where the rock formation is saturated, i.e. the point below which all the spaces between the rock particles are filled with water.

By physical laws, groundwater flows from areas of high water table (called high elevation head) to areas of low water table (low elevation head). In most instances, these areas correspond to high and low lying areas, respectively. *The movement is through the connected pores or fractures and not rivers or channels.* The rate at which groundwater flows is determined by the extent to which the pores or fractures are connected (permeability) and the difference in water table elevation (difference in head). The permeability together with the extent of saturation, determine the rate of flow to a borehole or well when it is pumped.

If the water table is lower than the base of a surface water body such as a stream, river or lake, leakage from the water body to the aquifer may occur. The reverse occurs when the water table is higher than the surface water body. This is the reason why some rivers continue to flow even when there is no precipitation.

The amount of water contained in an aquifer depends on the amount:

- ◆ Of infiltrated water (recharge) reaching the aquifer
- ◆ Lost from the aquifer through springs and seeps
- ◆ Extracted through boreholes and wells
- ◆ Gained or lost from or to surface bodies
- ◆ Lost through absorption by plants (evapotranspiration)

Where the water table is sufficiently close to the surface, direct evaporation into the atmosphere may occur.

The water balance, therefore is the difference between the amount lost and the amount gained by the above mentioned mechanisms. A positive water balance is when the amount gained exceeds the amount lost. If a negative balance occurs because of extraction through boreholes and wells, the process is called mining the aquifer.

## 2.3 GEOLOGICAL CONTROL

The major aquifer types can be summarised as follows:

- ◆ Unconsolidated or consolidated porous sediments such as loose sand and sandstones
- ◆ Fractured igneous and metamorphic rocks such as granites and quartzites
- ◆ Cavernous limestones and dolomites

The type of rock in which groundwater occurs is controlled by geological processes. On the

basis of these geological controls, the main types of aquifers can be re-classified in the specific context of South Africa as follows:

a) **Aquifers in rocks of the Karoo Sequence**

The Karoo sequence covers approximately 50% of the surface of South Africa. The sedimentary rocks in this sequence comprise sandstones, shale and siltstones, all of which have a low yield in general. These rocks have highly permeable fractures zones which can yield large amounts of groundwater. An irregular network of dolerite dykes also yield appreciable amounts of groundwater.

b) **Dolomitic aquifers**

Although only covering about 5% of South Africa, the groundwater potential of these formations is significant. Dolomite has a high storage capacity and permeability in the leached zones.

c) **Aquifers in igneous and other hard rock formations**

Aquifers in these formations only occur in weathered or fractured zones.

d) **Aquifers in unconsolidated formations**

There are some areas of South Africa where good water bearing unconsolidated aquifers occur. These may be found along the coastal areas, in the Kalahari, in alluvium filled river beds, and alluvial plains of rivers. The specific yield of these aquifers is generally very high.

## 2.4 GROUNDWATER QUALITY

Groundwater, although often free of pathogenic bacteria, may not always be suitable for general domestic and agricultural use. The water quality may change due to one or more of the following reasons:

- ◆ solution of salts from the source aquifer itself;
- ◆ man-made pollution from one of the following:
  - ◆ leaching or dumping of industrial wastes
  - ◆ leaching of agricultural products (fertilizers, insecticides, biocides, etc.)
  - ◆ seepage from **latrines**, sewage systems, and from waste dumps.

The desired quality of water is dependent on the use for which the water is required. Different levels of purity are required for human consumption, livestock watering, irrigation, industrial use, and recreational use.

In South Africa the following are the common quality problems encountered with respect to the use of groundwater for domestic purposes:

- i) **Salinity.** In many areas the available groundwater contains salt at levels which make the water less palatable. In some areas the water is so brackish that it cannot be used for human consumption. The source of the salinity may be from ancient marine sediments which now form the aquifer. An example of this is the Ecca Shale formation of the Karoo Supergroup, which gives rise to brackish underground water in the Eastern Cape.

- ii) **Iron.** Most groundwaters contain a certain amount of iron, usually as dissolved ferrous salts. On exposure to the atmosphere (oxygen), the iron in these salts is oxidised to ferric salts, which usually form precipitates in the holding tank. This same process may be responsible for the clogging of screens and gravel packs within a borehole. Increased levels of iron often occur in ground water due to corrosion of the borehole casings.
- iii) **Fluoride.** Fluoride levels which are excessive are found in certain groundwater sources in South Africa. While a certain amount of fluoride is usually beneficial for healthy teeth formation, an excess will lead to mottling of teeth and even damage to the bone structure of humans and animals.
- iv) **Nitrates.** High nitrate levels are found in certain groundwater. These arise from certain geological formations, but also from excessive use of fertilizers by farmers and seepage from sanitation systems. High nitrate levels may cause illness in babies, which could prove fatal in some circumstances.
- v) **Bacteria and other pathogens.** The occurrence of bacteria and other disease causing organisms (pathogens) in groundwater may be a problem in areas with a shallow water table. When wells or boreholes are located close to a latrine system, seepage of leachates and raw wastes may easily enter the well intake. For sands and finer materials, a water intake should be located at a distance not less than 30 metres from a latrine. For coarse materials, this distance should be further increased. In fractured rock aquifers, special construction of the latrines may be necessary. A groundwater specialist should be consulted for advice on appropriate distance.

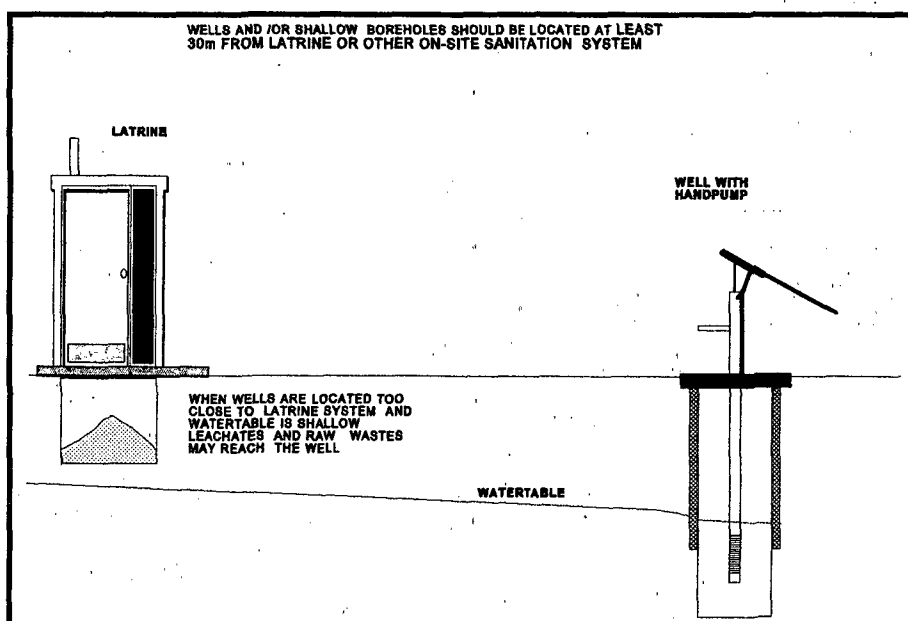

### 3. EXPLOITATION OF GROUNDWATER THROUGH WELLS AND BOREHOLES

Groundwater is a valuable source of water for use by communities. It is especially valuable in times of drought when other surface water sources may diminish and even dry up at a rate faster than will the underground sources. However, considerable care must be taken in the exploitation of groundwater resources, as over-hurried decisions may result in very costly mistakes. Important considerations in this section include the following:

- ◆ siting of boreholes and wells;
- ◆ drilling and excavation methods
- ◆ drilling contracts
- ◆ borehole logging
- ◆ well development
- ◆ well testing
- ◆ pump selection

#### 3.1 SITING OF BOREHOLES AND WELLS

It is very difficult to predict where to find the best sources of groundwater and to estimate the quantity of water which can be obtained at a particular site. However, by understanding a few of the basic principles of its occurrence in the ground, it is possible to obtain a reasonable measure of success.

Finding underground water has long been considered a subtle art. Forked sticks called divining rods have been used since ancient times to detect the presence of water. The subject of water divining is controversial. However, it is an often used method and there are reports that some diviners have had some impressive successes. One of the serious limitations of divining rods has been that what they indicate depends on who holds them. Although it can be shown that numerous successful boreholes and wells have been sited by divining, it can also be shown that this is mostly by chance. *Successful water-diviners even admit that they use some scientific or geological observations to "help" with their divining.* Most people who consult water diviners do so because diviner's fees are low. However, considering the cost of drilling and equipping a borehole, this may often prove to be false cost savings unless the water needs are small enough and the search area is part of a proven extensive aquifer.

In modern times man has gained a better understanding of the geological and geohydrological conditions which give rise to good water supplies, and has subsequently developed certain scientific techniques to improve the chances of striking a successful underground supply of water. Hence there are now a number of ways of siting a borehole or well which will greatly improve the chances of striking a good aquifer. These can be grouped into two main groups:

- ◆ estimation based on previous experience
- ◆ scientific methods

**a) Estimation based on previous experience**

In a number of instances no special techniques are required in order to site a borehole or well. These are generally where only small borehole/well yields (2000 per hour or less) are required in unconsolidated aquifers in high rainfall areas. A local driller who has many years of experience in a particular area may be able to achieve success without the need for further exploration methods.

**b) Scientific borehole siting**

Although not a sure, fail-safe method for determining the location, depth and quantity of underground water available, scientific methods can be used to greatly improve the chances for the siting of a successful borehole. These methods also provide especially useful information for siting and designing boreholes and wells and for drawing up appropriate drilling contracts in areas where there has been no drilling before. Scientific methods for borehole siting include:

**i) Obtaining relevant information**

The following geological, hydrological and other physical factors are usually taken into account in groundwater exploration:

**Geological**

- ◆ types of geological formations present and their potential as aquifers (e.g. unconsolidated sediments, dolomite compartments, sandstones)
- ◆ geological features such as faults, dykes, fractures, sills, etc.

**Hydrological**

- ◆ rainfall characteristics of the area
- ◆ groundwater recharge potential (e.g. from rainwater, streams and lakes)

Sources of relevant information which can be obtained before a field evaluation is undertaken are, inter alia, the following:

- ◆ aerial photographs
- ◆ geological and hydrogeological maps
- ◆ borehole information from other boreholes in the area (depth, yield, borehole log)
- ◆ satellite and infra-red aerial photographs

Note that some of this information can be obtained in South Africa by making use of the national Groundwater Database which is maintained by the Department of Water Affairs, Private Bag X313, Pretoria, 0001.

**ii) Field visit and assessment of site characteristics**

The information already obtained must then be compared with the actual features on the ground to select an optimum site. It is prudent to follow-up this geohydrological reconnaissance with geophysical exploration techniques even if there appear to be enough indications as to the possible presence of water underground. The information obtained will not only serve to confirm the observations, but will be especially useful in drawing up reasonable drilling specifications and for future reference. The geophysical exploration techniques include the following:



**Electrical Resistivity.** The resistance to the passing of an electrical current through the rock profile is measured. Because water is the primary cause of water conductivity in rock formations, this data can then be correlated to possible water bearing zones. The main value of this method when it is appropriate is that it provides a fairly good estimate of the maximum drilling depth. The cost of drilling increases with increasing depth.

**Electromagnetic Methods.** Different rock formations have different electromagnetic conducting abilities, which can be correlated with possible water bearing zones. Electromagnetic Methods make it possible to identify linear and areal features which may be clearly visible on areal photographs but not on the ground. In addition, linear aquifers such as dolomite cavities that are difficult to pick out from Resistivity methods can be identified more easily.

**Magnetic Method.** With this method, changes in the earth's magnetic field are measured. These can be related to subsurface geological contracts such as dolerite dykes. The magnetic method offers rapid assessment in places where dykes and/or other intrusions have a significant control on the occurrence of groundwater. Examples are karoo rocks with dolerite dykes, granite areas with quartzitic reefs and veins.

**Gravimetric Method.** Changes in the gravitational field of the earth as a result of differences in the densities and mass of the rock formations are measured relative to a reference point. In this way underground cavities (e.g. potential sink holes in dolomites), buried alluvial deposits such as ancient river valleys, etc. can be assessed.

When used by qualified and experienced scientists, these methods of borehole siting can lead to significant improvements in the success of borehole drilling programmes. The best value is obtained when the results of two or more methods are integrated.

The following table indicates the success rate of the various methods as used in an area of Zimbabwe<sup>1</sup> during the 1983-84 drought:

Technique	Percentage of successful boreholes
Integrated geophysical techniques	90
Hydrogeological reconnaissance	66
Aerial photograph interpretation	61
Logistical location	50

### **3.2 DRILLING AND EXCAVATION METHODS**

Having selected the optimum site for developing a ground water supply, a decision must be made on the method to be used - either to drill a borehole or to sink a well. This will depend on a number of factors, including the following:

- ◆ probable depth of hole
- ◆ nature of the overburden and subsurface formations
- ◆ availability of finances

For boreholes (generally used for depths of greater than 20 m) a reputable driller should be contracted. Boreholes are sometimes known as deep wells. If the community is not using a consultant to supervise the drilling works, some care should be taken when selecting a contractor to drill a hole. In particular the following should be checked:

- ◆ ensure that the contractor signs a contract that details all the costs that are likely to be incurred;
- ◆ the contractor's drill rods must be straight;
- ◆ check what casing the contractor is planning to use on the hole (steel or plastic - and what thickness?), and if he intends to install a screen, what type?;
- ◆ ensure that the driller will not stop drilling only because he hits "hard rock" or has reached a depth he arbitrarily likes;
- ◆ ask the contractor about borehole development, and how he will try to improve the yield of the borehole if necessary;
- ◆ ensure that the driller provides information on the material of each and every meter drilled, and at what depth the most promising water fissure is located;
- ◆ check what diameter the hole will be that the driller intends to drill - a good average diameter if a motorised pump is to be fitted is 150 mm (6 inches). Generally, the borehole must be at least 127 mm (5 inches) in diameter.

In order to achieve the best possible results, the community will find it prudent to employ a reputable consultant, who is not linked to the contractor, to design their borehole/s and supervise the drilling and construction.

For depths less than 20m, hand-dug wells, bored wells (also known as tube wells), jetted well-points, and driven well-points are the possible options. Some of the factors that influence choice of whether to dig, jet or drill are (there are many others):

- ◆ estimate of daily water needs to be met from the source
- ◆ number of households to be supplied

- ◆ type and size of pump to be fitted
- ◆ risk of contamination of the structure when finished
- ◆ estimated cost as compared to expected results
- ◆ whether or not water will be pumped to storage

Jetting and driving of well-points are best carried out by reputable contractors who have the appropriate equipment.

Jetting of well points is carried out by pumping water into the hole being sunk through a casing pipe string with an inside diameter large enough to carry the well-point screen assembly to be fitted. The sand and silt in the area surrounding the hole is removed by being forced to flow outside the pipe to the surface through being displaced by the incoming pumped water. After successfully reaching the desired depth, the pipe used is withdrawn, leaving the well-point screen in place for pumping water from the well. It is important to ensure that the water used in the jetting does not contaminate the aquifer and should ideally come from another well in the same aquifer. For practical reasons of pumping water under sufficient pressure during construction, jetted wells seldom exceed 10m in depth. The method is suitable in thick unconsolidated alluvial sands such as silted up dams or riverbeds, or coastal sands bearing fresh water. A lot of water is required during jetting and this may not be available in some areas.

Driven well-points are also constructed in similar environments. After driving a short length of casing into the sand formation, a well-point assembly is dropped into the casing. A driving bar or cylindrical hammerhead on a pulley is alternately raised and dropped to drive the well point into position out at the bottom of the casing. Care is needed in selecting the hammer and the stroke of the hammer action to avoid crushing the well-point screen into a mess of concertinaed wire. This method has an advantage over jetting in that water is not essential to the construction. However, problems may be encountered in aquifers which contain gravels.

Hand-dug wells are those excavated in unconsolidated sediments and weathered rock formations by use of picks and shovels or hand-held excavation machinery (e.g. jack-hammers). The well is lined with concrete, brick or masonry. Cement mortar is used from the top to the watertable to prevent contamination. When the watertable is reached during digging, the hole is kept partially dry by bailing with a bucket or pumping out the water. Digging stops when it is no longer possible to keep the hole dry long enough to dig for about half an hour without being flooded out. For this reason, it is best to dig a new well or deepen an existing one at the end of the dry season.

Bored shallow wells or tube wells are constructed in unconsolidated materials or heavily weathered/soft rock. The boring is carried out using either hand-operated tube well rigs or mechanically driven augers. The table below summarises possible methods for sinking wells.

<b>POSSIBLE METHODS FOR SINKING OF WELLS AND/OR BOREHOLES</b>		
<b>METHOD</b>	<b>HOLE DEPTH</b>	<b>PREFERRED SUBSURFACE FORMATIONS</b>
Jetting/driven wellpoints	1 to 10 m	Unconsolidated sediments
Hand dug wells	1 to 20 m	Unconsolidated sediments or weathered rock formations
Tube wells	10 to 20 m	Unconsolidated sediments
Borehole sinking	15 to 500 m	Hard rock formations

### **3.3 DRILLING CONTRACTS**

Drilling a borehole is expensive. It is therefore important to ensure that there is a proper and fair contract between the driller and the community representatives. There should be a clear, unambiguous common understanding of what the community or their representative/consultant is asking the drilling contractor to do and what the drilling contractor is undertaking to do. Some of the important points to look out for in the contract are:

- ◆ minimum damage to the site and its surroundings during the drilling; and the site should be left in a safe and sanitary condition on completion of the work
- ◆ drilling should be carried out with due professional care according to the latest standards or best-practices. One way of minimising the risk of selecting an inappropriate contractor is to seek the opinion of the Borehole Water Association of South Africa, P.O. Box 2178, Southdale 2135 before signing any contracts.
- ◆ the equipment to be used (especially the drilling rods) is sufficient and in good enough condition to produce a straight and plumb borehole of agreed depth
- ◆ any casing and screens that are to be installed in the completed borehole should be of appropriate standard and free of any damage (e.g. rusted metal casing, bent or dented screens, damaged threads if casing is threaded, etc.).
- ◆ there should be no contamination of the aquifer of any kind during and after the drilling
- ◆ the completed borehole should be developed skilfully and professionally to improve yield by removing fines particles from the immediate area around the borehole. This will also reduce the risk of potential damage to the permanent pumping plant. Development also reduces friction near the screens or slots.

- ◆ the driller should keep records of all the work, materials used, water and aquifer conditions encountered, etc. and supply copies to the client or the client's representative upon completion of the work
- ◆ the driller must meet all statutory obligations as well as indemnify the client from any potential litigation whatsoever that could arise as a result of the drilling and any ancillary work being or having been performed.

### 3.4 BOREHOLE LOGGING

There are a number of records which must be kept during the drilling and completion of a borehole. The **geological log** is the record of the rock through which drilling is progressing. Unless the contract specifies differently, samples of the drill cuttings from the borehole are taken at one metre intervals. Additional samples are collected where the rock type changes. The geological log is written by a geologist or a hydrogeologist who is normally on the staff of the consultant employed to supervise the driller by the client. Some drillers may have a geologist on their staff who could write the geological log. An experienced driller who has no formal geological training can also make his own record, which is called a driller's log.

The **penetration log** is a record of the number of metres drilled every minute. The main value of this log is that it gives information on hardness of the rock and/or position of water bearing fractures among other things. Such information is useful in designing the borehole.

Other records which the driller or consultant should keep include a record of:

- ◆ depths at which water is struck and how much water is struck at that depth
- ◆ any changes in the drilling method, including use of drilling additives
- ◆ the casing and screens used

**Geophysical logs** are sometimes run in new boreholes especially when drilling in areas where no boreholes have been drilled before. This information is highly useful in sandy formations where it may be necessary to install expensive borehole screens. These logs are normally run by specialist consultants.

### 3.5 BOREHOLE/ WELL DEVELOPMENT

The process of drilling a borehole causes undesirable changes in the formations in the immediate area near the hole. Some of these changes are undesirable. For example, fine particles may be pushed into fractures and pores, closing off the movement of some water. It is therefore important to repair this damage and restore the natural water transmitting properties of aquifer formations. This corrective action is known as borehole or well development.

There are several methods of developing wells to remove fine particles. The important thing is to select a method which allows alternating forward and backward movement of water out

of and back into the aquifer in a surging action. This movement ensures that the development does not leave "bridges" of granular particles that could prevent water from moving freely into the borehole through the screens and/or slotted casing.

Borehole development can also be carried out to change the character of the natural rock formation immediately around the borehole/well in order to improve the flow of water from the aquifer into the borehole. In unconsolidated formations clay and silt size particles are removed using the methods mentioned above for repairing damage. An example of the methods in hard rock formations is hydrofracturing. The aim of hydrofracturing is to increase the openness or size of the fractures through which groundwater moves.

### **3.6 WELL TESTING (TEST PUMPING)**

The primary objective of test pumping (or pumping tests) is to determine the rate at which the borehole can be pumped in order to provide a constant supply of acceptable quality water over a long period. The test pumping provides an understanding of the long term effects of pumping on an aquifer, changes in water quality with time, the geohydrological characteristics of the aquifer, and the radius of influence around the borehole.

Tests carried out for these purposes can involve continuous pumping for 24 hours or longer (e.g. 90 days), depending on geological conditions and the purpose for which the borehole has been drilled. As an example, a borehole required for reticulated municipal water supply or irrigation may require a 30-day or more test, while a borehole to be fitted with a handpump for local domestic water supply or livestock watering may need only a 24-hour continuous pumping test.

In addition, pumping tests are a means of working out the efficiency or performance of a borehole as a hydraulic structure and to select the optimum pump for the borehole. These tests can last from one hour to eight hours and may involve incrementally changing the rate in stepwise manner.

Test pumping should be conducted by a suitably equipped and qualified test pumping contractor under the supervision of a geohydrologist. The analysis of the data collected during a test must also be done by a geohydrologist. Pumping tests should only start once the water level has returned to its static level.

### **3.7 PUMP SELECTION**

The choice of a pump to install in a well or borehole depends on a number of factors which include:

- ◆ the amount of water needed from the well
- ◆ the capability of the borehole/well to supply that amount of water as determined from the pumping tests
- ◆ the distance of the well/borehole from the community to be supplied
- ◆ the ability of the community to run and maintain the pumping plant or the security of funding for operation and maintenance
- ◆ the capital cost and available power sources.

Handpumps constitute a practical choice for low water demands in small communities (e.g less than 16 households). Practical experience shows that for higher populations extra boreholes and handpumps will be necessary to avoid excessive queuing and/or excessive wear of the pump. In that case, it may be more economical to choose motorised pumps. Other situations where motorised pumps are necessary include lifts greater than 60m, steep gradients to/from borehole to homestead, long distances, etc.

The selection of pumps should be done in consultation with a pump manufacturer. For the selection and installation of borehole pumps, it is advisable to obtain the services of a professional pump installer. The electrical installations have to be carried out by a qualified electrician. Consulting engineering companies specialising in water distribution systems should do the design of a reticulation system.

## **4. USE AND CONSERVATION OF GROUND WATER**

A water supply system should be considered by every community as one of its most valued resources, and should therefore be carefully monitored and looked after. Besides just keeping the area clean and protected, the following additional steps should be taken to protect and conserve this valuable asset.

### **4.1 BOREHOLE OR WELL MONITORING**

A well-looked after borehole is likely to last longer. The water committee should appoint a person who can be trained to monitor all the boreholes and wells on a full time basis. Borehole or well monitoring involves the following:

- ◆ Taking water levels on a regular (usually monthly) basis and recording it. This helps to determine whether the aquifer is drying up and therefore regulating pumping rates and times. These records also give valuable information which helps to anticipate and plan for water shortage problems such as drought, overpumping, and others.
- ◆ Taking water samples for quality analysis at intervals that may range from a few months to several years. Quality analysis helps to detect contamination of groundwater early and therefore take preventative or corrective action early enough before people start getting sick from contaminated water.

### **4.2 BOREHOLE OR WELL MAINTENANCE**

One of the most frequent problems with boreholes is the breakdown of pumps that render an otherwise productive borehole useless. Like a well-maintained vehicle, a pump which is well looked after lasts a long time and is reliable. On the other hand, a neglected pump breaks down frequently, leaving people without drinking water and ultimately wears out in much less than the design life.

Borehole or well maintenance can be carried out at two levels. Firstly, a water committee appointed local resident can perform the following maintenance duties:

- ◆ Ensure that children, vandals and livestock do not damage the borehole and pump.
- ◆ Keep the pump clean and oiled at all times.
- ◆ In certain instances, he/she can effect minor servicing of the pump.

Secondly, borehole rehabilitation and major pump servicing and even reinstallation should be carried out by a suitably qualified and experienced practitioner. This usually is done at intervals of several years as it is rather costly.

### **4.3 MANAGEMENT OF GROUNDWATER RESOURCES AND ASSETS**

The process of exploration, siting, drilling and fitting of a borehole or well is expensive. Proper management of the aquifer, borehole(s) and well(s) is therefore of utmost importance. Moreover, many communities in villages and towns depend entirely on groundwater for survival. In addition to the monitoring and maintenance mentioned above, a detailed management plan should be drawn up. This plan should ideally cover the whole aquifer and not just the borehole(s). Again, a groundwater practitioner, in co-operation with the local community, will help to draw up such a plan.

## **5. REFERENCES**

Sami K and Murray EC (1998) Guidelines for the evaluation of water resources for rural development with an emphasis on groundwater. WRC Report 677/1/98.

Conference papers (1995). Ground water recharge and rural water supply. Volkswagen Conference Centre, Midrand, South Africa. 26-28 September 1995.

Hofkes, E.H. (editor) (1983) Small Community Water Supplies. John Wiley & Sons. Chichester.

Arlosoroff, S. et al. 1987. Community water supply. The handpump option. Washington, DC: World Bank.

Fraenkel, P. 1986. Water—pumping devices. Intermediate Technology Publications, London, 171p.

Borehole Water Association of Southern Africa. Groundwater: Guidelines for boreholes

CSIR (1991) Guidelines on the cost effectiveness of rural water supply and sanitation projects. Water Research Commission Report 231/1/93.

Todd DK (1980) Ground Water Hydrology. John Wiley & Sons



Xu Y and Braune E (1995). A guideline for groundwater protection for the community water supply and sanitation programme. Department of Water Affairs and Forestry, Pretoria.

Intermediate Technology Publications (1990). A ground Water Primer.

White,C. 1987. Borehole siting using Geophysical methods. Developing World Water. Grosvenor Press International, Hong Kong. pp 106 - 113.

**PRIMARY HEALTH CARE THROUGH IMPROVED  
WATER SUPPLY, SANITATION AND  
COMMUNITY EDUCATION**

prepared by:

Division of Water, Environment and Forestry  
Technology, CSIR

## TABLE OF CONTENTS

INTRODUCTION .....	3
THE AIM OF THIS MANUAL.....	4
WHAT THIS MANUAL IS ABOUT .....	4
1.HEALTH IMPACTS OF WATER SUPPLY AND SANITATION.....	5
1.1 Incidence of water and sanitation related diseases in South Africa.....	5
1.2 Spread of water and sanitation related diseases.....	6
2.WHAT IS HEALTH AND HYGIENE EDUCATION?.....	9
2.1 Learning principles .....	10
2.2 Teaching methods .....	11
2.3 Phases of a hygiene education programme.....	12
2.4 Specific matters which should receive attention.....	13
2.5 Primary Health Care Programmes.....	14
3.HEALTH EDUCATION PLANNING.....	15
3.1 Phase 1: Outcome.....	16
3.2 Phase 2: Behaviours .....	17
3.3 Phase 3: Identification of factors .....	17
3.4 Phase 4: Health education plan.....	18
4.STAGES OF THE HEALTH EDUCATION PROGRAMME.....	19
STEP 1: Formulation of aims and objectives .....	19
STEP 2: Planning.....	20
STEP 3: Assessment of existing situation .....	20
STEP 4: Analysis of information .....	21
STEP 5 Implementation Plan.....	22
STEP 6 Implementation.....	22
STEP 7 Monitoring and Evaluation.....	23
5. CONCLUSION AND GENERAL .....	24
APPENDIX 1: USEFUL REFERENCES FOR FURTHER READING .....	26
APPENDIX 2: RANGE OF POSSIBLE USEFUL SOCIAL AND HEALTH INFORMATION .....	29

## INTRODUCTION

Water and sanitation related diseases such as various types of diarrhoea, worm infestations, skin and eye infections and vector-borne diseases account for a significant proportion of morbidity and mortality, particularly among infants and the elderly, in developing countries. Water supply and sanitation programmes aim to reduce the incidence of these diseases and thereby to contribute to improving public health, to reducing curative health costs, to improving attendance at schools and to decreasing production losses resulting from poor health and illness of students and workers. However, it has been increasingly recognised that the provision of these services is insufficient to reduce the incidence of water and sanitation related diseases. In addition to the provision of these services, changes in personal and community behaviour in terms of hygiene and environmental cleanliness are required. Health and hygiene education in the context of the socio-cultural environment is a means to address these behavioural changes and thus to provide the essential link between improved water and sanitation facilities and improved health.

It is vital that the health and hygiene programme be addressed to the community as a whole and not just the community leaders or a specific group within the community. Health and hygiene educational programmes, preferably using members of the community as participants and facilitators, should be incorporated into all water supply and sanitation projects with an appropriate budget, or alternatively be launched on a regional basis in a number of neighbouring communities where water supply and sanitation projects are planned or are in the process of being implemented. In the latter case, the health education programme becomes an important motivation for communities to embark on water and sanitation projects.

The context of "primary health care" would be the most appropriate vehicle for such a health education programme. It is therefore important that links with local and regional health programmes including the Department of Health be established at the initial stage of a project to coordinate the programme.

Principles of adult education should be consciously utilized in programmes of this nature for maximum efficacy. Special attention must be given to ensuring that women are included at all stages, and in all aspects, of the implementation of these programmes.

This guide does not include technological details of health education programmes; but does recommend approaches that should be adopted by development agencies considering community upliftment and health education programmes related to water supplies and sanitation facilities.

## **THE AIM OF THIS MANUAL**

This guideline manual is written for development agencies involved in water supply, sanitation and primary health in urban and rural communities. One of its main purposes is to indicate how the improvements in water supply and sanitation can be linked to primary health education programmes to ensure that these investments can make a significant impact on the health of communities. Guidelines are given on how to formulate health education interventions linked to water supply and sanitation programmes such that these programmes address the communities at a level where the highest impact on personal hygiene behaviour can be assured.

This guide may also be used to design a health education programme prior to a latrine provision project being implemented. This is an important component of creating an awareness and demand for improved sanitation in an environment where individual families and institutions are called to make personal financial contributions to these programmes.

It is also very important for development agencies to coordinate water supply, sanitation and health education activities with the local Department of Health and Department of Water Affairs offices, and with other organisations in the region who can make a contribution to the projects. An effective hygiene education programme may contribute significantly to ensuring the longer term sustainability of water supply and sanitation projects.

## **WHAT THIS MANUAL IS ABOUT**

This manual provides information on health aspects of water supply and sanitation, and the important components of and approach to a health education and awareness programme for projects in developing communities. It also describes how to plan and implement a health and hygiene education programme for water supply and sanitation projects.

It is important to remember that although this book gives guidance on how to develop and run a health education and awareness programme in a community, all communities are different and education programmes must preferably be customised to the needs of each community to have the most impact in the longer term. Hence it is considered of utmost importance that health education programmes remain flexible enough to be changed to meet the particular circumstance of each project, and that people with a high level of knowledge and understanding of the situation in each community be part of the planning team.

## **1. HEALTH IMPACTS OF WATER SUPPLY AND SANITATION**

### **1.1 Incidence of water and sanitation related diseases in South Africa**

Projects for the improvements of water supplies and/or sanitation facilities could have a significant impact on the incidence of illness and diseases within a community. In particular improved domestic water supplies and sanitation will generally reduce the opportunity for the spread of diarrhoea illnesses by contaminated water or food, and by the lack of ability to maintain domestic cleanliness. But how important are these measures for reducing the incidence of diseases? The following figures derived from various surveys in South Africa and internationally give some indication of how prevalent water and sanitation related diseases are, particularly amongst children under 5 years of age.

In South Africa it is estimated that annually there are in excess of 1,5 million cases of diarrhoea in children under the age of 5 years. Mortality rates are estimated to be greater than 20 per thousand population in the 0 to 1 year age group, of which at least 25% are due directly to water and sanitation related diseases. There are together over 10 000 deaths annually from water and sanitation related diseases in South Africa. These figures could be significantly higher since many cases are never reported.

The other side of this picture is the high cost of medical attention, adult labour and child learning time, unproductive activities, and personal sorrow and grief. While not wishing to over-emphasize the cost of labour and lost production, these factors should be considered when costing different intervention options. Furthermore although the state will supply medical support at minimal cost to poor communities, many of the other costs are borne by those who can least afford to incur such costs.

### **1.2 Spread of water and sanitation related diseases**

Since most water and sanitation related diseases are spread from an infected or sick person through a particular transmission route to a healthy person, it is important to understand these disease transmission routes in order to prevent or minimise the spread of diseases.

Excreta from a sick person usually carries millions of micro-organisms which can cause the disease in other people if they come into contact directly or indirectly with the organisms in the infected excreta. There are a number of types of organisms and possible transmission routes for the spread of these diseases. These include those listed in the following table:

TABLE 1.1: Transmission routes for water and sanitation related diseases.

Transmission route	Description	Disease group	Examples
1. Water-borne through microbiologically contaminated water	transmission through consumption of contaminated water	faecal-oral (non-bacterial)	Poliomyelitis Hepatitis A Rotavirus diarrhoea Amoebic dysentery Giardiasis
		faecal-oral (bacterial)	Bloody dysentery (shigellosis) Cholera E.coli Campylobacter Typhoid Paratyphoid
2. Water-washed sanitation related	transmission through inadequate use of water for domestic and personal hygiene	faecal-oral and skin and eye infections	as for 1 + trachoma scabies
3. Soil- and animal-transmitted	transmission through contact with faeces disposed in shallow soil, or consumption of meat of infected animals	helminths (worms)	ascariasis hook worms tape worms ring worms trichuriasis
4. Water-based through contact	transmission via an intermediate host that lives in the water	Helminths	schistosomiasis (billharzia)
5. Water-site related insect vector	transmission by insects which breed in or near water	insect-vectors	malaria filariasis onchocerciasis

A number of measures can be taken to minimise the transmission through each route. These measures are key components of water supply and sanitation improvement projects and health education and awareness programmes. However, to be effective in creating barriers to the transmission route, these intervention programmes must focus on the physical and the socio-cultural environments of the communities.

The aim of improving primary health through water supply, sanitation and health education interventions must focus on the development of "sanitation barriers" which place a barrier in the transmission routes of each of the disease transmission systems.

The following table indicates the relative importance of improved water supplies, accessible sanitation and hygiene practices as sanitation barriers to reduce infections through the prevention of the transmission of water and sanitation related diseases.

TABLE 1.2: Prevention of transmission of sanitation related diseases

Disease group	safe drinking water	safe excreta disposal	personal and domestic hygiene	food hygiene	wastewater disposal - drainage
diarrheas (bacterial and non-bacterial)	••	•••	•••	•••	
Poliomyelitis, Hepatitis A	•	••	•••	••	
worm infections: ascariasis, trichuris hookworm pinworm, dwarf tapeworm other tapeworms guinea worm	•    •••	••• ••• •• •••	••• • ••• •	••  • •••	•
skin infections eye infections			••• •••		•
schistosomiasis (bilharzia)		•••	•••		•
insect vector: malaria yellow fever filariasis					• •• •••

Importance of preventing disease transmission: ••• high •• medium • low

This table indicates the high importance of accessible sanitation and household hygiene practices in creating sanitation barriers to the transmission of these disease types. Since a good water supply is a necessary requirement for personal and household hygiene, and to a certain extent food hygiene, wastewater disposal and excreta disposal, it is highly relevant in the prevention of disease transmission since it is actually a component of all the columns.

The specific diseases of malaria and schistosomiasis (bilharzia), which have a high prevalence in certain areas of South Africa, require not only improved water supplies, sanitation and domestic hygiene to control, but also the application of additional precautions such as:

- reduced contact with open infected water bodies;
- sufficient improved water supplies for bathing and washing;
- precautions to avoid mosquito bites;
- control of all mosquito breeding sites.

In some areas the Department of Health have field staff dedicated to malaria control programmes.



## 2. WHAT IS HEALTH AND HYGIENE EDUCATION?

In the context of water supply and sanitation, health and hygiene education is defined as *all activities aimed at encouraging behaviour and conditions which help to prevent water and sanitation related diseases*. An important aspect of this is the imparting of information and knowledge on the different disease types and their transmission routes, and the methods for preventing spread of the disease in the specific communities.

From this definition it is clear that health and hygiene education relates to different activities for different groups of people and for different communities. Most hygiene education will take place at the community level, encouraging men, women and children to look after their facilities and to increase hygienic practices such as using latrines, washing hands, and the safe storage of food and drinking water.

Because of the different nature and geographical location of communities from one another, each health and hygiene education programme will need to be specifically customized for each community. For this reason there should be collaboration with representatives of communities in the preparation of the health messages and materials to be used in the health and hygiene education programme. The materials used in the programme should reflect village life and recommended behaviours. There will usually be a number of common factors which relate to all communities within a region and a few factors specific to individual communities. By ensuring that the community specific factors are addressed in the programme, the impact of education on the factors common to the region is further enhanced.

In this technical guide the focus is on health and hygiene education as an integrated component of a water supply and sanitation project. However this must be seen in the context of other health promotion activities of the Department of Health and other agencies when planning a programme for a particular region or community. It is therefore necessary to coordinate and cooperate with district environmental health officers (EHOs), Care Groups, and other primary health care campaigns.

### 2.1 Learning principles

Since health and hygiene education is aimed to a large extent at adults in the community, principles of adult basic education and training (ABET) should be adhered to. The following points should be taken into account when planning a health and hygiene education programme for adults:

- i) People remember    20% of what they hear  
                               40% of what they hear and see  
                               80% of what they discover for themselves

Hence education should stress learning more than teaching.

- ii) Adults have a wide experience and have learnt much from life. They learn most from their peers. So teachers/trainers should encourage and help participants share their own experiences and create situations where they are encouraged to have a dialogue with one another.
- iii) Adults are interested in and learn quickly about those things that are relevant to their lives. Hence representative members of the community should share in the planning and choice of topics of the programme, and participate in regular evaluation of what they are doing.
- iv) Adults have a sense of personal dignity, and should be treated with respect at all times.

To be most effective, trainers and educators must then get to know each community before planning the health and hygiene education programme. This includes learning some of the socio-cultural activities and practices within the community, and studying the possible disease transmission risks prevalent within that community.

## 2.2 Teaching methods

Three broad approaches to health and hygiene education have been used. These are as follows:

### *Didactic Approach*

This is the most frequently used, but probably least effective, approach. Target groups are instructed to adopt certain practices in order to overcome hygiene related problems as identified by the project agency.

### *Promotional Approach*

This approach which commonly uses social marketing is characterized by the careful consideration of the target group's needs and preferences. The objectives and content of the programme are still largely determined by the project agency, but specifically addressed at the needs and preferences of the target groups. The health and hygiene messages are introduced through promoting the inherent benefits of

each behaviour, including non-health benefits like improved status, better looking homes, and building community spirit. This is a realistic approach when addressing single, widespread and urgent health risks. Large numbers of people can be reached in a short period and at relatively low cost. For a sustained impact and more complex behavioural changes, this approach is less effective.

### *Participatory Approach*

The participatory approach aims to create conditions to help people to solve their own problems. The objectives, contents and methods are determined as far as possible interactively by the target groups and the educator. Problem-based learning is an important aid which is used in this approach, with problems being drawn from the real experiences of the people.

To the extent possible, the participatory approach should be adopted to ensure the maximum acceptance and impact of these programmes.

### **Participatory Teaching Strategy**

The basic strategy in the participatory teaching approach should include the following the following methods:

- i) creating opportunities for active involvement through connecting ideas with people's real life experiences, questions, meanings and motives;
- ii) stimulating the imagination by encouraging people to view a situation from a variety of opinions and perspectives, thereby "seeing" reality not yet created (role plays are an important aspect of this);
- iii) encouraging critical thinking by guiding the people to relate information to inner resolve, will and values;
- iv) ensuring that training is aligned with reality in terms of what is possible, appropriate and will actually work (or alternatively to work on real rather than simulated situations, issues and concerns);
- v) teaching participants how to trust, value and use their own experience, and hence instill self-confidence, self-reliance and self-sufficiency;
- vi) using individual and group methods of reflection; and
- vii) using team work in exercises.

Participative training requires an open-ended and unconditional commitment by the trainers, but holds the potential for creatively enhancing organisational and community effectiveness to a substantial degree.

### 2.3 Phases of a hygiene education programme (based on a participatory approach)

As with the water supply or/and sanitation project itself, community participation must be an integrated part of the health and hygiene education process at all stages of the programme. This implies that as a first step key community representatives must be approached to participate in the process. The selection of a proportion of women representatives is vital since women tend to be more aware of health and hygiene practices within the home and community. Within this context, the following phases of a hygiene education programme should be considered:

Phase	Purpose	Target group	Intended outcome
Identification	Identification of health problems and of health related behaviour	Development agency Community representatives Health officials	A key list of health problems and the rationale for certain behaviours
Planning	Development of a plan of action for the implementation of the programme	Development agency Community representatives Health officials	A consensus detailed plan of action with agreed responsibilities and programme schedule
Selection of health promoters	Selection and training of village health promoters	Responsible village volunteers	A few trained village health workers to participate in the programme
Design	Design and pre-testing of messages and methods of communication	Community health promoters nurses, health officials	A selection of most effective hygiene messages and communication methods
Education programme	Encourage healthy behaviour and care of facilities	community members	Positive attitude to water and sanitation facilities, improved hygiene practices
Evaluation	Assess relevance of programme and/or modify where necessary	Development agency Community representatives Health officials Community health promoters	On-going sustainable health improvement programme

These phases are dealt with in more detail below. However the importance of the pre-programme work to ensure that the methods and messages are relevant and topical cannot be over-emphasized.

## 2.4 Specific matters which should receive attention

In defining priorities for health and hygiene education programmes, distinction needs to be made between those practices which are positive or neutral and those which are genuinely harmful. Only the latter should be targeted for change in the programme. Positive practices should be recognized and encouraged.

The following specific matters should be considered when assessing the priorities of the educational programme:

- links between behaviour, disease transmission, and environmental sanitation;
- protection of the water source;
- water collection methods;
- water and food storage;
- water use (including for personal and domestic hygiene);
- hand washing;
- food preparation and handling (including infant feeding);
- excreta disposal and use of latrines;
- latrine cleanliness;
- kitchen hygiene;
- waste water disposal;
- separation of living areas from livestock;
- insect breeding areas.

A careful analysis of the present practices and situation regarding each of these will help to pin-point the main requirements of the health education programme.

While behaviours from a survey should be specifically targeted, the programme should also be used as a vehicle for imparting knowledge to residents. The education programme should not only address behaviour change needs, but put health problems into the context of disease transmission routes and preventative mechanisms. To this end the following main topics should be dealt with:

- description of water and sanitation related diseases prevalent in the areas where the community members mostly reside;
- transmission routes of these diseases;
- typical conditions which promote these transmission routes;
- methods for the prevention of transmission; and
- other disease control methods.

## 2.5 Primary Health Care Programmes

Health and hygiene education programmes for water supply and sanitation projects should be seen in the context of a basic primary health care programme. Basic primary health care education generally includes a number of additional matters of household health care. A widely adopted primary health care focus is the so-called GOBIFFFF system where emphasis is placed on a number of different primary health care aspects. These are:

- G - growth monitoring of infants
- O - oral rehydration therapy for recovery from diarrhoea
- B - breast feeding
- I - immunization
- F - fertility control (family planning)
- F - food supplements (nutrition)
- F - female education (and female hygiene)
- F - first aid

These other aspects are not a necessary part of a water and sanitation programme, but may be incorporated should participating health officials wish to adopt an integrated health education programme. Water supply and sanitation issues would normally be addressed as part of female education in a primary health care programme, but when part of a water supply and/or sanitation project, these aspects should receive prominence and be addressed at all community members. The primary health care programmes do emphasize the importance of targeting women as primarily responsible for household health and hygiene, and the prevalence of infant diarrhoea as a basic health problem in rural and urban developing communities. The records of hospitals and clinics in rural areas confirm that diarrhoea in children is one of the most frequently reported cases dealt with.

## 3. HEALTH EDUCATION PLANNING

Health and hygiene education is a planned activity and must be properly designed and conducted if it is to be effective. In planning it must be noted that behavioural change is based on voluntary participation, and hence health education without participation runs the risk of being rejected or ignored.

Planning then should be carried out with the participation of representatives of the men, women and youth in the target populations.

Health education can be divided in four phases as summarised in figure 2.

### 3.1 Phase 1: Outcome

Planning starts in phase 1 with the outcome end. Here the general problems of concern to the people in the target communities are identified, and the health specific problems are prioritised. It is necessary to ensure that the target communities are interested in tackling these problems, even if it be for reasons other than health.

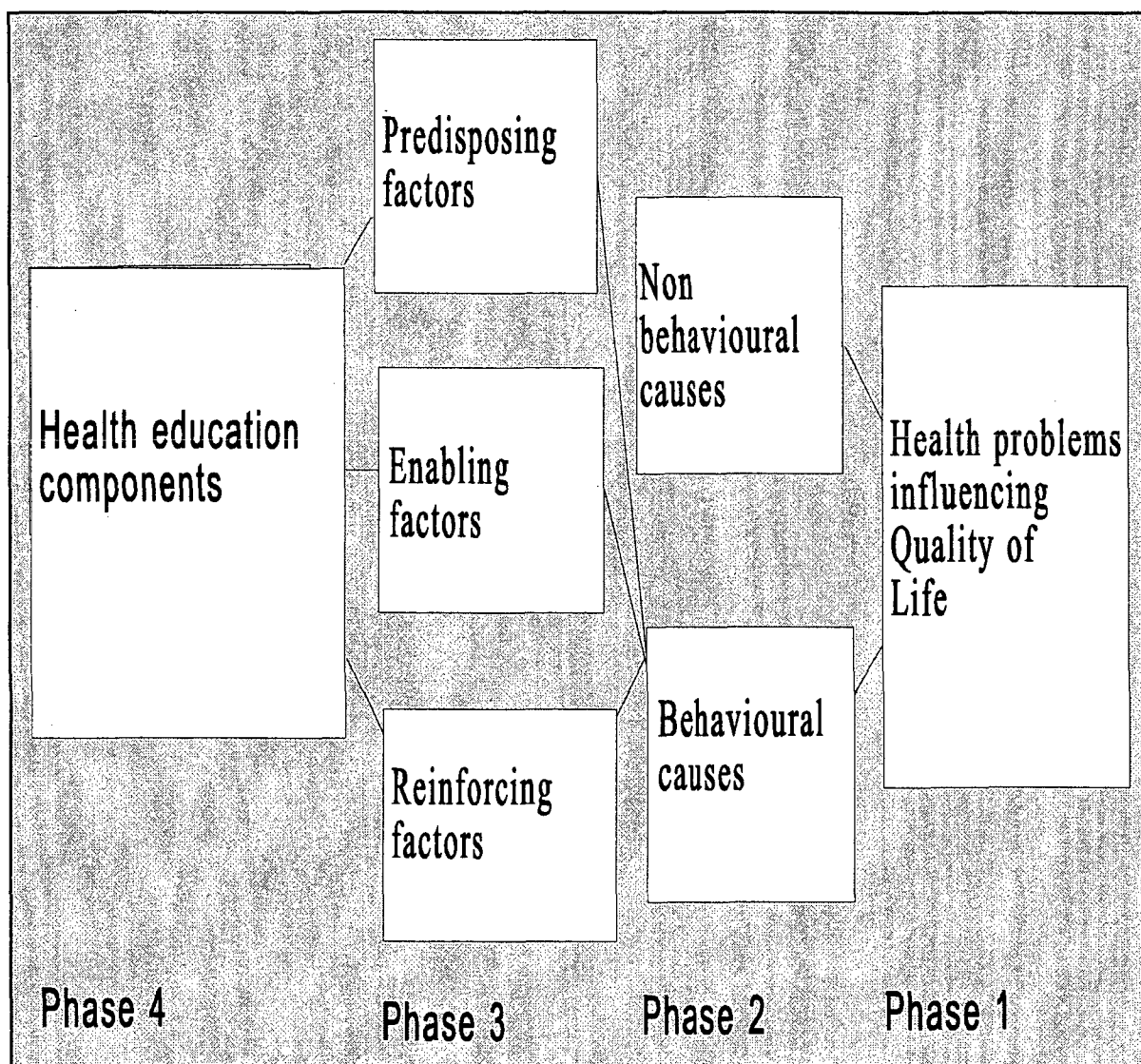

Figure 2: Phases of health education

### 3.2 Phase 2: Behaviours

In this phase the causes and specific behaviours linked to the priority health problems are identified. It will be necessary to isolate those behaviours which are water and sanitation related to take further as part of the health education programme, but to bring the attention of local health officials those behaviours identified as important factors with respect to other health related problems not related to water supplies and sanitation.

The water and sanitation related behaviours must form the focus of the educational intervention. It is therefore important that these behaviours are identified very specifically, and then ranked according to importance and changeability. The priority target for the health education programme will be those behaviours which are both important and easily changeable. However, expectations must be realistic with those behaviours which are considered important but less easy to influence.

Ultimately it will be necessary to make a balanced choice of the behaviours to be addressed by the programme. The health education programme should not try to achieve too much and must therefore be focused and have specific objectives.

For each target health behaviour immediate and medium term objectives should be formulated. These objectives should be defined as precisely as possible to further focus the education programme. Appendix 1 is an example of objectives and target groups of a health education project linked to a water supply and sanitation programme in Thailand.

### 3.3 Phase 3: Identification of factors

In phase 3 the factors which contribute to the target behaviours are identified. Usually many factors contribute to an actual behaviour and it may require further surveys in the communities to ascertain the nature of these factors. These factors can often be grouped into the following three categories:

- predisposing factors,
- enabling factors, and
- reinforcing factors.

Predisposing factors are these related to a person's knowledge, attitudes, beliefs, values and perceptions. These factors, as well as factors of socio-economic status, age, gender and family size, provide the motivation for an individual or group to act in a certain way.



Enabling factors are the resources available to perform a particular health behaviour. Resources include:

- |                    |   |  |
|--------------------|---|--|
| people resources   | - | skills                                 |
|                    | - | time                                   |
|                    | - | community organizations                |
|                    | - | government support officers (e.g EHOs) |
|                    |   |  |
| physical resources | - | water supply facilities                |
|                    | - | sanitation facilities                  |
|                    | - | health care facilities                 |
|                    | - | water storage containers               |
|                    | - | physical space to build latrines, etc. |
|                    | - | community centers / offices            |
|                    |   |  |
| economic resources | - | money                                  |
|                    | - | loan facilities                        |
|                    | - | accounting systems                     |
|                    | - | related business enterprises           |

The enabling factors may govern the major focus of the education programme if the particular target behaviours are as a result of a lack of resources. It is unrealistic to expect people to adapt their behaviours if resources and skills are lacking. However the creation of these resources could become a focus of the particular water supply or sanitation project.

Reinforcing factors are those aspects which help to affirm certain behaviours. These are normally in the form of a significant person or group of persons who by their example and words encourage or discourage certain behaviours.

In selecting which factors are to be addressed in the health education programme, similar criteria as those used to select the target behaviours can be used, i.e. level of importance and a measure of changeability.

### 3.4 Phase 4: Health education plan

At this stage a health education strategy and plan can be developed. A plan of action must be formulated to address the predisposing, reinforcing and enabling factors which influence behaviours. This plan should include a combination of educational methods and materials selected with participation from the community representatives. The plan must also include manpower, budget and time allocations.

#### 4. STAGES OF THE HEALTH EDUCATION PROGRAMME

Health and hygiene education can be linked to a water supply or sanitation project, or could be delivered with the aim of improving health in the community without the development of any additional infrastructure. Although the approach may be different depending on the related activities and purpose, the following step-by-step approach to the implementation of a health education programme can be used as a guide and check-list in any situation.

##### STEP 1: Formulation of aims and objectives

###### *Purpose*

In this initial step the aims of the programme must be discussed, clarified and agreed by the role players and key stakeholders. These should be made as specific as possible as in the example in appendix 1. These will be used to properly plan the process and ensure that the optimum process and outcomes are adopted.

###### *Who should be involved?*

To the extent possible, the following persons should be involved in this step:

- community representatives (e.g. health group);
- project or programme implementing agent;
- district and regional environmental health officers;
- nurse from local clinic or hospital;
- local government representative;
- training agent responsible for programme;
- district or regional water supply authority.

The criteria for including a person or organisation is that such person either has a good knowledge and understanding of the health situation within the communities, or will be part of the resource team designing strategies to address the health concerns.

###### *Desired output*

The desired output is a list of explicit aims and objectives which are potentially realisable and hold at least some of the common values of the community. The aims and objectives should be “owned” by all members of the team involved.

**STEP 2: Planning***Purpose*

In this phase the main role players plan the project outline and allocate responsibilities to the different primary role players. Note that this is not the detailed planning of the education programme which occurs once the specific target factors have been identified, but the overall planning to commit role players to the process and agree on responsibilities and the process to be adopted.

*Who should be involved?*

The primary people involved in planning are the persons representing organisations who will actually execute the programme or be responsible for providing resources for the programme. Other persons can be involved on an advisory basis, but not so as to make decisions for which they are not ultimately responsible.

*Desired output*

The output of the planning process should be a statement of what will be done, how it will be done, what resources are required and a programme of activities within a specified time frame. Responsibilities should also be clearly stated, and the means by which the process will be managed and monitored.

**STEP 3: Assessment of existing situation***Purpose*

Field work, research and a literature review must be commissioned to establish what the present situation is regarding health practices in the communities. Many research reports at universities and colleges would have information of health statistics, social practices and institutional structures of communities within a region. However, such information must be validated with on-the-ground surveys.

*Who should be involved?*

The main role players in this step will be a survey team comprising community members, social experts in community dynamics, technical experts in water supply and sanitation, and district officers of water and health departments who are dedicated to health promotion.

*Desired output*

The output of this step should be a list of infrastructure, related community behaviour patterns, social and institutional indicators, health parameters, and resources within the target communities. Appendix 3 lists topics which could be of importance in this step.

**STEP 4: Analysis of information***Purpose*

The information from the assessment of the existing situation is now analysed according to the process as described in Section 3: Health and Hygiene Education Planning. It is important to maintain the participation of the community members who had helped with the assessment during this analysis step. The purpose of this step is to identify and prioritise the most important factors which must be addressed by the health and hygiene education programme, and the available resources which can be utilised.

*Who should be involved?*

The analysis should be carried out by the team who undertook the planning stage, but with the possible support of organisations skilled in data and information analysis.

*Desired output*

The output of this step is a priority list of actions to be addressed by the programme, and the resources required to carry these out. This list must be accepted by the planning team and particularly the community representatives.

## STEP 5 Implementation Plan

### *Purpose*

At this step a coordinated plan to address the identified important factors is formulated. This plan sets out a programme of activities with required resource inputs in order to achieve the objectives of the programme.

The plan will normally involve a multi-faceted approach, including:

- education and awareness programmes at various levels;
- projects to improve water supply, sanitation and health care facilities;
- training programmes to develop skills;
- a financial plan and budget; and
- a plan of coordination between role players.

The limitations and possible hindrances to the implementation of the plan should also be considered and contingency plans formulated where deemed necessary.

### *Who should be involved?*

As with the analysis, planning should be carried out by the organisations with the specific responsibility for implementation, but in a participatory way with community representatives. District and regional role players should be requested to participate or at least endorse the plan.

### *Desired output*

The output of this more detailed planning process should, as with the initial plan, consist of a statement of what will be done, how it will be done, what resources will be required. The implementation programme must be specific listing the implementation activities and their time frame. As with the overall plan, responsibilities should also be clearly stated, and the means by which the process will be managed and monitored.

## STEP 6 Implementation

### *Description and purpose*

Once the implementation plan has been approved and resources have been made available for the implementation (including financial, commitment of role players, and the procurement or development of required skills) the programme can be implemented. Implementation of health education and awareness programmes should not be considered as a short term intervention, but rather as a longer, reinforced programme of awareness creation, promotion of better practices, and construction of sanitary and health care facilities.

Health education programmes may involve a variety of educational and promotional activities including drama, posters, demonstration facilities (e.g. latrines, hand washing installations, food and water storage methods, and water collection points), general awareness teaching programmes, and the promotion of incentives. More specific examples can be found widely in the literature. Some of these references are listed in appendix 1. Usually a mix of approaches which repeat the basic messages in different formats is considered to be more successful.

### *Who should be involved?*

Clearly the trainers and organisations responsible for delivering the programmes will be involved in the implementation. However in addition it will be important to secure the active support and promotion of key community members and other prominent local people. The implementing agent should also be involved in monitoring and evaluating the process at regular time periods.

### *Desired output*

The desired output of this step is a series of activities within the community which strongly promotes behaviours and commitment to programmes which will reduce water and sanitation related diseases within the community and improve the quality of life. The outcome should be that a wide representation of community members have been influenced by the programme and are committed to improved health practices at a household and community level.

## STEP 7      **Monitoring and Evaluation**

### *Description and purpose*

Monitoring and evaluation are useful tools to improve programme management and performance. This is all the more important in health and hygiene education programmes where the emphasis is on changing behaviour of people. Monitoring and evaluation provide feedback to take immediate corrective steps where necessary, but also to provide longer term learning for future planning and implementation of programmes. It is important to monitor and measure both the outputs (behaviour change) and the inputs (resources and incentives).

A useful tool in monitoring programmes is the selection of indicators and setting standards. By selecting these early in the programme, the information needed for monitoring can be more precisely specified and the monitoring programme can be concisely designed. In community water supply and sanitation programmes, monitoring should be focused on the following related fields:

progress in relation to the work plan;  
participation of the target population; and  
adaptations and changes in conditions and behaviour.

### *Who should be involved?*

The implementing agent is primarily responsible for monitoring and evaluation. However the whole project team as described above should be involved. Information will need to be collected and provided by almost all team members, and the results will be of benefit to all of them.

### *Desired output*

The desired output of monitoring and evaluation is a continuously improved management process, and practical lessons for future similar or related projects.

## 5. CONCLUSION AND GENERAL

Health and hygiene education is an important aspect of water supply and sanitation projects, ensuring real health benefits from the projects. It is important to note, however, that no assumption is made that rural or developing communities are unaware of hygiene practices and the need to control the spread of diseases. Rather this programme is based on the fact that certain knowledge and health behaviours are being practised in these communities, but circumstances have resulted in new conditions for the transmission of disease. Health and hygiene education is then to create an awareness of these conditions, and to offer methods for combatting these at a local or household level.

In this process the specific role of women must be acknowledged and women must be encouraged and persuaded to take a leading role in bringing about behaviour changes in communities. Women should make up a significant portion of the health education programme team.

Finally it is the aim of this guide that health education programmes will not be considered as simply a programme of telling communities what they are doing wrong and why they should change, but rather an interactive process between implementing agents and communities to identify and address the most important health factors in the community. These factors are then addressed within a programme of information sharing where the dignity of communities is preserved.



## APPENDIX 1

## USEFUL REFERENCES FOR FURTHER READING

- IRC, 1985. Making the links: Guidelines for hygiene education in community WS&S. OP5-E, 82 pp.
- IRC, 1988. WS&S in primary school education in developing countries. 47 pp.
- IRC, 1993. Actions speak: The study of hygiene behaviour in WS&S projects. AS-E, 150 pp.
- IRC, 1991. Just stir gently: The way to mix hygiene education with WS&S. TP29-E, 182 pp.
- WASH, 1987. Guidelines for designing a hygiene education programme in WS&S for regional/district level personnel. Field Report No.218. Yaccoob and Simpson-Herbert.
- Water Research Commission, December 1993. Environmental Impact of On-site sanitation: A literature review with particular application to South Africa. WRC Report No. KV 57/94. KB Fourie and MB van Ryneveld, University of the Witwatersrand.
- Water Research Commission, April 1995. Review of rural sanitation in South Africa. WRC Report No. KV71/95. Palmer development Group, 100 pp.

**APPENDIX 2:**  
**Range of possible useful social and health information**

1. *Demography*
  - population size, density, growth rate, mobility (males, females);
  - population groups (social, economic, ethnic, religious);
  - household size and composition (special features such as women heads of households, multi-family households);
  - division of tasks and responsibilities in households, role of women.
  
2. *Housing*
  - settlement structure;
  - types of houses, their physical condition and layout;
  - types of building materials used;
  - space available inside and outside the house;
  - in-house water and sanitation facilities.
  
3. *Physical infrastructure*
  - road, road conditions / public transport;
  - primary school for girls / boys, secondary school for girls / boys;
  - primary health care centre, health clinic;
  - shops, market, post office;
  - religious centres (mosque, church, temple), community centres;
  - small scale industries, industrial plants;
  - water supply and sanitation facilities (public, private);
  - needs / obstacles to improve present facilities.
  
4. *Health*
  - major health problems and relative importance of water and sanitation-related diseases (related to gender, age and socio-economic groups);
  - seasonal variations;
  - knowledge and perceptions about diseases and health (related to gender, age and socio-economic groups);
  - use of government and non-government health services (related to gender, age and socio-economic groups);
  - availability of health personnel (gender, level of education and training);
  - ongoing formal and informal health education activities; target groups;
  - specific environmental health dangers.
  
5. *Water availability*
  - water source(s), water point(s), distance, accessibility, reliability, quantity, quality (related to socio-economic characteristics);
  - seasonal variations;
  - cost of water, water vending;
  - protective measures / health risks at water sources / points;
  - water rights and water source management.

6. *Water use practices (related to gender, age and socio-economic groups)*
  - preferred sources of water by purposes;
  - water collection, transport and storage practices;
  - personal and domestic use of water (drinking, hand washing, bathing, clothes washing, dish washing, vegetable washing, cleaning, anal cleansing);
  - water use for animals, gardening and other productive activities;
  - quantity of water by purpose, reuse of water;
  - criteria applied to decide on suitability of water for different purposes;
  
  - obstacles to adoption of improved practices.
  
7. *Sanitation practices (related to gender, age and socio-economic groups)*
  - existing defecation practices;
  - cleansing and ablution materials and practices (also prevalence of bathing in latrines);
  - belief and restrictions related to latrine use (eg. Location, sharing);
  - latrine cleaning and maintenance practices;
  - latrine emptying and sludge reuse practices;
  - wastewater and solid waste disposal practices;
  - food storage, handling and preparation practices;
  - household / kitchen hygiene;
  - availability and use of soap for personal hygiene;
  - obstacles to adoption of improved practices.
  
8. *Occupation*
  - major occupations and approximate distribution (males, females);
  - seasonality of employment.
  
9. *Organization and participation*
  - local organizations and type of membership;
  - local leaders (males, females) and leadership structures, local decision-making;
  - informal leaders and key-persons (males, females);
  - major local political or social factors which might affect participation;
  - previous interest and participation in water and sanitation or other development activities (related to gender, age and socio-economic characteristics);
  - important characteristics that would determine the acceptability of outsiders working on projects in the area;
  - local traditions and practices for operation, maintenance and repair of water supply, sanitation and other structures.
  
10. *Level of interest*
  - evidence of popular interest (males, females) in improving water supply and sanitation, compared to other potential improvements in the community;
  - evidence of leadership commitment to improvements;
  - evidence of equal access to project resources and activities.

11. *Willingness and ability to pay (related to gender and socio-economic characteristics)*
  - ownership of land, house, personal property;
  - income;
  - expenditure patterns;
  - borrowing and saving customs.
  
12. *Local technology and resource availability*
  - local availability of building materials;
  - availability of skilled and unskilled labour (males, females, noting seasonal variations);
  - availability of technology-related inputs (such as water for pour-flush latrines).
  
13. *Education and communication (related to gender and socio-economic characteristics)*
  - education and literacy levels;
  - numbers of school-going children (boys, girls), dropouts;
  - numbers of teachers, level of education and training;
  - adult education and vocational training;
  - availability and relative importance of communication channels (from mouth-to-mouth to television)

Adapted from: World Neighbours in Action, "Communication" in: Favin et al (1986) p. 20/21.

# **WATER RESEARCH COMMISSION**

**A GUIDE TO:**

## **SPRINGS AND SPRING PROTECTION**

**PREPARED BY**

**DIVISION OF WATER, ENVIRONMENT AND FORESTRY  
TECHNOLOGY, CSIR**

## TABLE OF CONTENTS

TABLE OF CONTENTS .....	ii
LIST OF ILLUSTRATIONS .....	iii
1. INTRODUCTION.....	1
2. AIM OF THIS DOCUMENT .....	1
3. OBJECTIVES OF COMMUNITY WATER SUPPLY IMPROVEMENT .....	1
5. GROUNDWATER.....	5
6. WHAT IS A SPRING?.....	8
7. TYPES OF SPRINGS .....	8
7.1 Gravity springs.....	8
7.2 Artesian springs.....	15
7.3 Karst springs .....	20
8. SPRING WATER QUALITY .....	23
9. SELECTING A SPRING FOR USE IN COMMUNITY WATER SUPPLY .....	24
9.1 Community involvement and participation .....	24
9.2 Inspection of the spring .....	24
10. DEVELOPMENT OF SPRING SOURCE FOR USE IN WATER SUPPLIES ....	25
10.1 General.....	25
10.2 Preparation of the site .....	26
10.3 Retaining wall structure.....	26
10.4 Spring tapping by drains .....	28
10.5 Spring boxes.....	31
10.6 Spring tapping by tunnels.....	40
10.6 Sanitary protection of springs.....	42
11. UTILISATION AND MAINTENANCE OF SPRING-BASED GROUND WATER SUPPLY SYSTEM.....	45
12. REFERENCES .....	46

## LIST OF ILLUSTRATIONS

Hydrological cycle	4
Groundwater occurrence and movement	6
Multiple seeps	8
Wetland seepage	8
Sedimentary bedding plane	9
Soil/Rock contact	9
Sill contact	9
Dyke contact	9
Fractured lithological contact spring on a fault	9
Artesian fissure spring	10
Artesian overflow spring	10
Karst overlies permeable rocks	12
Karst overlies impermeable	12
Retaining wall structure	17
Spring tapping by drains	18
Typical spring box	19
Vee box	20
Spring box over small fissure spring	20
Spring box over artesian spring	21
Tunnel for spring tapping	21

## **1. INTRODUCTION**

Water is one of our most critical natural resources. It is essential for life as drinking water and is an essential ingredient in the production, processing and preparation of food. For that reason, it is almost trite to say that all communities must have access to some kind of water source. Water is required for consumption, for personal hygiene, for production of crops and goods, and for recreation. Water is central to development, and is required for survival, public health and economic development.

However, the provision of access to an adequate supply of water to all people, defined in terms of water quality, quantity and distance to the supply, is still in the developmental stages in many countries, including South Africa. It is estimated that in South Africa, more than 10 million people do not have access to an adequate supply of potable water and nearly 20 million people lack basic sanitation.

Rural communities collect water from existing sources close to their homes. In many parts of the country this will often be a spring, which, though not protected, will have supplied water to a number of families for many decades. This spring water is usually the water of choice because it is cleaner than water from the streams, and usually tastes better than water from other sources. However even though springs come from an underground source of pure clean water, spring water often becomes contaminated once it comes out of the ground, or just before it comes out of the ground. This contamination may be from cattle or other livestock, poor sanitation practices, or from other natural activities within the spring zone.

The lack of adequate and safe water supply and sanitation for many rural communities has had a major impact on the health and productivity of these communities. Springs often offer a low cost option for providing such communities with a safer and more reliable water supply than many other more expensive options. With some modifications to the spring outlet, and the provision of a storage reservoir to collect water continuously from the spring, springs can meet many of the requirements of an adequate water supply to a rural community.

## **2. AIM OF THIS DOCUMENT**

This document is written to assist decision makers and implementing agents actively involved in the field of community water supply and sanitation in deciding whether to go for the option of developing a water supply based on spring sources. The document does not argue the merits of one supply option against any others. It is recognised that the circumstances of each different locality may require a different option. What this document aims to do is to provide information for cases in which the protected spring option has merit. The document is structured so as to introduce the hydrological cycle, which influences all water sources, explain how springs occur, where to find them, how to identify them, and methods of protecting spring sources to be used in water supplies.

Engineers and technicians who are responsible for developing water supplies will find this document useful in providing background information. However, most of the concepts and ideas presented are for the requirements of planning. This document does not give detail engineering design or construction techniques. In this document, no attempt will be made to distinguish between 'spring tapping' 'spring development' and 'spring protection', and the term 'spring protection' shall be used to describe any or all of the processes.



### **3. OBJECTIVES OF COMMUNITY WATER SUPPLY IMPROVEMENT**

The aim of water supply improvement is to provide safe drinking water, primarily for life sustenance. Safe water also plays a major role in improved health of communities and improved quality of life. According to the RDP, the minimum requirement for drinking and other household uses such as cooking, washing dishes, and so forth is 20 to 30 litres per person per day. In planning improved water supplies to meet this basic demand, one must ensure that the development takes place in a sustainable manner and at a price that communities can afford.

The question of affordability is critical in community water supplies since affordability influences sustainability, and helps to ensure that people do not return to unsafe traditional sources. A scheme which the community cannot afford to maintain is doomed to fail. Thus, the water-supply solution to be chosen for any community should maximise use of local labour and material resources. It must also result in a supply that requires minimum or no water treatment, and put in place a system that functions well with minimum operation and maintenance costs. The technology chosen should ideally allow the maximisation of community involvement in the development, operation and maintenance to make it affordable and sustainable.

The choice of water source for community water supplies must be based on reliability, quality and quantity of water. Where rivers are available, communities can be supplied from surface water sources through the construction of small dams or weirs, assuming suitable sites. Such a supply would require treatment works to ensure maximum health benefits. In addition, moving the water closer to the people through a reticulation system which includes treated water storage facilities will probably be necessary. However, one must take into account that most rural communities are small and often lack the capacity to pay for the maintenance of such a system.

Groundwater can provide a water supply system through boreholes that is much less costly than surface-water-based systems. The capital cost is much lower. Ground water seldom needs treatment, thereby eliminating one of the major cost components of a surface-water-based system. Additionally, it is sometimes possible to eliminate the main operation and maintenance costs of a groundwater-based system. These costs mainly relate to fuel, pumping plant, reticulation and storage infrastructure. They can be eliminated by using alternative technologies such as hand pumps, hand-dug wells, etc. especially when the supply is for small to medium sized communities.

Groundwater can also be provided through springs. Springs have been used as water supply sources for generations. Even today many communities or individual homesteads rely on unprotected springs. However, most uses of spring water do not recognise the possibility that the spring water may be contaminated. In the past no problems were ever experienced with the springs, so why should we now be concerned? The increase in population density in most rural areas has sometimes led to dwellings, toilets, rubbish dumps, livestock pens, etc. being constructed too close to the springs, resulting in a high risk of contamination of the springs. This factor means that spring waters cannot be considered safe without a proper assessment and spring protection precautions being taken.

In spite of the need for spring protection, springs have the following advantages:

- ▶ They require minimum to no treatment if they have adequate sanitary protection.
- ▶ Since most springs are found in the hills or high slopes, water can often be piped under gravity to the community, requiring no external energy source and no pump maintenance programmes.
- ▶ Operation and maintenance costs are lower.
- ▶ The local community can be trained to manage the water supply system without any support from external contractors.

Finally, in opting to meet the community's water needs from spring sources, one must ensure as far as practically possible that the source is reliable; that the quantity of water obtainable from it will be sufficient to meet the basic needs of the community; and that the quality of the water is of acceptable standards for human consumption. This document is intended to assist planners, developers and users of springs to understand spring-water resources and to be able to answer these questions.

#### 4. The Hydrological cycle and global water balance

In order to gain a proper understanding of springs, it is important to first look briefly at the place of groundwater in nature. The water on earth, is stored as water vapour in the atmosphere, as surface water in rivers, streams, lakes, seas and oceans, or as ground water underground below the land surface. This water is for the most part not at rest but in a state of continuous cyclic movement. This is called the hydrological cycle. The movement of water in nature at any part of the cycle is a complicated process and this document intentionally gives only a simplified, but relevant overview.

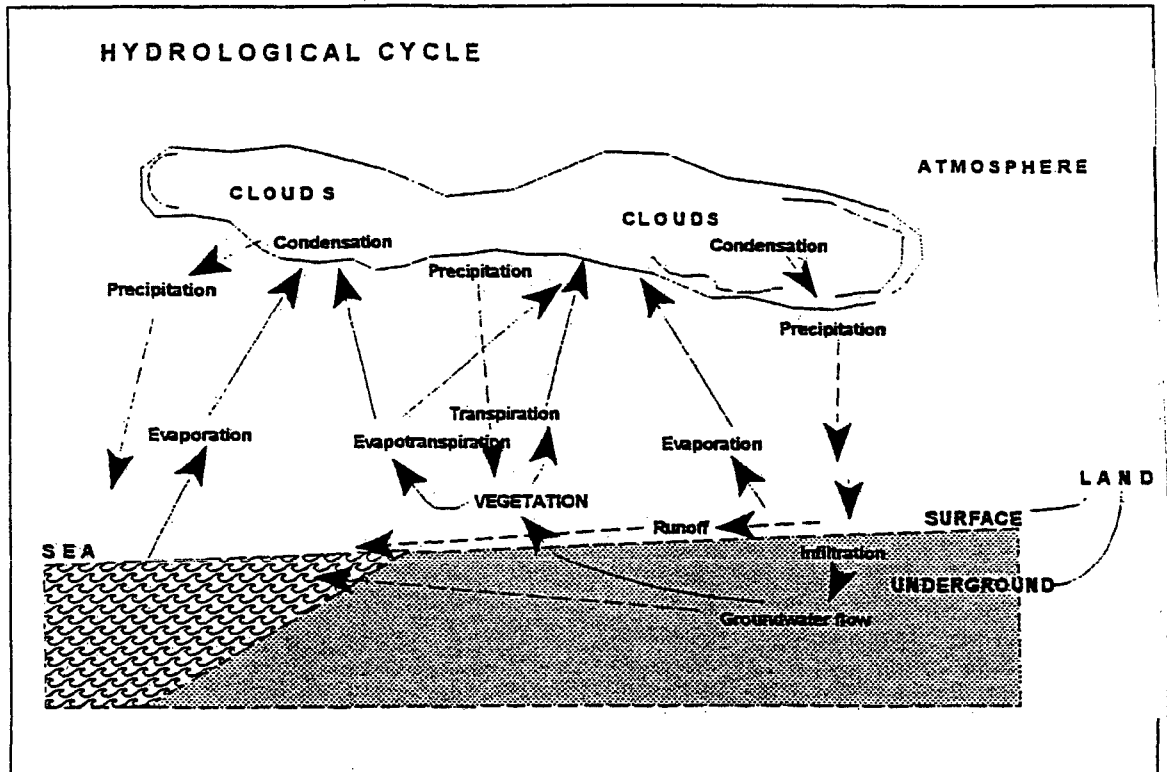

Water vapour in the atmosphere condenses into ice crystals or water droplets forming clouds. When the crystals and droplets become too large to remain in suspension as cloud particles they fall to the ground as precipitation such as rain, hail or snow. Plants, trees and buildings intercept part of the precipitation, and some is detained in pools and puddles on impervious and impermeable surfaces. This portion evaporates and returns into the atmosphere where it will once more condense and form clouds when energy balance conditions are favourable.

The largest portion flows along the ground until it forms streams and rivers as runoff that flows into lakes or seas and oceans. Evaporation takes place from the surfaces of rivers, lakes seas and oceans, taking some of their waters back into the atmosphere.

The remaining fraction infiltrates into the ground and seeps downwards. Some of this is absorbed by roots of plants and released back to the atmosphere through evapotranspiration. Some of this infiltration water is retained in the upper soil as soil moisture, while another portion is drawn back to the surface by capillarity action and may be released to the atmosphere through evapotranspiration. If there was heavy infiltration or the soil moisture

content becomes too high, the excess of infiltrated water percolates further down into the underlying rock to occupy spaces between the rock particles (in the case of a porous rock) or occupy fractures, joints and other weak zones in the rock. This is the water known as groundwater. In some areas, direct infiltration of water from rivers and lakes into the underlying rock may also occur in a process known as natural groundwater recharge. Groundwater flows underground following the pressure gradient or water table until some of it returns to the land surface through springs, seepage to streams as base flow, or direct subsurface seepage to lakes, seas and oceans where it rejoins the water cycle anew through evaporation.

The quantity of each fraction in the above cycle depends on several factors including:

- ▶ The intensity and duration of precipitation
- ▶ The density and distribution of plant and tree cover
- ▶ The soil type and prior or antecedent soil moisture content
- ▶ The slope of the land and thickness of pervious and permeable soils and rock
- ▶ The type and area of exposed rock or rock under the soil cover.

Water and Climate scientists often estimate elements of the hydrological cycle to obtain an approximate global water balance. They generally estimate that nearly 75% of the fresh water on earth is stored as ice in the polar ice caps, icebergs, peaks of mountains, and so on. The remaining 25% consists of 24% stored as groundwater, and 1% circulating as surface and atmospheric water. This percentage distribution differs on a local or regional scale, being mainly controlled by solar energy balances, the geological environment, and other variables. The figures show in a general way that groundwater is the largest source of fresh water in storage on our planet; although its occurrence in many parts of the world varies greatly in line with the distribution of suitable water-bearing rocks (aquifers). Thus, although South Africa is not endowed with vast highly porous aquifers, the vital importance of groundwater as a resource for fresh water supplies cannot be underestimated.

*Groundwater is a particularly important source of fresh water supply in South Africa where most areas are either arid or semi-arid with few perennial rivers. Even in the wetter areas of the country, groundwater acquires added importance in times of drought when many of the surface resources dry up. In addition, many communities can only be served from groundwater resources. This is because there are often too few families to justify the costs of construction, operation and maintenance of dams and/or treatment works. It may also be that there are no suitable dam sites nearby. In such cases, the communities often have to rely on ground water supplied through boreholes, wells or springs.*

## **5. GROUNDWATER**

There are many misunderstandings, misconceptions and half-truths about groundwater. One example is the half-truth that groundwater moves in underground rivers similar to surface rivers. This condition only occurs in some large dolomite caves and cavities. Another example is the misconception that there is enough useable groundwater everywhere below the surface of the earth, if one only drills "deep enough". A lot of dry holes, many of them deeper than 100 metres have been drilled in different geological environments throughout the country. It is also not true that groundwater is always 'pure'. Many potentially harmful substances such as pesticides, sewage effluent, spilt oil, etc. can migrate into groundwater through seepage and pollute the water.

The paragraphs below briefly summarise the main elements of ground water occurrence and movement below the ground surface.

The portion of water that infiltrates into the ground continues to move downwards under force of gravity until it reaches the top surface of the "saturated zone" or, if the rock is not already saturated, an impervious rock horizon. The top surface of the saturated zone is known as the water-table. From the water-table downwards, the direction of groundwater flow changes from being dominantly downwards to being mainly horizontal in the direction of the downward slope of the water-table.

Meanwhile, some of the percolating water may be held in the pore spaces between soil particles or rock particles by capillary and/or molecular forces. Some of this water may be used by plants or evaporate directly, while some remains in the soil as soil moisture or is retained in the regolith below that by capillary forces. The rest of the water continues to flow predominantly downwards, following the path of least resistance until it either escapes to open water-courses at a shallow depth, or reaches the deeper groundwater body. The deep groundwater is not stagnant unless it is held in horizontally isolated rock interstices (pores). It flows mainly horizontally in the direction of the slope of the water-table or towards lower pressure zones. Most of the flow takes place through interconnected cracks (fractures) and openings (fissures), with some flow occurring also through linked pores. At some point this groundwater emerges to the surface, either as a spring or as an outflow into a river, sea or lake. The diagram below illustrates groundwater occurrence and movement.

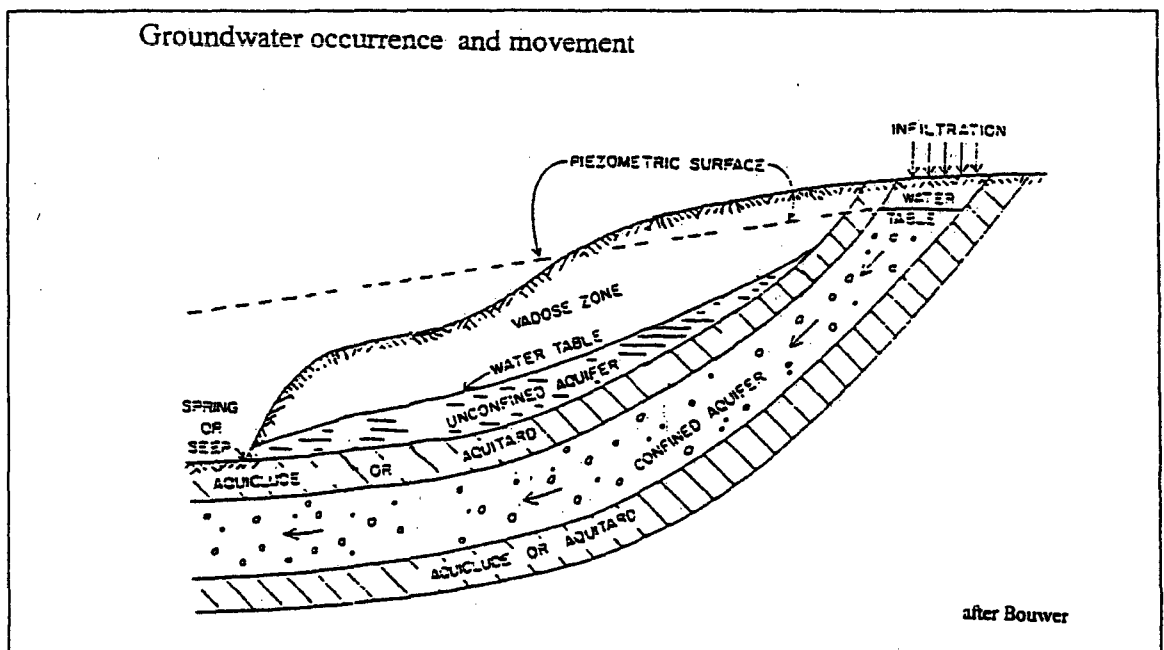

The flow within an aquifer below an impervious stratum can be either confined or unconfined. When the groundwater level is free to rise and fall, flow is unconfined or free. The top surface of an unconfined water body is called the water-table. The water pressure at the water-table is equivalent to the atmospheric pressure at that surface. On a macro level, groundwater flow in this situation is predominantly gravity flow.

If the aquifer underlies an impervious stratum, flow is confined, which is similar to flow of

water in a pipe under pressure. In this case, a water-table does not exist. The water pressure at the top of such a water body is greater than the atmospheric pressure. On a macro level, groundwater flow in this situation is predominantly artesian flow. If a well is dug or borehole drilled such that it penetrates the impervious stratum into the aquifer below, the water level in the hole will rise to a level equivalent to the water-table. This level is known as the piezometric level. When the piezometric surface is above ground level, water flows freely out of the well and the well is known as an artesian well.

Sometimes water finds a natural outlet through a natural breach in the impervious layer such as a fracture or change in rock composition and pore-space distribution which renders it permeable. This water may reach the surface as an artesian spring; one of the spring types described later in this document.

## **6. WHAT IS A SPRING?**

A spring is a place where water flows out naturally from below the ground. The water may flow out through a single point, known as the "eye" of the spring, or may come to the surface through several contiguous eyes opening into the same wetland "seep", or over a relatively wide discontinuous area as multiple seep springs or even lineally strung out eyes as a "spring line". The rate at which the water comes out of the ground also differs. It may seep to the surface relatively slowly or may stream out strongly. Springs do not only emerge at ground surface as an outflow of groundwater, but can also occur under water into rivers, lakes or even the sea.

Where this water emerges in the form of a spring, it can be easily tapped. In some parts of the country, such as South Africa's southeast coast, people have traditionally relied on natural springs for their water supply. In other parts of the world, the oldest community water supplies were often based on springs. Some urban communities in North America still obtain their water supplies from springs.

Springs are found mainly in mountainous or hilly terrain, usually fed from sand or gravel aquifers or from secondary aquifers consisting of water flowing through fissured rock, along sedimentary rock bedding planes, or along fractures, faults, and fractured rock contact zones.

Springs are generally a result of groundwater flow coming against an impermeable barrier such as clay layers or impervious rocks. These barriers block the flow of underground water, which is then forced along the path of least resistance and can come to the surface. The water may emerge either in the open as a spring or invisibly as an outflow into a river, stream, lake or sea. Differences in the manner in which the water is forced to surface, and the topography of the terrain in which this occurs, lead to different types of springs.

## **7 TYPES OF SPRINGS**

Springs can be classified in different ways. The simplest is to divide the springs into two main types based on the dominant macro groundwater flow type - gravity springs and artesian springs. Then there is the special case of springs emanating from carbonate rock aquifers.

## 7.1 Gravity springs

Gravity springs occur where groundwater emerges at the surface because an impervious layer prevents it seeping downwards. This type usually occurs on sloping ground, although it can also be found in areas that seem to be flat to the eye. Typically, its flow changes with variations in the height of the water table.

Gravity springs can be further subdivided into *gravity depression springs* and *gravity overflow springs*.

Gravity depression springs occur where the ground surface dips below the water table. Any such depression will be filled with water. An example of this type is the small to medium wetland seepages that are usually seen in flat to nearly flat areas where shallow permeable soil overlies clay or impermeable bedrock. The seeps occur at the sides of the depression in horseshoe or semi-circular fashion. Sometimes the multiple seeps do not constitute one spring. Depression springs often have a small yield, which is further reduced during the dry season and if nearby groundwater withdrawals result in lowering of the local water-table.

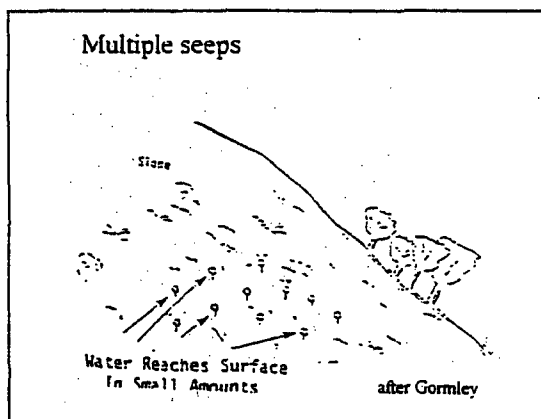
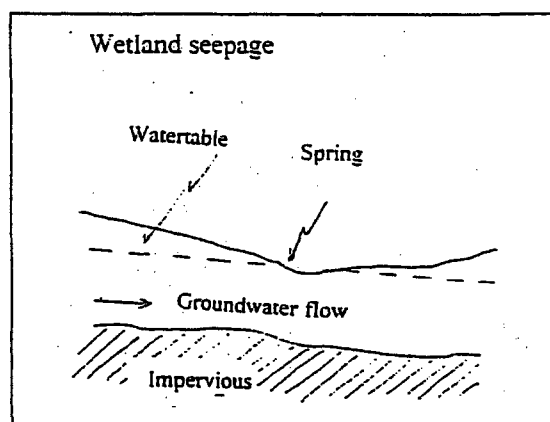

Gravity overflow springs, the second sub-type, occur where an outcrop of impervious material, such as a clay horizon, prevents further downward flow of subsurface water and forces it up to the ground surface. The soil/rock contact where soils meet fresh unweathered bedrock at sloping ground surface, thereby forcing the water table to intersect the ground surface is an example of these springs. Similar spring types occur at the contact between water bearing porous rock and impervious rock, or where very weathered rock grades into unweathered rock. Conditions where flow along horizontal or near-horizontal sedimentary bedding planes exits at ground surface provide another example.

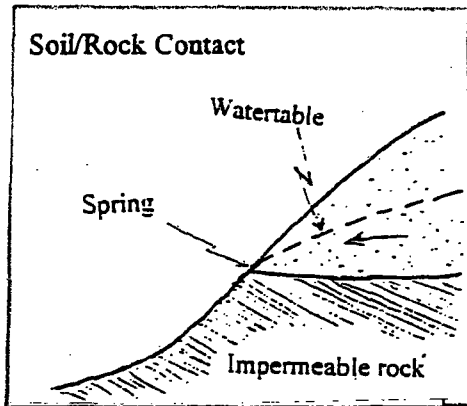
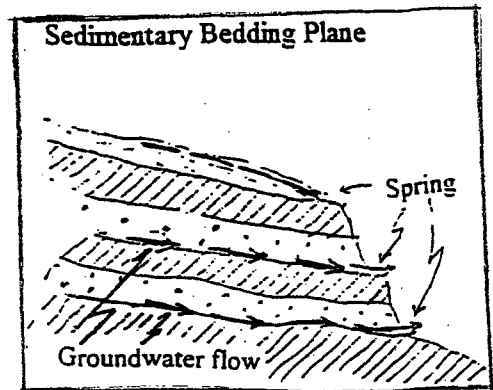

Other gravity overflow springs occur at dyke contacts, sill contacts and at fractured lithological contacts. Gravity overflow springs offer much larger and less variable yield than gravity depression springs. However, fluctuation may occur in periods of drought, with the possibility of springs drying up. In addition, they are affected by groundwater abstraction in exactly the same way as the depression springs. Generally, the flow from most gravity depression springs and gravity overflow springs can be increased by appropriate excavation and flow interception structures. Sill contact springs, dyke contact springs, and

Position of spring outlet depends on whether or not sill is more permeable than surrounding rock

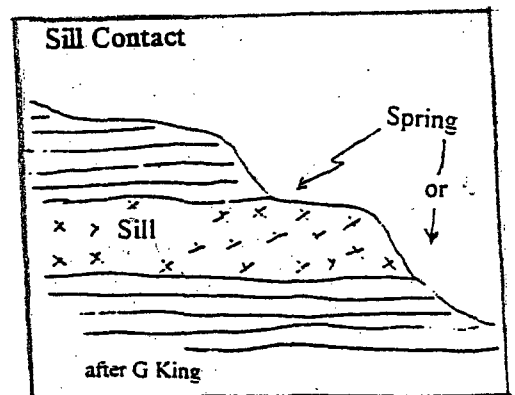

fractured/faulted lithological contact springs are illustrated below.



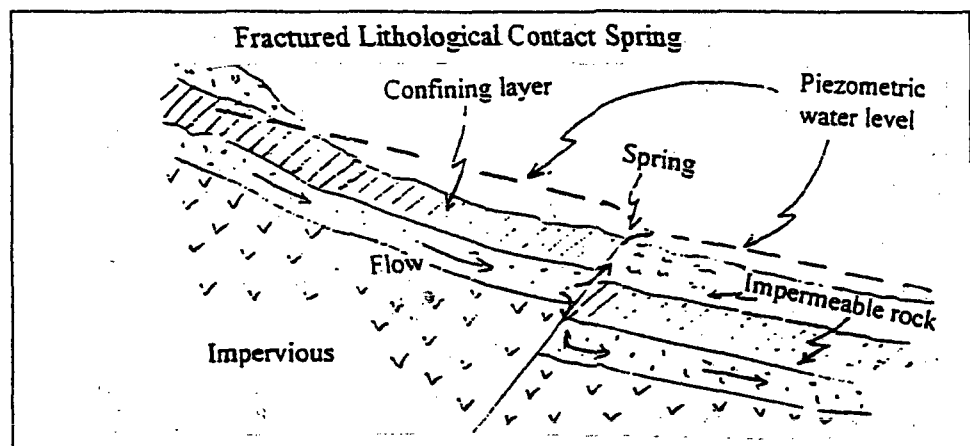
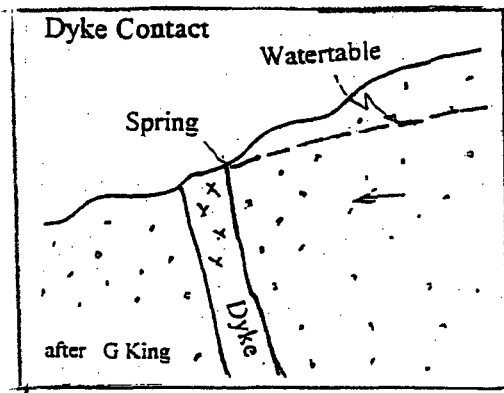

## 7.2 Artesian springs

Artesian springs comprise the second major grouping of springs. These occur where groundwater emerges at the surface after confinement between two impervious layers of rock. A fault or fissure in the overlying impervious layer or some other natural breach in the impervious layer such as a change in rock composition and pore-space distribution which renders it permeable may provide an outlet to the surface as an artesian spring. A spring of this type is likely to be very uniform in yield and flow is very nearly constant in spite of seasonal variation in rainfall and evapotranspiration over the catchment.

Artesian springs can be further subdivided into *artesian depression springs* and *artesian overflow springs*.

**Artesian depression springs:** these are similar to gravity depression springs in appearance. In these springs, water is forced out under pressure so that the discharge is higher and shows less fluctuation than that at a gravity spring. A drop in the water table during dry periods has little impact on the flow of the spring. A variant of this spring type is the artesian fissure spring found in many countries. The type occurs as illustrated below.

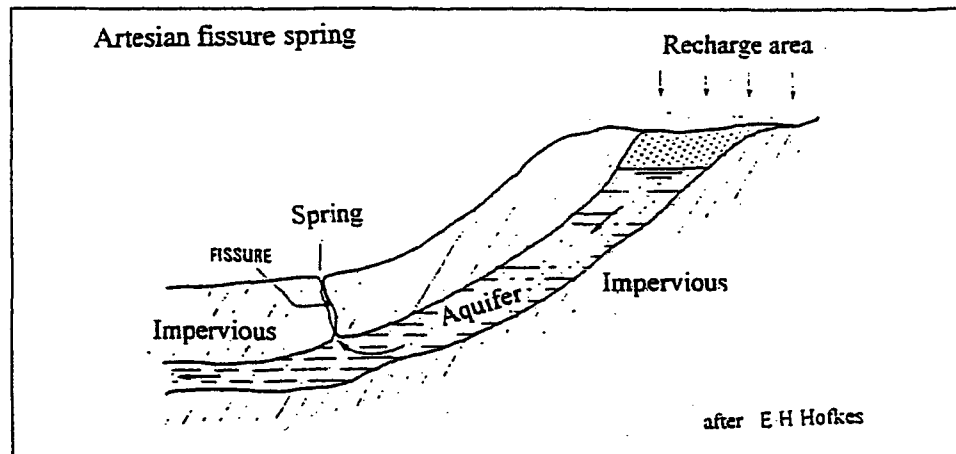

**Artesian overflow springs:** in these springs water is forced out under pressure, showing good discharge with little or no seasonal fluctuation especially where the recharge area is at a considerable distance away. Artesian overflow springs are most ideal for community water supply purposes, with the advantage of contaminant free water due to the impervious cover protecting the aquifer.

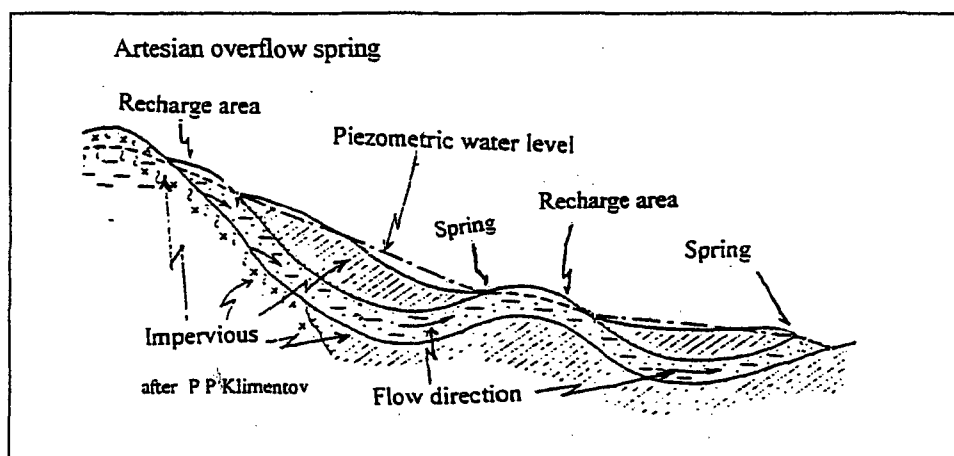

The flow from artesian springs is less influenced than gravity springs by seasonal fluctuations in rainfall, short-term droughts, and normal upstream groundwater abstraction. However, the limit of influence depends on the characteristics of the confined aquifer. The yield from an artesian spring may be increased by cleaning or enlarging the opening ("eye") in order to reduce the friction head loss. How much this measure may succeed in improving the yield will depend on the extent to which friction loss was a constraint.

Spring types can also be defined by reference to the type of opening through which spring flow occurs. Hofkes presents names given to some springs using such a classification system. These types are:

- *seepage or filtration springs*, where water percolates from many small openings in porous ground;
- *fracture springs*, where water issues from joints and fractures in solid rock;
- *tubular springs*, where openings are more or less round.

### 7.3 Karst springs

Springs in carbonate rock areas such as dolomite and limestone where karst features can develop, as well as those in other highly soluble rocks such as gypsum and anhydrite, constitute a special case known as karst springs. The well-known dolomite springs in Gauteng, North West Province, and other parts of South Africa are an example.

The hydrogeologic characteristics of karstified dolomites, limestone, or other such, are similar in some respects to those of jointed rocks. However groundwater movement in, for example, dolomite areas where karst features are well developed is more comparable to river flow than other groundwater flow. Although true springs exist in these areas, in some cases, a surface stream may disappear into a sinkhole, flow underground along channels, caves and other cavities produced by the chemical and mechanical action of water on leachable or soluble rocks, and finally emerge as a spring at a lower altitude elsewhere. This is obviously not a true spring, but it may not be possible to tell apart such springs from the true springs in the field since the course of these underground rivers may be long.

Springs in dolomite and other carbonate rock areas are dominantly overflow springs although depression springs may occasionally be found where shales overlie the dolomites. As a generalisation, springs in these areas have very high yields in the order of tens of litres per second as compared to other geological environments where average flows normally range from less than one to under ten litres per second. Yields of karst springs are characterised by strong seasonal variation with flows dropping from, say, hundreds of litres per second in wet

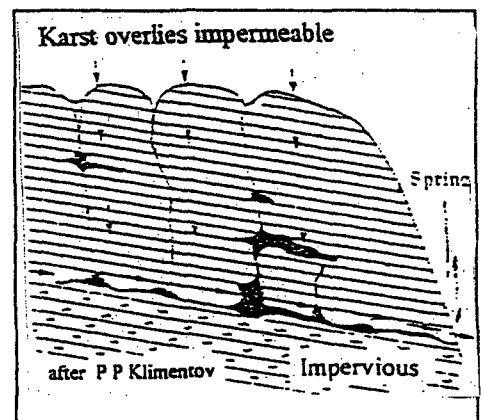
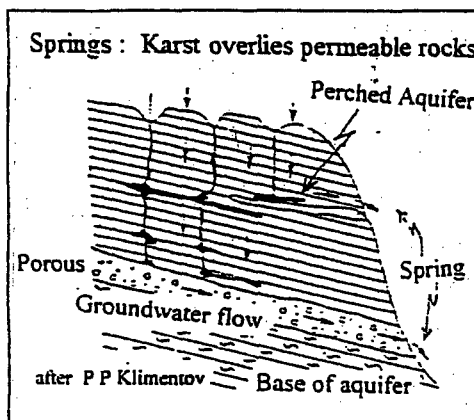

seasons/years to tens of litres per second in dry seasons or during drought.

It may be difficult if not impossible to increase the yield from karst area springs since the natural opening is in most cases already optimal for the flow conditions at that discharge point. Some small yield improvement may however be achieved through clearing the area around the "eye" by removing vegetation, soil, and rock debris. The success of this measure will depend on the extent to which the debris was constricting flow and on storage conditions in the karst. However, water quality is more important than quantity in using karst springs.

## 8 SPRING WATER QUALITY

The quality of groundwater is usually good with minimal levels of unwanted contaminants. Water percolating into the ground undergoes a process of filtration which removes fine suspended solids and bacteria and reduces the number of other harmful enteric organisms. The effectiveness of this natural filtration depends on the nature of the soil or geological material that the water is passing through as well as the size of the filtered particles or organisms. On the other hand, the percolating water may undergo a significant increase in the amounts of dissolved salts because of its contact with rocks and minerals in the earth. Spring water is conventionally seen as uncontaminated due to the fact that it is actually groundwater which has filtered out. This perception is not always true since groundwater is also subject to contamination from faecal matter, other organic wastes and inorganic solutions which may invade the system through large openings such as fissures or enter it in the vicinity of the spring outlet.

In selecting a spring for use for domestic water supply, the main water quality aspect to consider is that the spring is free from bacteriological contamination. Springs in general, and gravity springs in particular are subject to bacteriological contamination in the area close to the point of emergence. Springs emerging from limestone formations undergo very little filtration in the ground. Such springs are likely to yield grossly polluted water soon after heavy rains, and should not be used as a source of domestic supply without treatment.

It is necessary to carry out a sanitary survey as part of the process of selecting a spring for use in domestic water supplies. The first step in a sanitary survey of a spring site is to determine the physical conditions above the point where the water flows from the ground. If there are large openings or fissures in the bedrock above the spring, contamination of the spring from surface runoff may occur. The surface water enters the ground through the fissures. The sources of potential faecal contamination are;

- livestock areas,
- septic tanks and other sewage disposal sites;
- laundry and bath water disposal;
- solid waste dumps.

If the springs are located in the immediate catchment of the spring, say closer than 100m in moderate to highly permeable formations such as sand and gravels, the possibility of contamination is high.

The second step in a sanitary survey includes the study of the area at the spring site. The type of soil may indicate that contamination is likely. Filtration may be poor if permeable soil deeper than 3m is within 15m of the spring. Water passes quickly through coarse soils and impurities are not filtered out. All sanitary surveys must be supported by a water quality analysis, checking mainly for bacteria or faecal coliform contamination.

## **9. SELECTING A SPRING FOR USE IN COMMUNITY WATER SUPPLY**

### **9.1 Community involvement and participation**

The first step in selecting a spring for community water supply is to elicit the participation of the people who will be affected and those who will be the beneficiaries. Sometimes it is not the same people. As an extreme example, when water is led away to serve families further down slope who may or may not be part of the community. In this case, those in the vicinity of the spring may lose one of their water sources while those downstream will benefit. Both groups should be involved in developing the supply.

Involving the people should be more than asking them where the springs are, whether they stop flowing in the dry season and so on. It is important to find out about the flow and reliability of the springs for that is what ultimately decides the financial feasibility of protecting the spring - in terms of per capita cost. However, it is equally important to ascertain the people's attitudes to the spring protection, to explain to them the benefits, and to allow them to influence the decisions wherever possible and where their suggestions are not practical, to explain to them why. Involving the people is more than employing them to work on the project.

There may be taboos and traditions associated with certain springs in some rural communities. These will need to be respected, and, where the beliefs are an obstacle to development, appropriate education of the community will help them to accept the need for change. This education must involve the local community leadership and traditional "institutions" such as chief, rainmaker, sangoma etc. It is important to instill the correct attitudes in the community. They are the ones who are going to use the water supply and so they must take ownership of the whole process in order to assure future sustainability of the water supply. Acts of vandalism perpetrated by adults have happened in the past in some places where communities were reportedly "involved" on the projects. The people had never really accepted the project - a fact which the promoters missed because of mistaking employment without taking part in the decision making for community involvement.

*Information on the adequacy and reliability of the spring*

The second step is to gather as much information about the spring or springs with the involvement of the community. Find out the history of flow and seasonality of flow. The aim is to find out whether the flow is reliable through the different seasons, and also through drought years. Women in the community are the best source of this information since family water collection is their responsibility. Attention should be paid to spring yield. A weak spring may fail to meet the demand and cause a serious loss of faith in spring-water supplies among the community members. Investigate the possibility of linking up separate contiguous springs if this will improve yield. If not, it may be more advisable to opt for hand-dug wells fitted with hand pumps or other supply options.

### **9.2 Inspection of the spring**

The next step should be to visit the spring. Measure the yield of the spring. It is always best to measure a spring during or preferably near the end of a dry period, as this will indicate the reliable yield of the spring. The flow should be measured to ascertain whether it is going to be adequate to meet the demand. For example, using the RDP figures, and without

considering storage facilities, a flow of 0.1 l/s will provide peak hour demand for only two to three families while 1 l/s will provide peak hour demand for about 20 to 50 families. Installing spring water storage facilities to collect water during periods when people are not collecting water, however, considerably increases the number of families served. In the above example, a flow of 0.1 l/s will provide enough water for up to 35 families, while 1 l/s will provide enough water for up to 350 families.

Other questions to answer include, what storage facilities will be needed? Where is the spring relative to the settlement? Ideally, the community to be served should be downstream in order to reticulate by gravity.

In addition, the site around the spring as well as in the immediate vicinity of the spring should be inspected for sources of contamination such as pit latrines, cattle pens, and so forth. A water sample should be collected and tested to see whether the water is safe to drink. This will lay the foundation for strategies and methods to protect the spring against contamination.

#### *Information on potential environmental impact*

Check the vegetation and biodiversity to assess the potential impact of changes to be introduced by developing the water supply. Existing land use types upstream of the spring as well as in the vicinity of the spring should also be noted as these may have an impact on the quality and quantity of the water.

During the inspection, one should also find out if this is the only outlet of the water. If there are others, they should also be inspected with a view to assess their potential impact on each other and whether it will be practical to link them. How accessible are the springs is another question to be addressed.

#### *Technical feasibility of constructing the spring protection*

This visit should also provide answers regarding the technical feasibility of constructing the water supply and, if feasible, the type of construction to be installed. In relatively flat terrain, and where people live high above the spring line, other supply options such as protected dug well or boreholes should be considered. In the flat terrain, they are difficult to construct as the water often finds alternative outlets, difficult to protect against contamination, and are often subject to vandalism following failure. In the second case, the springs are understandably seldom used except in severe drought.

The technical feasibility inspection should include the determination of information on the origin of groundwater; the nature of water bearing strata; the topography and vegetation of the surrounding area; and the presence of possible entry points for contamination such as open fractures and fissures, sinkholes, gravel beds, etc. Some of the questions requiring answers will include:

- is the slope adequate for gravity supply and for drainage;
- will the gradient be adequate for storage downstream and give sufficient head at the standpipes and/or other taps;
- what protection from flooding and from erosion will be necessary; and,
- what is the suitability of the site for construction and the availability of local materials such as gravel, rock, etc for construction.

### *Protection of downstream uses*

Finally, it is important that some water should be allowed to continue to flow to maintain the biodiversity in the natural stream that the spring feeds. Thus it is necessary to ensure that there are suitable places for overflow pipes to lead this water back to the stream in a manner that does not threaten the spring protection and ancillary works. The rights of downstream users should also be remembered where such springs contribute significantly to stream flow. There are constitutional and legal requirements regarding the reserve water and they must be complied with.

## **10. DEVELOPMENT OF SPRING SOURCE FOR USE IN WATER SUPPLIES**

### **10.1 General**

The primary aim of spring development and protection is to prevent contamination of the spring thereby assuring the beneficiaries of a clean and healthy water supply. Ordinarily, animals using the spring for drinking and washing, and people drawing water using unclean pots and buckets tend to pollute springs and place all users' health at risk.<sup>10</sup>

Sometimes spring protection is carried out for social or quality of life reasons such as to improve access to the water by moving it closer to the people where possible and/or to increase the flow of the spring, thereby reducing water collection time for rural families. Other reasons for protecting springs include improvement of reliability by eliminating or reducing seasonal water scarcity; and improvement of usability of the spring by enhancing the aesthetic appeal of its surroundings and by allowing the water to flow in a more controlled manner.

There are several ways of developing and/or protecting a spring source to achieve these objectives. The choice of methods and of specific structures to build will depend on the type of spring concerned, its micro-topographic location, the yield, and the location of the households to be served relative to the geographical position of the spring. The foundation conditions, locally available materials, availability and cost of hand-held excavation and construction equipment, and the sophistication of the available labour can each also influence the choice of structures from an engineering and cost point of view.

Spring protection structures may be simple or modestly sophisticated depending on the site conditions as suggested above. For example, constructing a retaining wall with a gravel filter and simple outlet pipe may adequately develop a low yielding site serving a small community where households have easy access to the site. The next level could be a simple spring box with a simple outlet pipe. On the other hand, spring flow can be collected through a sophisticated system consisting of a lined tunnel and storage chamber - rather like the ancient Ghanats of Iran, except much shorter and without the vertical shafts. The most common spring protection structures are:

- simple retaining wall,
- collector drains,
- v-box, and
- storage chamber or spring box.

It is quite common to see these types built in varying combinations or as discreet structures in response to the specific conditions at each individual site and depending on the skills of the contractor. The process of protecting springs by constructing these structures is known as spring capping or tapping.

The CSIR has produced a useful booklet called "Guidelines for the protection of a natural spring". This booklet provides a step-by step method for the development of a spring eye and the construction of a V-box and water collection system.

It is reiterated that the development of gravity springs in low relief, gentle slope areas is not recommended. Such springs have small yields and are difficult to protect sanitarily. Rainwater washes the ground surface upstream of the spring, bringing with it mud, decaying matter and other dirt including human and animal faeces which can enter the spring water in spite of surface water drains, which may be too shallow due to inadequate land slope.

## **10.2 Preparation of the site**

Once a spring has been selected for development, the preparation of the site will be generally the same regardless of the structure to be built. The first step is to remove vegetation and debris from around the eye of the spring. Secondly, loose soil should be stripped away. This will make it possible to see the nature of the spring more clearly, whether it is a single 'eye' or there is a need to connect several eyes, and whether there is a natural problem of silt.

At this point in the process, it will be possible to review the proposed structure as to whether it is appropriate, and change it if not. Details of the construction method can also be worked out. In most cases it will be beneficial to excavate headwards into the spring. Excavation encourages more flow, less silt, and exposes better foundation conditions. In all gravity flow springs, excavation and soil stripping should extend at least 50 centimetres below the natural base of flow of the spring. This will help to minimise the risk of the spring seeking an alternative outlet after construction of the protection works.

The next step is to construct a cut-off trench or drainage ditch above the spring site to divert any surface runoff. This will become permanent protection against pollution of the collected spring water. The trench will prevent contaminated surface water from forming ponds and entering the aquifer through seepage or fissures. It is also necessary to create temporary diversion of spring flow in order to keep the working area dry during construction. Care must be taken to ensure that the spring(s) remain open and free from obstruction. The site is now ready for construction of the chosen spring protection.

## **10.3 Retaining wall structure**

Spring protection can be carried out by building a wall across the spring outlet in areas where gravity springs occur close to the community in such a way that every household has easy access to the spring. The flow has to be sufficient to meet the peak demand of the community without need for storage. A retaining wall structure of this type is the simplest spring protection structure that can be put up to provide sanitary protection to a spring and/or improve flow. The basic principle is to create a small dam behind the wall at a spring outlet and channel the water through a pipe built into the wall.



The retaining wall is built of rock and cement mortar. It must be of sufficient thickness and strength to withstand the pressure of the water. The height of the wall should be above the level of the wet season water-table to prevent erosion and undermining. The wall can also be built of reinforced concrete. The foundation of the wall must be built in the stable formation below the aquifer. A discharge pipe is built into the wall such that it extends sufficiently away from the wall to form a convenient spout for water collection.

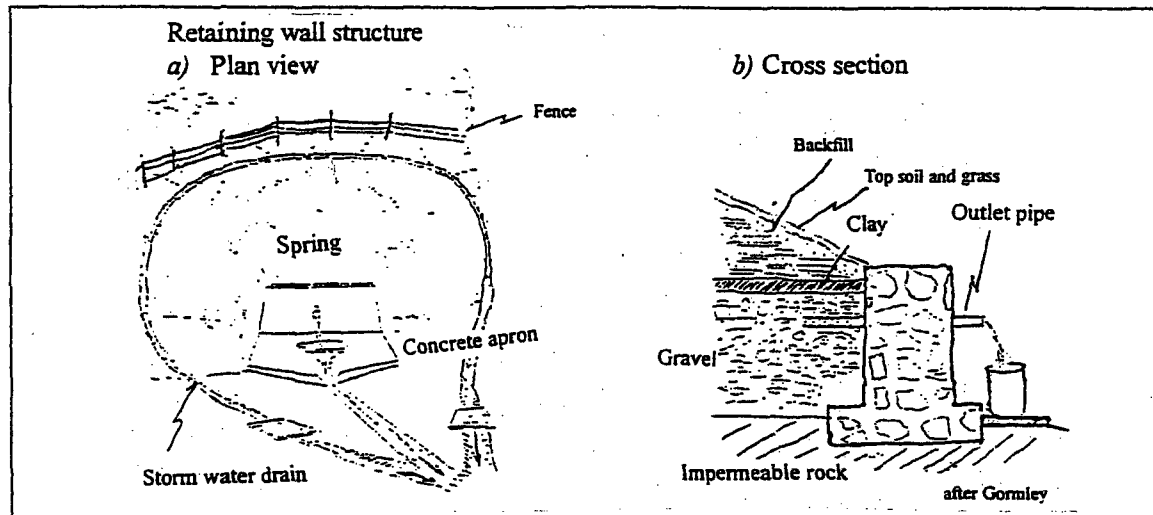

The diameter of the pipe will depend on the flow of water from the spring. If a tap is preferred on the discharge side, an additional pipe should be built into the wall as an overflow. The end of the pipe on the spring side should be perforated and covered by a filter pack consisting of gravel and sand. As an additional option, the perforated end may be wrapped in a porous geo-fabric. However, the pipe should be kept short so as not to create a stagnant zone. The space above the filter is then backfilled and sealed against surface contamination by a clay layer or strong plastic sheet. A concrete or rock apron should also be constructed below the discharge/overflow pipe(s) to protect the wall's foundation and to provide drainage away from the water collection point.

#### 10.4 Spring tapping by drains

Springs which seep over a large area can be tapped by construction of collector drains. Collector drains can also be used to link up spring eyes that occur close together in order to provide more convenient and efficient water collection through a single outlet. The drain collection system is sometimes also used to enhance flow at a collection point, although there are hydrogeological limitations to flow enhancement.

The specific design and dimensions of the drain system depend on the type of the spring and the nature of the aquifer. However, the basic structure consists of the drains, a cut-off wall, and a sump/spring box. After general preparation of the site, one metre wide trenches of appropriate length are dug to the left and the right of the spring outlet point. The trenches should extend in depth to at least 10 centimetres into the impervious layer below the aquifer. Appropriately sized perforated piping covered with a geo-membrane is then laid and covered by pebbles, gravel and sand. This will provide adequate filtration of the spring water. The pipes should be laid with a sufficient gradient to minimise clogging by sedimentation in spite of the filtration. The site is then backfilled. The top of the gravel pack should be at least 3 metres below the ground surface for sanitary protection if possible, otherwise it should be sealed with clay or plastic sheeting.

After this, the cut-off wall is built of rock and cement mortar, or concrete. The foundation of the wall must be built in the impervious formation below the aquifer. The height of the wall should be above the level of the wet season water-table to prevent erosion. There must be a good seal between the wall and the ground to prevent water seepage. Water must be directed into the drains. A collection chamber/sump or spring box is built at the centre of the winged wall. The water level in the spring box should never rise above the inlet level otherwise this can cause chronic blockage of the drains at best, or can result in loss of the whole system. Blocked drains can be difficult to wash out in a rural context because due to unavailability of the means to pressurise flushing water. Thus, the overflow should be at the same level as the inlet or just below it.

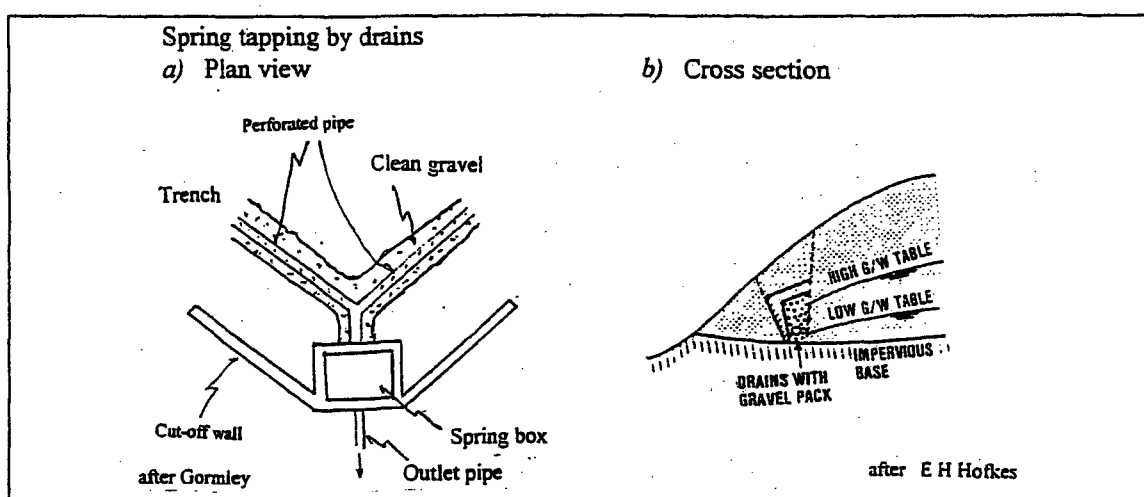

The drain system and spring box/collection chamber should be constructed in such a manner that contamination of the collected water is prevented. The overflow pipe and any drain pipes constructed for cleaning-out the system should have screened openings. The spring box should be fitted with a cover to allow access for future cleaning and maintenance. The ground above the drains should be sealed with a clay layer or plastic sheeting at the level of the top of the cut-off wall.

## 10.5 Spring boxes

A spring box or storage chamber can serve various purposes. It can provide sanitary protection, provide storage capacity and protect the eye of the spring from blockage. When a spring has a limited capacity it takes a long time for containers to fill up. This can cause long waiting times or queues at the water collection points. As a result, some people may not bother to clean their containers to limit wastage of water, which may cause health risks.

A spring box will collect water during the times that the spring is not in use such as at night. It serves as storage when there is no other storage provision and helps to alleviate situations similar to that just described. Any excess water is allowed to flow out through the overflow pipe to continue along the natural drainage, maintaining the downstream ecosystems. The spring box can serve as a silt trap at the same time.

In case there are several springs in an area, each could be provided with a small spring box, and then all are connected to a common reservoir from which the water can be collected or led into reticulation. Each spring box should be provided with an inlet, an overflow outlet and a scour outlet. The overflow outlet and a scour outlet should be sufficiently protected by screening.

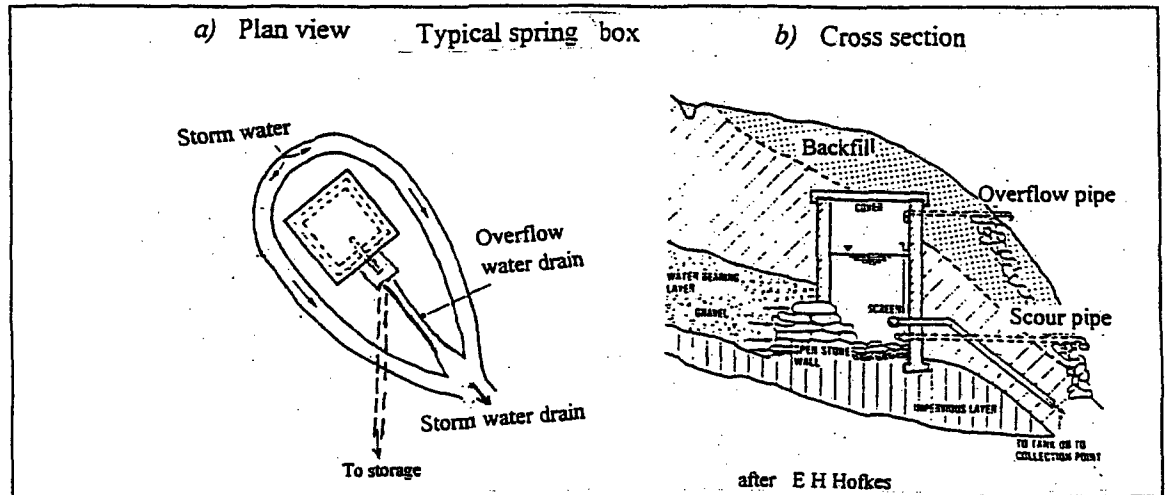

A spring box must be installed in such a way that its foundation is in the impervious rock below the eye. A seal with the ground is created to prevent water from seeping under the structure and undermining it. As a rule, the spring box should be sized to cover the spring completely so that it does not seek an alternative outlet. It is also important to position the overflow pipe in such a manner that there is little or no back pressure exerted against the spring inflow into the box.

There are various types of spring boxes depending on the type of spring, its flow, and geology of the site. A typical installation in granular material is briefly described below. After the general site preparation as described before, a box structure of the required dimensions is built at the spring. Part of the "back wall" is built as an un-mortared stonewall to facilitate inflow of the water. The foundation of the box should be at least 50 centimetres into the impervious rock below the aquifer, and the top of the box should be higher than the position of the high water table. The un-mortared part of the back wall should lie between this water-table and the impervious rock. This wall is also known as the inlet wall. Stone rap and a gravel filter are placed between the spring and the inlet wall. The area is backfilled and sealed against contamination from surface water seepage with tamped clay. An access manhole for future cleaning and maintenance is provided in the "roof" of the spring box and should be covered by a concrete slab with handles.

Some variations of the spring box are illustrated below. The vee-box illustrated below is a common special case constructed as a sump where flow is collected from a wide area into the spring box before being led off by gravity to the main storage downstream. The design incorporates a small collection-box-cum-silt-trap in the middle of the two wings of a V-shaped retaining wall. The shape of the box may be triangular (i.e. V-shaped) or rectangular. The name vee-box is from the shape of the whole arrangement.

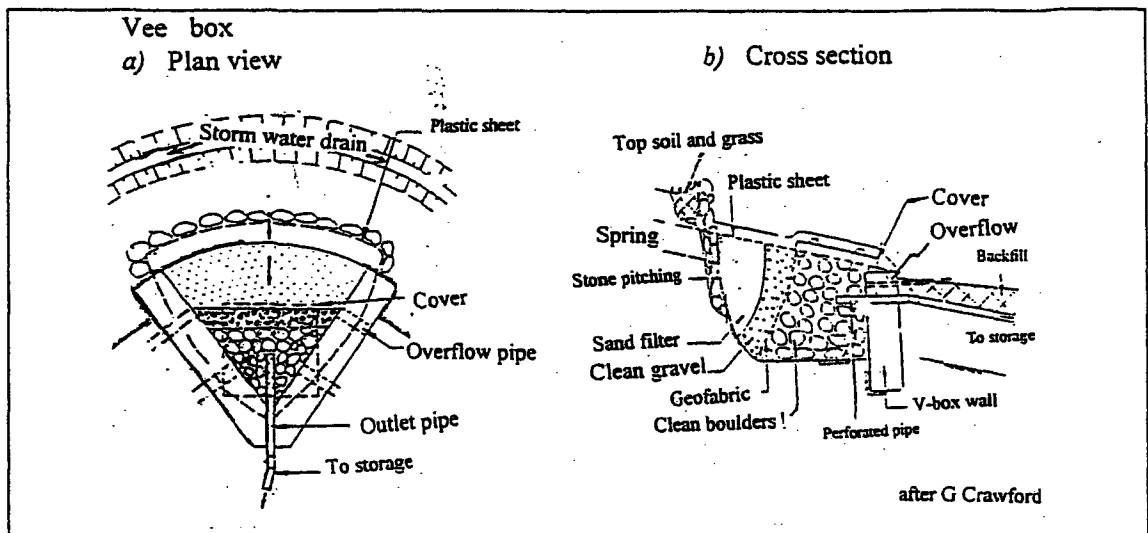

Two other special spring box types are illustrated below. An important point to note is that in cases where a spring enters the box from the back wall or from the side walls, the water level in the box should be kept lower than the spring outlet to prevent build up of pressure against natural flow. In the special case of artesian springs where the water enters the spring-box from below, fine material should be removed to improve the natural flow.

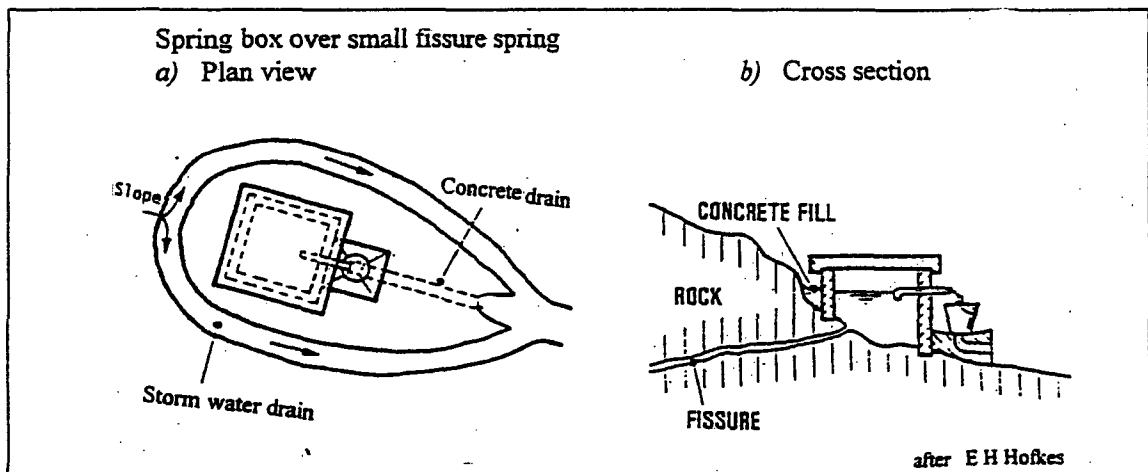

The flow from artesian springs is normally more localised than other springs. This makes construction of a spring-box easier. In the construction of a spring box at an artesian spring where flow is from below, there is normally no need for a sand filter. Stone rap, or even coarser material such as boulders, is usually placed over the eye of the spring to replace the loose soil and mud removed from the eye. Care should be taken to ensure that this improves rather than blocks the natural flow of the spring. A typical construction over such an artesian spring is illustrated below. The box should be sealed against downward seepage of less clean water from above.

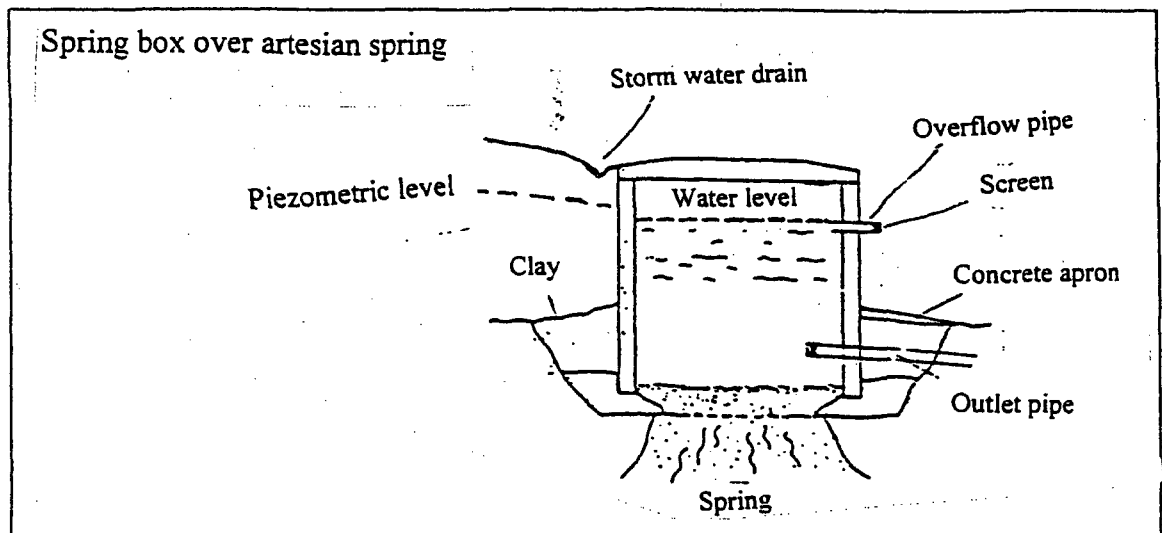

Drains should be provided upstream of the spring and around the spring box to prevent overflow water from forming ponds and percolating back into the spring box.

## 10.6 Spring tapping by tunnels

In fractured rock aquifers such as those in Drakensberg basalts, flow occurs in many discrete fractures a few of which may be interconnected. The flow may exit at several discrete seep springs of differing strength, at different levels, but within the same general area. Typically, the accumulation of debris at some of the outlets, or poorly designed attempts to tap them, lead to cessation of flow at that seep and increased flow at another. Effective collection of the water can be achieved by constructing short collector tunnels into the hillside similar to the ghanats of ancient Persia. The tunnel is designed to intersect several of the fracture zones and lead the water to one outlet. The walls of the tunnel may or may not need support depending on rock stability. Protection from contamination will be necessary. The area above the tunnel should be fenced off and, ideally, no dumping, construction of pit latrines, or other pits which will allow standing water to percolate should be allowed.

Tapping springs by tunnel is a fairly expensive exercise. It is therefore unlikely to be justifiable where substantial increase in flow is not likely to be achieved. Furthermore, it will only be cost effective where the beneficiary community is large, or where the water will be used for other purposes in addition to primary domestic consumption.

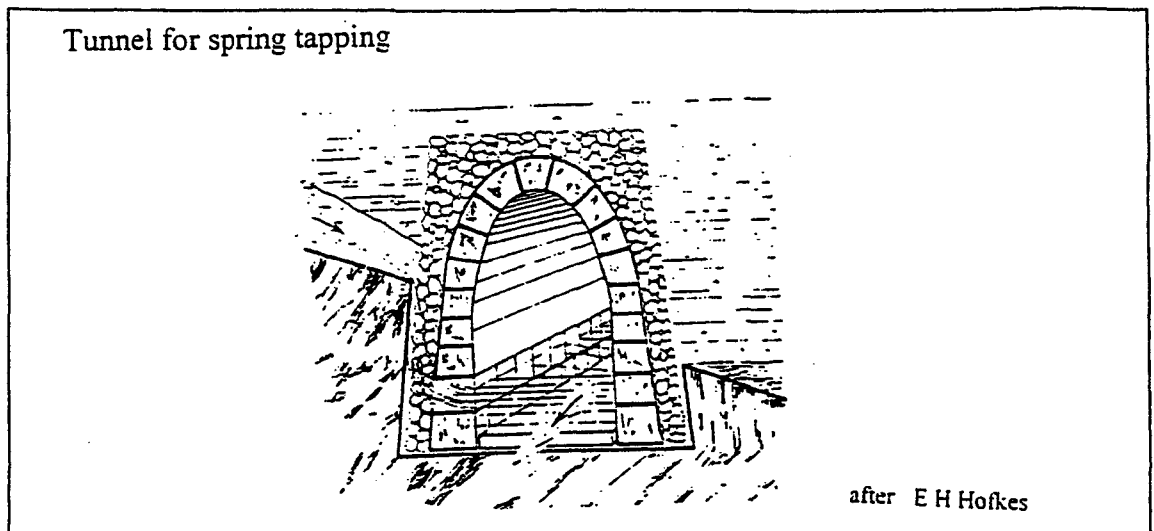

## 10.6 Sanitary protection of springs

The area of the spring site should be fenced off, at least 50m upstream and 10m around the site. This will prevent animals and humans defecating in the area. A drainage ditch is required above the spring site to divert any surface runoff thereby reducing risk of pollution at the spring box. Water running off from the overflow pipe should be channelled off until past the fence in areas where animals used to drink from the spring. This will provide the animals with access to water without compromising the health benefit to the community.

Pit latrines, wastewater and sewerage soakaways, and cattle pens pose a high risk of faecal contamination of springs. Thus, they should be placed sufficiently far from springs and downstream of them wherever possible. This is particularly important where the water-table is shallow or where open fractures and fissures are common. Actual safe distances depend on site factors such as soil type, geological features, topography, and so on. As a rule of thumb, they should all be placed at least 60 metres on gentle slopes and not less than 100 metres on steeper slopes.

Risk of toxic contamination also occurs where chemicals, pesticides, fuels and oils, etc. are dumped on the land near a spring or where the water-table is shallow. Some chemical fertilisers and other agricultural chemicals can also contaminate water and should be used with care and as advised by agriculturists.

## **11. UTILISATION AND MAINTENANCE OF SPRING-BASED GROUND WATER SUPPLY SYSTEM**

A water supply system should be considered by every community as one of its most valued resources, and should therefore be carefully monitored and looked after. Like a properly maintained vehicle, a water supply that is well looked after lasts a long time and is reliable.

On the other hand, a neglected system breaks down frequently, leaving people without drinking water and ultimately wears out in much less than the design life. As an example, most problems can be avoided by ensuring that children, vandals and livestock do not damage or interfere in other ways with the spring protection, the storage, pipes, and valves and taps. Besides just keeping the area clean and protected, the additional steps outlined in the following paragraphs should be taken to protect this valuable asset.

A well-looked after water supply system is likely to last longer. The water committee should appoint a person who can be trained to monitor and repair all the elements of the system as and when necessary. The elements consist of; the spring box, overflow pipes, pipeline including joints and bends if any, valves and taps, and the storage tanks. Unlike a system based on boreholes, wells, or surface water, looking after a spring-based system does not involve much work, nor is it a full time job. Besides, most of the "work" consists of monitoring rather than repairs. Some of the monitoring activities that are necessary are discussed in the following paragraphs.

Taps and valves should be checked frequently for leaks and other signs of damage or wear. The whole community can help with this by reporting any signs they see. Public standpipes undergo heavy daily usage. Thus, washers can wear out fast. Replacing these washers as soon as possible is best.

Checking for leaks along pipelines, especially at joints is another important monitoring activity. Prompt repair of leaks can prevent more serious problems such as erosion and subsequent rupture of the pipelines. Any erosion or undermining should be promptly repaired by backfilling and taking any steps that help to prevent recurrence. Where cracks or other similar damages that can facilitate entrance of contaminants into the water have already occurred, appropriate repairs are also necessary.

Similar checks for leakage and checks for damage caused by vandals should be carried out at the storage tanks and at the spring box. Checking the overflow pipes for blockages is also necessary, as is ensuring that the overflow pipes and the areas around them are still in a safe and sanitary condition. Depending on the type of structure constructed, spring boxes and storage tanks should be checked for silt and other sediments, and cleaned-out through the scour facilities provided.

Any blockages of the storm water diversion and drainage ditches must be cleared. In addition, ensuring that such drains and ditches are still in a safe and sanitary condition is important. Any erosion should be repaired promptly before pollution problems result.

The area around the spring, around the storage, and around the standpipes must be kept clean and sanitary. Puddles of standing water should not be allowed to form at or near these places. The people should be encouraged to develop a culture of keeping these surrounds clean and puddle-free through a health and hygiene education programme where necessary.

The flow from the spring should be measured on a regular basis (say monthly) and recorded. These records give valuable information that helps to anticipate and plan for water shortage problems such as drought, groundwater over pumping upstream of the spring, and other factors such as negative land use changes within the catchment of the spring. Flow measurement is best carried out at the spring-box overflow pipe. The checking of overflow pipes mentioned previously may be carried out at the same time.

Water samples for quality analysis must be taken at intervals ranging from a few weeks to several months or years depending on sanitary conditions and/or land use types in the area adjacent to the spring. Quality analysis helps to detect contamination of groundwater early so that preventive or corrective action can be taken early enough, before people start getting sick from contaminated water. Also detecting contamination early is very important because once groundwater is polluted, it takes many years to remedy it - sometimes it can never be restored.

Finally, growth of woody plants whose roots can penetrate and ruin the spring-box or associated filters should be discouraged. Spring rehabilitation or reinstallation is a major and rather costly exercise. With conscientious appropriate care and maintenance as outlined above, it should not become necessary for many years.



## 12. REFERENCES

- 1 - Bill of Rights, Constitution of South Africa.
- 2 Department of Water Affairs & Forestry (1997) White Paper on Water Policy : South Africa Government Publications. Pretoria.
- 3 Lenehan, A. (1996) The Spring-box Solution - choosing the right water-supply technology for Southern KwaZulu Natal. Waterlines, Vol. 15 No.2, October 1996.
- 4 Hofkes, E.H. (editor) (1983) Small Community Water Supplies. John Wiley & Sons. Chichester.
- 5 King, G. (1997) DWAf Spring Survey : KwaZulu Natal South Coast. Unpublished survey data collection forms. Department of Water Affairs & Forestry. Durban.
- 6 Steel, E.W. and McGhee, T.J. (1979) Water Supply and Sewerage (5th Edition) McGraw-Hill. New York.
- 7 Klimentov, P.P. (1983) General Hydrogeology. MIR Publishers. Moscow.
- 8 Gormley, W. Goff, D. and Johnson, C. (1984) A Workshop Design for Spring Capping. US AID. Washington.
- 9 Jayakaran, S.C. (1988) Rural Water Supply: Sierra Leonean Example - A Case Study. Developing World Water. Grosvenor Press International. London.

**A GUIDE TO:**

**SMALL SCALE DESALINATION**

**PREPARED BY**

**DIVISION OF WATER, ENVIRONMENT AND FORESTRY  
TECHNOLOGY, CSIR**

## TABLE OF CONTENTS

INTRODUCTION .....	1
Aim of this guideline manual .....	1
1.    THE NEED FOR SMALL SCALE DESALINATION.....	2
2.    METHODS OF SMALL SCALE DESALINATION.....	3
2.1    Ion exchange.....	3
2.2    Electrodialysis.....	4
2.3    Reverse Osmosis.....	6
2.4    Distillation .....	8
2.5    Chemical precipitation .....	11
2.5.1    Hard waters.....	11
2.5.2    Heavy metals.....	12
2.5.3    High levels of fluoride.....	12
2.5.4    Phosphates .....	12
2.5.5    Nitrates.....	12
3.    FACTORS GOVERNING THE CHOICE OF DESALINATION SYSTEM.....	13
Alternative sources .....	13
Proportion of water to be treated.....	13
Volume of water required.....	13
Institutional and operating skills.....	13
Financial considerations .....	14
Water quality .....	14
References .....	14
Appendix - Desalination cost summary sheet .....	15

## INTRODUCTION

Desalination is a process whereby water is treated to reduce the level of dissolved solids. This becomes necessary when the water is unacceptable for human consumption due to its high level of saltiness, or when a particular dissolved element is at a level which is a health hazard. Typically in South Africa such problems occur in borehole waters in certain regions where the salinity (saltiness) is very high, or where high levels of either fluoride or nitrates are found. In such cases it may happen that the borehole is the only available source of water for the community, and the prospect of finding alternative sources of water at an affordable cost is very low. Therefore the community must either live with this particular source of water, or must move to another area.

In many cases communities have lived for generations in an area which has saline water sources or boreholes with a high level of fluoride or nitrates. These communities have grown accustomed to the saline water, or have a mix of water sources with a purer source for drinking (e.g. rain water). However with the increases in population and with the desire to improve the water supply to these areas, desalination may need to be considered as an alternative to ensure an adequate quantity of safe drinking water to every household.

Water sources with high levels of nitrates and fluoride is of particular concern with small children under 5 years of age. Nitrate levels greater than 20mg/ℓ may result in chronic tiredness, or even in a blood disorder in babies under 1 year. Fluoride levels greater than 1.5 mg/ℓ may result in discolouration of teeth and a hardening of bones making them brittle. Where the water sources of a community have excessive amounts of fluorides or nitrates, steps should be taken to at least provide the children with desalinated water for drinking purposes.

This guideline manual describes the range of desalination options which can be considered for various problematic water sources, and sets out a process for developing a desalination treatment system for a rural community or a household in a remote area.

### **Aim of this guideline manual**

The primary aim of this manual is to give guidance on what measures can be taken to deal with drinking water sources which have a level of dissolved salts which renders the water less fit for human consumption. In particular the implications of the capital and operational requirements of any desalination technique must be carefully considered before selecting a particular desalination technology. This manual gives guidance on the minimum factors which should be considered when desalination is required.

The different desalination options which can be employed for rural water supplies are described, and methods for selecting the most appropriate method are set out.

## 1. THE NEED FOR SMALL SCALE DESALINATION

Rural communities and farmers in many arid and semi-arid regions rely on ground water sources for their main water supply needs. In many instances these sources are saline or contain unacceptably high concentrations of fluoride or nitrates. In severe cases the borehole is the only water source and may be unfit for human and animal consumption. In South Africa such situations are not confined only to the semi-arid regions along the west coast, but also occur in the higher rainfall areas along the eastern and central parts of the country.

Groundwater becomes saline when the geology consists of old cretaceous deposits which were once part of the sea bed (millions of years previously in geological history), or contain higher levels of specific salts. In certain instances man's activities have resulted in contamination of the groundwater with additional salts. This is particularly the case with high levels of inorganic fertilizers being used on agricultural lands (resulting in higher nitrate levels in the groundwater), seepage of on-site sanitation leachates into the groundwater table (increased nitrate levels), or large scale mining activities (increased sodium and calcium sulphate levels).

Communities reliant on these water supplies may experience certain health effects from high levels of these salts, particularly fluoride and nitrate. The following table indicates acceptable and problem levels of salts with typical sources of water in South Africa:

Salt	Safe levels	Safe but may affect sensitive groups	Unsafe levels	Affect of high levels
Fluoride (F <sup>-</sup> )	< 1.0 mg/l	1.0-1.5 mg/l	> 1.5 mg/l	Mottled teeth, bone hardening
Nitrate (NO <sub>3</sub> <sup>-</sup> )	< 10 mg/l	10-20 mg/l	> 20 mg/l	Tiredness and blood disorder
Sulphate (SO <sub>4</sub> <sup>-</sup> )	< 400 mg/l	400-600 mg/l	> 600 mg/l	Taste and diarrhoea
Total dissolved salts (TDS)	< 1000 mg/l	1000-2400 mg/l	> 2400 mg/l	Taste and adverse effects on heart and renal patients
Arsenic (As)	< 0.05 mg/l	0.05-0.2 mg/l	> 0.2 mg/l	Poisoning of nervous system
Chloride (Cl <sup>-</sup> )	< 200 mg/l	200-600 mg/l	> 600 mg/l	Taste and nausea
Hardness (as CaCO <sub>3</sub> )	< 200 mg/l	200-300 mg/l	> 300 mg/l	Scaling of kettles and poor lathering of soap

**Table 1: recommended limits of specific salts in domestic water supplies**

Rainwater harvesting and storage is a means of obtaining an improved quality of water for domestic use, but this source is normally insufficient for the long dry periods when little or no rain falls. In particular recurring droughts in Africa and other world regions have placed an emphasis on the need for low cost yet reliable small scale desalination equipment to produce potable water from the saline water sources.

## 2. METHODS OF SMALL SCALE DESALINATION

There are several methods of desalination by which small quantities of water can be purified. The most appropriate methods will generally fall into one of the following categories:

Process	TDS range (mg/ℓ)	Typical Application
Ion exchange	500 - 1 000	specific ion removal e.g. fluoride (F <sup>-</sup> ) and nitrate (NO <sub>3</sub> <sup>-</sup> )
Electrodialysis	500 - 5 000	Partial reduction in salinity and/or removal of divalent ions, where electrical energy is readily available.
Reverse osmosis	500 - 35 000	Desalination of medium to larger volumes of water where electrical or mechanical energy for pumping is readily available.
Distillation	no limit	Small scale desalination (household level) and/or desalination where very high TDS levels are encountered.
Chemical precipitation	no limit	Removal of metal salts through changes in pH and/or alkalinity.

### 2.1 Ion exchange

Ion exchange is a process whereby the water is passed through a filter system which is filled not with sand but with a special resin or combination of resins. As the water flows through the resin beds, certain problem ions (e.g. fluoride, nitrate, calcium, sodium, or chloride) are attached to the resin beads and alternative safe ions are released from the resin back into the water (e.g. hydrogen, sodium, hydroxide). The specific ions exchanged are dependent on the nature of the resin beads, and on the method used to regenerate the resin after it is saturated with ions removed from the water.

The following diagram (figure 1) shows the method of ion exchange applied to water with a high concentration of a particular salt.

Taking calcium as an example, when the ion exchange unit is operating in "service", the calcium ions in the water are attached to the resin, and are exchanged with sodium ions that are released from the resin. The calcium is thereby removed from the water. At some stage the resin can no longer absorb any more calcium, and it is then saturated. The resin can be reused if it is "regenerated". In this process the calcium ions are removed from the resin and again replaced with sodium ions. This is done by washing the resin with a very strong sodium chloride (salt) solution. After the resin has been regenerated, it can be again used in service mode to remove calcium from the source water.

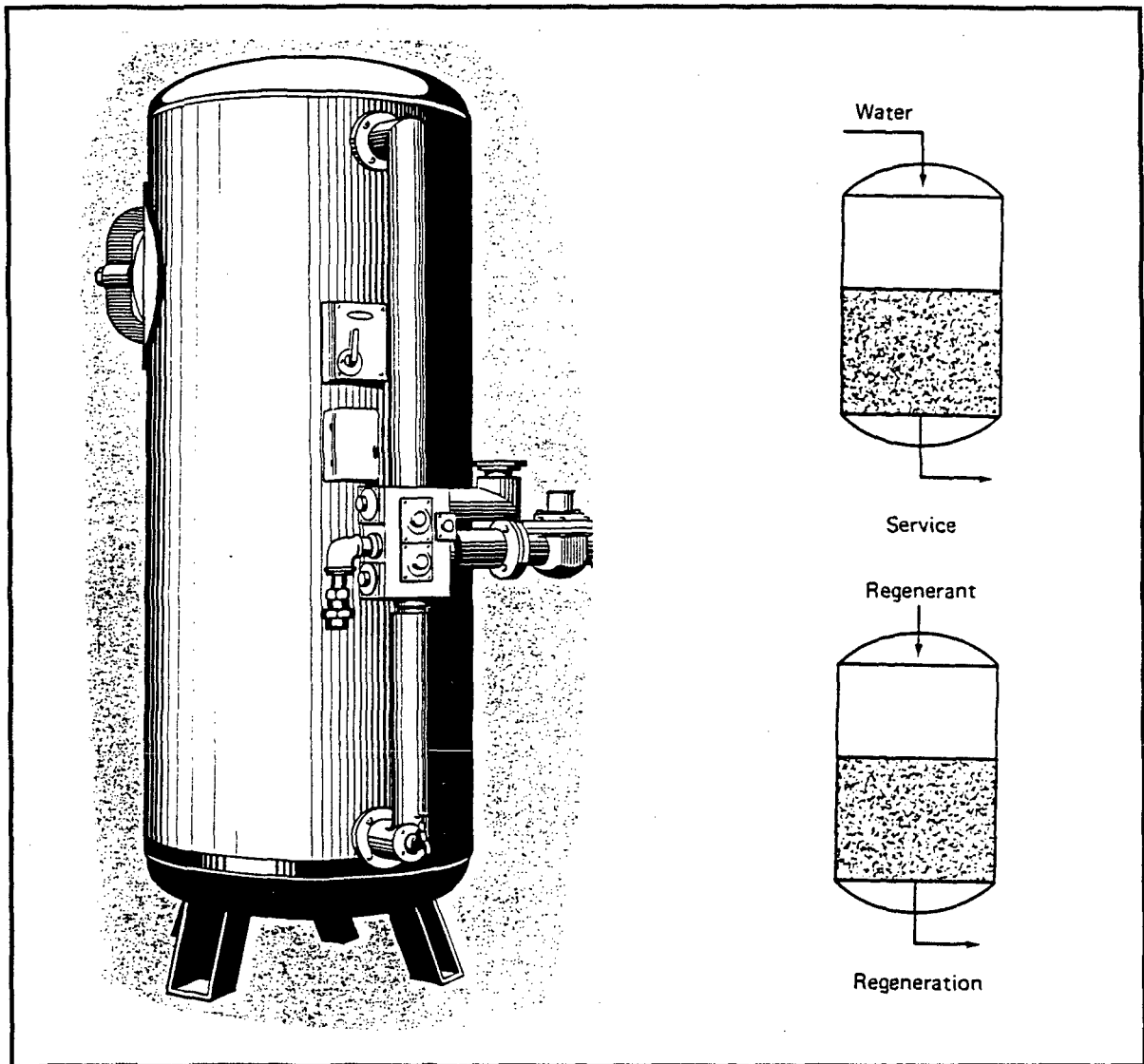

**Figure 1: Ion exchange process for the removal of salt from water**

Note that special arrangements must be made for the disposal of the regeneration water, which will have a high concentration of the salt removed from the source water. This may be placed in evaporation ponds or other safe disposal sites.

For certain applications (e.g. removal of fluoride from water) strong acids or bases are required for regeneration of the resin. Special safety precautions must be applied when storing and handling such chemicals.

## 2.2 Electrodialysis

Electrodialysis is a process whereby electrical charge is applied across special membranes each of which only permit either positively or negatively charged ions to pass through. By "stacking" these ion-selective membranes in a particular array, water flowing between alternative membranes becomes desalinated, while the water flowing between the other membranes becomes more saline (i.e. forms a brine). The desalinated

water is then available for use, while the concentrated brine must be discarded. This process is illustrated in the following diagram:

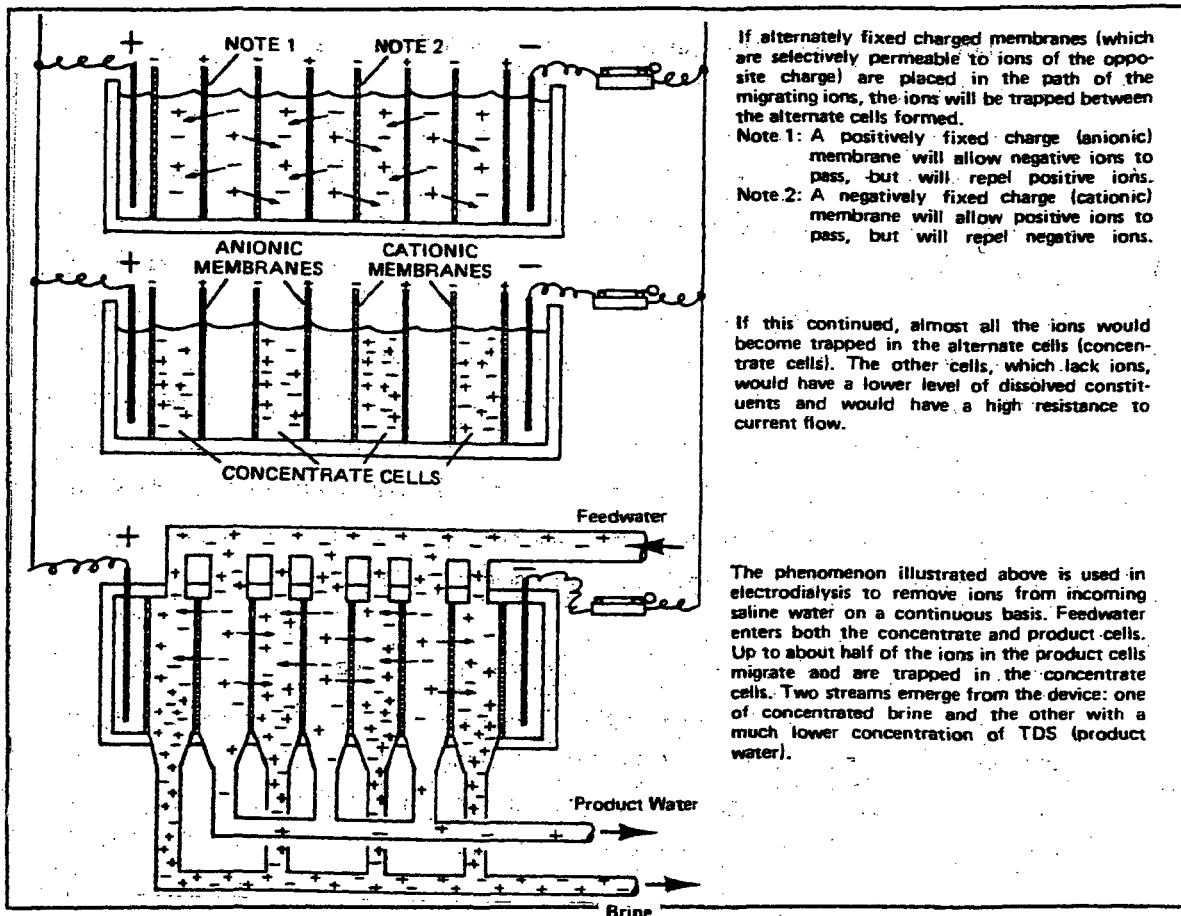

**Figure 2: Electrodiolysis process for the removal of salt from water**

Electrodiolysis (ED) is used extensively throughout the world for desalinating brackish waters. However this technology has not been used to any significant degree in rural areas due to the complexities of its operation. However, with the latest developments in the technology, ED systems can now be considered for use in rural areas. Advantages of ED are that the membranes used are relatively robust, and ED does not require chemicals except now and again for cleaning the membranes.

As with ion exchange, special arrangements must be made for the disposal of the concentrated waste salt solution, which will have a high concentration of the salt removed from the source water. This may be placed in evaporation ponds or other safe disposal sites. By recirculating the brine, the volume of the concentrate can be reduced to relatively small quantities.

Electrodiolysis can even be adapted to operate using a solar energy power source. For example, in an application in India, a 450 peak watts photovoltaic panel was used to power an ED desalination system to produce 1000 l/d of good quality water (TDS  $\leq$  1000 mg/l) using only solar energy as the power source.

ED is competitive with reverse osmosis for normal brackish water desalination applications (TDS  $<$  5000 mg/l), and hence it could be considered for use in rural areas. However further research and development is required to adapt these systems to small rural water treatment applications, especially with respect to



simplifying the operational requirements. Electrodialysis and reverse osmosis are likely to be the technologies of choice for producing larger quantities (>500 l/d) of desalted water in rural areas.

Electrodialysis has an added advantage of being able to treat moderately scaling waters (i.e. high in calcium and/or magnesium salts) without loss of productivity as a result of the clogging of the membranes. However in this case a significantly higher level of operational attention may be required.

The following diagram (figure 3) shows the method of desalination by electrodialysis applied to a brackish source water.

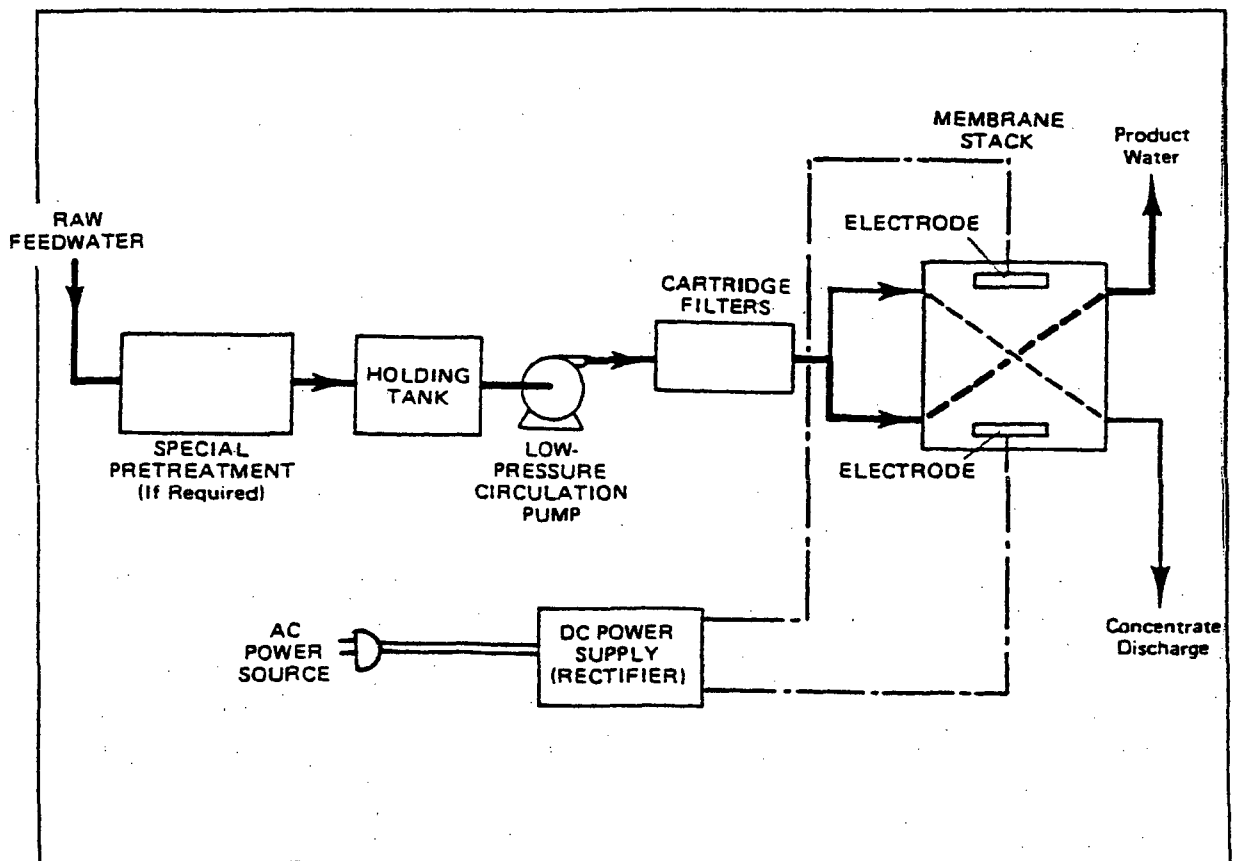

Figure 3: Electrodialysis process for the desalination of a brackish water

### 2.3 Reverse Osmosis

Reverse osmosis is a technique adopted from the natural osmosis process used by plants to absorb water from the soil and to transport it to all parts of the plant. In the case of plants, a semi-permeable membrane in the roots allows water molecules to pass into the roots, but prevents the movement of salts. The membrane acts as a very fine filter which prevents the passage of salt. By applying pressure in excess of the osmotic pressure to a salt water solution which is in contact with a semi-permeable membrane, water molecules from the salt water solution can be forced through the membrane and hence desalinated. This is the reverse direction of normal osmosis, and hence the process is called "reverse osmosis". Large artificially manufactured semi-permeable membranes have been developed for the commercialisation of this process, and many thousands of litres of fresh water are produced daily by this method.

Technological advances have resulted in the use of reverse osmosis (RO) systems for fresh water production to increase rapidly in the last two decades. RO is particularly suited to the desalination of brackish water and has already been used successfully in rural applications in South Africa.

The heart of any RO system is the membrane. Selection of the best membrane for use in a particular situation is very important, but in a rural situation selection of the hardware (pumps, control valves, flow measurement, piping, cleaning system) is of equal (if not more) importance. Experience in South Africa have indicated the following specific requirements for a reverse osmosis system which will be used in a rural location:

- \* whilst previously automated systems were considered inappropriate for rural areas, newer experience has proven the merits of more automated systems, especially for remote locations;
- \* pretreatment should be kept to a minimum, but with well controlled (automated if possible) addition of chemicals in preference to hand dosing;
- \* if available, membranes which are compact and robust should be used (there are a number now available which meet this requirement, although mostly manufactured outside of the country);
- \* automatic controls can be very effectively incorporated into a system, thereby improving performance, reliability and protecting the costly membranes;
- \* large storage facilities should be provided for the water prior to desalination to allow for pretreatment and quality corrections;
- \* on the job training should be given to the operators, with a long supervisory period by the contractors;
- \* if possible, pump types which are familiar to the operators should be used;
- \* physical cleaning should be incorporated as a regular operation (e.g. sponge balls in tubular systems, daily water flush) and chemical cleaning less frequently or only when needed; and
- recovery should be kept low (< 60 %) to minimize the deterioration of the flux and salt passage through the membranes.

The reverse osmosis process is similar to electro dialysis, except that water pressure is used to separate the salt from the water rather than electricity. The source or feed water is pumped at a high pressure into the membrane module. A portion of the water flows through the membranes, leaving the salts behind. These salts are carried away by the source water which flows rapidly across the membrane surface. In this way the source water becomes more and more saline and requires a higher and higher pressure to force water through the membrane. The output from the membrane is a clear desalinated stream and a second concentrated brine solution. This concentrated solution must be disposed of as with ion exchange or electro dialysis.

RO is able to produce fresh water from saline water with a relatively low energy input, and hence its use for rural areas is very promising. It has not found extensive usage to date because of its complexity and cost. However, RO does offer significant benefit of scale, for example in South Africa a commercially available unit which can produce 600 l/d of fresh water costs only twice as much as a unit producing 30 l/d. This indicates that RO should be superior to other systems when requiring larger quantities of water. Where electricity is available in a rural area, RO could prove to be an economic choice to produce fresh water where saline or specific salt conditions occur.

The diagram (figure 4) shows the method of desalination by reverse osmosis applied to a brackish water.

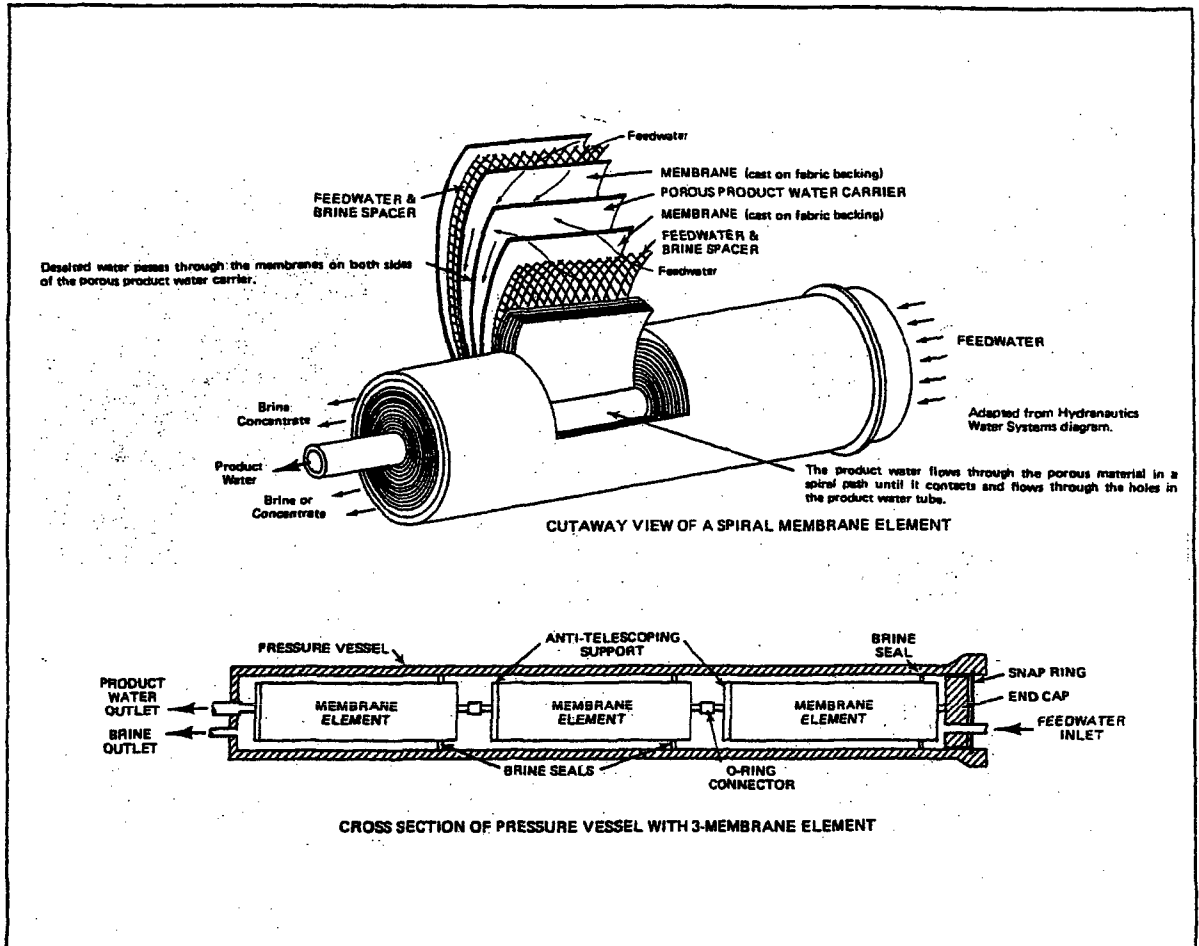

**Figure 4: reverse osmosis process for the desalination of brackish water**

## 2.4 Distillation

Desalination by distillation is the oldest and most well known method for the desalination of saline water. In this process the water is heated to produce water vapour (steam) which is free of salts. The steam is then condensed on a cool surface to form distillate (desalinated water).

A number of different distillation methods for the desalination of water are in use, but not all are suited for use in rural areas. Distillation systems generally require more energy than other desalination systems because of the need to evaporate the water. Various techniques have been developed to improve steam production at lower temperatures and to recover the heat from the condensation section to preheat the incoming water. Relatively efficient large scale plants are in use all over the world using these techniques.

However a very simple solar distillation process has been available for use in remote areas for many years. Solar distillation systems may not be as efficient as their large commercial counterparts, but are extremely simple and cheap to operate. Although these systems produce very small quantities of water per day (typically 5l per square metre of solar panel per day), their cost and simple function make them a technology of choice for rural households. If the water produced by the solar distillation units are only used for drinking and cooking, one or two square metres of panels are all that a family requires.

The age-old greenhouse type solar still has been tried and tested in many parts of the world. In particular the greenhouse type still has shown considerable potential for rural areas due to its simplicity. However, this still does suffer from problems of low efficiency and relatively high capital costs. Although operating costs are negligible, the cost per litre of fresh water obtained is relatively high due to the relatively high capital costs (from a low-income family point of view).

Many alternatives to the greenhouse type solar still have been attempted, but most of these are too complex or costly for use in rural areas. However, one innovation that does show promise is the cloth type still. Cloth or wick stills can be assembled in a multi-effect configuration which results in a much improved efficiency. There still exist certain restraints on their use in rural areas due to complexity and possible scaling problems.

Although there are many different designs of solar distillation units (solar stills), most operate on the same basic principles. Solar energy in the form of heat energy is employed to increase the temperature of the saline water. At the higher temperature more vaporization takes place. The vapour (which does not contain salt) is condensed on a cool surface and the water droplets formed are collected for use as desalinated water.

A simple "greenhouse" type basin solar still (figure 5) consists of a shallow basin of saline water covered with a transparent, sloping roof. The basin is painted black or lined with a black, impervious material.

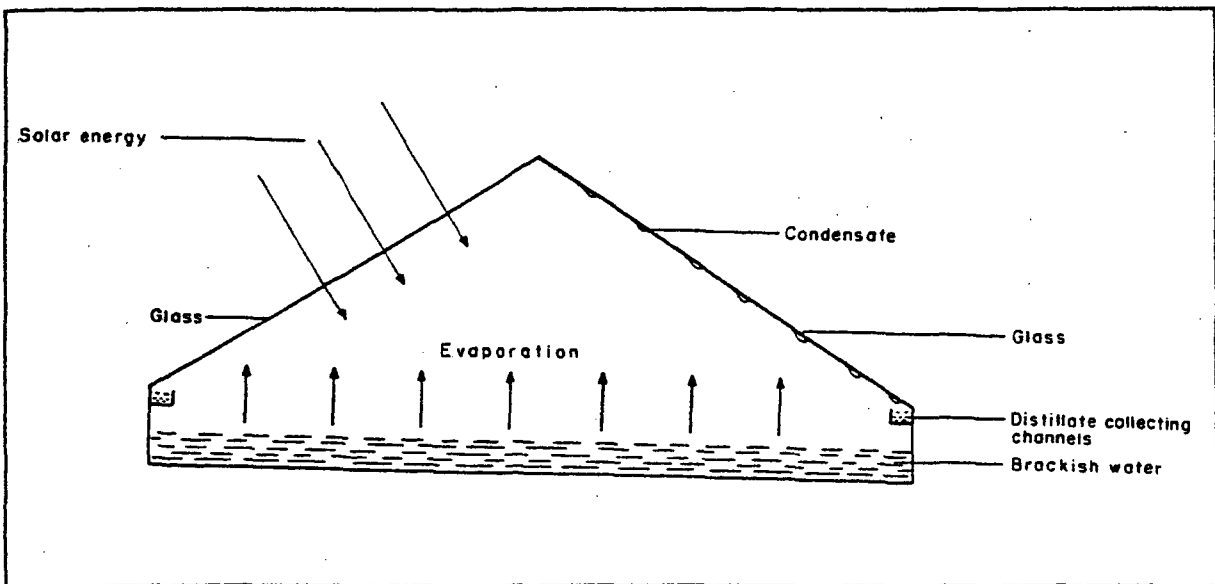

Figure 5: Greenhouse type solar still

Solar radiation passes through the cover and is absorbed on the black bottom, heating the water. Vapour is formed which convects upwards to contact the cooler covers, where it condenses. The pure water droplets thus formed on the underside of the cover flow down the sloping cover to be collected in troughs.

The most important factors affecting the performance of this type of still are:

- \* insolation (exposure to the sun) of the basin;
- \* ambient temperature;
- \* vapour tightness of the unit; and
- \* heat loss through the base (insulation).

In addition, production is affected by the depth of the brine in the basin of the still, with improved production associated with shallower depths. A practical minimum of 5 cm depth is recommended to

avoid the formation of dry spots. The optimum slope of the cover is in the range of  $10^\circ$  to  $20^\circ$  to the horizontal.

Water production ranges from 1 to 5 l/m<sup>2</sup>.day, depending on the climatic conditions and the other factors mentioned above.

Advantages of the greenhouse type of still are:

- \* simplicity of construction;
- \* ease of operation;
- \* ability to desalinate most waters without the need for pretreatment;
- \* all components can be obtained locally;
- \* can be constructed and maintained by less technically trained personnel;
- \* consistently produces a high quality product;
- \* no auxiliary power requirements.

Disadvantages of the greenhouse type of still are:

- \* large investment cost for large installations (there is little benefit of scale on total costs);
- \* low production per unit area;
- \* low efficiency (single effect system);
- \* basin subject to problematic scale formation;
- \* susceptible to damage by wind and hail;
- \* requires regular (but minimal) maintenance;
- \* it is a "new" technology to most rural people.

Performance of solar stills can be improved by using the surfaces of the glass covers of the stills for the collection of rainwater, and using preheated or waste hot water as the feed to the stills.

Methods of preheating include the use of solar ponds or solar collectors. If sufficient storage is allowed for, operation of the still could be extended over day and night. Solar ponds are able to achieve water temperatures of up to  $80^\circ\text{C}$  when an adequate salt gradient is maintained. This technology is simple in construction and, where land is available at low cost, an economically attractive method to upgrade the greenhouse type solar still. Solar collectors are either flat collectors or concentrating collectors, with some more suitable to rural applications than others. The use of small diameter, black, thin walled, polyethylene pipe in a suitable configuration is an example of a low cost solar collector which may be applicable in certain situations.

#### *Modifications to conventional solar stills*

Because of the poor efficiency and other shortcomings of the conventional greenhouse solar still, a number of modified stills have been designed, constructed and tested. Almost all of these modified stills are substantially more complex than the greenhouse still, and their use in rural areas must subsequently be critically assessed against the prevailing situation in the rural area according to certain criteria. Despite the increased complexity however, some of the modified stills have resulted in a substantial improvement to the conventional stills, and may well find beneficial application in selected rural areas.

In South Africa the simple wick still has been developed and successfully tested in rural areas. The saline water slowly flows through a black cloth (wick) on the sloping base of an enclosed glass faced container. As with the greenhouse still the water evaporates and condenses on the glass cover from where it is collected separately from the concentrated brine. The advantage of this is that the sun can more rapidly heat the thin water layers flowing through the cloth. The process is depicted in figure 6 below.

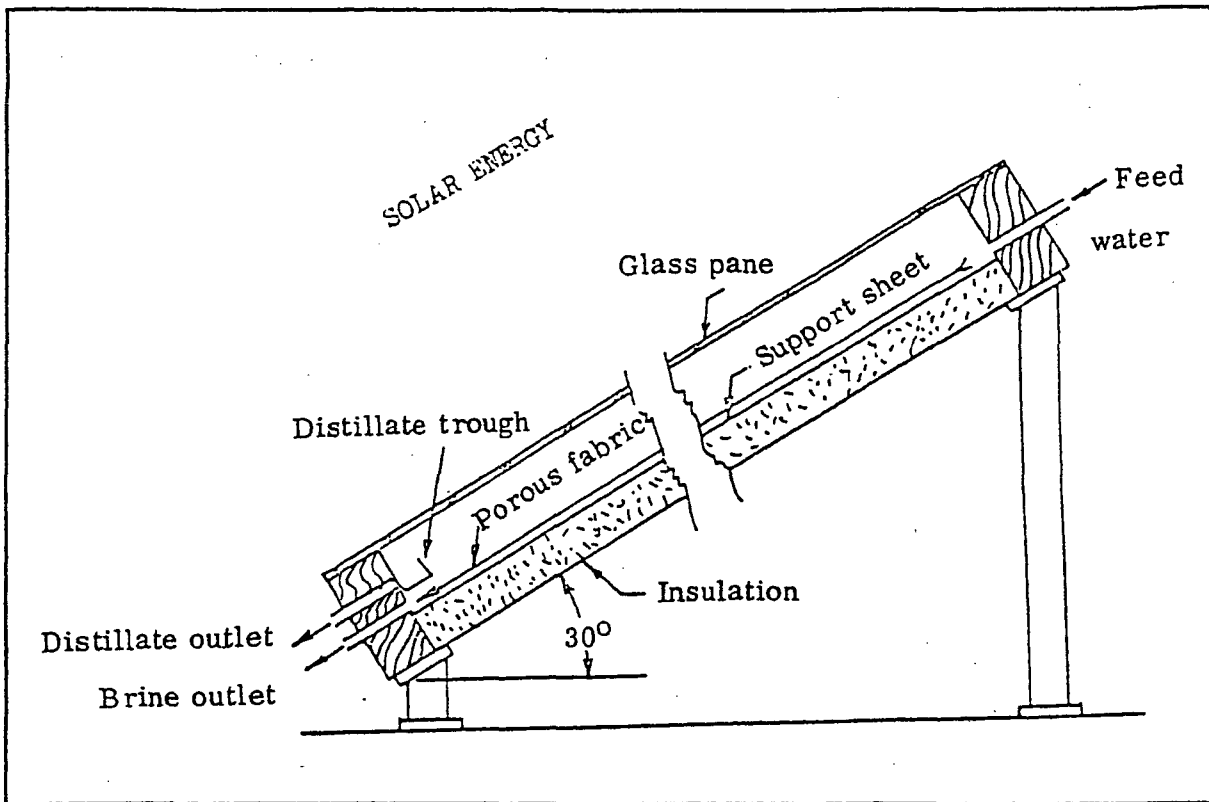

**Figure 6: Sloping wick solar still**

## 2.5 Chemical precipitation

Chemical precipitation (sometimes enhanced by biological processes) can be used in certain circumstances for desalination of water. The particular instances where this is possible are:

- \* hard waters (high in calcium and magnesium salts);
- \* any heavy metal contamination;
- \* high levels of fluoride;
- \* high levels of phosphates; or
- \* high levels of nitrates.

The process adopted in each case is different, but generally involves the addition of a chemical, allowing time for the chemical or biological reaction to take place, allowing removal of the chemical product, and final treatment (e.g. chlorination, stabilisation).

### 2.5.1 *hard waters*

In the case of hard waters, calcium and magnesium can be removed by increasing the pH of the water through the addition of lime, soda ash, or caustic soda. This will result in the formation of insoluble magnesium hydroxide and calcium carbonate salts that precipitate out of solution. This may require a two or even three stage process, with magnesium being removed at pH values above 11, calcium at pH values around 10, and then finally a neutralisation stage to bring the pH back to acceptable levels for drinking water. In a number of situations calcium is the main ion of concern, and can be reduced in a simpler process by passing the water through a filter bed of calcium carbonate (marble) chips. In all cases the process should first be tested in a suitable laboratory to ensure that the optimum process is selected.

The chemical processes may generally be described as follows:

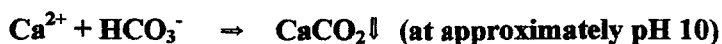
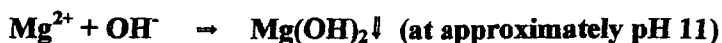

### 2.5.2 Heavy metals

Heavy metals are generally toxic, and should only be permitted at very low levels in drinking water. In cases where levels are high (usually due to some industrial pollution), the metal ions will need to be removed from the water before it can be considered fit for drinking.

Heavy metals are generally insoluble at higher pH values, and hence as for hard waters, can be removed by the addition of lime, soda ash or caustic soda. The process is similar to that for calcium and magnesium.



### 2.5.3 High levels of fluoride

Fluoride is normally reduced by the ion exchange process as described in section 2.1. However, the treatment of waters with very high levels of fluoride (>20mg/l) by ion exchange is significantly more costly than for lower levels. A portion of the fluoride can firstly be removed by chemical precipitation, and then the product treated by ion exchange. This could reduce the cost considerably.

The chemical precipitation process for the removal of fluoride (down to levels of approximately 10mg/l) is by the addition of alum (aluminium sulphate) - the conventional flocculent widely used in water treatment. The fluoride in the product will still not meet drinking water standards and will require the ion exchange "polishing" step.

### 2.5.4 Phosphates

Although phosphates are not generally of concern in drinking water, they may need to be removed from effluents (e.g. sewage ponds). Phosphates can be precipitated and removed by the addition of ferric salts (e.g. ferric chloride). The process would be similar to the flocculation process where ferric salts are used.

### 2.5.5 Nitrates

The removal of nitrates by chemical means is not a direct chemical addition process, but rather a biologically enhanced process. Nitrates in water can be considerably reduced by the biological conversion to nitrite and nitrogen. An additional carbon source may be required to provide the food required by the biological process.

### 3. FACTORS GOVERNING THE CHOICE OF DESALINATION SYSTEM

A number of factors must be taken into consideration when selecting an appropriate desalination system for a rural application.

#### *Alternative sources*

The first and most important of these is to assess whether there is not firstly an alternative source of water that can be accessed more conveniently. Desalination will always be a costly process even in the case of household solar stills, and hence any reasonable alternative source should be considered as a first option. An option usually always possible is rainwater collection from roofs that can be used as drinking water. However this may not always be practical or cost-effective.

#### *Proportion of water to be treated*

Where no reasonable alternatives exist, desalination must be considered. However at this stage a careful analysis of how much desalinated water is actually required must be made. Funds should not be spent on a desalination system that will supply all the water needs of a community when only 10% of uses require desalinated water. Where for example high nitrates or fluorides occur, only infants may need desalinated water and hence smaller systems could be set up at the local clinic to supply these lesser needs.

#### *Volume of water required*

The volume of desalinated water actually required will be an important governing factor for the selection of the most appropriate desalination technology. Where larger volumes are required, small household type solar distillation units become less attractive and more compact systems like reverse osmosis should be considered. The following table indicates typical water production range of the different technologies:

solar distillation	1 - 1000	ℓ/d
reverse osmosis	500 +	ℓ/d
electrodialysis	250 +	ℓ/d
ion exchange	20 - 5 000	ℓ/d
chemical precipitation	20 +	ℓ/d

#### *Institutional and operating skills*

The institutional and operating skills base in the community will be an important consideration in selecting a suitable technology. Reverse osmosis and electrodialysis systems require a high level of institutional and operating inputs to manage and sustain the system on an on-going basis. Solar distillation units do not require such skills and capacity, and can be household owned and managed. Family based systems have many advantages, but the technology offered must be of such a nature that people with little or no technical skills can operate, and to a certain extent maintain, the systems. Solar distillation systems, if properly designed and matched to the needs of the community, may be the optimum systems for such applications.

When larger quantities of water are to be treated on a community or large enterprise basis, the approach can be somewhat different. Certain technical capabilities of the operator can be assumed and combined finances will be available for the purchase, operation and maintenance of the system. However, it is still necessary to ensure that the system used is well matched to the capabilities of the community and the operators.



*Financial considerations*

Clearly financial considerations will always be an important consideration when selecting an appropriate system. This includes both the capital and the operation and maintenance costs. As already mentioned, economies of scale must be considered where larger quantities of water are required, but the operating costs must also be taken into consideration. Appendix A gives a method for estimating the capital and operating costs of a small-scale desalination system.

The following table gives some relative cost information for the various technologies:

Desalination System	Capital cost range R x 1000/ m <sup>3</sup> /d	O&M cost range R/household/month
Solar distillation	R 200 – R 300	R 5 – 10
Reverse osmosis	R 40 - 80	R 60 – R 120
Electrodialysis	R 50 – 80	R 50 – R 100
Ion exchange	R 50 – R 100	R 50 – R 120
Chemical precipitation	R 20 – R 100	R 50 – R 100

*Water quality*

Certain desalination systems are more suited to particular feed water salinity conditions. While distillation systems are able to handle most waters, including those with high salinity and scaling in nature, reverse osmosis and electrodialysis are less effective the higher the salinity, and are subject to fouling by more scaling waters.

**REFERENCES**

A large variety of manufacturer's literature and information sheets were used. However the following books and publications were also referred to and may provide useful additional reading:

Schutte CF 1983. Desalination: A South African Perspective. Water Research Commission

Benefield LD, Judkins JF and Weand BL 1982. Process chemistry for water and wastewater treatment. Prentice Hall, New Jersey.

Spiegler KS and Laird ADK 1980. Principles of desalination. Academic Press Inc., New York.

Schoeman JS, personal communication and various CSIR research reports.

Still D, MSC Thesis and personal communication re: solar distillation research.

APPENDIX A

DESALINATION COST SUMMARY SHEET

Location: \_\_\_\_\_ Capacity: \_\_\_\_\_ m<sup>3</sup>/d  
 Type of plant: \_\_\_\_\_ Plant life: \_\_\_\_\_ years Plant factor: \_\_\_\_\_  
 Source of feedwater: \_\_\_\_\_ TDS level: \_\_\_\_\_ mg/l  
 Recovery or performance factor: \_\_\_\_\_ Energy Source/fuel: \_\_\_\_\_

**CAPITAL COSTS**

Direct Capital Costs:

1.	Feedwater supply development	R	
2.	Feedwater treatment	R	
3.	Desalination equipment	R	
4.	Site development	R	
5.	Energy source development	R	
6.	Electrical equipment and switchgear	R	
7.	Disposal of brine	R	
8.	Product water storage and treatment	R	
9.	Other	R	
	<b>Subtotal direct capital costs</b>	<b>R</b>	<b>(A)</b>

Indirect Capital Costs:

10.	Interest during construction	R	
11.	Project management fees	R	
12.	Contingencies	R	
13.	Start-up costs	R	
14.	Other	R	
	<b>Subtotal indirect capital costs</b>	<b>R</b>	<b>(B)</b>

**Total Depreciable Capital Costs (A + B):** R (C)

Other Capital Costs (non-depreciable)

15.	Land _____ m <sup>2</sup>	R	
16.	Working capital	R	

**Total of Other Capital Costs** R (D)

**TOTAL OF ALL CAPITAL COSTS (C + D)** R

**UNIT CAPITAL COST (R/m<sup>3</sup>/d INSTALLED CAPAITY)** R /m<sup>3</sup>/d

**ANNUAL RUNNING COSTS**

17.	Labour – salaries	R	
18.	Labour – general & administrative overhead	R	
19.	Chemicals	R	
20.	Supplies and maintenance materials	R	
21.	Membrane replacement	R	
22.	Replacement of other equipment (e.g. pumps)	R	
23.	Special repairs or overhauls (contracted out)	R	
24.	Energy cost (electricity)	R	
25.	Energy cost (other)	R	
26.	Other	R	
	<b>Total Annual O&amp;M Costs</b>	<b>R</b>	<b>(E)</b>

**UNIT PRODUCTION COSTS (R/ m<sup>3</sup>/design capacity x plant factor)** R /m<sup>3</sup>

**WATER RESEARCH COMMISSION**

**A GUIDE TO:**

**PUMPS AND PUMPING SYSTEMS FOR  
RURAL  
WATER SUPPLY SCHEMES**

**PREPARED BY**

**DIVISION OF WATER, ENVIRONMENT AND FORESTRY  
TECHNOLOGY, CSIR**

## TABLE OF CONTENTS

1. INTRODUCTION .....	2
1.1 THE AIM OF THE BOOK .....	2
1.2 WHAT THIS BOOK IS ABOUT .....	3
2. TYPES OF PUMPS AND PUMPING SYSTEMS.....	4
2.1 Main Pump Types .....	4
2.2 Main energy sources for pumping.....	5
2.3 The Components of a Pump Installation.....	6
2.4 Typical Pump Installations for Rural Water Supply Schemes.....	7
2.5 Types of pumps .....	8
2.6 Types of Pumping Systems .....	16
<b>2.6.1 Grid Connected Electric Pumps</b> .....	16
<b>2.6.2 Fuel driven pumps</b> .....	16
<b>2.6.3 Solar Powered Pumps</b> .....	17
<b>2.6.4 Mechanical Wind Pumps</b> .....	20
<b>2.6.5 Hand pumps</b> .....	21
3. POWER REQUIREMENTS FOR PUMPS.....	24
4. IMPORTANT FACTORS AFFECTING THE CHOICE OF PUMPS .....	26
4.1 Technical considerations .....	26
4.2 Financial considerations.....	26
4.3 Scheduling of pumping hours.....	27
4.4 Type of power source.....	27
4.5 Operation and Maintenance needs .....	28
5. OPERATION, MAINTENANCE AND MONITORING.....	28
5.1 Monitoring of pump performance .....	28
<b>5.1.1 Short Term Testing</b> .....	29
<b>5.1.2 Long Term Monitoring</b> .....	29
<b>5.1.3 Periodic System Evaluations</b> .....	29
5.2 Operation and maintenance requirements.....	30
6. REFERENCES.....	31

# 1. INTRODUCTION

The water supplies to almost all communities need to be lifted by some means in order to transport the water to where it is required for use. Traditionally this has been done by carrying water in pots or jars, usually a task of the women in the community. With a desire and a need for a higher level of service and for more water to be provided to communities, this traditional means of transport is no longer appropriate, and alternative mechanical means for transporting water over distances and up hills have been developed. Although these pumps require increased inputs of energy, there are considerable time savings and improved convenience which can be made through pumping water. Hence pumps have become an important component of water supply schemes, greatly increasing the value of a water supply system in terms of improved access and wider distribution. It should be kept in mind, however, that the operation and maintenance of pumps often make up the major component of ongoing operation and maintenance costs.

Pumps are used in a large number of different applications for transporting water, and as a result a large number of different pump types have been developed to meet these different needs. When selecting a pump for a particular application, it is important to know what each pump type is most suited to, and under what conditions have they been designed to function. Suppliers of commercial pumps can provide information on the pumps they stock, but will require the user or purchaser to provide certain information on the specific application for which it is to be used.

It is a primary aim of this manual to help development agencies in the selection of pumps for the different applications for which water pumping is required, and to provide information on the operation and monitoring requirements which will ensure the longer term good performance of the pumps and engines.

## 1.1 THE AIM OF THE BOOK

This book is written for all rural development agencies who are involved in the development of water supply schemes which require pumping of water.

The primary aim of this manual is as a guide for the selection of pumps for the different applications for which water pumping is required, with special reference to the longer term operation and maintenance aspects of the pumps and engines.

The manual does not provide an exhaustive list of all pumps and pump types, but does indicate the broader categories of pumps which are applicable to rural water supply schemes, and provides guidelines for the consideration of the important factors which govern the long term sustainable operation of a pumping system.

The Handbook has as its primary focus, the support of rural development practitioners in the selection of appropriate pumps and pumping systems for development projects. Final selection must be made in consultation with actual pump suppliers who will have additional experience and knowledge of new methods and techniques. The Handbook may also be used as a training aid in courses addressing water pumping programmes.

## 1.2 WHAT THIS BOOK IS ABOUT

This book provides information on types of pumps that can be used for rural water supply schemes. It deals with the following aspects of pumps and pumping systems:

- the types and classification of pumps
- the power and energy needs of pumps
- the main factors influencing the choice of pumps
- how to plan and set up a pump operation and maintenance programme in a community
- how to determine the budget needs for the operation and maintenance of pump systems.

It is important to remember that although this book gives some guidance on pumps and pumping systems, new types of pumps are continually being introduced to the market. Furthermore sometimes a pump, which is appropriate in one application, may turn out to be inapplicable in a technically similar but socially or institutionally different situation.

It is always advisable to discuss the selection of a pump with an experienced pump contractor, engineer or pump supplier before making a final decision.

## 2. TYPES OF PUMPS AND PUMPING SYSTEMS

Pumps may be divided into four major categories according to their mode of operation. The different types are often suited to specific conditions, and are usually not applicable or efficient in all situations. Section 2.1 describes the main categories of pumps, section 2.2 the energy sources, section 2.3 the components of a pump installation, section 2.4 the typical application of pumps in rural water projects, and more detail is given in section 2.5 on specific pumps.

### 2.1 Main Pump Types

#### *Centrifugal pumps*

Centrifugal pumps impart a centrifugal force to the water through the rotary motion of an impellor. This outward acceleration forces the water through the outlet pipe while at the same time drawing in new water through the suction inlet. All centrifugal pumps have an optimum operating point where the characteristics of the impellor and pump casing are best matched to pump water efficiently. Figure 2.5 shows the typical performance characteristics of a centrifugal pump. It is important to select a pump that operates close to its optimum point to ensure minimum operating costs. For the pump to operate efficiently it is preferable to always maintain a positive pressure on the suction inlet. Pumps can be installed with the suction above the level of the water to be pumped or submerged below it. If the layout permits, it is good practice to install pumps with the suction submerged as this does away with the need to prime the pump before start-up. A submerged suction also helps to prevent cavitation, which occurs at the inlets to pump impellers when the pressure gets too low. The low pressure causes water vapour pockets to form. These vapour pockets collapse again suddenly as the pressure increases further into the impellor due to the impellor's pumping action. The sudden collapsing of the vapour pockets wears away the pump impellor and sometimes even the pump casing particularly when the impellor is not shrouded.

#### *Positive displacement pumps*

Positive displacement pumps function by means of a direct force on the water from the pump mechanism. A piston pump is a good example of this, where the water is forced into the pipe by the piston moving up the cylinder. Because of this means of operation, positive displacement pumps have a very uniform performance relationship with little variation in efficiency as compared to a centrifugal pump.

#### *Suction pumps*

Suction pumps function specifically to lift water over short distances (less than 5m). For shallow wells suction hand pumps can pump water out of the well with the main pump mechanism being all located at the surface of the well. Suction pumps should not be used with a positive head on the delivery side of the pump, and cannot lift water more than approximately 5m (the vapour pressure of water).

*Air or water jet pumps*

Air pumps function by “air lifting” water up a pipe. This is carried out by simply pumping air into the pipe at a point below the static level of the water. As the air rises up the pipe, it carries the water with it, pumping it up to the point where the air escapes to the atmosphere. In South Africa certain wind pumps operate effectively on this principle.

Water jet pumps operate on a similar principle, except that a stream of water is pumped through a jet nozzle and venturi within the water to be pumped. The venturi draws external water into the jet stream through causing a suction, while the jet itself also imparts momentum to the main water body and carries it up the pumping main. As with air pumps, no delivery head can be permitted above the outlet of the jet pump mechanism.

## 2.2 Main energy sources for pumping

There are also six main types of energy source used for operating pumps. These are

*Hydraulic energy*

Hydraulic energy is obtained from water flowing downhill, usually within a closed pipe. This energy can be converted into mechanical pumping energy through a piston mechanism (called a hydraulic ram), or by turning a wheel or impellor (water wheel or turbine). This mechanical energy can be used directly to operate a pump, or be converted into another form of energy (e.g. electrical energy).

*Wind energy*

Wind energy is a low-cost form of energy readily available in many areas. In South Africa wind energy has been used for many years to operate windmills or wind pumps. More recently wind energy has been harnessed to drive generators (producing electricity) and air compressors (to operate air pumps).

*Solar energy*

Solar energy collection systems (solar cells) are now well developed and, although still costly, have been used for many pumping installations. Solar cells are used to produce electricity that is used to drive a pump.

*Animal and man power*

Certain pumps have been designed specifically to be operated by human or animal power. Ancient civilisations have used this form of energy for centuries for pumping water, and some of these are still in use today. In South Africa handpumps may be found in many rural areas. In general these are easy to operate by men, women and children alike. Animal power is not so widely used anymore, although the University of Fort Hare have a centre of expertise specifically around the use of animal power in rural environments.



*Chemical energy (stored in fossil fuel)*

Chemical energy is contained in fossil fuels. This energy is used to drive engines, which in turn drive pumps. Diesel engines are used widely in rural areas for pump installations.

*Electrical energy (from the national grid)*

Electrical energy is one of the most convenient forms of energy to employ for pumping. It can be readily taken to any pump installation via overhead power lines, and once installed is always available at the point of use. However it is not always ideal for rural pumping installations because a line fee is usually charged on a monthly basis whether electricity is used or not. Many communities have found themselves with huge debts when their installation broke down and they did not use the engine for a few months. During this period no tariffs were collected because no water was provided, but the electricity account continued to mount up monthly.

**2.3 The Components of a Pump Installation**

The pump and the prime mover (energy source) are linked together to form a pump system. A pump system includes the pump, the prime mover (energy source), the water source from which the water is pumped, the end point of the pumping main, the pipe work on both the suction side and the delivery side of the pump, and the valves, meters and other ancillary devices connected into the pipe work. It is very important that pump designers consider all the components of a pumping system and ensure that they are compatible with each other.

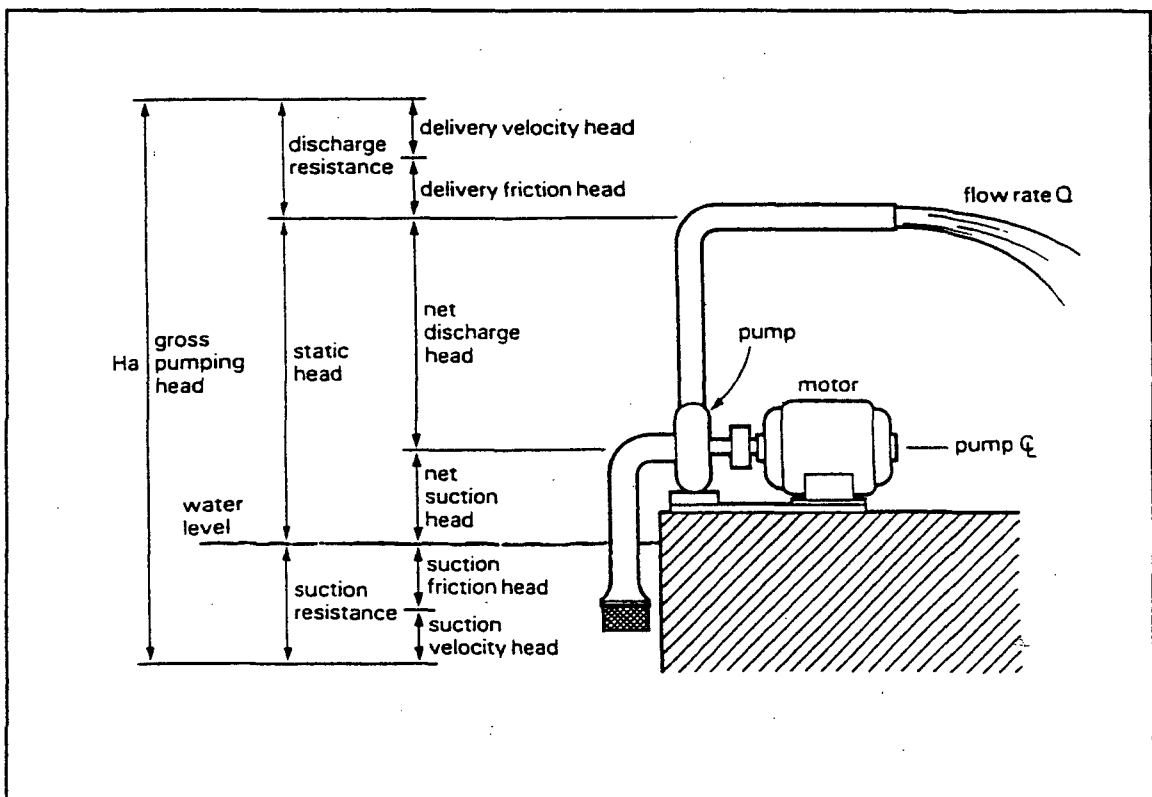

**Figure 2.1 Components of a typical pumping system**

The total pumping head is made of the following components:

- static head – the difference in height between the level of water being pumped and the outlet of the pumping main
- pipe friction – as water travels through the pipe the friction of the pipe causes a drag on the flow of water, called the friction head. (friction will be felt in both the suction pipe and the delivery pipe)
- water velocity – water flowing at a certain velocity has energy, called the velocity head. Both the water flowing in the suction pipe and in the delivery pipe will have a velocity head component.

The pump must have sufficient capacity to provide for all of these components of the total pumping head. Note also that pipe friction increases as the velocity increases, and with any bends, valves or other constrictions in the pipelines.

## 2.4 Typical Pump Installations for Rural Water Supply Schemes

For rural water supply schemes, water sources may be from a borehole, a storage dam or directly from a stream. The following are typical pumping arrangements for these applications:

### *Boreholes*

A positive displacement or centrifugal pump is fixed below water level down the borehole. In this case the suction pipe is the inlet of the pump itself (through a screen). The water is pumped out the borehole and then usually some distance further to a storage reservoir. The prime mover for borehole pumps may be any of electricity, fossil fuel (diesel), man or animal power, wind or solar power.

### *Storage dams*

The pump is usually installed outside of the reservoir, connected via a screened suction pipe to the bottom of the reservoir. The pump is usually a centrifugal pump pumping into a long delivery pipeline that feeds another reservoir at a higher elevation. The prime mover is usually an electric engine or a diesel engine.

### *Stream or river*

Usually an in-stream sump or off-stream channel or sump is constructed from which the water is pumped. Some form of flood protection is required, or else the pump must be easily disconnected so that it can be moved to higher ground. Pump requirements often call for a pump with capacity to be able to pump some sand or silt. Certain centrifugal pumps have been specially designed with this capacity. Hence in most cases centrifugal pumps are the pump of choice. The pump may either be submerged in the sump or channel, or be connected via a short screened suction hose. The delivery line may be short or long, again delivering the water into a storage reservoir. The prime mover is usually an electric engine or diesel engine.

## 2.5 Types of pumps

The distinction between types of pumps lies not so much in the mode of application of the pump, but in the principles of operation of the pump. Pumps may be divided into the following three major categories:

positive displacement pumps  
centrifugal or turbo pumps  
direct lift devices

### Positive displacement pumps

Water is for most practical purposes incompressible. Therefore water can be displaced by drawing a close fitting piston through a pipe full of water, or by pushing a solid object into the water so that the water around it is displaced in the direction of least resistance. Pumps working on this principle are known as positive displacement pumps.

Most pumps fall into this category. However, since a number of these fall into turbo pump category with particular characteristics, they have been separated out here for ease of reference. Hence positive displacement pumps in this sense refer to:

piston pumps,  
diaphragm pumps, and  
rotary spiral screw pumps

Positive displacement pumps are designed to deliver water from a source to a point at a higher elevation or against pressure. Pressurising the water and feeding it into the delivery pipe under pressure, or by reducing the delivery pressure such that gravitational pressure is sufficient to drive the water into the delivery pipe accomplish this. The latter pumps are also referred to as suction pumps.

Certain of the piston pumps known as net positive suction head pumps (or suction pumps) rely on atmospheric pressure to push water into the suction pipe of the pump. The pump reduces the atmospheric pressure on the water in the suction pipe and the atmospheric pressure on the water outside the suction pipe pushes the water up. The difference in level between the

**Figure 2.2: Typical positive displacement piston pump (Fraenkel 1986)**

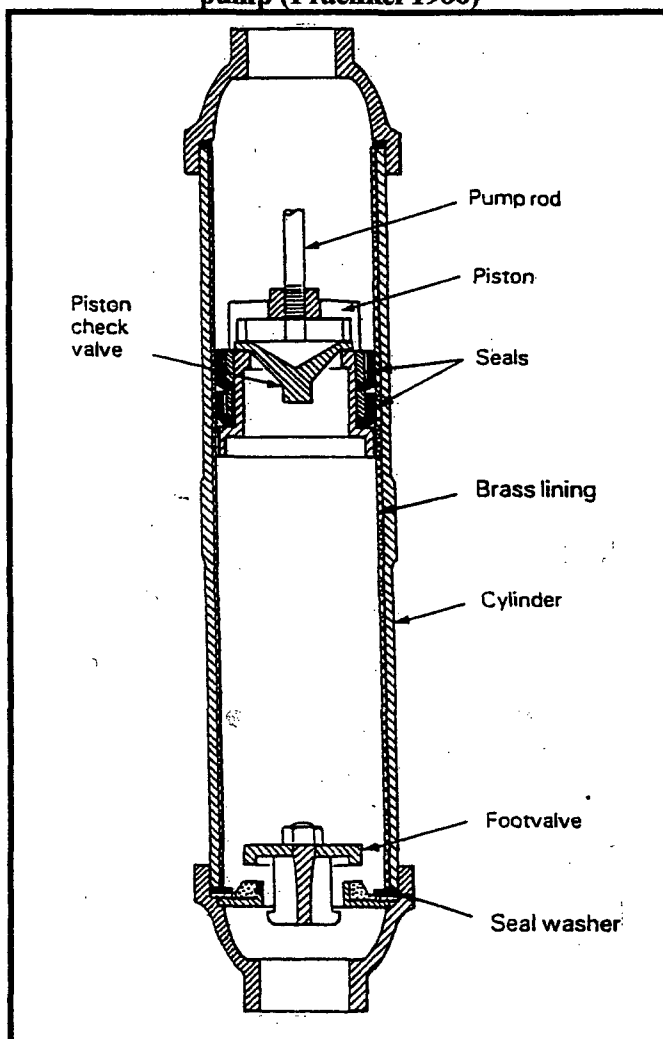

pump and the level of the water to be pumped is determined therefore by the negative suction pressure exerted by the pump in the suction pipe relative to atmospheric pressure. Normal atmospheric pressure at sea level is about 1 bar = 100 kPa. This pressure is theoretically sufficient to support a column of water of 10,19 metres under a perfect vacuum (zero pressure). In practice since no pumps are perfect, atmospheric pressure limits pumping depths to 7 metres at sea level (or 6 m at 1100 m elevation). Many pump suction can only effectively handle suction depths of about half those quoted above due to leaking valves and seals. Therefore applications of suction pumps are restricted to shallow depths. They are sometimes referred to as shallow pumps.

### Rotary spiral screw pumps

The principle of operation of this pump is that a spiral rotor is rotated inside a close-fitting stationary casing called a stator. As the rotor turns, it increases the pressure of the water by creating a progressive cavity which 'screws' the water in the direction of flow. These types of pumps are used in a number of applications, the most well-known being the rotary borehole pumps which are common in Southern Africa. A cross section of this pump is shown in Figure 2.3.

**Figure 2.3 Rotary spiral screw pump  
(Fraenkel 1986)**

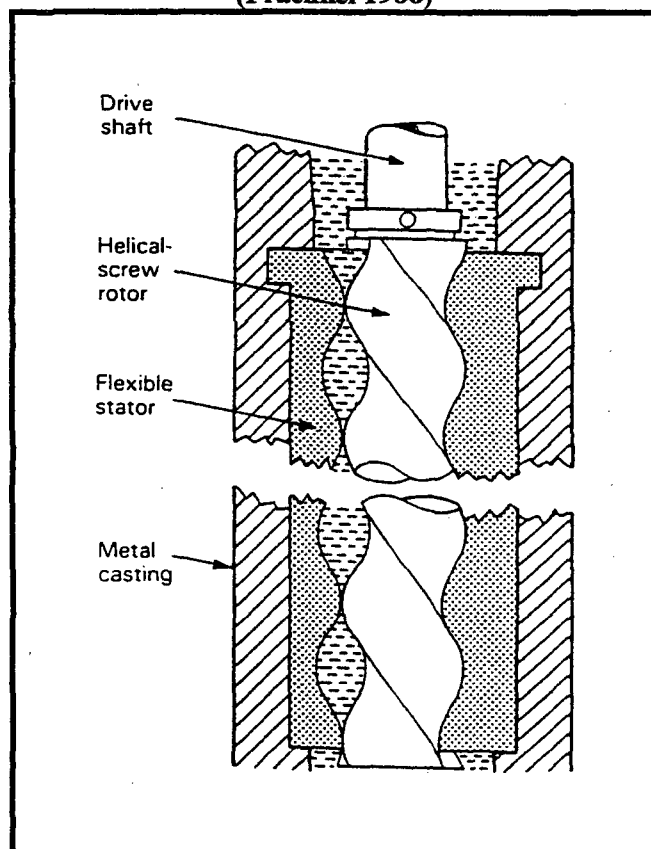

These pumps, which are referred to as helical rotor, progressive cavity, screw or worm pumps, deliver water in a steady stream. The flow rate can be adjusted by adjusting the speed of rotation, with a maximum speed under normal circumstances of 1200 rpm. These pumps can be easily primed from the delivery pipe and have good suction characteristics. The chief manufacturer of all types of rotary screw pumps in South Africa is Mono Pumps (Pty) Ltd. Diesel driven engines and electrical motors are suitable for driving this type of pump, with some being designed for hand operation. Internal losses in rotary pumps is usually higher than in reciprocating pumps through slip (internal leak-back). Since slip increases with increasing pressure, rotary pumps are less suited to high pressure systems. When these pumps are used to pump against a head of 75 m or more, a gear device should be provided at the drive to reduce the power requirements when starting the pump.

### Centrifugal pumps (Roto-dynamic pumps)

The so called centrifugal or roto-dynamic pumps propel water using a spinning impeller or rotor. Pump manufacturers usually produce a wide range of centrifugal pumps to cover a wide range of heads and flows. Pumps in this category include:

- axial flow pumps,
- centrifugal pumps,
- multi-stage submersible centrifugal pumps.

These pumps are all driven by an engine

Centrifugal pumps use impellers to displace fluids like water by momentum rather than by positive mechanical travel. Hence output is dependent on impeller speed and on discharge head. Typical operation speeds range from 1500 to 3000 rpm. Low speed centrifugal pumps can be expected to wear less and last longer than high speed pumps.

These operate by rotation of impellers or screws within a pump body or casing. Large size screw type mixed-flow axial pumps are suitable for large flows at low pumping heads. Where high pumping heads are to be dealt with, multi stage pumps are used; each stage of the pump comprising casing and impellers which progressively raise the pressure and hence the hydraulic potential energy of the water. They can be installed in various ways according to local conditions. The axis of the pump can be mounted vertically or horizontally. The suctions can either be above the level of the water to be pumped or below (submerged suction). In each situation basic data of lengths, heights, size of pipe etc. are required in order to predict the operating characteristics of the selected pump and to design the pump installation.

While it is possible to use one pump for a number of applications, centrifugal pumps tend to have a fairly narrow application range at which their efficiency is optimum. Using a pump out of this range results in higher operation and maintenance costs, and perhaps more down times.

Each centrifugal pump has a maximum efficiency corresponding to a particular value of discharge  $Q$ , head  $H$ , and speed  $N$ . The curves drawn for discharge versus  $H$ ,  $N$  and efficiency  $e$  are known as characteristic curves (figure 2.7). The most suitable pump for a particular application is one whose efficiency is a maximum at the operating values of head and flow rate.

Pump speeds of up to 1500 rpm should be chosen for raw water pumping, with speeds up to 2900 rpm for clean water with no suspended solids, or for pump openings of 200 mm or more. The capacity of the pump is directly proportional to the speed.

When buying a pump it is always advisable to send potential pump suppliers details of the net positive suction heads available and the gross pumping heads for different flow rates at the system's maximum and minimum static heads. This is important to ensure that the pump supplied matches the full range of operating conditions it encounters. For example if the static head remains constant and the gross pumping head is not too high it is likely that a simple end-suction pump like the one shown at the bottom right of figure 2.6 will be suitable for the task. Figure 2.4 illustrates how in this case the rather flat characteristic curve of such a pump with an impeller with long radial vanes neatly crosses the system characteristic curve.

**Figure 2.4 Centrifugal pump with a flat characteristic curve operating on a system with a fixed static head**

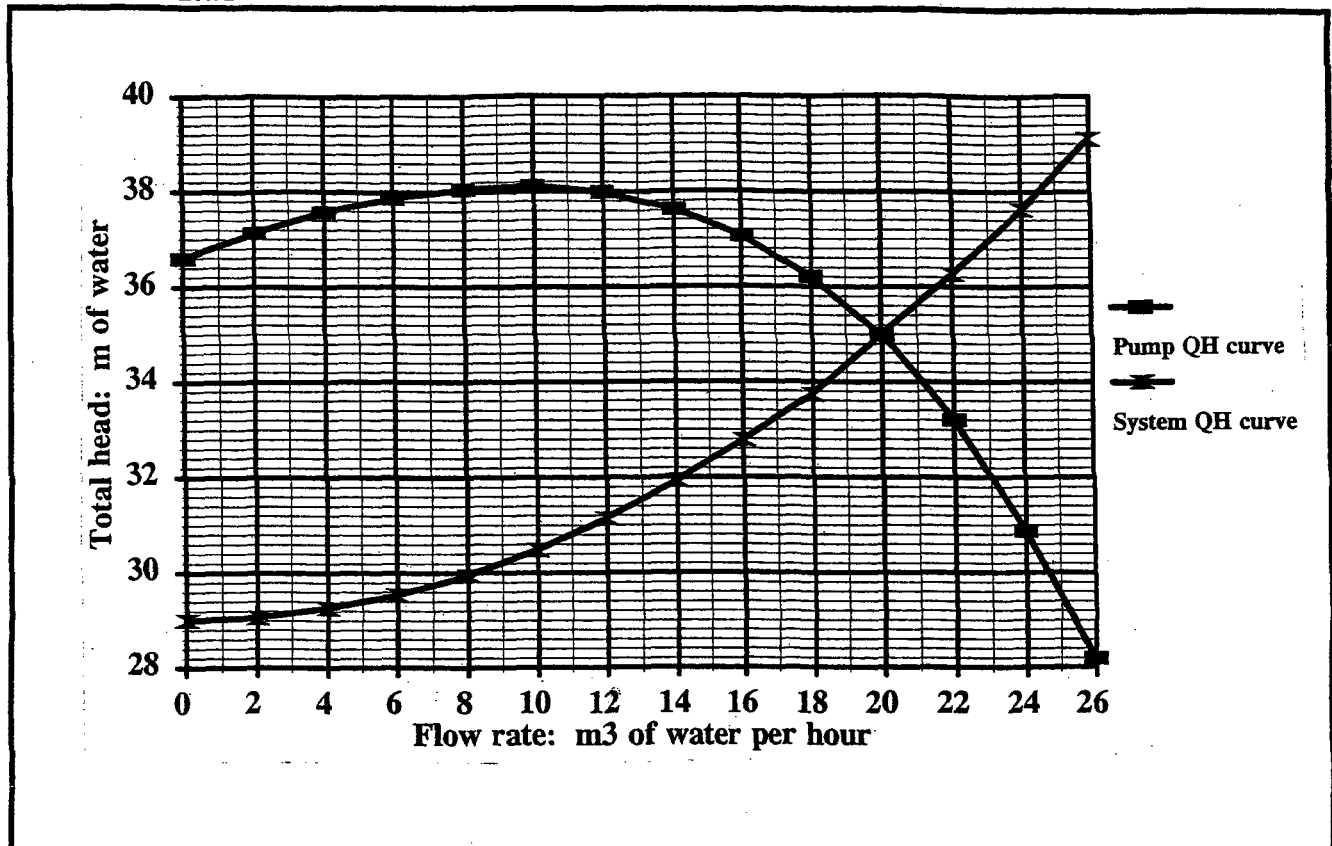

However it often happens that the static portion of the total head does not remain constant because the pump is drawing water from a bulk supply line in which the suction head is varying or because it is drawing water from a borehole the level of which varies with time. On the delivery or discharge side of the pump (refer figure 2.1) the static head can also vary and even the friction head can vary for the same flow if, for example, customers are supplied with water directly from the pump delivery line before it goes into the reservoir. When this happens the system has an envelope of characteristic curves varying from the maximum static head with no customers drawing water from the pump's pipeline to the minimum static head with the maximum draw-off by customers from the pump's pipeline. Such a system is shown in figure 2.5.

Figures 2.4 and 2.5 have the same pump design duty point, 20m<sup>3</sup>/hr against a total or gross pumping head of 35 in. However, if the pump chosen for the system depicted in figure 2.4 was purchased to operate on the system depicted in figure 2.5 it could not operate on either the maximum or minimum system characteristic curves. Thus for the system depicted in figure 2.5 it is necessary to buy a more expensive multi-stage pump, perhaps a 4 stage pump similar to the pumps shown at the bottom left of figure 2.6. Such a multi-stage pump has a number of mixed flow impellers in place of the single radial flow impellor of the pump chosen for the system depicted in figure 2.4.

A pump and a system are said to be perfectly matched flow-wise when the pump curve crosses the system curve at the QH point at which the pump operates at its maximum efficiency. rj.

Figure 2.5: Centrifugal pump with a steep characteristic curve operating on a system with a varying static head and varying friction head curve

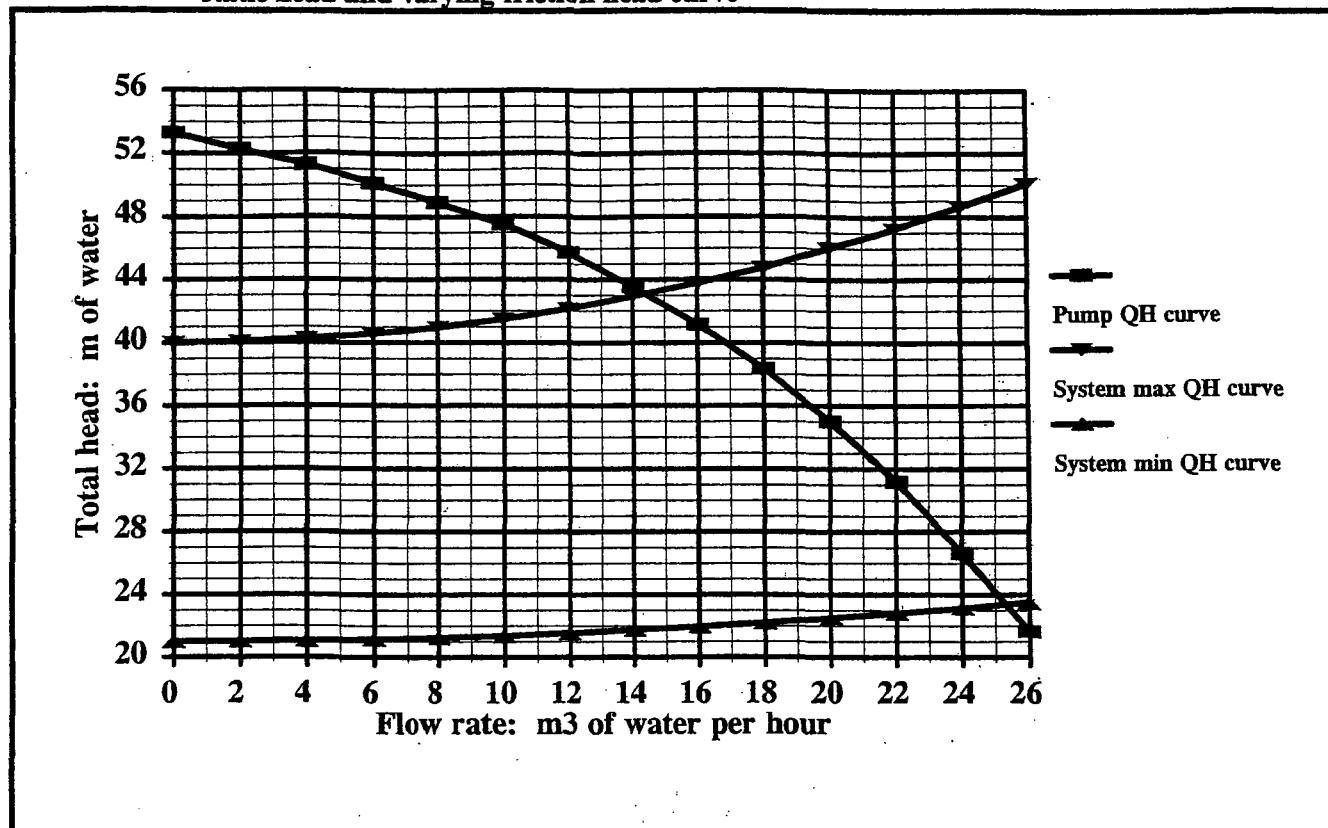

Generally such a perfect match is not possible. However this is not a problem since nearly all centrifugal pumps work satisfactorily as long as they are operating at a flow which is between 50 % and 115 % of the pump's flow at its maximum efficiency point. At lower flows pumps tend to vibrate badly and damage their bearings. This is especially of pumps with a steep characteristic curve. At very low flows or no flow all pumps will overheat because of the high recirculation and churning losses. At higher flows pumps tend to wear excessively and cavitate unless the suction head is exceptionally high. This is particularly true of double suction split casing pumps and pumps with flat characteristic curves.

Thus more generally the most suitable pump for a particular application is the one with maximum efficiency point closest to the design duty point and with a characteristic curve which comfortably straddles the full envelope of the system's characteristic curves. High-speed pumps often have higher efficiencies but, as stated on page 10, low speed pumps usually wear less and last longer than high speed pumps. For pumps having a suction inlet up to a maximum of about 150 mm. speeds of up to 2900 rpm can be considered when clear water with no suspended solids is being pumped. For all other applications pump speeds should be limited to 1450 rpm.

Because of the importance of matching a pump with the actual operating conditions, static heads and friction losses should be calculated as realistically as possible without any safety margin even if a safety margin was used when the pipe sizes were selected. In designing the pumping

system it is also important to install sufficient isolating valves to facilitate maintenance work. Other important items are a scour valve at each low point and sufficient air valves, including one at each high point, to ensure that any air in the pipeline is expelled speedily. A very important criterion which is often forgotten during pipeline design is ensuring that no point on the pipeline ever goes below atmospheric pressure over the full range of normal operating conditions. Such a check is particularly important when the pipeline is being installed in hilly countryside.

When a system's envelope of characteristic curves become so variable that it is impossible to purchase a centrifugal pump with a characteristic curve capable of performing all the required duties it is often practical to use a rotary spiral pump as described on page 7 and illustrated in figure 2.3. Another solution is to buy a variable speed drive for the pump. Such drives work well but are expensive and require sophisticated controls or an attentive well trained operator. When the speed of a pump is changed its new flow is directly proportional to the ratio of pump speeds, its new head is directly proportional to the square of the ratio of pump speeds and, consequently, its new absorbed power is directly proportional to the cube of the ratio of pump speeds.

Another reason why pump suppliers should be given full details of the system in which a pump is to operate is to make sure that the power source supplied to drive the pump is sized to cater for the full range of operating points at which the pump may operate. For pumps with steep characteristic curves, like the one shown in figure 2.5, the starting torque of the power source may also have to be chosen carefully. Overload protection should be installed with practically every form of pump drive. If this protection operates frequently after the pump has been commissioned never remove, bridge out or de-activate the protection. This would expose the operator to unsuspected danger and is likely to cause unnecessary damage to the pump's prime mover that will not even be covered by the supplier's guarantee.

**Figure 2.6 Typical centrifugal pumps**

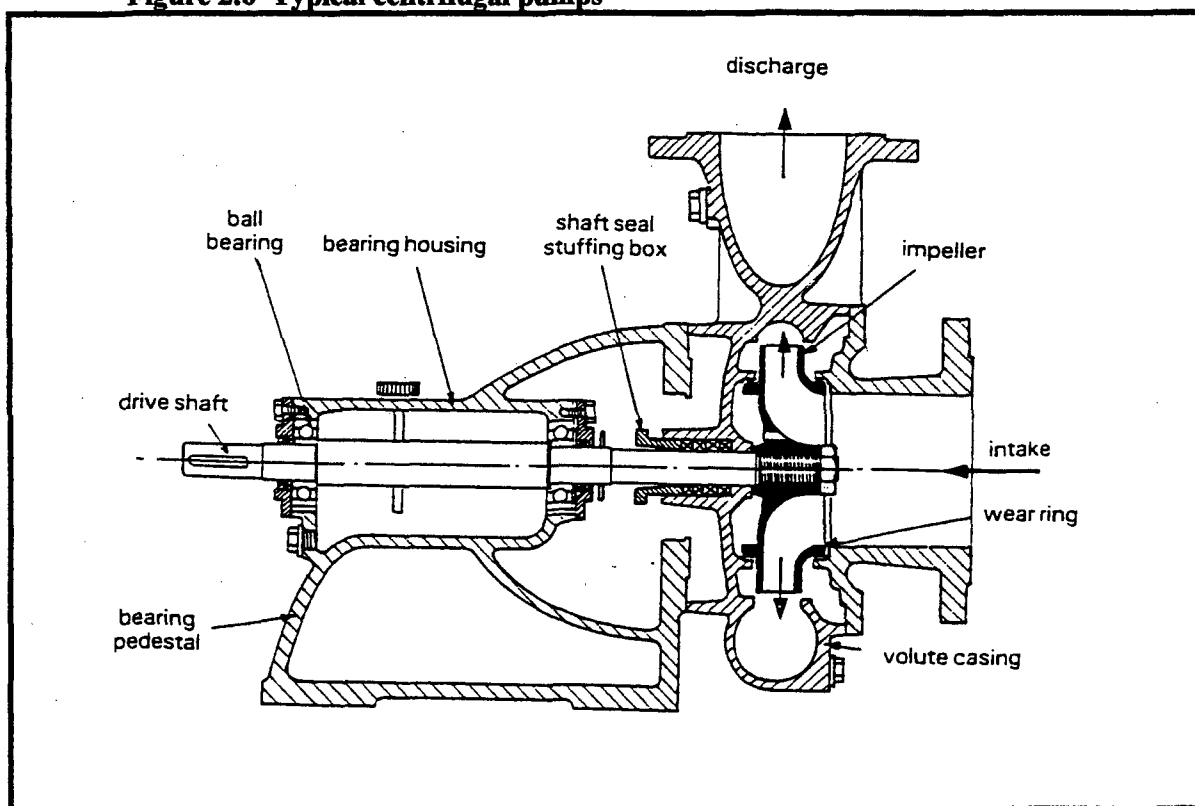
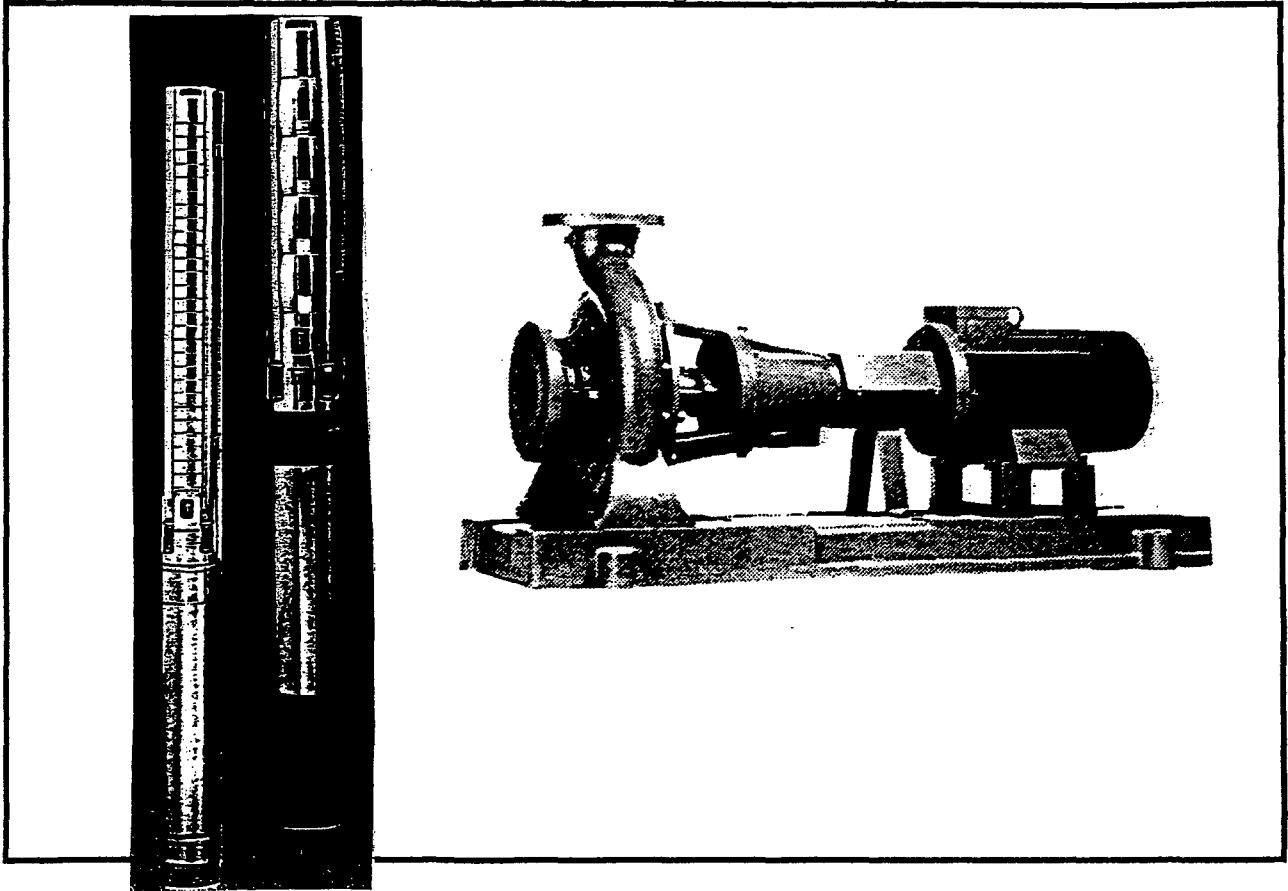



Figure 2.6a Typical centrifugal pumps – single and multi-stage



### Direct lifting devices

These water lifting devices include buckets, levered scoops, windlasses, and rotary bucket lift systems. They are usually operated by man or animals, although they could be mechanised in certain cases. The flow from any of these devices is a function of the volume of each bucket, and the speed at which the buckets are raised. The flow is usually intermittent, or at best pulsationary. A number of such devices have been developed over the world during the last centuries. Devices still in use include:

- the shadouf, and dall,
- Archimedian screw,
- Persian wheel,
- chain or rope pumps,
- Mohtes, and
- bucket hoists.

These types of pumps are not used to any significant degree in South Africa, but have been in use for centuries for irrigation in some countries.

Figure 2.7 Typical characteristic curves for a multistage centrifugal pump

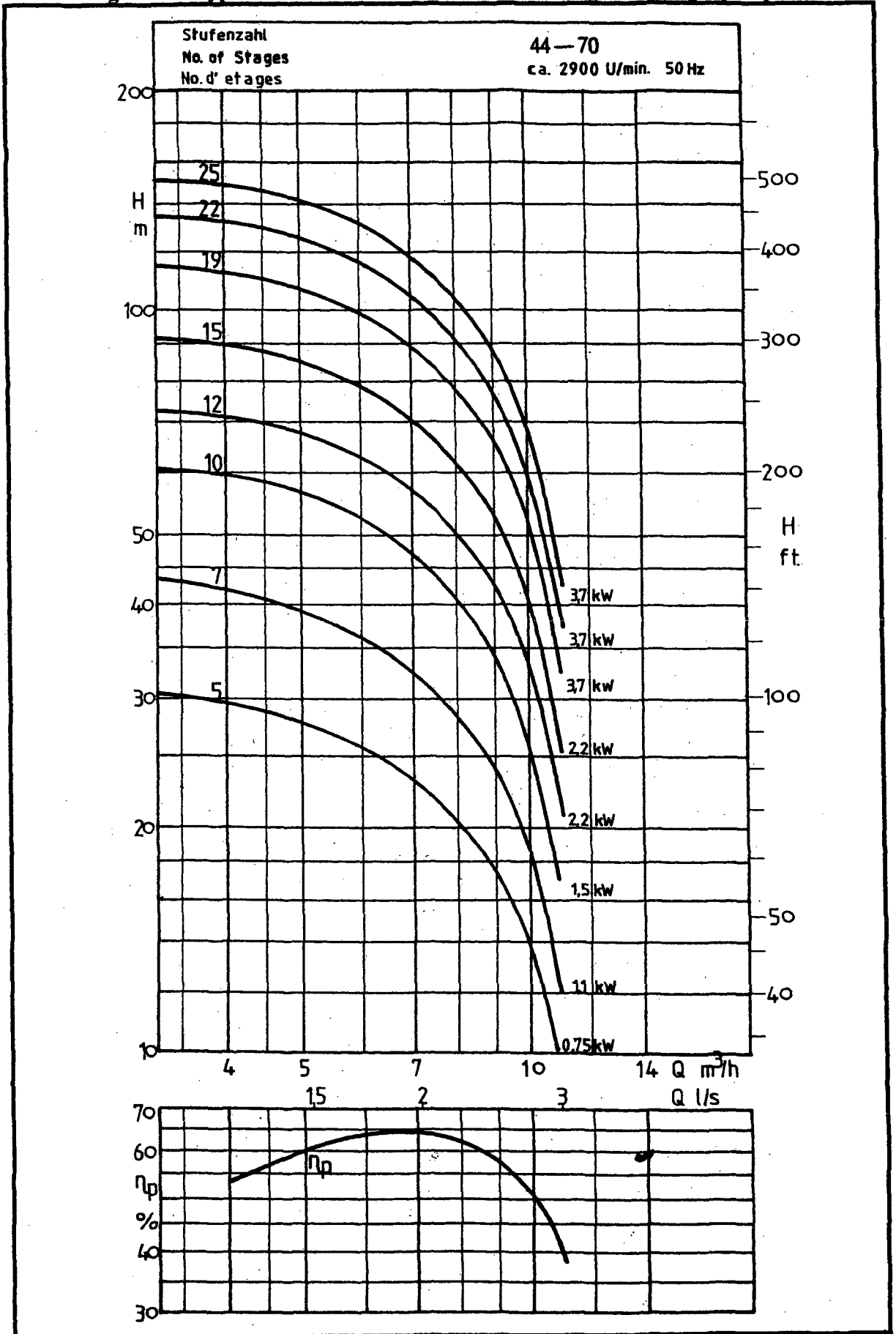

## 2.6 Types of Pumping Systems

### 2.6.1 Grid Connected Electric Pumps

When the supply of electricity from grid supplies is reliable, electric pumps may be the most convenient and cost effective of all pumping systems. Electric powered pumps could also be supplied from non-grid sources such as small generators, batteries, or solar panels (dealt with in 2.3). However because of the convenience of a grid electricity pumping system, developers will usually strive to achieve this level of pumping system if the grid power lines are within a reasonable distance of the pump installation.

One of the important advantages of electric pumps is that their operation and control can be more automated, with low and high water level switches, timers, and other recorders.

Electric pumps can be used for almost any pump installation, including the following typical applications for rural water supply schemes:

- borehole pumps (both down-the-hole types and surface driven);
- low-lift high-volume surface water pumping (e.g. from a river or dam to the head of a water treatment plant);
- intermediate-lift high-volume surface water pumping (e.g. from a clear water storage reservoir at the end of a treatment plant to a distribution reservoir);
- high-lift low volume pumping (e.g. from deep borehole to a reservoir serving a small population situated at an elevation much higher than the source).

### 2.6.2 Fuel driven pumps

In areas where no grid electricity is available, the almost universal power source used for pumping is the internal combustion (I.C.) engine, usually using diesel fuel. Diesel engines are as a rule more reliable than petrol engines.

One of the most popular diesel engines for pumping water has been the English Lister diesel engine which comes in a range of sizes from 3,3 kW to 94,0 kW continuous power output (speeds range from 1000 to 2500 rpm). However there are now a number of other stationery diesel engines available in South Africa, include Robin, and Kubota Ltd, both manufactured in Japan. Small petrol engines suitable for pumping are available from Honda, Robin and Koshin Ltd, all of Japan with power outputs varying between 1 kW and 7,5 kW depending upon model and speed.

The diesel engine is better suited to running for long hours than petrol engines, and are more efficient than petrol engines. However petrol engines are more light-weight if portability is important, and are easier to maintain. The following table (after Fraenkel 1986) compares the different small I.C. engines.

**Table 2.1: Comparison between different IC engines for pumping (Fraenkel 1986)**

	petrol	kerosene/ paraffin	diesel high speed	diesel low speed
average fuel to shaft efficiency %	10 - 25	10 - 25	20 - 35	20 - 35
weight per kW of rated power	3 - 10 kg	4 - 12 kg	10 - 40 kg	20 - 80 kg
operational life (typical)	2000 - 4000h	2000 - 4000h	4000 - 8000h	8000 - 20000h
running speed (rpm)	2500 - 3800	2500 - 3800	1200 - 2500	450 - 1200
typical daily duty cycle (h)	0.5 - 4	3 - 6	2 - 10	6 - 24

When specifying an engine for use with a particular pump, it is always advisable not to choose an engine with a maximum power rating equal to that required by the pump. Instead, the engine power rating should be 70 to 80% of the pumping power requirements. This reduces the wear of the engine and usually improves the efficiency. However an engine which is very much bigger than the pump power requirements should be avoided as the engine efficiency will be much poorer than under optimal conditions, and the engines tend to build up excessive carbon deposits in the cylinder (called coking).

Fuel driven pumps can be used for a number of different pump installations, including the following typical applications for rural water supply schemes:

- borehole pumps (surface driven);
- low-lift high-volume surface water pumping (e.g. from a river or dam to the head of a water treatment plant);
- intermediate-lift high-volume surface water pumping (e.g. from a clear water storage reservoir at the end of a treatment plant to a distribution reservoir);
- high-lift low volume pumping (e.g. from deep borehole to a reservoir serving a small population situated at an elevation much higher than the source).

However fuel driven pumps cannot be used in very confined spaces such as down a borehole or in a small sump.

### 2.6.3 Solar Powered Pumps

Solar powered pumps have significant potential for use in rural water supply schemes. However the high capital cost and general unfamiliarity are the main barriers to their wider use. There have been a number of successful applications of this technology in South Africa where the cost effectiveness and reliability have been proven.

There are two main methods by which solar pumps function. The first is through the direct use of the heat to drive a steam or Stirling engine, while the second (and most common) is the conversion of solar radiation to electricity by means of photovoltaic cells.

Steam or Stirling engines are very seldom used these days, but there have been a few new designs which use the solar heat energy directly for pumping water. These have not been fully tested and proven, but may become viable options in the near future.

The electricity produced by photocells is in the form of direct current (DC). Most electric pumps use alternating current (AC), and it may therefore be necessary to convert the DC to AC. A DC/AC inverter is used to convert direct current to alternating current. Alternatively there are a limited number of DC pumps and engines available, and if one of these were suited to the application, it would be more cost effective to use one of these engines with the solar panels. Figure 2.8 illustrates a typical solar pumping installation.

**Figure 2.8: Typical solar pumping system – a) borehole & b) pumping from a sump**

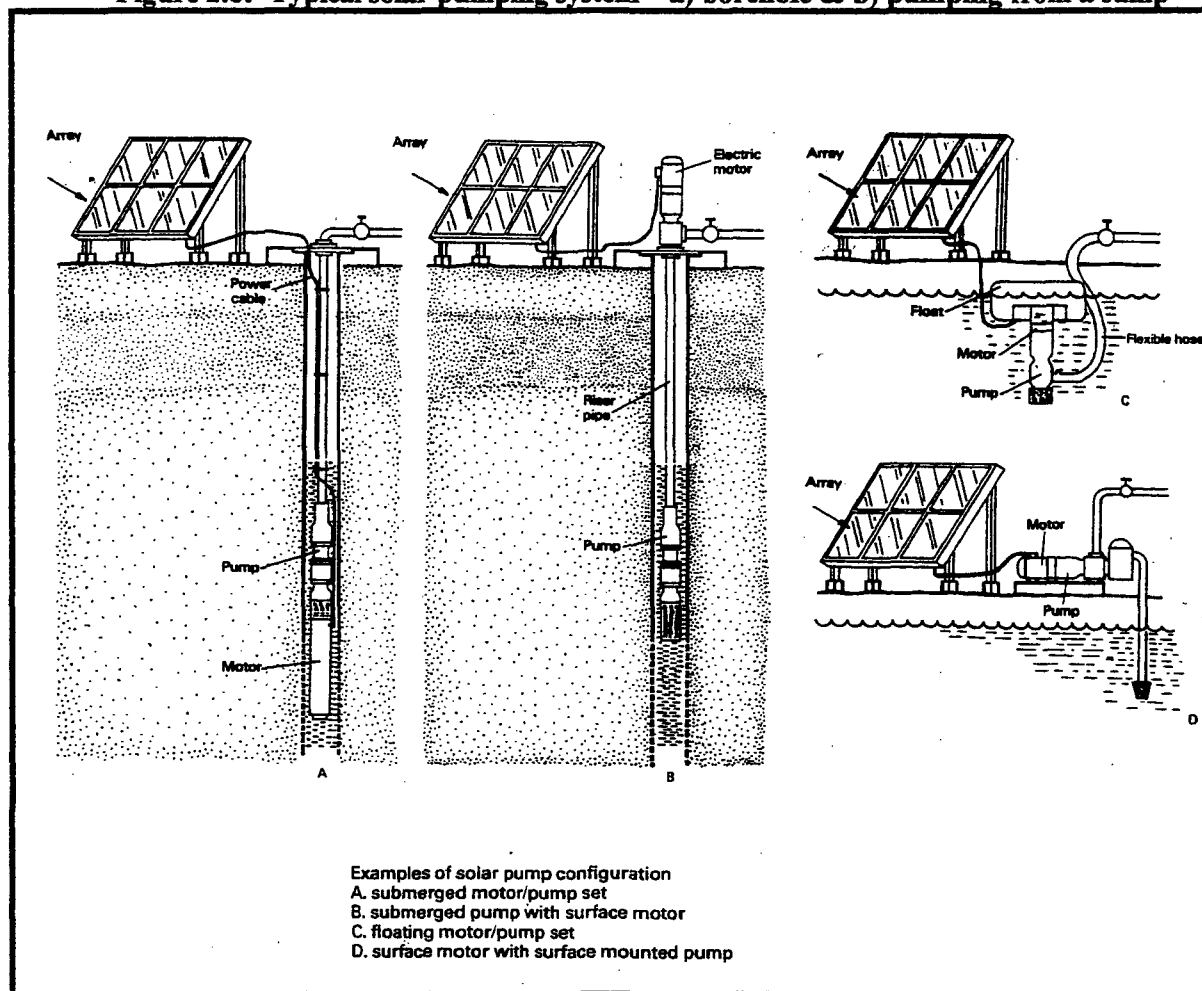

Note that because solar energy is not constantly available, solar pumping systems will usually include some storage facilities, either for water (reservoir) or for electrical energy (batteries), or both. Furthermore the movement of the sun through the day means that the

photovoltaic panels will not receive direct irradiation except for a short period of the day. Consequently the solar panels are tilted at an angle to the sun to allow the most radiation over the whole day. The angle of the tilt should be adjusted between summer and winter. The average angle of tilt at any particular place is equal to the angle of latitude at that location.

The efficiency of solar cells declines as the cells get hotter, with approximately a 1% loss of efficiency for every 10°C rise in temperature. This is highly significant since the efficiency of solar energy conversion by photovoltaic cells is only in the region of 10%. Therefore with most solar panels operating at temperatures of 50 - 60°C, the actual power output may only be 70% of that (quoted by the suppliers) at say 25°C.

Solar pumps can be used for almost all the installations for which electric pumps could be used, including the typical applications for rural water supply schemes.

The following diagram shows the necessary and optional components of a photovoltaic pumping system:

**Figure 2.8: Components of a photovoltaic solar pumping system (dashed lines indicate optional linkages)**

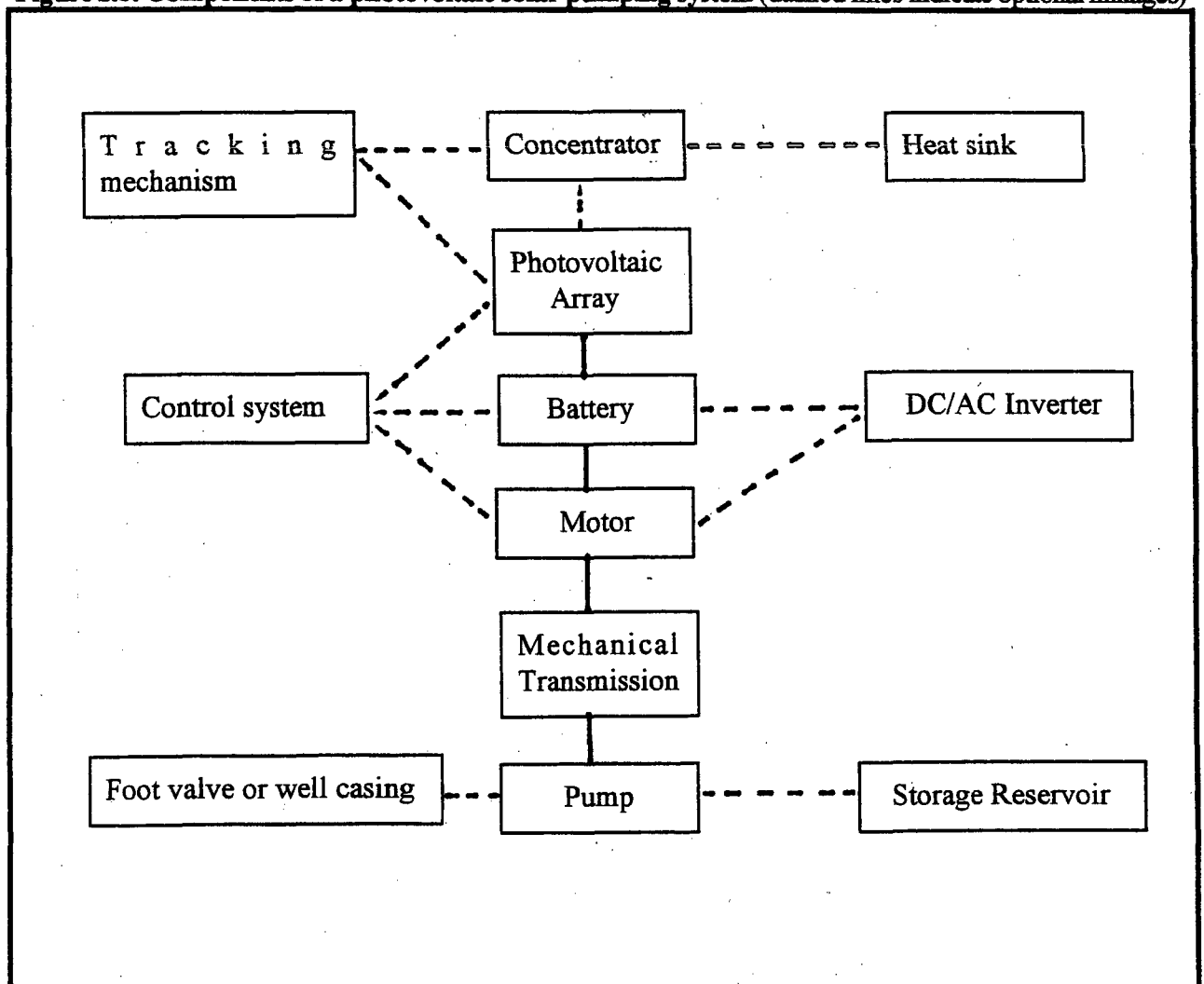

### 2.6.4 Mechanical Wind Pumps

Wind power has been used extensively for pumping water, and there are many thousands of wind pumps still in operation in South Africa. The typical farm wind pump consists of a multi-bladed fan-like rotor in which the rotating action is converted to a reciprocating action through a gearbox mounted directly behind the rotor. This reciprocating action is linked to a piston pump in a borehole directly below the windpump.

Windpumps are designed to run almost maintenance free, with maintenance required only once a year. These windpumps have automatic devices which prevent over-speeding of the rotor during storms. This requirement and their robustness makes them relatively expensive, but the costs are often considered well justified. However low maintenance does not mean maintenance free, and an annual check and greasing is required to ensure the ongoing smooth functioning of the pump, gearbox and rotor.

**Figure 2.9: Typical farm windpump**

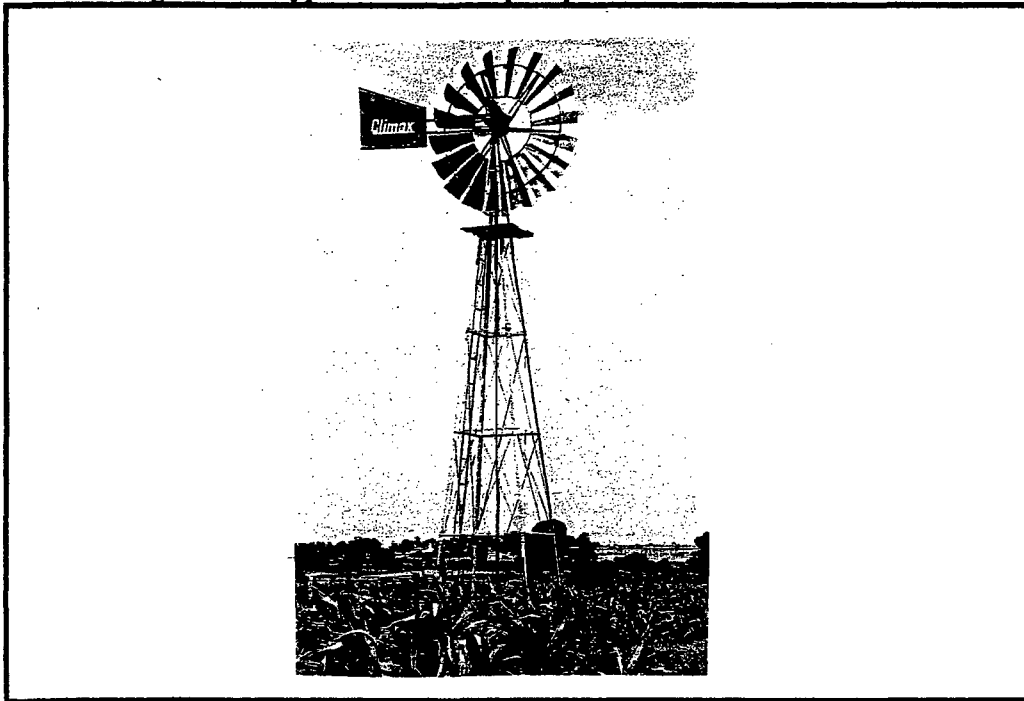

The power available from the wind is proportional to the wind speed cubed. This means that the power available for pumping is very sensitive to wind speeds. At low wind speeds very little power is available for pumping, while in stormy conditions it becomes essential to shed power or even shut the windpump down. The following table indicates the power available for a  $1\text{m}^2$  area of rotor at different wind speeds (Fraenkel 1986):

**Table 2.2: Wind power available from a  $1\text{m}^2$  rotor for different wind speeds**

wind speed	m/s	2.5	5	7.5	10	15	20	30	40
power	$\text{kW/m}^2$	0.01	0.08	0.27	0.64	2.2	5.1	17	41

The typical farm windpump design used widely in South Africa provide sufficient torque at low wind speeds to start the pump, while reducing rotor speeds at high wind speeds. The electric generator type of rotors, on the other hand, require very low wind speed for starting up.

An alternative windpump in South Africa makes use of an electric generator type of rotor connected directly to a small air pump. The air-pump is used to provide compressed air to operate an air-lift pump down a borehole. Since all the working parts are located above ground, this wind driven air-pump has significant advantages in terms of ease of maintenance. A number have been installed and are operating successfully.

### 2.6.5 Hand pumps

Hand pumps are used in many of the rural areas as the primary water supply for communities. Although the aims of development is to provide people with a higher level of service (e.g. tap stands supplied from a reservoir), there will always be a need for handpumps. The advantage of a hand pump is its low cost, and that each user contributes towards its operation by actually physically pumping of the water. Some designs of hand pumps are such that locally trained technicians can maintain them.

One of the main criteria, which determine the suitability of hand pumps for a particular application, is the energy requirement of the pumps. When considering the energy requirements it should be borne in mind that these pumps are specifically designed for human operation, and that one of the criteria for a good hand pump is the ease of operation for an "average person". Hence the theoretical mechanical efficiency of pumping is not the only aspect to be considered, but importantly also aspects relating to the ease of operation. For the long-term sustainability of hand and animal pumps, reliable operation without dependence on continual intervention by a central authority is also imperative. This means that the pumps should be designed so that community level maintenance can solve most of the expected breakdowns.

#### *Human power output*

A conservative estimate is that typical adult pump users can apply work at the rate of about 50 watts for extended pumping periods. Women may be slightly less than this (say 40 watts) and children say 30watts. Such extended periods will apply both to irrigation uses of handpumps and to pumping from substantial depths. For instance, to pump 20 litres from a depth of 45 metres will require about five minutes of continuous pumping if the user applies 50 watts of power and the pump has a mechanical efficiency of about 65%.

A more elaborate estimation of human power output for adults in favourable health in a tropical climate is given in Table 2.3 (Kennedy & Rogers 1985:3).



**Table 2.3 : Human power output under specified conditions**

Muscle group(s) involved	Sustained (up to 6-7 hrs) per day with short rests as and when req'd	10 to 15 mins	Few minutes
Mainly arms & shoulders	30W	50W	70W
All body (arms/shoulders, back, legs - non-peddalling)	40 to 50W	70W	100W
Peddalling	75W	180W	300W

Kennedy & Rogers further argue that for most water lifting tasks it can reasonably be assumed that the human power output range is in the order of 30W to 50W.

Considering an overall mechanical efficiency for the water lifting operation of 25 to 65% (the lower for some traditional methods and the upper for a good handpump), the power remaining for water lifting (in terms of "water watts") may be about 7W to 35W ("water watts" is the output power of the water actually lifted.)

The table below indicates the requirements of a range of commonly used handpumps, according to the depth of water to be pumped.

**Table 2.4 : Summary of pumping characteristics of various handpumps**

pump reference	head (m)	pumping rate		power requirements	
		strokes/min	ℓ/min	W	W/ℓ/min
New No.6	7	30	36	60	1.7
Rower	7	15	27	48	1.8
Maldev	7	41	19.7	38	1.9
Climax	7	60	19	64	3.4
India Mk II	7	40	12	47	3.9
Monolift	7	38	15	72	4.8
Moyno	7	40	9	45	5.0
Vergnet	7	92	24	199	8.3
Maldev	25	30	15.3	93	6.1
Climax	25	60	18.5	130	7.0
Moyno	25	40	8	59	7.4
India Mk II	25	40	12	92	7.7
Monolift	25	38	15	127	8.5

HANDBOOK ON PUMPS AND PUMPING SYSTEMS

pump reference	head (m)	pumping rate		power requirements	
		strokes/min	ℓ/min	W	W/ℓ/min
Maldev	45	45	21.6	205	9.5
Climax	45	60	18	183	10.2
India Mk II	45	40	12	140	11.7
Moyno	45	40	7	91	13.0
Monolift	45	38	12	165	13.8
Vergnet	45	75	14	245	17.5

- Notes: \*
- \* results from controlled tests and some field assessments;
  - \* the Maldev pump is also commonly called Afridev;
  - \* pumping efficiency is represented by the power requirement as W/ℓ/min;
  - \* other factors should also be considered - e.g. the Vergnet uses the whole body for pumping, while many of the other pumps use only arms and shoulders;
  - \* some of the pumps listed are not generally available in South Africa, but are promising options for consideration.

### 3. POWER REQUIREMENTS FOR PUMPS

In order to raise water by pumping, energy is required to drive the pump. The relationship between energy (a measure of the work done) and volume of water is given by the following formula:

$$E = \rho g V H \text{ (Joules)} \dots\dots\dots 1$$

- where E = the hydraulic energy in Joules
- V = the volume of water in m<sup>3</sup>
- H = the head in metres
- ρ = the density of water (1000 kg/m<sup>3</sup>)
- g = the gravitational acceleration (9,81 m/s<sup>2</sup>)

This formula can be expressed in kilowatt hours (kWh), which are the energy units commonly used in electrical definitions, thus:

$$E = \frac{9,81 V H}{3,6 \times 10^3} \text{ kW.h (where : } 3,6 \text{ MJ} = 1 \text{ kW.h)}$$

$$= \frac{V H}{367} \text{ kW.h} \dots\dots\dots 2$$

In order to select the right size of pump and motor it is important to know the power requirement (P). Power is defined as the rate of energy supplied, or the energy required per unit time. The formula relating power to the rate of flow of water (Q) is given by the following formula:

$$P = \rho g Q H \text{ Watt} \dots\dots\dots 3$$

- where P = the hydraulic power in Watt
- Q = the flow rate in m<sup>3</sup>/s
- H = the head in metres
- ρ = the density of water (1000 kg/m<sup>3</sup>)
- g = the gravitational acceleration (9,81 m/s<sup>2</sup>)

This formula can be expressed in kilowatt (kW) thus:

$$P = \frac{9,81 q H}{10^3} \text{ kilowatt, where } q = \text{flowrate in l/s}$$

$$P = \frac{q H}{10^2} \text{ kW} \dots\dots\dots 4$$

The above formula (4) is a particularly useful formula. It gives the theoretical hydraulic power requirement of a particular pumping site.

It must be realised that the above equations are still the theoretical power requirements. Because pumps and turbines are not 100% efficient, more power will be required to drive the pump in practice. The ratio between the theoretical amount and actual amount is a measure of the efficiency of the pump:

$$\text{actual power required} = \frac{P \times 100}{\text{efficiency \%}}$$

As an example, a pump is required to pump 50 l/s at a total head of 55 m, the hydraulic efficiency at this duty being 72 %.

The water kilowattage would be:

$$\frac{50 \times 55}{102} = 26.96 \text{ kW}$$

Therefore the actual power required for the pump is:

$$\frac{26.96 \times 100}{72} = 37.45 \text{ kW}$$

Each pump has its own performance characteristics, and hence its own optimum operating conditions. This is particularly true of centrifugal pumps. Therefore when a pump is specified for a certain operating condition, and is operated under different conditions, the efficiency can be expected to be reduced even further.

Other losses in efficiency arise when operating a diesel engine, which is used to drive a pump, at higher altitudes and or temperatures. Generally there is a 1 % reduction in power for every 2.8 °C above 29 °C, and there is a 3.5 % reduction in power per 300 m above 150 m above sea level. As a rough and useful guide, therefore, the power formula (4) above should be adjusted to give a power requirement estimate based on 50 % efficiency as follows:

$$P = \frac{qH}{50} \text{ kW}$$

## 4. IMPORTANT FACTORS AFFECTING THE CHOICE OF PUMPS

There are a number of factors which must be taken into consideration when selecting a pump for a certain application. It is advisable that all these be taken into account so that the longer term implications, and hence the sustainability of the pump system, are properly considered and planned for. It must also be emphasized that the users of the pump systems should be involved in making the choice where possible. This is a common principle of rural development, and applies particularly to items such as pumps which require continuous attention and maintenance.

### 4.1 Technical considerations

The technical suitability of a pump to a particular application is one of the most important considerations when selecting a pump. The advice of an experienced pump consultant or supplier should be sought when making a decision. A minimum of the following technical aspects should be taken into consideration:

- i) pump characteristics at the normal operating conditions;
- ii) pump characteristics at the possible range of conditions expected;
- iii) the matching of the pump with the other components of the pumping system, especially the suction and delivery pipelines and the engine;
- iv) the energy source and power required to operate the pump;
- v) the location of the pump site related to the availability of technical support and the transport of components, fuel and spares.

The relative importance of each of these depends on the site, the water supply system as a whole, and the technical and institutional capacity of the water supply authority responsible for operating and maintaining the installation.

### 4.2 Financial considerations

The costs assessment must consider both the capital cost and the ongoing operation and maintenance costs. The suppliers of the pumps will be able to provide information on operation and maintenance needs, but the assessment should consider at least the following:

- full capital costs including site preparation, civil works, transport and professional fees, purchase price, and installation and commissioning costs;
- monthly fuel or energy cost (determined from the power requirements);
- monthly line fees (for grid electricity);
- loss of efficiency due to wear and corrosion;
- salaries;
- administration costs;
- rental, transport, bank charges, etc.
- servicing and repairs;
- reserve for future replacements.

### 4.3 Scheduling of pumping hours

There can be considerable benefits to a water pumping system if proper scheduling of pumping hours is practised. Pumping hours may be scheduled for the following purposes:

- \* to maximize on periods when the electricity tariff is lowest;
- \* to effectively coincide pumping with demand periods and thereby minimize water shortages (usually due to inadequate storage capacity);
- \* to coincide with operators duty periods.

Note that these requirements may be conflicting, and pump hour scheduling may have to be comprised. The advantage of electrically driven pump systems, however, is that it is possible to automate parts of the pump operation to optimise possible benefits from pump hour scheduling.

### 4.4 Type of power source

The type of power or energy source used is a major consideration in the selection of pumping systems. Although it may be attractive to consider the use of renewable energy sources, the pros and cons of each source must be carefully considered. The following table indicates possible optimum conditions for the selection of a particular power source, but each situation should be considered on its own merits:

**Table 4.1 Conditions for use of various energy sources**

Energy source	pumping volume	level of skills		other
		maintenance	operation	
Grid electricity	unlimited	high	low	within 5 km of grid power lines
Fossil fuel (diesel)	unlimited	high	medium	access to and transport of diesel
Solar power	up to 100 000 R/d per installation	high	low	5 days maximum overcast or backup
Wind energy	up to 100 000 R/d per installation	high	low	only in eastern part of country
Human power	up to 10 000 R/d per installation	medium	low	maximum borehole water depth 45m

## 4.5 Operation and Maintenance needs

It is vital to plan for the ongoing operation and maintenance needs of each pumping system. This has been discussed in part under financial considerations (4.2), but must be further assessed when selecting a pumping system in terms of the following:

- \* skills and training requirements for operators and maintenance personnel;
- \* logistical needs in terms of spare parts, fuel storage and transport, reliability of energy source, and access to skilled service providers when required;
- \* administrative systems and support for accounts, tariff collections, store keeping, and financial management;
- \* tools and equipment needed for effective operation, maintenance and monitoring.

Once a pump and pumping system has been selected, it is a long term commitment which is made. It therefore cannot be overstressed that all the relevant factors related to each particular system is fully and openly assessed and discussed. The users of the system must be involved in the final selection.

## 5. OPERATION, MAINTENANCE AND MONITORING

The sustainability of any water supply scheme is ultimately dependent on the level of operation and maintenance which is practiced, and which itself is dependent on adequate financing and tariff collection. The focus of this section, however, will be restricted to operation, maintenance and monitoring of the actual pump installations.

Monitoring is not often linked as a task to operation and maintenance, but it should be considered as an important ongoing component of the every pump installation. Good monitoring acts as an early warning to any potential pump problems and could save a considerable amount of money in repair costs. Good monitoring also indicates changes in the entire water supply scheme, some of which may have an impact on the operation and maintenance of the pump installation.

### 5.1 Monitoring of pump performance

The methodology for monitoring and evaluation of pumping system performance basically consists of four steps.

- i) Through data collection at the start of the tests the technical system and its environment is described. A technician should carry this out. Appendix B gives examples of data sheets for different pumping systems.
- ii) During the short term testing phase technical data are gathered over a period of only a few days. It is preferred that these tests are also carried out by skilled technicians, who will also be able to do the subsequent data reduction and analysis in this phase. The procedures set out in appendix C may be followed.

- iii) During long term testing relatively little work has to be done, be it over a much longer period of time. The information required strongly relates to the experiences of the owner or operator of the system (costs, reliability, need for maintenance, etc.) rather than to "pure technology". Routine tests are executed while the pumping system is being used and water is supplied to its specific end use.
- iv) At intervals to carry out specific evaluation of the pumping system, in which a more detailed assessment of the system is undertaken. Again a technician should be used for this task.

The owner/operator will be the major resource person during long term testing. He takes daily care of the pumping system and he will be asked to keep a regular logbook of all relevant data. The owner/operator needs to be properly motivated to perform this task and some training might be required to ensure proper logbook keeping. This is an important issue, because an owner/operator will often not be convinced of the need and usefulness of the data to be collected or of the accuracy required.

#### **5.1.1 Short Term Testing**

The aim of short term testing is to accurately determine the characteristics of the pumping system at the time of installation and commissioning. This enables any immediate performance discrepancies to be discovered and corrected, as well as accurately classifying the actual characteristics of the system. All future measurements should be made using this set of tests as a basis for comparison. The operators should participate in these tests to familiarise them with the system and to enable them to take over the longer term testing programme with confidence.

The inspection schedules and data recording sheets for short term testing are contained in appendix C.

#### **5.1.2 Long Term Monitoring**

Longer term monitoring is useful for noticing gradual and sudden changes in the system and in the performance of the pumps. This level of monitoring should be carried out by the pump operators and the respective water supply authority.

Typical monitoring forms for each type of pumping system are given in appendix A.

An important aspect of longer term monitoring is the regular inspection and interpretation of the monitoring data. The operators and water supply authorities should be trained to properly assess and interpret the data.

#### **5.1.3 Periodic System Evaluations**

Periodic detailed system evaluations may be required at times of system problems, or after a major repair has been carried out. This evaluation will be similar to the short term testing as in 5.1.1.



## **5.2 Operation and maintenance requirements**

Each pumping system and in fact each individual installation is unique and requires specific operation and maintenance procedures. Each pump installation should receive operation and maintenance instructions and, if necessary, training of the operators. It is not possible or necessary to deal with this aspect to any depth in this manual. The main focus of the operation and maintenance programme is to ensure that daily, weekly and monthly tasks are properly carried out, and that the operators take responsibility for proper monitoring and recording of system performance and of actions taken to address system faults.

An additional aspect that should receive mention is the education of community members in the use and care of the pumping system components. This is particularly relevant for hand pump installations where direct contact of the consumers with the pump may be made on a daily basis.

Each installation should be provided with a Operation and Maintenance Manual for that specific installation.

## 6. REFERENCES

- Arlosoroff, S. et al. 1984. Rural water supply handpumps project. Handpumps testing and development: Progress report on field and laboratory testing. Washington, DC: World Bank.
- Arlosoroff, S. et al. 1987. Community water supply. The handpump option. Washington, DC: World Bank.
- Fraenkel, P. 1986. Water—pumping devices. Intermediate Technology Publications, London, 171p.
- Hofkes, E.H. (ed.) 1981. Small community water supplies. Technology of small water supply systems in developing countries. The Hague: IRC.
- IDRC. 1987. IDRC Handpump Network. Proceedings of the meeting held in Bangkok, Thailand, 1-3 October, 1986.
- IRC 1983. Hand Pumps for use in drinking water supplies in development countries. Technical Paper No 10, International Reference Centre, Rijswijk, The Netherlands. 227p.
- Kennedy, W.K. & Rogers, T.A. 1985. Human and animal-powered water-lifting devices. London: Intermediate Technology Publications.
- O Hea, A. 1983. Performance index for man—powered pumps. "Appropriate Technology" Vol.9, no.4. p.10—11.
- Omar, I and Law, S.M. 1991. Energy alternatives for the supply of water in Namaqualand. Energy Research Institute, UCT, Cape Town. Draft final report to the National Energy Council, Report No. Int 162. 124p.
- Oostendorp, P.A. and Booth, D. (Eds) 1988. Handbook for comparative evaluation of technical and economic performance of water pumping systems. Consultancy Services Wind Energy Developing Countries, Amersfoort, Holland.
- Pacey, A. 1977. Hand-pump maintenance. Intermediate Technology Publications, London, 43p.
- Wiseman, K. and Eberhard, A.A. 1987. A technical, social and economic assessment of water lifting technologies for rural water supply in underdeveloped areas of Southern Africa. Energy Research Institute, UCT, Cape Town. Final Report to the Foundation for Research Development. 219p.
- Yau, Goh Sing. 1985. Laboratory and field testing of handpumps. Ottawa: International Development Research Centre, Canada.

## APPENDIX A

### COST ANALYSIS AND PERFORMANCE REPORTING FOR PUMP SYSTEMS

The following data analysis sheets may be helpful in costing pump installations. These data analysis sheets are set out for an electric pump installation as an example, but may be modified for use with any pump system. Data for the reports will need to be assessed as described in appendix C.

**COST ANALYSIS SHEET 1:**                      System description - Grid Connected Electric Pump  
(to be completed by technician)

<b><u>INITIAL INVESTMENTS</u></b>				
ITEM	(a) Purchase Cost OR: off-works	(b) Handling, storage, transport, etc.	(c) Installation	(a+b+c)  TOTAL
Pump				
Motor and starter				
Piping, valves and meters				
Connection to electricity grid				
Electric controls				
Pumphouse and works				
Storage tank				
Other				
Installation / site preparation:				
* skilled labour				
* unskilled labour				
* transport				
<b>TOTAL INSTALLED COST</b>				

PUMP PERFORMANCE REPORT

Summary for Electric Pumping System

(to be completed by technician)

SUMMARY OVER 20 _____				
Location	:			
District	:			
Owner	:			
<b>Performance</b>				
Yearly electric energy consumption	:			[kWh]
Yearly water volume pumped	:			[m <sup>3</sup> ]
Overall system efficiency	:			[-]
<b>Operation</b>				
Operating time of the system	:			[hours]
Total time needed for maintenance	:			[hours]
Total time needed for repairs	:			[hours]
Total down-time	:			[hours]
Number of break-downs	:			[-]
Mean down time	:			[hours]
Mean time between failures	:			[hours]
Availability	:			[-]
Other uses of system	:			[hours]
(pls. Give details in log or below	:			
<b>Recurrent Costs</b> [ _____ ] *				
	operation	maintenance	repair	total
Skilled labour				
Unskilled labour				
Electricity				
Materials				
Parts				
Transportation				
Replacements				
*) Note details on replacements (types and time), repairs, etc. in the log.				

## **APPENDIX B**

### **DATA SHEETS FOR PUMP SYSTEMS (after Oostendorp & Booth 1988)**

The following data sheets will be helpful in ensuring that all the necessary information on the pump installations is available for future maintenance, evaluations, and/or equipment replacements.

**DATA SHEET**

**System description: Grid Connected Electric Pump**  
(to be completed by technician).

<p><b><u>Electric Grid</u></b>                  Extent of the grid : Local/ regional ____*                  Voltage and variation : ____ [Volt], +/- ____ [Volt]                  Frequency and variation : ____ [Hz], +/- ____ [Hz]</p>	
<p><b><u>Electric motor</u></b>                  Year of manufacture : ____                  Make, type : ____                  Nominal shaft power : ____ [kW]                  Voltage : ____ [Volt, single/three phase*]                  Nominal rotational speed: ____ [revs/min]                  Rated power : ____ [kW] / [kVA] *                  Power factor (cos Ø) : ____ [-]</p>	<p><b>Manufacturer</b>                  Name : ____                  Address : ____                  Serial no: ____</p>
<p><b><u>Transmission</u></b>                  Type : ____                  Transmission : ____ [motor revs / pump rev]</p>	<p><b>Manufacturer</b>                  Name : ____                  Address: ____</p>
<p><b><u>Pump</u></b>                  Year of manufacture : ____                  Make : ____                  Type : Centrifugal / Mono / ____*                  Position : ____ [meters below ground level]                  Nominal rotational speed: ____ [rev min]                  Nominal capacity : ____ [kW]                  Nominal efficiency: ____ % at ____ [revs/min]</p>	<p><b>Manufacturer</b>                  Name : ____                  Address: ____                  Serial no: ____</p>
<p><b><u>Storage tank</u></b> (if any)                  Year of manufacture : ____                  Type, structure : ____                  Length, Width, Height : ..... * ..... * ..... = ..... [m<sup>3</sup>]                  or: Diameter, Height : 0.7854 * (.....)<sup>2</sup> * ..... = ..... [m<sup>3</sup>]                  or: Capacity : ____ [m<sup>3</sup>]                  Minimum water level : ____ [meters above ground level]</p>	<p><b>Manufacturer</b>                  Name : ____                  Address: ____                  Serial no: ____</p>
<p><b><u>Back-up system</u></b> (if any)                  Year of manufacture : ____                  Make, type : ____                  Capacity : ____</p>	<p><b>Manufacturer</b>                  Name : ____                  Address: ____                  Serial no: ____</p>
<p>*) Circle the correct answer</p>	

**DATA SHEET**

**System description: Fuel Engine Pumps**  
( to be completed by technician)

<p><b><u>I C Engine</u></b>                      Year of manufacture : _____                      Make, type : _____                      Nominal shaft power : _____ [kW]                      Nominal rotational speed: _____ [revs / min]                      Nominal fuel consumption: _____ [ l/h]                      Type of fuel : diesel / petrol / kerosene _____ *)                      Volume of fuel tank : _____ [l]</p>	<p><b>Manufacturer</b>                      Name : _____                      Address : _____                      Serial no: _____</p>
<p><b><u>Transmission</u></b>                      Type : _____                      Transmission : _____ [motor revs / pump rev]</p>	<p><b>Manufacturer</b>                      Name : _____                      Address: _____</p>
<p><b><u>Pump</u></b>                      Year of manufacture : _____                      Make : _____                      Type : Centrifugal / Mono / _____ *                      Position : _____ [meters below ground level]                      Nominal rotational speed: _____ [rev min]                      Nominal capacity : _____ [kW]                      Nominal efficiency : _____ % at _____ [revs/min]</p>	<p><b>Manufacturer</b>                      Name : _____                      Address: _____                      Serial no: _____</p>
<p><b><u>Storage tank (if any)</u></b>                      Year of manufacture : _____                      Type, structure : _____                      Length, Width, Height : ..... * ..... * ..... = ..... [m<sup>3</sup>]                      or: Diameter, Height : 0.7854 * ( ..... )<sup>2</sup> * ..... = ..... [m<sup>3</sup>]                      or: Capacity : _____ [m<sup>3</sup>]                      Minimum water level : _____ [meters above ground level]</p>	<p><b>Manufacturer</b>                      Name : _____                      Address: _____                      Serial no: _____</p>
<p><b><u>Back-up system (if any)</u></b>                      Year of manufacture : _____                      Make, type : _____                      Capacity : _____</p>	<p><b>Manufacturer</b>                      Name : _____                      Address: _____                      Serial no: _____</p>
<p>*) Circle the correct answer</p>	

**DATA SHEET**

**System description: Solar Pump (to be completed by technician)**

<p><b><u>Solar array</u></b>                      Year of manufacture : _____                      Make, type : _____                      Effective area : _____ [m<sup>2</sup>]                      Orientation : _____                      Rated power : _____ [W] at irradiance _____ [W/m<sup>2</sup>]                      Rated voltage : _____ [Volt] at irradi. _____ [W/m<sup>2</sup>]</p>	<p><b>Manufacturer</b>                      Name : _____                      Address: _____                      Serial no: _____</p>
<p><b><u>Power control system</u></b>                      Make, type : _____                      Battery storage (if any) : _____ [kWh]</p>	<p><b>Manufacturer</b>                      Name : _____                      Address: _____</p>
<p><b><u>Electric pump</u></b>                      Year of manufacture : _____                      Make : _____                      Type : _____                      Position : _____ [meters below ground level]                      Nominal rotational speed: _____ [rev / min]                      Nominal capacity : _____ [kW]                      Voltage : _____ [Volt] AC/DC*</p>	<p><b>Manufacturer</b>                      Name : _____                      Address: _____                      Serial no: _____</p>
<p><b><u>Storage tank (if any)</u></b>                      Year of manufacture : _____                      Type, structure : _____                      Length, Width, Height : ..... * ..... * ..... =                      ..... [m<sup>3</sup>]                      or: Diameter, Height : 0.7854 * ( ..... )<sup>2</sup> * ..... = .....                      [m<sup>3</sup>]                      or: Capacity : _____ [m<sup>3</sup>]                      Minimum water level : _____ [meters above ground level]</p>	<p><b>Manufacturer</b>                      Name : _____                      Address: _____                      Serial no: _____</p>
<p><b><u>Back-up system (if any)</u></b>                      Year of manufacture : _____                      Make, type : _____                      Capacity : _____</p>	<p><b>Manufacturer</b>                      Name : _____                      Address: _____                      Serial no: _____</p>
<p>* ) Circle the correct answer</p>	





**DATA SHEET**

**System description: handpump (to be completed by technician)**

<p><b><u>Hand pump</u></b></p> <p>Year of manufacture : _____</p> <p>Make : _____</p> <p>Type : Piston / Centrifugal / Mono / _____ *</p> <p>Position : _____ [meters below ground level]</p> <p>(Only for piston pumps)</p> <p>Pump diameter : _____ [mm]</p> <p>Maximum pump stroke : _____ [mm]</p> <p>(Only for screw pumps)</p> <p>Nominal flow rate : _____ [l / min] at _____ [revs / min]</p> <p>(Other pumps) **</p> <p>Nominal flow rate : _____ [l / min]</p> <p>Nominal condition : _____</p> <p>Capacity of bucket : _____ [l]</p> <p>Numbers of buckets : _____ [-]</p> <p>_____ : _____</p> <p>_____ : _____</p>	<p><b>Manufacturer</b></p> <p>Name : _____</p> <p>Address: _____</p> <p>Serial no: _____</p>
<p><b><u>Storage tank (if any)</u></b></p> <p>Year of manufacture : _____</p> <p>Type, structure : _____</p> <p>Length, Width, Height : ..... * ..... * ..... = .....[m<sup>3</sup>]</p> <p>or: Diameter, Height : 0.7854 * ( ..... )<sup>2</sup> * ..... = ..... [m<sup>3</sup>]</p> <p>or: Capacity : _____ [m<sup>3</sup>]</p> <p>Minimum water level : _____ [meters above ground level]</p>	<p><b>Manufacturer</b></p> <p>Name : _____</p> <p>Address: _____</p> <p>Serial no: _____</p>
<p>* ) Circle the correct answer</p>	

## APPENDIX C

### DATA SHEETS FOR PERFORMANCE MONITORING OF PUMP SYSTEMS

(after Oostendorp & Booth 1988)

The following data sheets will be helpful in monitoring the performance of the pump installations and their maintenance records.

#### C1 GRID-CONNECTED ELECTRIC PUMPS

This section covers water pumping systems in which the prime mover is an electric motor. The motor is coupled mechanically, generally through a transmission, to the pump, which may be a rotating screw (Mono) or centrifugal type. A local or regional electric grid supplies the power for the motor.

#### PUMP INSPECTION

The following inspections should be carried out. The results should be included as comments in narrative form in the logbook, with notations as to which component or part was inspected and the results of the inspection. If a component listed below is not inspected, that fact should be noted.

Visually inspect the electric motor, electric power cables, meters, cable junctions and splices, and control switches. Comment on the condition of the insulation and electrical contracts, looking particularly for evidence of overheating, arcing at contracts, bare wires, frayed insulation and exposed junctions. Note condition of lubrication of motor bearings, transmission or pump.

Listen to the pump during normal operation. Note if the system does not appear to be in satisfactory physical condition (e.g., look for excessive corrosion, lack of lubrication, lubricant leaks, worn seals) or if the system performance during operation appears to be clearly unsatisfactory (e.g., very low water flow rate, excessive leaks, excessive pump vibrations or noise etc.).

Inspect system piping and valves visually. Open and close all valves (not during operation of the pump !). Note valves which do not operate. Note on a sketch the location and severity of leaks in valves and piping, if any. Also where possible, note the physical condition of the interior surfaces of piping and valves. Determine whether a build-up of scale or other deposits has formed that reduces the effective diameter of the pipe or that causes the interior surface to be extremely rough. Note where the wall thickness has been reduced significantly by corrosion.

Note: Following inspection of the valves, it should be determined that all of the valves leading to and from the pump are set in their open position prior to beginning the tests.

Inspect the water intake. Examine screens if they are accessible and note their condition, i.e., whether they are intact or have visible holes, whether they are clogged, etc.

For bore hole wells, measure the static suction head (vertical distance from the water level in the borehole to the pump inlet when no water is being pumped and the pump has been off for at least two hours).

### SET OF TIME MEASUREMENTS:

The following constitutes a set of measurements:

#### Time

Record the time  $t$  (hour, minute, second) of the beginning and end of each time measurement period.

#### Electric energy

Record the readings (kWh) of the integrating power meter  $E_{el}$  at the beginning and the end of each time measuring period.

#### Water volume pumped

Record the readings (cubic meters) of the integrating flowmeter ( $Q$ ) at the beginning and at the end of each time measuring period.

#### Suction head

Record the suction head reading ( $H_s$  in meters) of the measuring stick, well dipper or other suction head measuring equipment once during each period.

Note: The suction head can be negative because the pump is below the water surface in the well.

#### Discharge head

Record the reading (meters) of the pressure gauge at the pump discharge  $H_{dis}$  once during time period.

Note: Not all pressure gauges read in meters. Other possibilities are bar, At (atmosphere), psi (pound per square inch) and kPa (kiloPascal). The following conversion factors should be used:

Pressure	equivalent head	
1 bar	10	[m]
1 at	10	[m]
1 psi	0.69	[m]
1 kPa	0.1	[m]

### Pump Speed (optional)

If a variable speed transmission is used and measurements are made at different speeds, then measure the pump speed  $n_s$  (rpm) using a tachometer at the beginning of each time period.

### **CALCULATIONS**

#### Average electric power input

Calculate the average power input for each time period:

$$P_{el,T} = \frac{3600 * (E_{el,e} - E_{el,b})}{T} \quad [kW]$$

where:

- $E_{el,b}$  = the electric energy meter reading [kWh] at the beginning of period T
- $E_{el,e}$  = the electric energy meter reading [kWh] at the end of period T
- T = the length of the measuring period [s]
- 3600 = conversion factor (seconds per hour)

Example: At 09:41:05 the energy meter reading was 345.648 kWh.  
At 09:51:10 the energy meter reading was 345.730 kWh.  
Because the length of the measuring period was 605 s, the average power input according to the formula is:

$$P_{el,T} = \frac{3600 * (345.730 - 345.648)}{605} = 0.488 [kW]$$

#### Average water flow rate

Calculate the average water flow rate for each time period:

$$q_{pT} = \frac{1000 * (Q_{p,e} - Q_{p,b})}{T} \quad [l/s]$$

where:

- $Q_{p,b}$  = the integrating flowmeter reading [cubic meters] at the beginning of each ten minute period.
- $Q_{p,e}$  = the integrating flowmeter reading at the end of each ten minute period.
- T = the length of the measuring period [s]
- 1000 = conversion factor (litres per cubic meter)

Example: If  $Q_{p,b} = 723.19 [m^3]$  and  $Q_{p,e} = 724.42 [m^3]$ , then the average flow rate is  $q_{pT} = 2.07 [l/s]$

### Total effective head

Calculate the total effective head H for each time period:

$$H = H_{in} + H_{dis} \quad [m]$$

where:

$$\begin{aligned} H_{in} &= \text{suction head [m]} \\ H_{dis} &= \text{discharge head [m]} \end{aligned}$$

Example: During a time period the suction and discharge head were -2.4 m and 10.4 m, respectively. As a result the total effective head is 8.0 m.

### Hydraulic power output

Calculate the hydraulic power output for each time period:

$$P_{h,T} = \frac{9.81 * q_{PT} * H}{1000} \quad [kW]$$

where:

$$\begin{aligned} q_{PT} &= \text{the average water flow rate in [l/s]} \\ H &= \text{the total effective head (m)} \\ 9.81 &= \text{the acceleration due to gravity} \\ 1000 &= \text{conversion factor (litres per cubic meter)} \end{aligned}$$

Example: For the time period in the previous example  $q_{PT} = 2.25$  [l/s]. Then hydraulic power output is:

$$P_{h,T} = \frac{9.81 * 2.25 * 8.0}{1000} = 0.177 \text{ kW}$$

### System Efficiency

For each of the time measurement sets, calculate the overall system efficiency  $n_{tot}$  using the following equation:

$$n_{tot} = \frac{P_{h,t}}{P_{el,T}} \quad [-]$$

where:

$$\begin{aligned} P_{h,T} &= \text{Hydraulic power output and} \\ P_{el,T} &= \text{Average electric power input, both as calculated above.} \end{aligned}$$

## **C2 FUEL ENGINE PUMP SYSTEMS**

This section covers water pumping systems in which the prime mover is a fuel engine pump. The fuel engine may be either a compression ignition (diesel) or spark ignition (gasoline) engine. The engine is coupled mechanically, generally through a transmission, to the pump, which may be a rotating screw (Mono) or centrifugal type.

### **Pump inspection**

The following inspections should be carried out. The results should be included as comments in narrative form in the logbook, with notations as to which component or part was inspected and the results of the inspection. If a component listed below is not inspected, that fact should be noted. However, unless the system is not in operating order, do not carry out any maintenance at this time based on the pre-test inspections.

Visually inspect the engine block, fuel storage tank and fuel lines, fan and fan belt, coolant water reservoir and radiator, internal engine lubricating oil reservoir, and associated gauges and instruments. Comment on the overall condition of the engine, particularly observing the adequacy of engine internal and external lubricating oil and grease, the presence of oil or water leaks, and the presence of dirt or other solid particulates in the cooling water, lubricating oil or grease. Comment on the condition of the spark plugs and / or carburettor or fuel injectors, fan and fan belt and radiator fins.

Listen to and inspect the engine during normal operation. Note difficulties in starting the engine from a cold or from a hot condition. Comment on the observed vibration of the engine block, fuel reservoir and piping, and other associated equipment. Note abnormal noises from the fan and fan belt.

Listen to and inspect the pump during normal operation. Note if the system does not appear to be in satisfactory physical condition (e.g., look for excessive corrosion, lack of lubrication, lubricant leaks, worn seals) or if the system performance during operation appears to be clearly unsatisfactory (e.g., very low water flow rate, excessive leaks, excessive pump vibrations or noise etc.).

Inspect system piping and valves visually. Open and close all valves (not during operation of the pump ! ). Note valves which do not operate. Note on a sketch the location and severity of leaks in valves and piping, if any. Also where possible, note the physical condition of the interior surfaces of piping and valves. Determine whether a build-up of scale or other deposits has formed that reduces the effective diameter of the pipe or that causes the interior surface to be extremely rough. Note where the wall thickness has been reduced significantly by corrosion.

Note: Following inspection of the valves, it should be determined that all of the valves leading to and from the pump are in their open position prior to the beginning of the tests.

Inspect the storage tank if included in the system. Note any leaks. Clean the sight glass if present.

Inspect the water intake. Examine screens if they are accessible and note their condition, i.e., whether they are intact or have visible holes, whether they are clogged, etc.

For borehole wells, measure the static suction head (vertical distance from the water level in the borehole to the pump inlet when no water is being pumped and the pump has been off for at least two hours).

### Pumping performance

The pumping performance tests will consist of sets of measurements taken during ten minute time intervals. The tests will be run at different pump speeds if possible. It is recommended to take the sets of measurements as a continuous series. The measurements then just reduce to recording every 10 minutes the readings of the various instruments. Accuracy will greatly improve when the integrating instruments (time, fuel consumption and flow) are read in the same order every time.

### Fuel consumption

Calculate the fuel consumption for each time period:

$$V_{\text{fuel}} = C_{\text{fuel,e}} - C_{\text{fuel,b}} \quad [\text{cm}^3]$$

where:

- $C_{\text{fuel,b}}$  = fuel measuring cylinder reading at the beginning of period T
- $C_{\text{fuel,e}}$  = fuel measuring cylinder reading at the end of period T

If alternatively the fuel consumption is measured by recording the amount of fuel to be added at the end of period T to fill the fuel tank to the mark as described above,  $V_{\text{fuel}}$  simply equals this amount

Example: At 09:11:14 the level in the fuel cylinder was, 475.2 cm<sup>3</sup>. At 09:21:33 the level was 530.3 cm<sup>3</sup>.  $V_{\text{fuel}}$  equals the difference between these numbers:

$$V_{\text{fuel}} = 530.5 - 475.2 = 55.3 \text{ cm}^3$$

### Average water flow rate

Calculate the average water flow rate for each ten minute period:

$$q_{\text{PT}} = \frac{1000 * (Q_{\text{p,e}} - Q_{\text{p,b}})}{T} \quad [\text{ls}]$$

Where:

- $Q_{\text{p,b}}$  = the integrating flowmeter reading [cubic meters] at the beginning of each ten minute period.
- $Q_{\text{p,e}}$  = the integrating flowmeter reading at the end of each minute period.
- T = the length of the measuring period [s]
- 1000 = conversion factor (litres per cubic meter)



Example: If  $Q_{P,b} = 727.43 \text{ [m}^3\text{]}$  and  $Q_{P,e} = 731.32 \text{ [m}^3\text{]}$ , then the average flow rate is  
 $q_{PT} = 6.7 \text{ [l/s]}$

### Total effective head

Calculate the total effective head H for each ten minute period:

$$H = H_{in} + H_{dis} \text{ [m]}$$

where:  $H_{in}$  = suction head [m]  
 $H_{dis}$  = discharge head [m]

Example: From 09:31:24 to 09:41:05 the fuel consumption  $V_{fuel} = 60.2 \text{ cm}^3$ . Assuming for the example that the fuel is diesel oil gives  $B = 11 \text{ kWh/l}$ . Then the fossil power input is:

$$P_{fossil} = \frac{3.6 * 60.2 * 11}{581} = 4.1 \text{ kW}$$

### Hydraulic power output

Calculate the hydraulic power output for each 10 minute period:

$$P_{h,T} = \frac{9.81 * q_{PT} * H}{1000} \text{ [kW]}$$

where:  $q_{PT}$  = the average water flow rate in [l/s]  
 $H$  = the total effective head (m)  
 $9.81$  = the acceleration due to gravity  
 $1000$  = conversion factor (litres per cubic meter)

Example: For the ten minute period in the previous example  $q_{PT} = 6.7 \text{ [l/s]}$ . Then the hydraulic power output is:

$$P_{h,T} = \frac{9.81 * 6.7 * 8.1}{1000} = 0.53 \text{ kW}$$

### System Efficiency

For each of the 10 minute measurements sets, calculate the overall system efficiency  $n_{tot}$  using the following equation:

$$n_{tot} = \frac{P_{h,T}}{P_{fossil}} \text{ [-]}$$

### C3 SOLAR

This section covers water pumping systems in which the prime mover is a solar photovoltaic electric pump. The systems may use AC or DC motors which drive centrifugal or screw type pumps. The systems may make use of power conditioning equipment to adjust the voltage level generated under various irradiance conditions in order to result in higher pump and motor efficiencies.

#### PUMP INSPECTION

The following inspections should be carried out. The results should be included as comments in narrative form in the logbook, with notations as to which component or part was inspected and the results of the inspection. If a component listed below is not inspected, that fact should be noted. However, unless the system is not in operating order, do not carry out any maintenance at this time based on the pretest inspections.

Visually inspect the array assembly. Note in the logbook the relative cleanliness (transparency) of the array glass covers, and the number and location of modules or cells that are known to be defective. Examine the instruments and controllers and note in the logbook signs of insulation deterioration or moisture intrusion which may cause shorting.

Listen to and inspect the pump during normal operation. Note if the system does not appear to be in satisfactory physical condition (e.g., look for excessive corrosion, lack of lubrication, lubricant leaks, worn seals) or if the system performance during operation appears to be clearly unsatisfactory (e.g., very low water flow rate, excessive leaks, excessive pump vibrations or noise etc.).

Inspect system piping and valves visually. Open and close all valves (not during the operation of the pump!). Note valves which do not operate. Note on a sketch the location and severity of leaks in valves and piping, if any. Also where possible, note the physical condition of the interior surfaces of piping and valves. Determine whether a buildup of scale or other deposits has formed that reduces the effective diameter of the pipe or that causes the interior surface to be extremely rough. Note where the wall thickness has been reduced significantly by corrosion.

Note: Following inspection of the valves, it should be determined that all of the valves leading to and from the pump are in their open position prior to the beginning of the tests.

Inspect the storage tank if included in the system. Note any leaks. Clean the sight glass if present.

Inspect the water intake. Examine screens if they are accessible and note their condition, i.e., whether they are intact or have visible holes, whether they are clogged, etc.

For bore hole wells, measure the static suction head (vertical distance from the water level in the borehole to the pump inlet when no water is being pumped and the pump has been off for at least two hours).

## Pumping Performance

The pumping performance tests will consist of sets of measurements taken during time intervals under conditions where the solar panels are receiving full sun.

The measurement intervals should be distributed equally throughout the day starting at approximately 9:00 local time and ending at approximately 16:00 local time. A total of 50 sets of say ten minute measurements should be taken over a period of several days.

It is recommended to take the sets of measurements in a number of blocks of consecutive measurements. Within these blocks the measurements then just reduce to recording every 10 minutes the readings of the various instruments. Accuracy will greatly improve when the integrating instruments (time, irradiation, array energy output, flow and stroke / revolution counter) are read in the same order every time.

### Average solar irradiance

Calculate the average irradiance  $P_{sol,T}$  for each ten minute period:

$$P_{sol,T} = \frac{3600 * (E_{sol,e} - E_{sol,b})}{T} \quad [W/m^2]$$

where:

$E_{sol,b}$	=	the integrating pyranometer reading at the beginning of period T (Wh/m <sup>2</sup> ).
$E_{sol,e}$	=	the integrating pyranometer reading at the end of period T.
T	=	length of measuring period T (s).
3600	=	conversion factor (seconds per hour)

Example: If  $E_{sol,b} = 8660$  [Wh/m<sup>2</sup>] and  $E_{sol,e} = 8825$  [Wh/m<sup>2</sup>], the average solar irradiance is:

$$P_{sol} = \frac{3600 * (8825 - 8660)}{597} = 995 \text{ W/m}^2$$

### **Discharge head effect (optional)**

The following day or the next clear day, close a discharge valve such that the discharge flow rate is reduced by about 25-50%. Start the motor and pump as in the preceding paragraph and repeat the measurements.

### Power Input

Calculate the average solar power input  $P_{sol,i}$  for each ten minute period using the following equation:

$$P_{sol,i} = P_{sol,T} * A_{array} \quad [W]$$

where:

$$\begin{aligned} P_{sol,T} &= \text{the average irradiance (W/m}^2\text{)} \\ A_{array} &= \text{the gross solar surface area (m}^2\text{)} \end{aligned}$$

Example: Between 14:21:38 and 14:31:41 the average solar power input was:

$$P_{sol,i} = 901 * 3.4 = 3063.4 \quad [W]$$

### Hydraulic power output

For each of the ten minute measurements sets, calculate the hydraulic power output  $P_{h,T}$  using the following equation:

$$P_{h,T} = 9.81 * q_{PT} * H \quad [\text{watt}]$$

where:

$$\begin{aligned} q_{PT} &= \text{the average flow rate (l/s)} \\ H &= \text{the total effective head (m)} \\ 9.81 &= \text{the acceleration due to gravity} \end{aligned}$$

Example: If  $q_{PT} = 0.96$  [l/s] and  $H_{in}$  and  $H_{dis}$  are 3.8 [m] and 7.8 [m] respectively, then  $P_{h,T} = 109.2$  [watt].

### Overall system efficiency

For each of the 10 minute measurement sets, calculate the overall system efficiency  $\eta_{tot}$  using the following equation:

$$\eta_{tot} = \frac{P_{h,T}}{P_{sol,i}} \quad [-]$$

## C4 MECHANICAL WIND PUMPS

This section covers water pumping systems in which the prime mover is a windmill. The windmill is coupled mechanically, generally through a transmission, to the pump, which may be a reciprocating, rotating screw (Mono), or centrifugal type.

### PUMP INSPECTION

The following inspections should be carried out. The results should be included as comments in narrative form in the logbook, with notations as to which component or part was inspected and the results of the inspection. If a component listed below is not inspected, that fact should be noted. However, unless the system is not in operating order, do not carry out any maintenance at this time based on the pre-test inspections.

Inspect the windmill rotor, the transmission and the pump assembly visually. Determine the condition of the blades, shaft and bearings, both those used for transmitting power and for yawing. Note changes from the original form or spacing of the blades. Comment on the visible wear of all the moving parts including bearings and transmission gears. Note whether lubrication appears adequate.

Observe the windmill during operation. Note whether the rotor turns freely in its bearings and whether it turns easily with the changes in the wind direction. Note excessive vibration of windmill shaft or transmission, if any, while the rotor is rotating.

Listen to the pump during operation. Note if the system does not appear to be in satisfactory physical condition (e.g. look for excessive corrosion, lack of lubrication, lubricant leaks, worn seals) or if the system performance during operation appears to be clearly unsatisfactory (e.g. very low water flow rate, excessive leaks, excessive pump vibrations, noises).

Inspect system piping and valves visually. With the windpump furled, open and close all valves. Note valves which do not operate. Note on a sketch the location and severity of leaks in valves and piping, if any. Also where possible, note the physical condition of the interior surfaces of piping and valves. Determine whether a build-up of scale or other deposits has formed that reduces the effective diameter of the pipe or that causes the interior surface to be extremely rough. Note where the wall thickness has been reduced significantly by corrosion.

#### Note:

Following inspection of the valves, it should be determined that all of the valves leading to and from the pump are set in their open position prior to beginning the tests.

Inspect the storage tank if included in the system. Note any leak. Clean the sight glass if present.

Inspect the water intake. Examine screens if they are accessible and note their condition, i.e. whether they are intact or have visible holes, whether they are clogged, etc.

For borehole wells, measure the static suction head (vertical distance from the water level in the borehole to the pump inlet when no water is being pumped and the pump has been off for at least two hours).

### Average windspeed

Calculate the average windspeed for each time period:

$$V_T = \frac{1000 * (R_{w,e} - R_{w,b})}{T} \quad \text{[m/s]}$$

where:

$R_{w,b}$  = the integrating anemometer reading (kilometres) at the beginning of the measuring period.

$R_{w,e}$  = the integrating anemometer reading at the end of measuring period.

$T$  = the length of measuring period.

Example: If  $T = 10$  minutes,  $R_{w,b} = 162.5$  [km] and  $R_{w,e} = 164.69$  [km], the average windspeed is  $V_T = 3.72$  [m/s]

### Average water flow rate

Calculate the average water flow rate for each time period:

$$q_{PT} = \frac{1000 * (Q_{p,e} - Q_{p,b})}{T} \quad \text{[l/s]}$$

Where:

$Q_{p,b}$  = the integrating flowmeter reading [cubic meters] at the beginning of each ten minute period.

$Q_{p,e}$  = the integrating flowmeter reading at the end of each ten minute period.

$T$  = the length of the measuring period.

1000 = conversion factor (litres per cubic meter)

Example: If  $T = 10$  minutes,  $Q_{p,b} = 764.98$  [m<sup>3</sup>] and  $Q_{p,e} = 765.20$  [m<sup>3</sup>], then the average flow rate is  $q_{PT} = 0.35$  [l/s]

### Average rotational rotor speed

Calculate the average rotational speed of the windmill rotor for each time period:

$$n_{RT} = \frac{N_{R,e} - N_{R,b}}{T} \quad \text{[revs/s]}$$

where:

- $N_{R,b}$  = the integrating rotation counter reading at the beginning of the measuring period.
- $N_{R,e}$  = the integrating rotation counter reading at the end of the measuring period.
- $T$  = the length of the measuring period.

Example: If  $T = 10$  minutes,  $N_{R,b} = 6773$  [-] and  $N_{R,e} = 6999$  [-], then the average rotational speed  $n_{RT} = 0.39$  [rev/s]

### Average stroke rate (optional)

Calculate the average stroke rate  $n_{ST}$  of the reciprocating pump for each ten minute period:

$$n_{ST} = \frac{N_{S,e} - N_{S,b}}{T} \quad \text{[strokes/s]}$$

Where:

- $N_{S,b}$  = the integrating stroke counter reading at the beginning of the measuring period.
- $N_{S,e}$  = the integrating stroke counter reading at the end of the measuring period.
- $T$  = the length of the measuring period.

## C5 HAND PUMPS

This section covers water-pumping systems in which the prime mover is a human operating a one-person hand pump. The pump may be a reciprocating type, a rotating screw type, or a counterpoise or swing basket system.

### PUMP INSPECTION

The following inspections should be carried out. The results should be included as comments in narrative form in the logbook, with notations as to which component or part was inspected and the results of the inspection. If a component listed below is not inspected, that fact should be noted. However, unless the system is not in operating order, do not carry out any maintenance at this time based on the pre-test inspections.

Visually inspect the pump assembly. If possible, disassemble the pump assembly and inspect individual parts. Note in the logbook worn or corroded parts: for reciprocating pumps, cylinder, piston, and packing; for rotating screw pumps, screw and liner; for counterpoise or swing basket systems, inadequate counterweight or leaking baskets, etc.

Listen to and inspect the pump during normal operation. Note if the system performance during operation appears to be clearly unsatisfactory (e.g. very high force needed to operate pump, very low water flow rate, excessive leaks, excessive pump noise etc.).

Inspect system piping and valves visually. Open and close all valves. Note valves which do not operate. Note on a sketch the location and severity of leaks in valves and piping, if any. Also where possible, note the physical condition of the interior surfaces of piping and valves. Determine whether a build-up of scale or other deposits has formed that reduces the effective diameter of the pipe or that causes the interior surface to be extremely rough. Note where the wall thickness has been reduced significantly by corrosion.

#### Note:

Following inspection of the valves, it should be determined that all of the valves leading to and from the pump are in their open position prior to beginning the tests.

Inspect the storage tank if included in the system. Note any leaks. Clean the sight glass if present.

Inspect the water intake. Examine screens if they are accessible and note their condition, i.e. whether they are intact or have visible holes, whether they are clogged, etc.

For borehole wells, measure the static suction head (vertical distance from the water level in the borehole to the pump inlet when no water is being pumped and the pump has been off for at least two hours).



## **Normal Pumping Test**

With the cooperation of the normal users of the pump, observe and record the pump use characteristics over a period of 24 hours. All individuals using the pump should use the containers they normally use, and should be encouraged to fill them only to the amount that they normally do.

### Pumping time, water volume pumped and characterization of users

For each usage proceed as follows:

1. By means of the stop-watch measure the time  $T_p$  a person needs to fill her/his tin or bucket.
2. By means of the calibrated container measure the volume of the water pumped  $Q_{pp}$  by each user.
3. Determine her/his sex and age. In many cases it is not necessary to ask after the age; the class ( 7 - 11, 12 - 17, >>17) can be determined by guessing.

### Number of strokes

For reciprocating hand pumps or swinging baskets, count and record the number of strokes  $N_s$  for each usage.

### Suction head

Every hour during the day, measure and record the time (hours, minutes) and the suction head  $H_{in}$  (meters)

#### Note:

If the pump is below the water surface in the well the suction head should be recorded as a negative number.

### Discharge head

Measure the discharge head at the beginning of the day. For hand pumps it can be considered constant. Record its value in the heading of Data Sheet 4.5.1. It is the vertical distance between the pump body and the water outlet level. See also the note under suction head.

### **Preliminary Calculations:**

#### Average pumping rate

Calculate the average pumping rate  $q_{PT}$  for each pump:

$$q_{PT} = \frac{Q_{PP}}{T_p} = \text{-----} \text{ [l/s]}$$

Where:

$$\begin{aligned} Q_{PP} &= \text{the water volume pumped by the user in [l]} \\ T_p &= \text{the pumping time in [s]} \end{aligned}$$

Example: The 16th user pumped 21 l water in 75 seconds. As a result his average pumping rate is:

$$q_{PT} = \frac{21}{75} = 0.28 \text{ [l/s]}$$

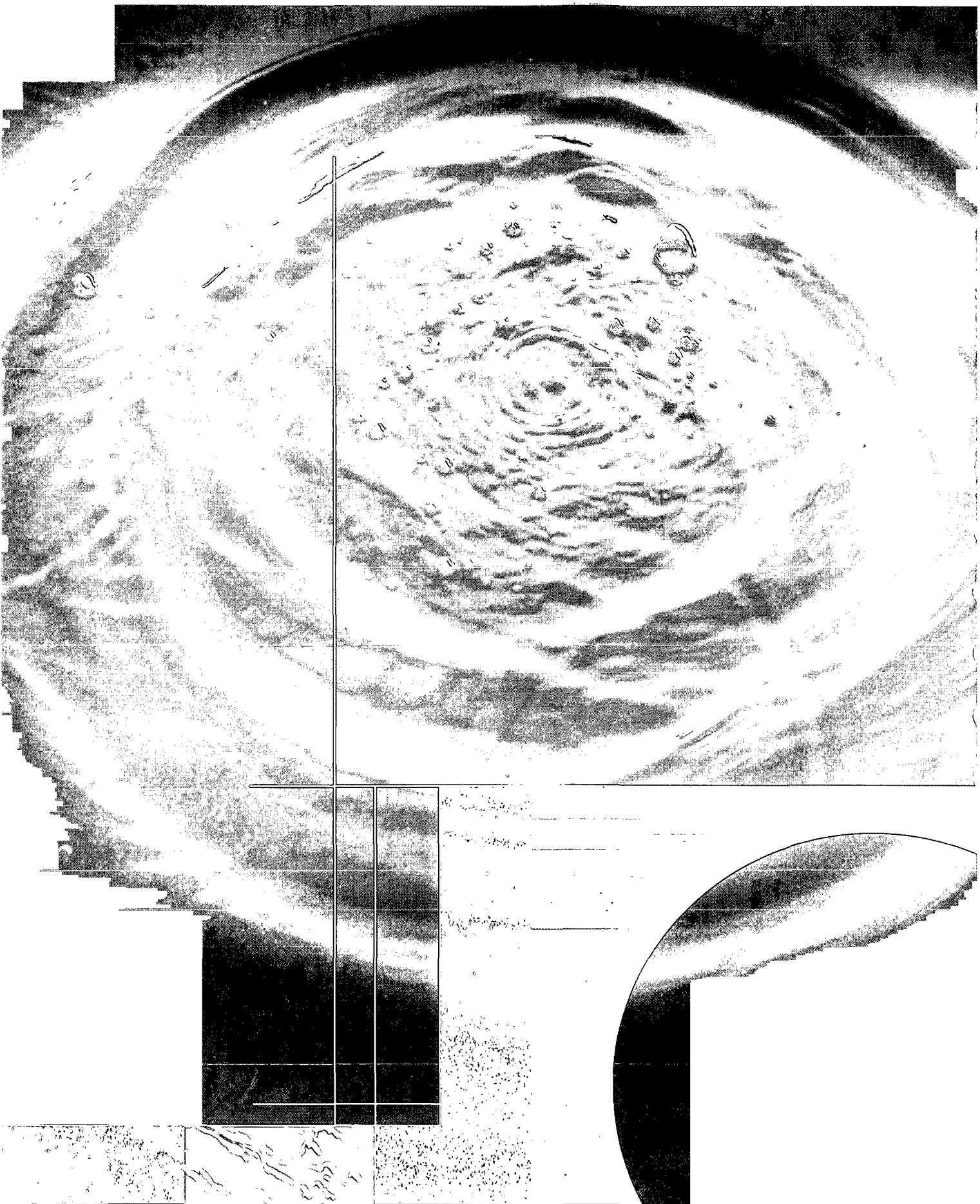

Water Research

PO Box 824, Pretoria, 0001, South Africa

Tel: +27 12 330 0340, Fax: +27 12 331 2565

Web: <http://www.wrc.org.za>

