



Rural Village Water Resources Management Project
(Nepal-Finland Cooperation)



PRODUCTION MANUAL

ROBUST ARSENIC BIO-SAND FILTER
(RCC with High Grade Concrete)

(A Manual for Production of Filter at Workshop/Factory)



August 2008

Table of Contents

1	BACKGROUND	3
2	FILTRATION SYSTEMS	3
2.1	ABF Filtration Systems.....	3
2.2	Bio-film Maturation	3
2.3	Arsenic Removal.....	4
2.4	Pathogen Removal	4
3	ABF PRODUCTION	4
3.1	Size of the filter.....	4
3.2	Concrete mix design	5
3.3	Sand for the concrete	6
3.4	Aggregate for the concrete.....	6
3.5	Cement	6
3.6	Admixtures.....	7
3.7	Water.....	7
3.8	Reinforcement.....	8
3.9	Concrete Cube test	9
3.10	Mould.....	10
3.11	Demoulding.....	12
3.12	Curing	12
3.13	Filter Materials.....	12
4	ABF OPERATION	14
4.1	Recharging of ABF Filter	14
4.2	Replacement of Iron Nails	14
4.3	Performance	14

1 BACKGROUND

Arsenic contamination in ground water is a serious public health concern in Nepal. In 2000, it has been reported that about 20 districts of Terai adjoining India are the plains forming the northern extension of the Indo - Gangetic Plain which are affected with arsenic problem. About 25% of the samples show arsenic concentrations between 10ppb to 50ppb, and in 5% of the samples the values were higher than national guideline value of 50ppb¹.

As arsenic problem was identified in the Terai districts, RWSSSP - Lumbini zone started supporting on arsenic test, GPS / GIS mapping and mitigation in its Terai districts (Nawalparasi, Rupandehi and Kapilvastu) with development of Arsenic Bio-sand Filter (ABF) technology for household level use to reduce arsenic concentration and supported 700 households for construction of ABF filters.

Rural Village Water Resources Management Project (RVWRMP) started with the financial assistance from Governments of Nepal and Finland in ten districts (Darchula, Baitadi, Dadeldhura, Bajhang, Bajura, Doti, Achham, Humla, Dailekh and Kailali from 2006. RVWRMP has a program to support arsenic affected local communities of Kailali district by implementing arsenic mitigation activities such as awareness program, supporting for construction of ABF, etc with experience from Lumbini project.

RVWRMP further improved ABF (RCC with high grade concrete model) through intensive laboratory examination, test production and improvement on the production technology. RVWRMP is implementing this improved robust ABF model in Kailali and by WaterFIN in Nawalparasi districts.

2 FILTRATION SYSTEMS

2.1 ABF Filtration Systems

The raw water causes the iron nails to rust thus creating ferric oxide. The arsenic will sorbs onto the ferric oxide particles and then percolate down the system with the water. The sand contained in the filter will trap these particles, along with the sorbet arsenic onto them. Arsenic concentration in filtered water will be reduced to 85-95% (best cases 99%) of the raw water².

2.2 Bio-film Maturation

E. coli were chosen as test parameters because they were not expected to multiply in the filter columns due to low temperatures and insufficient oxygen levels and thus could be used as tracer particles. Newly installed or recently cleaned bio-sand filters

¹ Post Evaluation of Arsenic Bio - Sand Filters in Lumbini Zone, Nepal, September 2007, RVWRMP

² Post Evaluation of Arsenic Bio - Sand Filters in Lumbini Zone, Nepal, September 2007, RVWRMP

do not effectively remove bacteria. The bacterial removal efficiency depends upon the bio-film ripeness that refers to the time necessary for the biological community to mature such that optimal bacterial and particle removal is attained. Specially, filter ripening is defined in this context as an improvement in the ability of a filter to remove *E. coli*. The biological layer typically takes two to three weeks to develop to maturity in a new filter. After this only, the removal efficiency and subsequent effectiveness of the filter increases throughout this period.

2.3 Arsenic Removal

Few fundamental chemical processes like oxidation & reduction, precipitation & adsorption are concerned for the designed arsenic removal technologies. Arsenic removal technology of ABF is based upon the adsorption process as it consists of iron nails which are found to be excellent adsorbent sites for arsenic. The iron nails are exposed to air and water, and is rusted quickly, producing ferric hydroxide particles. When arsenic contaminated water is poured into the filter, arsenic is quickly adsorbed onto the surface of the ferric hydroxide particles. These arsenic loaded ferric hydroxide particles are trapped on top of the fine sand layer. Most of the arsenic is already adsorbed on to the ferric hydroxide, and almost all ferric hydroxide is trapped on the top of fine sand layer, as a result, arsenic is effectively removed from the water. During the process of arsenic removal, iron dissolved in water is also removed through co-precipitation and filtration process.

2.4 Pathogen Removal

The pathogen in the ABF can be removed by physicochemical and biological mechanisms. A tightly packed sand bed can detain particles about 5% of the grain diameter. Many larger particles such as cysts are removed from surface water whereas the viruses and bacteria are removed by biological mechanisms. When microbially contaminated water is poured into the filter, the predatory organisms present in the bio-film will consume the invading bacteria. In addition, the biological population in the bio-film produces toxic substances to intestinal bacteria.

3 ABF PRODUCTION

3.1 Size of the filter

Shape:	Circular
Inner diameter:	400mm at top and 360mm at bottom
Wall thickness:	70mm at top and 90mm at bottom
Height:	1000mm

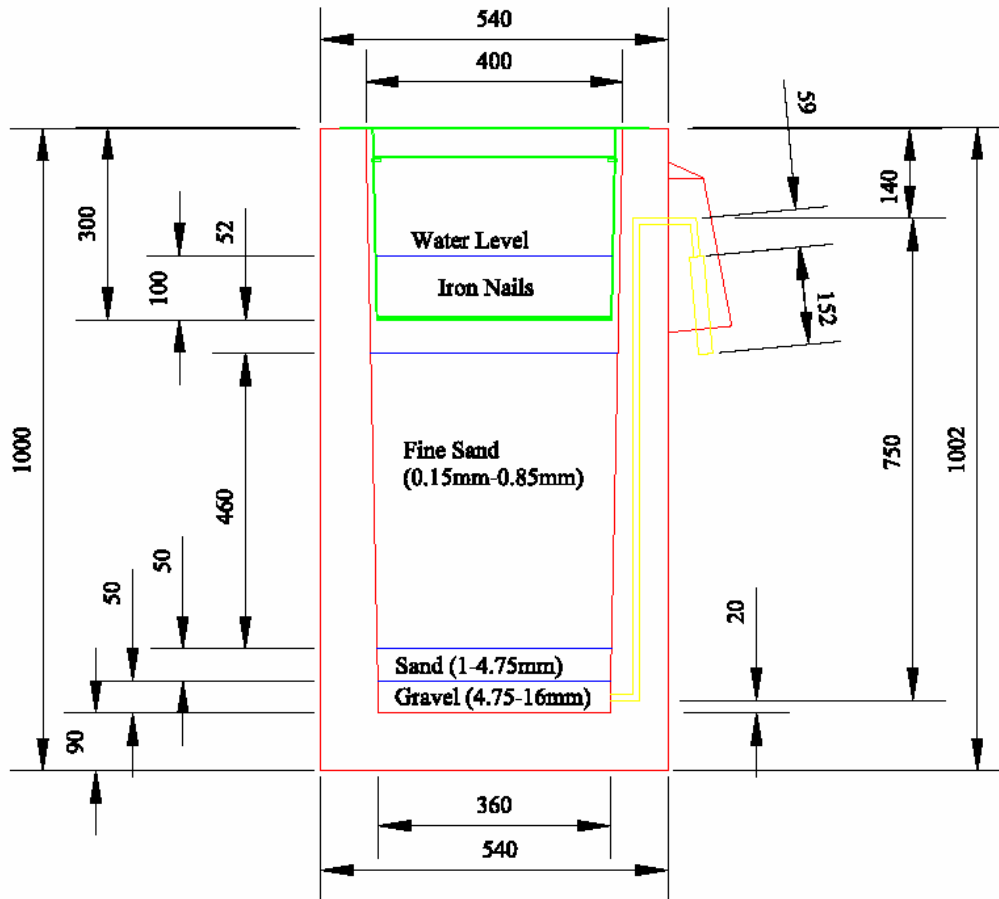

Figure 1: ABF Filter with filter materials and nail box

3.2 Concrete mix design

Concrete mix design:³

CSA mix Ratio by volume: 1:1.5:2.5

Micro-Silica: 15% of cement

Glanium 51: 1.5% of cement

Water Cement Ratio: 0.35 to 0.4

Use appropriate machines for concrete mixing.

Use electrical table vibrator for filter production.

The concrete shall be above M30 grade. Concrete strength should be tested while changing the materials and regular monthly schedule as well.

³ This Concrete mix design tested in RVWRMP laboratory. Twenty eight day compressive strength of the above mix design with 0.35 water cement ratio was found M60 in the laboratory. Compressive strength of this design is expected to be over M40 for the site works.

3.3 Sand for the concrete

Natural river sand with size smaller than 4.75mm should be used to produce the filter. If river sand contains impurities such as mud, silica, etc., it should be washed before use.

Grading of sand has significant effect on the workability of concrete that concern on water cement ratio and ultimately influence on strength of concrete. The grading of sand should fall on grade zone-I or II. Example of sand with grading zone-II is shown in the figure below. Standard Sieves of sizes 150 micron, 300 micron, 600/850 micron, 1.18 micron, 2.36 micron and 4.75 micron should used for grading test.

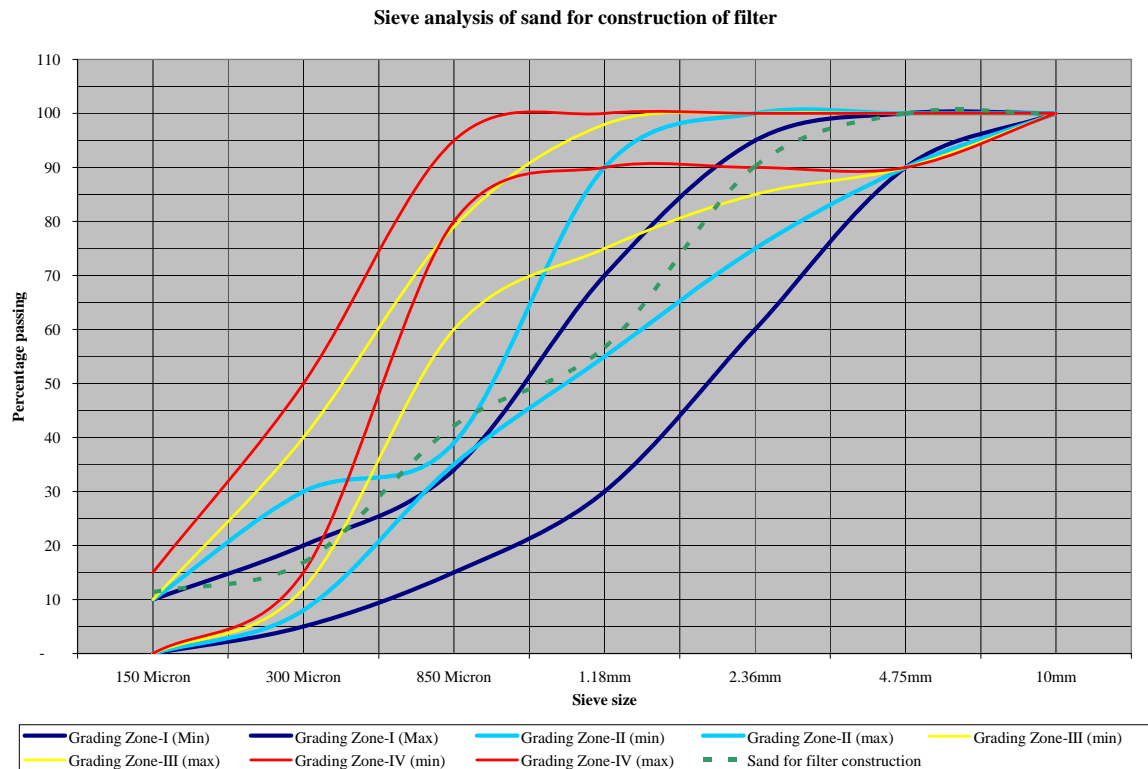

Figure 2: Grading test of Sand

3.4 Aggregate for the concrete

Natural river gravel with size between 4.75mm and 12.5mm should be used. It should be graded by using standard sieves. For very high grade concrete, natural river gravel with hard stones such as fine grained granites are preferred.

3.5 Cement

Ordinary Portland Cement or Ordinary Pozzolana Cement should be used. It should comply with Nepal Standard/Indian Standard/British Standards or equivalent.

3.6 Admixtures

The concrete mix design has been tested by adding following admixtures of produced by BASF Construction Chemical (India) Pvt. Limited, Navi Mumbai, India. www.basf-cc.co.in

1. **Micro-Silica or equivalent:** Micro-Silica (silica fume) improves the concrete quality significantly and changes the porous structure of concrete in a definitive manner and makes it denser and more resistant to any type of external influences. It has following advantages.
 - Increased density and strength of concrete
 - Improved resistance to chemical and mechanical attack
 - Prevents bleeding and segregation in fresh concrete

It should be stored under cover out of direct sunlight and protect from extreme temperature and can be used up to 12 months of production. The product shall comply with ASTM C1240.

2. **Glanium-51 or equivalent:** It is an admixture of a new generation based on modified polycarboxylic ether. The product has been primarily developed for application in high performance concrete where the highest durability and performance is required. It is free of chloride and low alkali. It is compatible with all types of cements. It has following advantages:
 - High early and ultimate strength of concrete
 - Improved adhesion to reinforcing steels
 - Better resistance to carbonation and other aggressive atmospheric conditions
 - Lower permeability and increased durability
 - Reduced shrinkage and creep

It should be stored under cover out of direct sunlight and protect from extreme temperature and can be used up to 12 months of production. The product shall comply with ASTM C494 Type F.

3.7 Water

Water shall be clean and free from detrimental concentration of acids, alkalis, salts, sugar and other organic or chemical substances. If the water used is not obtained from drinking water source, suitability of the water should be tested.

3.8 Reinforcement

Vertical main bar: 7mm deformed Tor Steel, 3 numbers in U-shape
Ring bar: 4.75mm Tor steel, 3 nos, welded 450mm rings, inside main bar
Spiral stirrups: 3.25mm @ 60mm spacing, spiral winding from outer side of main bar

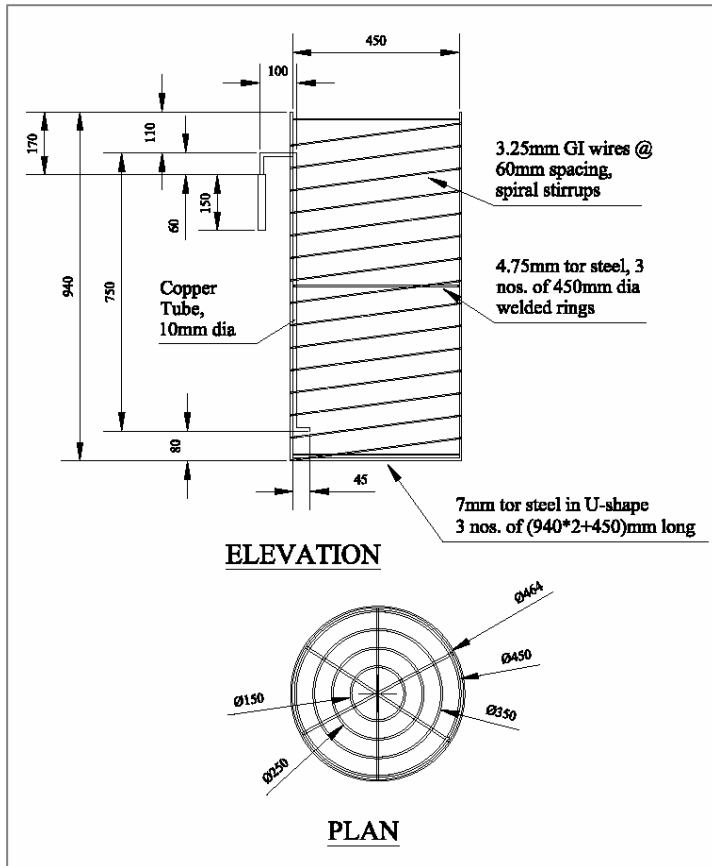

Figure 4: Reinforcement details of ABF



Figure 3: Reinforcement of ABF

Riser pipe:
 Copper tube, 10mm dia
 welded with GI Nipple at
 the outlet end to facilitate
 for ordinary water fittings.

3.9 Concrete Cube test

Concrete cubes should be prepared and tested for compressive strength when producing the ABF by using sand and/or gravel from a new river or while changing the cement brands or admixtures.

Cubes should be prepared by using standard cube moulds of size 150mm x 150mm x 150mm and the table vibrator.

Test should be carried out for 7day and 28 day, three cubes in each test.

Cube tests should also be carried out every month during normal production to ensure the quality.



Figure 5: Production of concrete cube in PSU/RVWRMP laboratory, Dhangadhi



Figure 6: Compressive Strength test of concrete cubes in a local laboratory in Dhangadhi

3.10 Mould

Inner Mould:

MS Steel, 4mm thick, (400-360mm) dia @ 2% slope, with flange, welded, one piece

Outer Mould:

MS Steel, 3mm thick, 540mm dia, with flange, welded, two halves



Figure 7: Inner Mould attached with base mould



Figure 10: Outer mould half1



Figure 8: Outer mould half2

Base Mould: MS Steel, 10mm thick, 630mmx630mm and 50mmx50mmx5mm angle frame

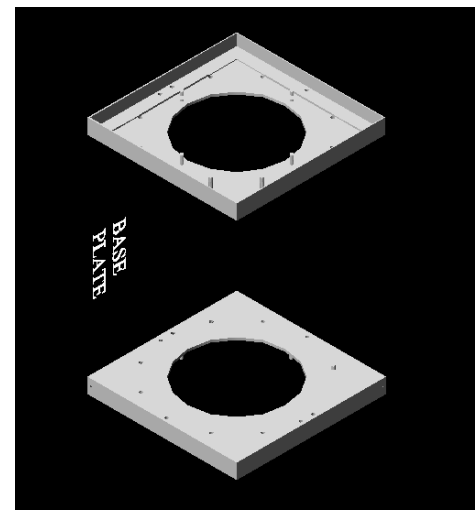
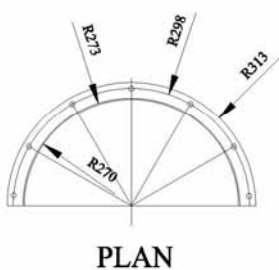
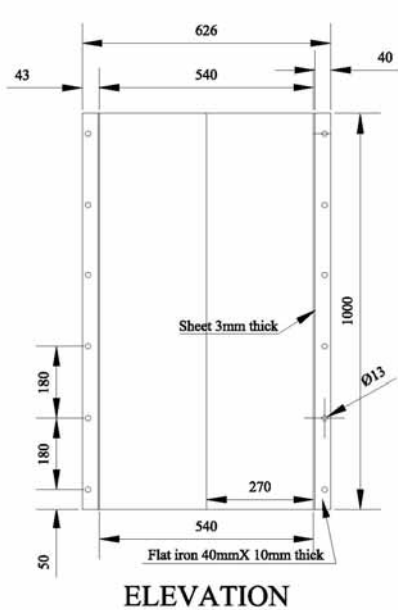
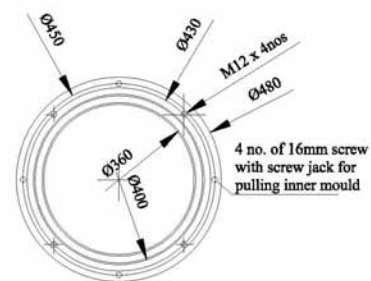
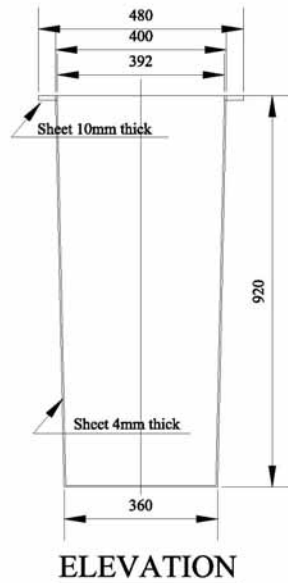
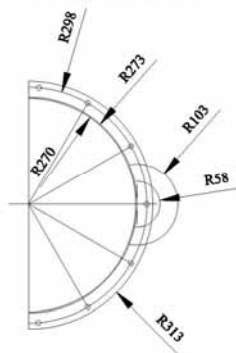
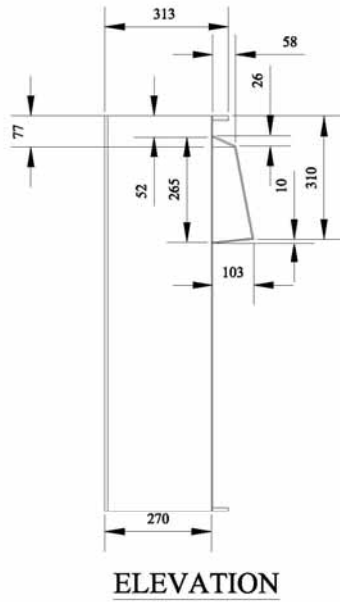

Figure 9: Base mould



OUTER MOULD



INNER MOULD

Figure 11: Outer mould details of ABF

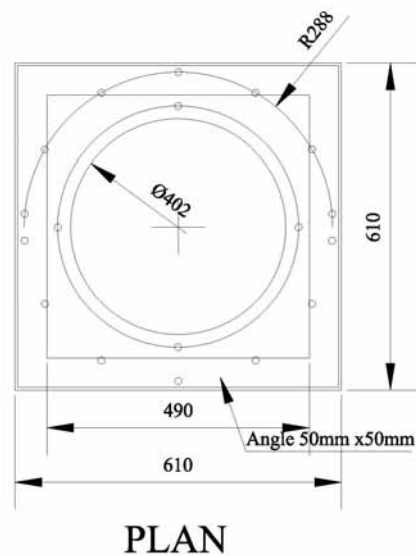
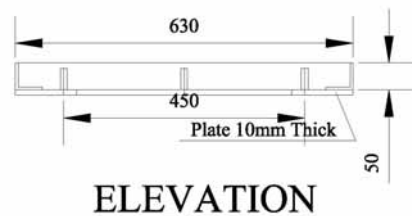

Figure 12: Base mould details of ABF

Detailed Drawings for Manufacturing of Moulds

3.11 Demoulding

De-moulding of filter will be done at 62 to 72 hours of casting. De-moulding shall be done with great care with following steps:

1. Place filter with mould upside down on a metal plate with the help of chain pulley crane
2. Pull Inner mould with the help of four crewed bolts
3. Take out the base plate
4. Unlock nut-bolts of side moulds and slide out both halves

3.12 Curing

After de-moulding, place the filter into a water tank with the help of chain pulley crane pulling from metal base plate without applying force on the filter. Curing should be done dipping into water pond for 14 days.

The filter shall be taken out of the water pond after 14 days and filled shall be stored filled with water or can be installed into households, fill up with filter materials and start operation. The filter shall not be kept dry in any case. The filter shall be kept in a shade protected against direct sunlight during storage or operation.

3.13 Filter Materials

Filter materials shall be graded by using Indian Standard Sieves. Grading of filter materials shall be as follows.

Gravel: 4.75mm to 16mm size

Coarse sand: 1mm to 4.75mm size

Fine sand: 150 Micron to 850 Micron

The natural river sand of local rivers can be used for filter materials. If the river sand contains impurities such as mud, silica, organic materials, etc., it should be washed thoroughly.

Filter Material details

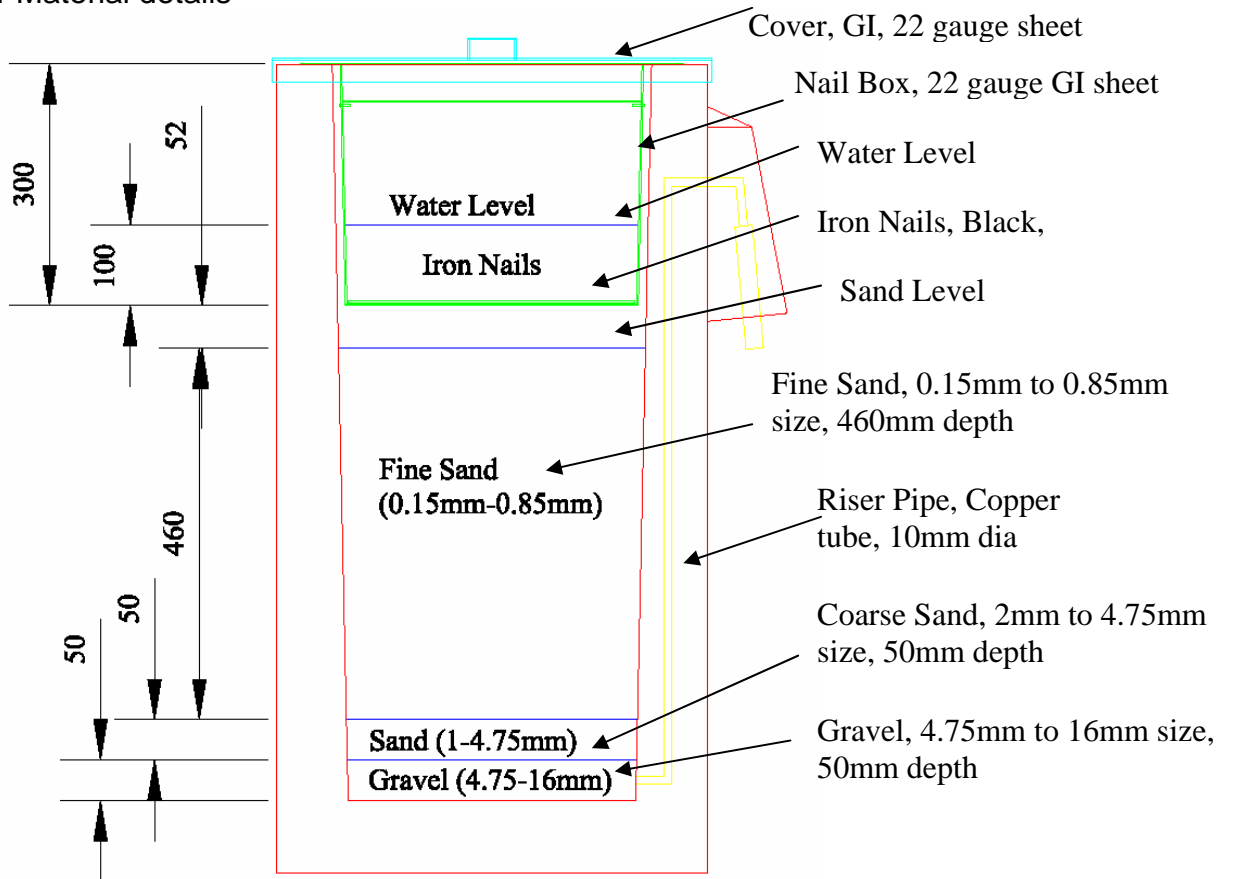

Figure 14: Filter Material details of ABF

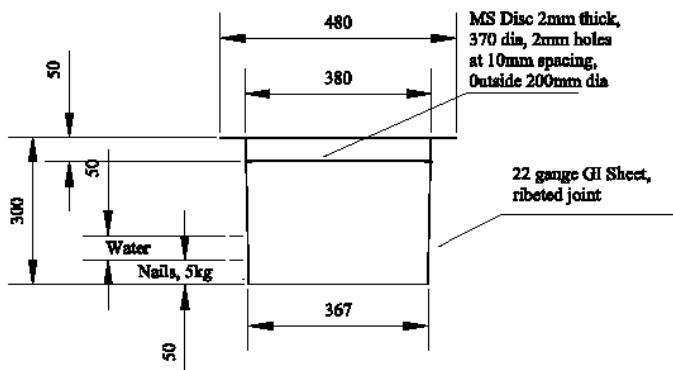

Figure 15: Nail box details

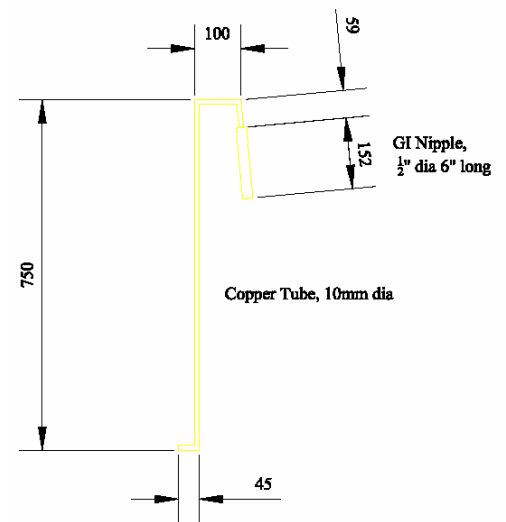

Figure 16: Riser Pipe

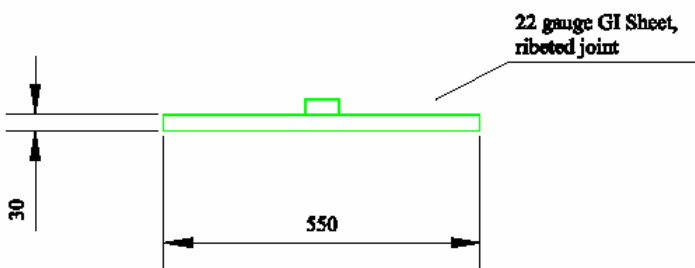

Figure 17: Filer cover details

4 ABF OPERATION

4.1 Recharging of ABF Filter

With time and use the surface of the filtering media will accumulate inorganic and organic material that will plug the pores and decrease the flow rate through the BSF. The ABF does not exhibit breakthrough of untreated water - it cannot - the flow gradually decreases as the pores are plugged. Untreated water is not forced through that portion of the filter media responsible for treating the water. In fact, as the flow through the ABF decreases the quality of the filtered water increases. When the production of filtered water is unsatisfactory (too low) it is time to clean (maintain) the filter media. First, the filter lid and nail box containing iron nails are removed. Then the top sludge layer to maximum 2cm depth is agitated stirring gently by fingers. As a result of agitation, the stagnant water above the sand will become turbid slurry. Then remove that turbid slurry carefully using a small container. Replace the nail box and slowly add water to check the flow rate. This process shall be repeated to regain the desired flow rate, however agitation should not go deeper than top 2cm layer. Finally the nail box containing the iron nails is shaken to make sure that the iron nails cover the whole surface of the basin and then put back into the filter.

So, recharging of ABF is so simple to improve the filtration rate again. There are no moving parts that require skill to operate. When the flow through the filter becomes too low after clogging with debris, the maintenance consists simply of washing the top layer of sludge over the sand.

4.2 Replacement of Iron Nails

The time necessary to change iron nails depends on arsenic concentration and water consumption. If the arsenic concentration is very high, the life time of nails is shorter. The other parameters of the water may have also some influence to time for changing nails. The time varies normally from 2 to 5 years, average 3 years.

4.3 Performance

The efficiency tests shows that this filter removes more than 95% arsenic on an average and 99% in most of the cases⁴. In some cases, the removal is not that efficient as expected as the filtration unit was not used properly, i.e. iron nails placed in the tray were not spread properly for water to get contact with the nails. The filter also shows high level of iron removal as well as high flow rate (as high as 30Litre/hour). Microbial quality of this treated water is satisfactory. The technical performance of filter is studied on the social & technical aspects by various organizations (MIT, ENPHO, RWSSSP, CAWST) and universities from 2000 - 2005.

⁴ *A comprehensive Report on Groundwater Arsenic Contamination - RWSSSP Program Area*

Table 4.1: Performance Tested Efficiency of ABF

Parameters	Performance Range	Remarks
Arsenic removal	85% - 95%	Proper quantity, placement and proper washing of iron nails, sand, gravels is important
Iron removal	90% - 95%	
Coliform removal	80% - 99%	Proper washing, amount of water and water level at top (minimum 5cm) is essential, bio - film should not be destroyed so frequent washing without need is not advisable
Turbidity removal	80% - 95%	-
Flow rate	15 – 20 Litre/hour	Flow rate of filtered water can be increased by proper washing of sludge.
Iron nails (filter media)	Replace nails after 2 to 5 years	Clogging can be reduced by proper washing of nails. Life of nails depends upon arsenic concentration and water consumption rate.

The different efficiency tests show that this type of filter removes average at least 85-95% arsenic, even 99%. So far the filter has removed arsenic from raw water of concentration 20-580 ppb. However, it is not recommended to use this type of the filter for raw water, arsenic concentration more than 500 ppb, because maintenance will be too complicated due to quick clogging/need for extremely frequent flushing as well as need to change nails even after a few months.