

Chlorinating small water supplies

A review of gravity-powered and water-powered chlorinators

A WELL study produced under Task 511
by Brian Skinner

WELL
Water and
Environmental Health at
London and
Loughborough

London School of Hygiene and Tropical Medicine
Keppel Street
London
WC1E 7HT

WELL@lshtm.ac.uk
www.lboro.ac.uk/WELL

Water, Engineering and Development Centre
Loughborough University
Leicestershire
LE11 3TU UK

WEDC@lboro.ac.uk
www.lboro.ac.uk/WELL

© LSHTM/WEDC, 2001

Skinner, B.H. (2001)

Chlorinating Small Water Supplies – A review of gravity-powered and water-powered chlorinators
WELL.

Contents amendment record

This report has been issued and amended as follows:

Revision	Description	Date	Signed
0	Draft Final	27/06/01	APC
1	Final	01/10/01	APC

Designed and produced at WEDC
Task Management by Andrew Cotton
Quality Assurance by Andrew Cotton
Cover photograph: WEDC

Summary

Scope

This WELL study paper focuses on the use of chlorination for disinfection of water in small water supply systems in low- and middle-income countries. The text concentrates on the use of gravity- or water-powered systems that can be used where electricity is either unreliable, or is not available - a situation that often applies to small schemes, in developing countries.

The use of chlorine gas for disinfection is not considered in this paper, partly because chlorine gas is not usually readily available in many areas of low- and middle-income countries. Another reason is that chlorine is a very poisonous gas and the risks associated with safely transporting and using it in small water treatment installations mean that it is not usually appropriate for such facilities.

The initial intention was to gather information from literature and to gather reported experiences from field practitioners. The widely publicised requests for information from the field did not result in a large number of responses.

Since the length of the paper is limited the reader is regularly directed to other sources of information for details that can not be covered in this report.

Contents

The introduction sets chlorination in its right context. It suggests that the best quality sources of water should be used and that hygiene education is often needed to encourage consumers to protect chlorinated water between collection and consumption. The alleged health risks from the by-products of chlorination, and the problem of chlorine resistance by some pathogens are also briefly examined.

The second section of the report introduces chlorination and the variables that affect its efficacy. The next two sections describe the use of gravity-driven, water-powered and diffusion chlorinators, and advise on the selection of chlorinators for small water supplies. Two tables are provided to assist selection for different water sources, flow regimes and local constraints.

Useful information about suppliers of simple chlorinators, test equipment, and small electrolysis units for the production of sodium hypochlorite is provided in Appendix 1. Appendix 2 briefly mentions the recent development of simple electrolysis units that can be used to produce sodium hypochlorite from brine made from common salt and water.

Conclusion

Chlorination is still the most practical form of disinfection of small water supplies. A wide variety of non-electrically powered chlorinators exist and some of these can be made using fairly basic materials. Technology is now available that makes the production of sodium hypochlorite in low- and middle-income countries possible at regional, district or even village level. This removes some of the previous constraints preventing the adoption of chlorination.

It is hoped that this study paper will contribute to the increased adoption of chlorination for the disinfection of water. As a result many thousands of consumers may be better protected from the water-borne diseases carried in the untreated sources of water that they presently consume.

Table of contents

Summary	i
Scope.....	i
Contents	i
Conclusion	i
Table of contents	iii
Table of boxes	v
Table of tables	v
Table of figures	v
1. Introduction	1
1.1 Scope	1
1.2 Associated Issues	1
1.2.1 Other methods of disinfection	1
1.2.2 Choosing and protecting the source	2
1.2.3 The importance of health and hygiene.....	2
1.2.4 Alleged health risks of by-products from chlorination.....	2
1.2.5 Taste and odour problems.....	3
1.2.6 Resistance of some pathogens to chlorination	3
1.2.7 Small-scale production of sodium hypochlorite.....	3
1.2.8 Mixed oxidants.....	3
2. Chlorination.....	5
2.1 Introduction to chlorination	5
2.2 Sources of chlorine.....	6
2.3 Chlorine dose	7
2.4 Contact Time and CT Value	8
2.5 Some of the general problems arising with the use of chlorinators	8
2.5.1 Precipitates, crystallisation and scaling	8
2.5.2 Corrosion	10
2.5.3 Availability and stability of chlorine compounds, and risks from additives	10
2.5.4 Handling precautions and transportation	11
2.5.5 Accuracy of preparation of solutions for dosing	11
2.5.6 Accuracy of the amount of solution dosed	13
2.5.7 Accuracy of the estimate of the flowrate of the water to be treated	13

2.5.8	Mixing of the dose with the water to be treated	13
2.5.9	Ensuring effective contact time	14
2.5.10	Testing for chlorine concentration	14
2.5.11	Changes in water level and water pressure	15
2.5.12	Provision of on/off features and anti-siphon valves	16
3.	Chlorinators for small systems.....	17
3.1	Introduction.....	17
3.2	Gravity-driven chlorinators	17
3.2.1	Mariotte Jar.....	18
3.2.2	Inverted bottle with water seal	18
3.2.3	Constant-head tanks.....	19
3.2.4	Inverted bottle with floating valve.....	19
3.2.5	Floating draw-off.....	19
3.2.6	Vandos chemical feeder	21
3.3	Water-powered chlorinators	21
3.3.1	Wheel feeder dosers.....	21
3.3.2	Float-powered chemical doser.....	22
3.3.3	Hydraulic motor/piston driven dosers.....	22
3.3.4	Venturi-powered dosers.....	22
3.3.5	Direct suction dosers	23
3.3.6	Displacement-bag doser	23
3.4	Diffusion chlorinators.....	24
3.4.1	Pot chlorinators and floating chlorinators.....	24
3.4.2	Continuous flow diffusers.....	25
3.4.3	Intermittent flow diffusers.....	26
4.	Selection of chlorinators	28
4.1	Selection criteria.....	28
4.1.1	Nature of the flow of the water to be treated	28
4.1.2	Origin of the doser and its operation/maintenance requirements	28
4.1.3	Types of chlorine compound available.....	29
4.1.4	Ability of doser to cope with changes in water level, solution level or water pressure	29
4.2	Chlorinator options for different sources of water	29
4.2.1	Open wells	29
4.2.2	Boreholes	30

4.2.3 Springs	30
4.2.4 Surface water.....	32
4.2.5 Rainwater	32
5. References and Bibliography	33
5.1 References.....	33
5.2 Other books and papers.....	35
5.3 Some sources of information about chlorination on the world-wide web	35
Appendix 1. Sources of Further Information.....	37
Appendix 1.1 Some suppliers of small-scale non-electrical chlorinators.....	39
Appendix 1.3 Some suppliers of equipment for the production of sodium hypochlorite from the electrolysis of brine	43
Appendix 2. Production of Sodium Hypochlorite by Electrolysis of Brine	45
Appendix 3. Simplified Illustrations of Chlorinators	47
Table of boxes	
Box 1. Definitions of Demand, Residual and Dose.....	5
Box 2. Techniques of chlorination	6
Box 3. Calculations for preparing solutions and applying chosen doses	12
Table of tables	
Table 1. Chlorine compounds	7
Table 2. The main variables affecting chlorination	9
Table 3. A comparison of small-scale chlorinators against certain selection criteria	27
Table 4. Likely appropriateness of chlorinators for different water sources.....	31
Table of figures	
Figures 3.2 to 3.4, which relate to Section 3, are presented in Appendix 3.	

1. Introduction

1.1 Scope

This WELL study paper focuses on the use of chlorination for disinfection of water in small water supply systems in low- and middle-income countries.

The text concentrates on the use of gravity- or water-powered systems that can be used where electricity is either unreliable, or is not available - a situation that often applies to small schemes, in developing countries. Where electricity is available, electrically powered chlorinators, such as dosing pumps, can be used for large or small schemes. It has not been possible to consider such chlorinators within the scope of this short study. Information about them can be obtained from many other sources, particularly manufacturers. Electric dosing pumps that can be operated by battery are available. Systems where the electricity is only needed for a control system, rather than for pumping, are also on the market and these use only a small amount of battery power. However, because of the added complications of the recharging of the batteries, no battery-powered systems are considered in this publication.

The use of chlorine gas for disinfection is not considered in this paper, partly because chlorine gas is not usually readily available in many areas of low- and middle-income countries. Another reason is that chlorine is a very poisonous gas and the risks associated with safely transporting and using it in small water treatment installations mean that it is not usually appropriate for such facilities. Much is written elsewhere about disinfection using chlorine gas (e.g. White 1999) which is in use in many large treatment works.

The initial intention was to gather information from literature and to gather reported experiences from field practitioners. The widely publicised requests for information from the field did not result in a large number of responses, possibly indicating that gravity- or water-powered systems are not widely used.

The author is very thankful to those who provided the information used for preparing this report. It is hoped that this publication will increase adoption of small-scale chlorination systems where they are appropriate, leading to an improved quality of water for many consumers. Feedback on the contents of the report will be welcomed.

1.2 Associated Issues

Before considering the subject of chlorination of small water supplies it is important to briefly consider some associated issues:

1.2.1 *Other methods of disinfection*

Disinfection, which is the process of destroying or inactivating pathogenic (disease causing) organisms, can be accomplished by a number of methods, both physical and chemical. This report has focused only on chemical treatment by chlorine because this is the most widely used water disinfectant. Chlorination also has the advantage that when it is properly applied it provides residual protection in the water against potential low levels of post-treatment contamination. This residual protection is not provided by most other methods of disinfection.

Other methods of disinfection for piped supplies include use of ozone or ultraviolet radiation but neither is likely to be appropriate for small communities in developing countries.

Natural disinfection of water using sunlight is now practised in some developing countries. Since this is a fairly recent development, not yet mentioned in many publications, it is worthy of mention here. It is carried out at household-level by nearly filling clear plastic or glass bottles with water and exposing them to bright sunlight for at least 5 least five hours. The ultraviolet component of

the sunlight and the rise in temperature combine to result in the death of most, if not all, pathogenic organisms. (SODIS, 2001). Periodic shaking of the bottle to entrain air in the water has been found to increase the rate of destruction or inactivation of the pathogens (Reed, 1997).

1.2.2 Choosing and protecting the source

Where possible sources of water that do not need disinfection should be used in preference to polluted sources such as water from rivers and ponds. People may need to be persuaded to use such sources since their preference may be for the taste of their traditional sources. Groundwater, particularly if it is from a properly protected borehole, is usually much safer than surface water. Users can often pollute groundwater in an open, large-diameter well even if the well is properly protected. This risk should be reduced as much as possible by using hygienic methods of water collection such as covering the well and fitting a sustainable handpump.

The presence of organic matter and suspended solids adversely affects chlorination and can result in problems with taste and odour. Wherever possible, sources that have high levels of these contaminants should be avoided. Where there is no alternative, some additional form of treatment needs to be provided.

1.2.3 The importance of health and hygiene

Non-water routes can also transmit many of the water-borne diseases. This means that disinfecting drinking water will not automatically prevent such diseases. Therefore, to reduce the incidence of these diseases, improvements in the users' hygiene and sanitation practices will usually need to take place alongside improvements to their water supply. This is particularly the case where the disinfected water can be re-contaminated during collection, transportation, storage or drawing for consumption.

The risk of post-treatment contamination is nearly eliminated by chlorinating at household level and then storing it safely. Interesting results have been obtained from taking this approach in various countries. Families that used the CDC-promoted 'Safe Water System' in Bolivia and Zambia had between 44% and 54% fewer episodes of diarrhoeal diseases (CDC, 2000).

Unless disinfected water is readily available whenever a person wants a drink s/he is likely to drink water from other, possibly polluted, sources. To avoid this tendency, people need to understand the risks associated with consuming other sources of water. Appropriate health education activities are often necessary to help people appreciate the importance of consuming only good quality water.

1.2.4 Alleged health risks of by-products from chlorination

There has been considerable publicity in the West over the health risks (primarily cancer) that could potentially arise from certain by-products that may result from the disinfection of water. These disinfection by-products (DBPs) are more likely to be present if organic matter is present in the water before it is chlorinated. Most experts consider that these risks are minimal compared to the known risk of consuming water that has not been disinfected. As stated by WHO (1993, p93):

Where local circumstances require that a choice must be made between meeting either microbiological guidelines or guidelines for disinfectants or disinfectant by-products, the microbiological quality must always take precedence, and where necessary, a chemical guideline can be adopted corresponding to a higher level of risk. Efficient disinfection must never be compromised.

The level of disinfection by-products can be reduced by optimising the treatment process, particularly by removing organic substances before the water is chlorinated.

Further information on the risks of by-products from chlorination can be found in Craun (Ed.) (1996). That publication reports on a symposium of experts that met in Buenos Aires in 1994. The symposium noted that:

In the light of the concern of some groups and individuals about the possible carcinogenicity of chlorination by-products, it should be recognised that the International Agency for Research on Cancer (IARC) has concluded after extensive review and analysis of scientific reports on this subject, that there is inadequate evidence for the carcinogenicity of chlorinated drinking water in humans and in experimental animals (Craun (Ed.), 1996, p15)

Other disinfection processes can also cause potentially harmful by-products.

1.2.5 Taste and odour problems

The odour and taste of chlorinated water can cause people to reject it, particularly if they have previously only drunk untreated water. The taste or odour may result from poor chlorination practices. Chlorine taste or odour is sometimes the result of too little chlorine rather than too much.

If, despite good treatment practices, water is still being rejected on the ground of taste or odour, then appropriate health education activities should be carried out to encourage people to value the treated water over untreated alternatives.

1.2.6 Resistance of some pathogens to chlorination

Pathogens found in water, in order of general susceptibility to destruction or inactivation from chlorine, are: vegetative bacteria, viruses, protozoan cysts and oocysts, and finally bacterial spores (Witt and Reiff (1996)). However, the effectiveness of chlorination at destroying or inactivating these organisms varies depending on: the species of organism, the temperature and pH of the water, the chlorine concentration, the presence in the water of ammonia or other substances that react with chlorine, the contact time (see Section 2.4) and the method of application. Unfortunately *Giardia* and especially *Cryptosporidium parvum* cysts are highly resistant to normally used levels of free chlorine (see Sections 2.1 and 2.4) and even more so to chloramines (Witt and Reiff, 1996). Fortunately, if sedimentation (preferably after coagulation and flocculation) and filtration precede chlorination there is little risk of *Giardia* or *Cryptosporidium parvum* being in the water which is to be chlorinated. As mentioned in Section 2.3 these treatment stages are always advisable where surface water is being used as the source.

1.2.7 Small-scale production of sodium hypochlorite

In the past, the problem of obtaining a reliable supply of the chemical compounds needed for disinfection often meant that small-scale chlorination was not feasible. However, recent developments have meant that small-scale manufacture of sodium hypochlorite (from the electrolysis of salt solution, using simple, low cost equipment at local centres) is now often feasible. This system can be used wherever sodium hypochlorite is needed. For example it is promoted in conjunction with the Safe Water System mentioned in Section 1.2.3.

Appendix 2 of this report provides more information about on-site generation of sodium hypochlorite, which is possible where electrical power is available.

1.2.8 Mixed oxidants

In recent years there has been increasing use of mixed oxidant gases and solutions for disinfection, particularly in South America (Witt and Reiff, 1996, p155-160). These disinfectants are also produced from the electrolysis of a solution of salt (sodium chloride) but the freshly produced gas, or solution, is immediately injected into the water. The gas systems are called MOGGOD (mixed oxidant gases generated on-site for disinfection) systems. The more recently

developed devices produce a mixed oxidant solution instead of a gas are often called MOGOD systems. The electrolysis results in a mixture of oxygen and chlorine species that act synergistically as a powerful oxidant and disinfectant. Their effectiveness appears to meet or exceed that of chlorine and it is suggested that the risk of the formation of harmful by-products is less than from using only chlorine (Witt and Reiff, 1996, p155-160).

Since there is not yet extensive experience reported of use of the MOGOD system and power is needed at the site where it is dosed, the system is not discussed further in this report. Further sources of information can be found in the resources listed at the back of this report. Field experience of a MOGGOD unit is briefly reported in Pearson *et al.* (2000).

2. Chlorination

2.1 Introduction to chlorination

For full details of the chemistry of chlorination and use of chlorine for disinfection see relevant textbooks such as White (1999).

The chlorination of drinking water takes place when chlorine is dosed into the water as a gas, in a liquid compound or in a solid compound. This immediately produces acids and ions that will react in various ways with the water and anything it contains:

- Firstly some of the acids and ions are used up in chemical reactions with organic and inorganic matter
- Secondly, any remaining acids and ions act as a disinfectant which kills most pathogenic organisms over a period of time
- Thirdly, if more than sufficient chlorine was added for successful disinfection, then, after disinfection is complete, there will still be some remaining acids and ions in the water. These usefully continue to protect the water from low levels of future contamination by any pathogens and nuisance bacteria (Section 2.5.10).

Hence, when a **dose** of chlorine is added to water it will first react with any organic and inorganic matter and then it will begin to destroy any organisms. Therefore sufficient chlorine needs to be added to meet the **demand** made by both the chemical reactions and for the subsequent destruction of micro-organisms. In addition, for the future safety of the water, a **residual** amount of chlorine should also remain after the water has been successfully disinfected. Box 1 defines these terms. They are usually measured in terms of milligrams of chlorine per litre of water (mg/l) which is the same as parts per million (ppm).

Box 1. Definitions of Demand, Residual and Dose

- **CHLORINE DEMAND:** The amount of chlorine consumed in reactions with substances in the water
- **CHLORINE RESIDUAL:** The amount of residual chlorine remaining after the specified period of disinfection (Section 2.4) It usually should refer to *free* residual chlorine rather than to *combined* residual chlorine (see Box 2).
- **CHLORINE DOSE:** The amount of chlorine that needs to be added to the water to meet both the chlorine demand and the level of chlorine residual required.

$$\text{Chlorine dose} = \text{chlorine demand} + \text{chlorine residual}$$

The acids formed are hypochlorous (HOCl) and hydrochloric (HCl) acid. The hypochlorous acid has particularly good microbicidal properties. The exact mechanism is not known but a commonly held theory is that it kills by penetrating the walls of an organism to disrupt its metabolic activities.

Some of the hypochlorous acid dissociates into hydrogen (H^+) and chloride (OCl^-) ions. The chloride ion is not so effective at killing microbes as the hypochlorous acid because its negative charge means that it can not easily penetrate the cell wall. In fact its germicidal efficiency is at least 80 times less than that of HOCl. There is a dynamic equilibrium between the two forms of chlorine and the proportion of HOCl and H^+ OCl^- depends on the pH of the water. When the water is alkaline, H^+ is low, so to maintain equilibrium OCl^- has to be high. Conversely, when the water

is acid, HOCl predominates and disinfection is more rapid. At pH5 virtually all of the residual is HOCl, at pH7.5 about half of it is HOCl and at pH 9 virtually all of it is OCl⁻. Thus a high pH is undesirable and WHO (1993 p127) therefore recommends that for effective disinfection the pH should always be below 8.0.

Maintaining the presence of chlorine in the water whilst it is in a piped distribution system is advantageous. One way of achieving this is to ensure that it combines with ammonia to produce monochloramine (NH₂Cl) which will persist for a long time in the distribution system. This monochloramine does not generate any taste-producing compounds and is less detectable by taste than chlorine, so it may be dosed at higher concentrations. However, its germicidal efficiency is less than that of OCl⁻, and very much less than that of HOCl. It may require a contact time of two hours or more to disinfect water. If the water lacks sufficient ammonia it may be necessary to dose this (e.g. by adding ammonium sulphate or ammonium chloride), to form sufficient monochloramine. Dosing of such compounds adds extra complications to treating small water supplies and is not discussed further in this report.

Box 2. Techniques of chlorination

The principal chlorination practices of relevance to small water supplies are:

FREE RESIDUAL CHLORINATION: where the available residual chlorine (the chlorine in the water after a specific period of time) is either in the HOCl or OCl⁻ form.

- **Breakpoint chlorination:** a form of free residual chlorination where all the chlorine demand in the water is removed. The chlorine dose is sufficient to rapidly oxidise all the ammonia nitrogen in the water, and to leave a suitable free chlorine residual available to protect the water against low levels of re-contamination. Such contamination can potentially take place as the water is passing through the distribution system to the consumer, or in transit to storage in the household before consumption. The dose is also sufficient to prevent the formation of those substances causing tastes and odours in the treated water that would be present at lower doses. Breakpoint chlorination is the practice in systems where the raw water contains sewage effluents.
- **Marginal chlorination:** another form of free residual chlorination used where the water is already of a fairly high quality so has little or no chlorine demand. Sufficient chlorine can therefore be dosed to produce a free residual without the complications of a high chlorine demand from substances in the water.

COMBINED RESIDUAL CHLORINATION: where the available residual chlorine is in the chloramines form (i.e. in chemical combination with ammonia or with organic nitrogen compounds). This technique is also called chloramination. If ammonia needs to be added this complicates the application of this treatment system.

2.2 Sources of chlorine

The usual sources of chlorine and the typical chlorine content as a percentage by mass are shown in the Table 1. As discussed in Section 2.5.3 the stability and ease of use of each compound differs. Appendix 2 briefly describes recent developments in the small-scale production of sodium hypochlorite from the electrolysis of salt.

Table 1. Chlorine compounds

Compound	Common name(s)	Chemical Formula	Form	Typically dosed as	% active chlorine by mass
Dilute sodium hypochlorite	<i>Household bleach, eau de Javel, Jik</i>	a solution of sodium hypochlorite	liquid	solution	1 – 5
Sodium hypochlorite		NaOCl	liquid	solution	10 - 15
Chlorinated lime	<i>Bleaching powder or chloride of lime</i>	CaO·2CaOCl ₂ ·3H ₂ O	solid*	solution	25 - 35
Calcium hypochlorite	<i>HTH, High-test hypochlorite</i>	Ca(OCl) ₂ ·4H ₂ O	solid*	solution	60 - 70
Chlor-organics		Various	solid*	powder or solution	60 - 90
Chlorine		Cl ²	gas or liquid	gas	100

Source: Compiled from Solsona (1990), Hofkes (Ed.) (1981) and Shulz & Okun (1984)

* the solid can be in the form of powder, granules or tablets depending on the compound

2.3 Chlorine dose

To determine the appropriate amount of chlorine solution (the 'dose') needed to disinfect water from a particular source it is first necessary to find the chlorine demand of the water. This can be established by following these steps:

- divide a sample into say six 100ml sub-samples and put each in different vessel
- add different measured amounts of 100 ppm chlorine solution (i.e. 100 mg of Cl per litre of water) to each vessel. For example one could use incremental steps of 0.5 ml with this amount being added to the first, 1.0ml to the second etc. After adding the chlorine solution each sample should be well stirred.
- leave the sample for the required contact period in a cool place and out of direct sunlight.
- after the contact period has expired, take a sample of water from the first vessel and test it for the presence of residual chlorine (see Section 2.1). If there is no residual chlorine then test the water in the next vessel, and so on, until residual chlorine is first detected. This indicates that in that particular vessel the chlorine demand has been met. If for example it is first detected in the vessel to which 2.0 ml of the solution was added but is not found in the previous vessel (to which 1.5ml was added) then the chlorine demand is at least 1.5ppm but less than 2ppm (2mg/litre).

The chlorine demand of water sources will not necessarily remain constant. It will almost certainly vary for surface water sources, depending on the recent pattern of rainfall run-off contributing to the source. If the water to be treated contains a high level of suspended solids (i.e. it is turbid) there are two likely results. Firstly, much of the chlorine dose can be wasted because of chemical

reactions with the suspended solids (particularly organic substances) and secondly micro-organisms in cavities inside some of the suspended particles may not be fully exposed to the full germicidal effects of the chlorine. This is why some form of treatment prior to disinfection is always advisable where unprotected surface water is to be chlorinated. Some micro-organisms that are fairly resistant to chlorination may be found in unprotected surface water sources so in any case, at least filtration and possibly other forms of treatment prior to chlorination may need to be provided to remove these (Section 1.2.6).

2.4 Contact Time and CT Value

Two of the important variables (see Table 2) that control the effectiveness of chlorination are the concentration of the chlorine and the time during which the organisms are exposed to it. Therefore usually both a time of contact with the chlorine and a residual concentration are specified to ensure effective chlorination.

The product of the concentration of chlorine in mg/l and the contact time in minutes is called the 'CT value' or 'exposure value'. This is sometimes used to specify the exposure time and amount of chlorine needed to inactivate a particular micro-organism under specified conditions (such as temperature and pH). To satisfy the CT requirement a number of combinations of time and dose can be used, as long as the product is equal to or greater than the CT value. CT values are quoted either for free chlorine or for preformed chloramines (EPA, 1990a). The chloramine CT figures are always many times higher than the corresponding ones for free chlorine because, as previously mentioned, chloramines are far less effective as germicides.

To simplify matters, WHO (1993, p24) first gives recommendations for the various forms of treatment prior to chlorination (similar to those mentioned in Section 1.2.6 in this report) that are needed for unprotected surface water and unprotected groundwater sources, and then states that:

Terminal disinfection must produce a residual concentration of free chlorine of ≥ 0.5 mg/litre after at least 30 minutes of contact in water at $pH < 8.0$, or must be shown to be an equivalent disinfection process in terms of the degree of enterovirus inactivation ($>99.99\%$)

WHO (1993) says that this recommendation is expected to result in 'negligible virus risk' and normally will ensure that the water has negligible risk of transmitting parasites. *E. coli* bacteria, which are indicators of faecal pollution from humans or animals, are also expected to be absent (WHO (1993, p22) if the water has been properly chlorinated. The number of these organisms present in a 100ml sample of a source of water is often used to gauge its bacteriological quality.

Effective chlorination is not usually straightforward because there are a large number of variables that can affect the success of the disinfection. Some of these have already been mentioned. Others will be discussed in the following section in relation to potential operation and maintenance problems generally associated with chlorinators.

2.5 Some of the general problems arising with the use of chlorinators

Table 2 summarises the main variables affecting chlorination. In this section, we consider in more detail some of the most common problems that arise with chlorination of small water supplies. These points should be kept in mind when reading the descriptions of the various chlorination systems presented in Section 3.

2.5.1 Precipitates, crystallisation and scaling

The use of calcium hypochlorite and chlorinated lime can lead to problems, particularly with hard water. The formation of calcium carbonate is possible which can over time block orifices, so these

Table 2. The main variables affecting chlorination

	Variable	Comments
The nature of the water to be treated	Temperature	Usually the higher the temperature the faster the rate of disinfection
	pH (a measure of acidity/alkalinity)	pH should normally be <8.0 (see Section 2.1 & 2.4). If necessary, adjustment of pH adds complications to treatment processes.
	Turbidity	Turbidity should be as low as possible, certainly < 5 NTU (see Section 2.3) or it will adversely affect disinfection. Suspended solids can cause operational problems with some forms of chlorinator.
	Hardness	Although not directly affecting the process of disinfection, hardness can cause problems with the build up of deposits in drip feed chlorinators.
Flow rate of raw water	Constant continuous flow	All types of chlorinator can cope with this type of flow
	Constant but intermittent flow	The chlorinator must be of a type that stops automatically, or is always stopped manually, when flow stops.
	Batch volume	This is a fairly easy type of flow to chlorinate, particularly with small batches. Effective mixing of the dose with the water to be treated may be a problem with large batches.
	Variable flow	Simple chlorinators can not usually cope with this type of flow.
Availability, and correct use of chlorine compounds and testing equipment	Use of testing equipment	Correct use of appropriate test equipment is important for reliable chlorination. It allows adjustments of the dose to be made to compensate for many of the variables mentioned in this list.
	Availability	A reliable supply of chlorine compound is needed. If not presently available, it may be feasible to produce sodium hypochlorite from the small-scale electrolysis of salt (Appendix 2).
	Storage requirements and chemical stability of source of chlorine	Careful storage of chlorine compounds is necessary to reduce the rate at which chlorine is lost. Periodic testing will allow appropriate adjustments to be made to dosing.
	Accuracy of preparation of dilutions for doser	Care is needed to correctly prepare dilutions if these are necessary. Periodic testing is necessary to confirm accuracy.
	Associated compounds	Some chlorine compounds contain substances that may adversely affect some forms of doser. This is a potential problem with sources of chlorine that are used in the form of solids & powders.
	Handling precautions	Some compounds need more safety precautions than others.
	Transportation	Low concentration compounds have greater mass and volume.
Chlorinator and its operation	Type	The type of chlorinator needs to suit the flow pattern of the water that is to be treated. (See Section 3 & 4) Some types have specific constraints and operational problems.
	Accuracy	The doser needs to be accurate over the range of conditions it will operate under including changes in water level and pressure.
	Adjustment	The doser must be correctly adjusted (manually or automatically) to cope with the relevant variables mentioned in this table.
	Warning of malfunction	Sufficiently regular inspection of the correct operation of the doser is required to ensure that any malfunction is recognised before consumers are put at risk. Wherever possible, malfunctions should be avoided by preventative maintenance.
	Maintenance and repair	The doser must be correctly maintained to ensure continued accuracy. Spares must be readily available for preventive maintenance. A standby doser may be necessary to ensure continuing disinfection during planned maintenance or in the case of unexpected breakdown.
Contact time	Efficiency of mixing of dose with the water	The dosed chlorine needs to be efficiently mixed with the whole of the water to be treated. This may be difficult with batch treatment.
	Actual residence time in tank/pipe etc.	The design of 'contact tanks', or other methods of retaining the chlorinated water for a sufficiently long contact period, is important. Often 'short circuiting' in contact tanks results in retention times being shorter than expected.

need to be regularly inspected and cleaned. The formation of deposits can also occur at drip feed nozzles where the calcium in the solution can also react with carbon dioxide in the atmosphere to form calcium carbonate. Evaporation can also form deposits.

One way of reducing the build-up of deposits at drip feed nozzles is to totally enclose them in a small transparent chamber (through which the correct operation of the nozzle can be seen). A small vent hole should be provided at the top of the chamber, and at the bottom of the chamber there should be a pipe to carry away the dripped liquid. This pipe should terminate below the level of the water that is being dosed. (WRC, 1989)

When making a chlorine solution from solids or powders such as calcium hypochlorite and chlorinated lime, sufficient time must be allowed for the non-soluble solids to precipitate. Then the clear solution should be carefully decanted to be used for dosing. This avoids problems that may otherwise arise from the solids being carried into the chlorinator. As an additional precaution one can use a simple filter on the outlet from the tank which stores the dosing solution. This filter can be made from cotton wool inside a perforated container (Solsona, 1990). Small petrol filters, as used on automobiles, have also worked well (Solsona, 1981).

As sodium hypochlorite is already a liquid, it is more convenient to dose than calcium hypochlorite or chlorinated lime. When used undiluted it does not usually cause problems with dosing equipment. However, when it is diluted with tap water the sodium hypochlorite can react with hardness salts to form precipitates and scales. Crystallisation of sodium hypochlorite solution can also occur over a period of time if it comes into contact with air.

2.5.2 Corrosion

Chlorine is corrosive and the atmosphere around chlorinators is often damp so only corrosion resistant components should be used for chlorinators and associated pipework. Solutions of chlorine are extremely corrosive. For this reason glass, PVC, fibreglass, polyethylene, and certain other types of plastic or special rubbers are commonly used for chlorinators and their associated pipework. White (1986, p38) also specifically mentions use of Kynar, Saran, Kel-F, Viton and Teflon materials as being appropriate.

2.5.3 Availability and stability of chlorine compounds, and risks from additives

Wherever chlorination is being considered it is important that sufficient amounts of a suitable source of chlorine are available. In view of the fact that the chlorine content of some compounds reduces quite quickly it is best to avoid bulk deliveries that would cover many months of use. Where large deliveries are to be made the size of container should be carefully chosen to make handling safe and easy. The size chosen should also be such that the number of times which the container needs to be opened before it is emptied, and the effect of this opening and removal of the remaining contents, does not have a major adverse effect on the remaining material.

The type of container and the way in which it is stored has a major effect on chlorine compounds.

- *Sodium hypochlorite* at normal solution strength (10 – 14%) can be unstable, decomposition being particularly accelerated by heat and exposure to light (WRC, 1989). WRC (1984, Appendix 12) reports on laboratory tests carried out to measure the deterioration of various different strengths of solutions of sodium hypochlorite. These showed that if any concentration of solution is kept in a cool dark place it could maintain its strength fairly well for a period of several months rather than a period weeks suggested by some writers. Field tests should be carried out to determine an appropriate maximum 'shelf life' under particular production and storage conditions.

Household bleaches (usually about 1% chlorine) are diluted sodium hypochlorite. They can be used for disinfection but those that contain additives (such as perfumes) should be avoided.

- *Chlorinated lime* is also unstable. Exposure to light and moisture make the chlorine content fall rapidly.
- *Calcium hypochlorite* is more stable than either sodium hypochlorite or chlorinated lime. Powders are usually pure. Tablets are made almost entirely of calcium hypochlorite but have trace additions of materials to prevent powdering and to stop moisture being absorbed too readily. However, like the other compounds, they should still be stored in airtight containers in a cool, dry place.

Tablets that are designed for chlorination of swimming pools may have additives (such as cyanurate compounds) that make them unsuitable for chlorinating drinking water, particularly in the long-term (Williams, 1983).

In view of the deterioration of these compounds with time it is important that all stock is used in order of date of manufacture.

2.5.4 Handling precautions and transportation

Since chlorine compounds are corrosive they can burn skin. Hence gloves and sometimes other waterproof or dustproof clothing and eye protection will be necessary when handling them to avoid all accidental contact with the skin. Inhalation of concentrated gas or dust from these compounds should also be avoided. This means that the compounds should wherever possible be handled in a well-ventilated area. Care should be taken not to raise dust from powdered compounds, and as a precaution, a dust mask and goggles should be worn by an operative when s/he is handling powders.

In view of the risks that arise from handling it is preferable to choose chlorination systems that require a minimal amount of handling and diluting procedures. Manufacturers' instructions should of course always be followed.

Transportation of the compounds also needs to be arranged carefully to ensure safety and so that the material is protected from unnecessary deterioration. Low-concentration solutions and powders will of course mean that larger and heavier volumes need to be transported. In one part of Bolivia, the problems of regularly transporting a 1% solution of hypochlorite to a remote area discouraged rural communities from chlorinating their water (Lyhne, 2001).

2.5.5 Accuracy of preparation of solutions for dosing

Care needs to be taken when producing solutions ready for dosing and regular testing of the chlorine content of these solutions should be carried out. Adjustments can then be made to ensure that the chlorine concentration remains constant. (Variation in the strength of the solution may be acceptable if the rate at which it is dosed to the water being treated is adjusted to compensate, but it is easier for operatives to deal with dosing a constant-strength solution.)

If only periodic testing of the solution is possible the timing of the tests should take into account the following:

- The chlorine content of the compound used is likely to reduce over time. Hence, to obtain the same strength of solution, increased amounts of the compound need to be added to any fixed volume of water used for dilution. Alternatively the volume of dilution water will have to be reduced.
- The volume (or mass) of compound, and the volume of water it is added to, both need to be carefully measured each time a solution is prepared. Scales to weigh out powders are rarely used. Instead the powder is normally measured by volume which is related to a known mass.

- The chlorine demand of the water used to make the solution may need to be checked to see if it has any major effect on the level of available chlorine, particularly if the quality of this water changes.
- Adjusting dilutions to produce a consistent strength of solution may cause operative problems if they are not sufficiently numerate to carry out the necessary calculations. Use of numerical tables and charts may overcome this problem. To make adjustments the operative also needs to have appropriate equipment to accurately measure out a varying quantity of the compound, or a varying volume of dilution water.
- If there is any doubt about the preparation procedures or the effect of any changes, the strength of the resulting solution can be tested to check if it is of the right strength. This checking is accomplished by measuring the amount of free residual chlorine in the solution. The 'Modified Horrock's Method' can be used to make up a solution of known concentration without prior knowledge of the chlorine content of the chlorine compound (Parr *et al.*, 1995). It involves making trial dilutions in separate containers and then, after 30 minutes, testing for residual chlorine in the water in each container.

Box 3. Calculations for preparing solutions and applying chosen doses

Assume that the concentration of chlorine in a compound as a percentage ($C_1\%$) by mass is reliably known. Then the necessary mass (M_1 grams) of it that should be added to a known volume of water (V_2 litres) to produce a desired concentration of solution ($C_2\%$) can be readily calculated from the equation:

$$M_1 = ((C_2 \times (1000 \times V_2))/C_1 = (1000 \times V_2 \times C_2/C_1)$$

For example to determine the mass of bleaching powder, with a strength of 20% chlorine by mass ($C_1 = 20$) that needs to be added to 50 litres of water ($V_2 = 50$) to produce a 0.5% solution ($C_2 = 0.5$), the equation is:

$$M_1 = (1000 \times 50 \times 0.5/20) = 1250 \text{ g,}$$

so 1250 grams of the powder has to be added to the 50 litres of dilution water to produce a 0.5% solution

Note that a 0.5% solution contains 5 g of chlorine per litre of water = 5000 mg/l = 5000ppm

The volume (V_2 litres) of a solution of known strength ($C_2\%$) which needs to be added to each litre of water to be treated, to give a required dose ($C_3\%$) can be calculated from the equation:

$$V_2 = C_3/C_2$$

So if a dose of 5 mg/l ($C_3 = 0.0005\%$) is required, and the 0.5% solution ($C_2 = 0.5$) is being dosed, the required volume (V_2) per litre will be given by:

$V_2 = 0.0005/0.5 = 0.001$ litre (= 1 ml) of 0.5% solution needs to be added to each litre of water to be treated to apply a dose of 5 mg/l.

As mentioned in Section 2.5.1, precipitates may form when solid chlorine compounds are used to produce dosing solutions. These should be allowed to settle so that only clear solution can be decanted off for dosing. WRC (1989, p57) recommends that because bleaching powder is not very soluble that the solution made with it should not be stronger than 0.65% available chlorine by mass.

The equipment used for dose preparation should of course be resistant to the corrosive effects of the chlorine (Section 2.5.2).

2.5.6 Accuracy of the amount of solution dosed

It is obviously important that the designed volume of chlorine solution is dispensed into the water to be treated. The ease with which this can be checked depends on the type of chlorinator being used.

- For dosers that discharge through the atmosphere it is usually relatively easy to collect the discharge over a period of time and to measure its volume so that the corresponding dosing rate can be calculated. From the known strength of the solution and the known flowrate of the water to be treated the application rate of the dose can be calculated.
- For dosers that discharge into a close pipework system, such as the hydraulic motor doser and the venturi doser, an operative can make similar observations to find the rate at which the solution is being sucked into the doser from the vessel storing the solution.
- For either of the above options, an alternative is to use a small corrosion-resistant flowmeter, such as a rotameter, on the pipe that is dosing the solution. Such a meter will visually indicate the flowrate of the solution flowing from the tank. However, it needs to be kept clean if it is to give reliable readings.

2.5.7 Accuracy of the estimate of the flowrate of the water to be treated

The amount of solution that needs to be dosed will depend on the quantity of water to be treated. Chlorinators that dose in proportion to the flowrate need to be used if the flowrate is variable.

- If the water to be treated is stationary as in the batch treatment system (i.e. when the contents of a whole tank of water are treated) the volume of water to be treated can be found by calculating the amount of water in the tank.
- Where the water is flowing it will be necessary to know its flowrate. This could be based on a water meter reading but the meter will need to be well maintained to ensure accuracy.
- One method to calculate the flowrate in a pumped system is to observe the rate at which a tank fills or empties because of the flow of water. The flowrate in m^3/hr can then be calculated from multiplying the rate of fall or rise in the water level (in m/hr) and the plan area of the tank (in m^2).
- Where flow is exposed to the atmosphere sharp-edged triangular or rectangular notches can also be used. The depth of flow through such notches can be used to calculate the flow using formulae, graphs or numerical tables.

2.5.8 Mixing of the dose with the water to be treated

For chlorination to be successful, all of the water to be treated must come into contact with the disinfectant for at least the required contact time. It is therefore important that at the start of the contact period the dose is already fully mixed with the raw water.

With constantly flowing water the dose can be added at a constant rate directly into the water flowing in a pipe or channel, or just as it enters the contact tank. It will then be well mixed throughout the water.

Where the dose is being added to a large volume of relatively stationary water it is more difficult. In such a case, the dose should be added at a number of different points, and then the contents of the tank or well should be agitated ensure full mixing of the dose. In an open well, raising and lowering a bucket through the whole depth of the water many times is a good way to agitate the water.

2.5.9 Ensuring effective contact time

The importance of contact time has already been discussed in Section 2.4. Successfully achieving this period of contact after the chlorine dose has been well mixed with the water is not as straightforward as it may at first appear. Various publications, such as WRC (1989, p75 –77) and WRC (1984, p47 – 55), offer advice on the design of contact tanks. The important feature is that there should be 'plug flow' through the tank so that there are no areas of static or near-static water. Hence flow in a long straight pipe or narrow channel is ideal. Square or circular tanks are not very good shapes for contact tanks unless they are divided up with vertical walls that ensure that the incoming water can not cross directly from the inlet to the outlet. These dividing walls should ensure that all of the water slowly follows a longer winding path before it leaves the tank. A weir, or high level outlet, should be provided to maintain a fixed volume of water in the contact tank. Otherwise, at low water levels, the contact period will be insufficient. The high level of the outlet means that the tank can not be used as a storage reservoir.

A storage tank can be used as a contact tank if the outlet is closed whilst it is being filled with well mixed chlorinated water. When the tank is full the contents should be left undisturbed for the contact time, after which water can be withdrawn for supply. If two storage tanks are provided these can be used alternately.

Sometimes, sufficient contact time can be provided whilst the water is flowing in the water supply pipework between the dosing point and the start of the distribution system. This is possible if the first position at which water can be drawn from the pipe is sufficiently far away from the chlorinator that the flow time exceeds the required contact time. However, this point may be some distance from the point of treatment. With such an arrangement it is necessary to take samples from the first water collection point on the distribution system to monitor the achievement of the required residual. A shorter length of large diameter pipe at the start of the distribution system, positioned straight after the dosing point is an alternative. However flow at the inlet to this larger diameter pipe must be effectively distributed across the whole of its cross sectional area.

2.5.10 Testing for chlorine concentration

The first objective of effective chlorination is to ensure that an acceptable chlorine residual (usually a free chlorine residual) exists after the contact time. The physical arrangement of the system should be designed to prevent water being consumed before this period had elapsed.

A second objective is often that the chlorine residual is sufficient to protect the water from any minor sources of contamination it may encounter as it flows through the distribution system. It should also prevent the growth of nuisance bacteria and other organisms in the pipework. Monitoring the achievement of this second objective means that in addition to any testing directly after the contact tank, the water needs to be periodically tested at other points in the distribution system, particularly those that are far from the point at which the chlorinated water enters the system. A free chlorine residual of at least 0.25 mg/l may be required to prevent the growth of *Aeromonas* and other nuisance bacteria (WHO, 1993, p137).

It is important that testing for residual chlorine in drinking water is carried out with sufficient frequency to ensure that chlorination is being successfully accomplished.

For measuring high strength concentrations, such as sodium hypochlorite, it may be necessary to first carefully dilute the sample with demineralised water. This complicates the testing procedure and can be a source of error unless the operatives of small-scale systems are well trained.

The standard methods of field-testing for chlorine concentrations in water are well explained elsewhere, but are briefly introduced in the following paragraphs.

- The most convenient method for measuring 'residual chlorine' is the **colorimetric method** that uses DPD (diethyl paraphenylene diamine) tablets that are dissolved in a measured sample of the water. The extent of the red colour change resulting in the sample is judged visually in comparison to a scale of standard colours that relate to specific concentrations. It is important that the test is completed as rapidly as possible (less than 20 seconds after dissolving the tablets) to prevent the reagent acting on the combined chlorine. Small, cheap, simple 'comparators' accurate to within about 0.1 ppm are available. Different tablets are available either to measure the 'free residual chlorine' or the 'combined residual chlorine'. Since pH has an important effect on chlorination (see Section 2.1) some comparators are designed to also allow measurement of the pH of the water. This is done by adding a different reagent tablet, usually 'phenol red', to a separate sample of the water. The colour change of this sample is also measured but against a different colour scale.
- Another approximate method for testing for chlorine residual based on colour change is the use of the starch-potassium method Hutton (1983, p82) and Solsona (1990, p10). Although this is a cheap method it needs careful and regular (e.g. fortnightly) preparation of the reactive solution. This makes it less suitable for small treatment installations. Since this test is not specific for *free* residual chlorine (Solsona, 1990, p9) it has limited application.

The ortho-tolidine method previously used for measuring chlorine concentrations is no longer promoted because of the carcinogenic nature of this substance.

Some suppliers of testing equipment are listed in Appendix 1.2. Simple test strips that can be dipped into chlorine solutions to measure their chlorine content can be used. However, these do not seem to be available for accurately testing the low residual concentrations normally aimed at in chlorinated water. They can be used to check sodium hypochlorite strength or the strength of some dosing solutions.

2.5.11 Changes in water level and water pressure

Where a powered chlorinator sucks the dose from a tank of solution located below the pump it is important to check that any change in the level of the surface of the solution does not adversely affect the dosing rate. Tests carried out by WRC (1984) on a number of water-powered and electrically-powered dosers discovered that some were very sensitive to changes in this level difference which will occur as solution is consumed. The effect was more marked when the pumps were discharging at low pressure.

Where a pump is discharging into a pressurised pipe, changes in the water pressure in the pipe can affect the dosing rate.

Both of these effects are much more pronounced with diaphragm pumps (WRC, 1984 p34-36) because of unwanted changes in the deflected shape of the rubber diaphragm. The change in dose with change in pressure in the discharge pipe is a particular problem with solenoid operated pumps, but since these pumps are electrically powered they are not considered in this present report for the reasons given in Section 1.1.

A simple way to avoid any changes in the suction head is for the suction pipe to the chlorinator to draw solution from a tank in which the level remains constant. This can be achieved by drawing the dose from a small intermediate 'constant-head' tank (see Figure 3.3.5 a & b). This tank is filled from a larger tank in which the bulk of the solution is stored. The discharge pipe from the large tank to the small one passes through a float valve that controls the surface level of the solution in the small tank.

As discussed in Section 3.2, dosers that rely on gravity discharge usually have 'constant head' devices to compensate for changes in the surface level of the solution as it is used up.

2.5.12 Provision of on/off features and anti-siphon valves

Some of the chlorinators described in this report are not suitable for intermittent flow unless flow from the chlorinator is always stopped manually when the flow of water to be treated ceases. The dosers that are powered by water will stop automatically when flow ceases. However, precautions may still need to be taken to ensure that solution does not continue to flow out of the chlorinator, or that water does not begin to flow into the chlorinator or solution tank.

3. Chlorinators for small systems

3.1 Introduction

The literature search identified only a few detailed publications relating to chlorinators suitable for operation where there is no reliable supply of electricity.

The best publication on small-scale chlorination is 'Disinfection of rural and small-community water supplies – A manual for design and operation' WRC (1989). This manual describes 12 different types of doser ranging from pot-chlorinators to electrically powered dosing pumps and also includes the vacuum gas chlorinator.

Some of the WRC manual seems to be based on earlier experimental work (WRC, 1984) in which 17 specific chlorinators were tested. Of these 17 only 8 were not powered by electricity. WRC (1984) is the only source of data found relating to the comparative testing of chlorinators. The author of this present report also found it hard to obtain information about the advantages, disadvantages and accuracy of any simple dosers used in the field. WELL will be pleased to receive any information of this nature that can be added to any future editions of this report.

Solsona (1990) provides brief but useful information about a number of dosing devices. A few of them are of types not mentioned in the WRC (UK) publications. For example he describes two simple gravity devices that can each be made from an inverted bottle. He also describes another gravity device called the 'vandos chemical feeder'. He includes a new category of device namely 'wheel feeders' of which he gives two examples.

In the following sections brief details are supplied about the different chlorinators with references to further sources of information about them. Many of the devices are illustrated in Figures 3.1 – 3.4 found in Appendix 3. Contact details for suppliers of specific systems that were located during the literature search are listed in Appendix 1.1 but neither WELL nor the author is in a position to be able to endorse any of them.

The suitability of some systems will depend on whether or not the water is flowing and whether or not the flow is constant or is variable. This is summarised in Table 3.

The devices mentioned in the following sections have been divided into three categories:

- **Gravity driven chlorinators** – where the chlorine solution being dosed flows through the device naturally, as a result of the force of gravity
- **Water-powered chlorinators** – where moving water powers a mechanical device, or produces a reduced pressure, which is used to dose the chlorine solution into the water
- **Diffusion chlorinators** – where water picks up a chlorine dose by coming into contact with solid or powdered forms of a chlorine compound

Note that not all the water to be treated has to receive a dose of chlorine direct from the chlorinator. Sometimes just a proportion of the water receives a high dose of chlorine solution from the chlorinator, but this water is then thoroughly mixed with the remainder so all of it becomes chlorinated.

3.2 Gravity-driven chlorinators

With all of these units precautions need to be made to avoid sediments or scale forming since this will disrupt their performance (see Section 2.5.1).

3.2.1 Mariotte Jar

The Mariotte jar is also termed a 'constant-head aspirator'. Each version uses a large (e.g. 20-litre) sealed, rigid bottle that contains the chlorine solution. The jar is equipped with an air inlet pipe, and an outlet pipe to discharge the chlorine solution. As shown in Figure 3.2.1 in Appendix 3 there are three arrangements possible for this device.

The side-outlet version of the Mariotte jar (Figure 3.2.1a) is the commonest type. It uses a small-diameter vertical inlet pipe (e.g. 10mm) that passes down into the jar through an airtight bung. A separate, capillary tube (e.g. 0.8mm) which passes through the side of the bottle, near its base, acts as the outlet pipe. As liquid leaves the bottle through the capillary tube air bubbles into the jar through the air inlet pipe. The difference in level between the bottom of the air-filled pipe and the discharging end of the capillary tube controls the rate of discharge, independent of the depth of liquid in the bottle. This height difference can be controlled, by raising or lowering the air pipe. Alternatively, if the outlet pipe is made with a 90° bend, positioned outside the jar (as illustrated in Figure 3.2.1a), the height difference can be adjusted by rotating the outlet pipe. However for good drip formation and to reduce crystallisation the angle of the outlet pipe should be less than 45° from the horizontal (WRC, 1989).

If the outlet pipe from any of the designs of jars includes a portion of flexible pipe this allows easy changes in the level of the discharging end of the pipe. A flow control valve can also be fitted to this pipe (see Figures 3.2.1 b & c).

WRC (1984) provides some useful information about the laboratory tests on the performance of such a system and these are summarised in the later WRC manual. WRC (1984) states that the smallest reliable delivery rate is 1 litre/day. During tests it was noticed that changes in atmospheric pressure and temperature could cause temporary disturbances to the discharge rate.

Both WRC publications show an adaptation to the standard Mariotte jar that can be used to stop flow automatically when the raw water to be dosed stops flowing. In this arrangement a flexible pipe is run from the top of the air inlet pipe to near the top of a small mixing tank into which the raw water and the dose both discharge. A float valve controls the raw water inlet to this tank. If the outlet flow stops then the water level in the tank will rise, closing the valve. The end of the hose is positioned so that the water level needed to close the valve covers the end of the pipe. This prevents air entering the Mariotte jar, thereby stopping flow. However, this on/off control will not be instantaneous.

The comments previously made in about precipitation and scale (Section 2.5.1) are particularly relevant to the Mariotte jar because of the danger of the small diameter outlet pipe becoming obstructed. The bottle should of course be shaded to prevent light causing the solution to weaken (see Section 2.5.3)

3.2.2 Inverted bottle with water seal

Solsona (1990, p 17) briefly mentions the use of a doser made from an inverted 10 – 15 litre bottle that is positioned with its open end submerged in a small container (Figure 3.2.2). The pipe outlet from the container has a valve on it that is set so that the required discharge dose is obtained when the liquid level in the container is just above the mouth of the bottle. As the liquid slowly drains out of the container the end of the bottle is soon exposed. This allows some air to enter the bottle causing some of the liquid it contains to flow into the container. The liquid flowing into the container will re-adjust the level in it, maintaining a reasonably constant pressure head at the valve, ensuring a fairly constant rate of discharge.

Solsona states that this device is 'widely used in many rural areas' but does not mention its accuracy. Like with the Mariotte jar, the bottle, and container that supports it will need to be rigid and protected from light.

3.2.3 Constant-head tanks

If the pressure (or 'head') at an orifice or valve remains constant, then as long as there are no external physical changes, the free discharge through it into the atmosphere will remain constant. Constant-head tanks use a sensitive corrosion-resistant float valve to ensure that the level of the solution in a tank remains constant to provide a uniform pressure at a valve or orifice on a pipe connected to the tank (Figure 3.2.3). The orifice size is chosen to be suitable to discharge the required flow at the available head. Fine adjustment of the discharge is possible by raising or lowering the orifice in relation to the fixed level of the solution in the tank. An alternative to the orifice is to use a valve, such as a needle valve, that can be finely adjusted to achieve the required flowrate. It is best if the orifice or valve is not positioned right at the end of the pipe because contact with the air at this point may cause scale to develop. Simpler, less accurate, controls can consist of devices that squash a flexible outlet pipe to form a constriction.

3.2.4 Inverted bottle with floating valve

Solsona (1990 p 20) describes a simple doser that he designed from an inverted plastic bottle and plastic cup (Figure 3.2.4). This bottle is a form of the constant-head tank just described.

To make the device, a soft piece of rubber about 10mm thick is glued to the bottom of the cup. Then the bottom is cut off the bottle to allow the cup to be inserted upside down in it so that it will float on the chlorine solution that will partly fill the bottle. The bottom of the inverted bottle is sealed using a vented cover through which a vertical inlet pipe, such as the casing of a ballpoint pen, projects into the bottle. A flexible pipe connects the top of this inlet pipe to a storage tank that contains the chlorine solution. A piece of pipe is also fitted in the downward pointing mouth of the bottle to allow the solution to slowly drain out through a flexible plastic tube. A simple discharge control device is provided on this pipe (Solsona uses a wing nut and a hinge that are used to progressively squash the tube to control the flow.)

When the level of the chlorine solution in the bottle rises the cup will float up, pushing the rubber against the inlet to close off the incoming flow. This effectively controls the water level in the bottle ensuring that there is a fairly constant pressure at the valve, to provide a reasonably constant discharge.

As with the other transparent bottle systems the bottle should be shaded.

The inventor claims that this dosing system is suitable for dosing between 0.1 and 10 litre/hr, with an error of less than 10%. He recommends that a filter be provided on the outlet from the storage tank to ensure that any suspended matter can not enter the system.

3.2.5 Floating draw-off

One simple method of providing a constant discharge is to provide a floating inlet in the chlorine solution tank. This inlet is connected to a flexible discharge pipe that passes out of the tank near its base (Figure 3.2.5). Although the surface level of the liquid in the tank will change as the solution is discharged, since the float moves down with the level of the chlorine solution, the depth of liquid above the inlet to the discharge pipe will remain constant, ensuring a constant discharge.

With the *floating orifice* version (Figure 3.2.5b) it is important that the discharge pipe does not act like a siphon. This is prevented by passing the upper end of the pipe vertically through the float to terminate above the surface of the solution. The inlet to the pipe is a hole in, or connection

to, the side of this pipe, a short distance below the float. Varying the depth of the inlet below the float, ballasting the float so it floats deeper in the water, or changing the size of an orifice on the side of the pipe, will allow a particular discharge rate to be set. The WRC manual reports that this system can be adjusted to deliver down to 'a few tens of litres per day'. USAID (1982a) includes design details for a floating orifice chlorinator.

With the float system just described it is important that discharge pipe should not flow full-bore. This must be avoided to ensure that the flow is controlled only by performance of the inlet to the pipe, which is subject to a constant head. There should not be a flow-controlling valve on the outlet end of the discharge pipe since this is likely to cause the pipe to fill up. If this happens, the height difference between inlet and the level of the valve will begin to control the flow. This will result in a variable flowrate because the inlet is moving down as the solution is being dosed. Incidentally the design of the constant head dosing kit described in Luff (2000) is not ideal because there is no vent pipe shown and the text speaks of using a valve as one of the options for regulating the flow. Solsona (1990, p19) also suggests use of a regulatory valve on the discharge pipe where it leaves the tank. The author of this present paper recommends that such a valve is not used for regulating flow but only as an on/off control.

Devices that use a '**floating bowl**' are also promoted (USAID, 1982 a & b). In such a system a bowl containing two vertical pipes passing through its base is floated on the surface of the tank that contains the solution to be dosed (Figure 3.2.5a). One of the pipes is quite short and it allows the solution to flow into the bowl. The other pipe, connected to a flexible pipe that passes through the side of the tank near to its base, drains out any solution that enters the bowl, and discharges it to where it is to be mixed with the raw water.

The flow into the bowl for the *raised inlet type* depends on the height difference between the top end of the short pipe in the bowl and the water level outside the bowl. To change the flowrate the projecting length of the short tube can be adjusted by sliding the tube through a seal in the base of the bowl.

For the *drowned inlet type* the flowrate depends on the difference in water level inside and outside the bowl. To change the flowrate for this type the projecting length of the outlet pipe is adjusted.

For both types, another way of changing the flowrate is to add/remove ballast to/from the bowl so that it floats higher/lower in the water. A good way of doing this is by adding/removing small stones to/from a plastic bag held in the bowl. The upper end of the short tube can be above or below the end of the tube that drains the bowl but there is less likely to be problems with encrustation if it is below the outlet.

With all the float systems discussed in this section care needs to be taken to ensure reliable performance. For example, the float needs to be kept clear of the sides of the tank that contains the solution. If it touches the side of the tank as the solution is withdrawn this may slow up its constant rate of descent. This will reduce the distance between the inlet and the surface of the solution, which will change the pressure at the inlet, and hence the discharge through it. To keep the float central, some devices use one or more nylon guide strings (USAID, 1982a), or a plastic pipe guide stem (Luff 2000 p12), that pass through a pipe sleeve in the float/bowl.

If the flexible discharge pipe below the float/bowl is too stiff it can begin to tip the float/bowl as it descends resulting in a change in head at the inlet point. The tipping can also create sufficient friction on the float guides to cause a non-uniform rate of descent of the float. Similarly the coiling of the pipe as the liquid level falls can also adversely affect the rate of descent.

The orifice and pipes need to be kept clean of scale and sediments.

3.2.6 *Vandos chemical feeder*

Solsona (1990 p21) describes the 'Vandos chemical feeder', an interesting chlorinator that was developed in South Africa. It uses two identical, vertical cylindrical drums. The first drum is fixed in position and is initially filled with water that flows into the second drum at a controlled rate through a flexible pipe. The second drum is not fixed but floats in a tank that contains the chlorine solution. As the water flows into the second drum it becomes heavier, so it sinks into the solution tank, displacing an equal volume of solution. This solution flows out of a high-level outlet to the dosing point. Although during operation the water level in the first drum drops, it is falling at the same rate as the inlet to the second drum is sinking, so this maintains a constant level difference, and hence a constant flowrate. The rate of flow can be adjusted by either altering the initial height difference between the two points, or by adjusting a control valve (or replacing an orifice) at the inlet to the second drum.

Periodically the water in the second drum is transferred back into the first drum and the tank is refilled with chlorine solution.

This is an interesting device but no information is provided about its performance in the field. It has the potential advantage that the flow control system between the two drums does not have to be resistant to chlorine solution and will not block with precipitates or scale, something that can occur with a chlorine solution (see Section 2.5.1).

3.3 Water-powered chlorinators

There are several types of water-powered chlorinators. Some such as the *wheel feeder* are suitable where the water is flowing in a channel. Others like the *float-powered* system are used at a point where water is discharged from a pipe or channel. *Hydraulic motor-powered* systems and *venturi* systems require the water to be flowing in a pipe, either by gravity or because it is pressurised by a pump. *Direct suction* dosers make use of the reduced water pressure on the suction side of a pump that is already being used to pump the water that needs treating.

3.3.1 *Wheel feeder dosers*

This type of dosers is powered by a paddle wheel that is positioned in a channel through which the water to be treated is flowing. The flow of the water in the channel rotates the paddle, which rotates a shaft to which the chlorinator is connected.

Solsona (1990 p21) makes brief mention of an '*Archimedes wheel*'. This consists of a horizontal shaft with spokes connected to it. At the end of each spoke is a small container at right angles to the spoke, facing in the direction of rotation. As the shaft rotates, each container passes through a shallow tank of chlorine solution, picking up some of the liquid. As a container approaches the top of its circular motion the liquid it contains is automatically poured out. A tray is positioned to catch the discharge and direct it into the water flowing in the channel. Since the speed of rotation of the shaft depends on the amount of water flowing in the channel the rate of dosing will be related to the rate of flow of the water to be treated. A similar device developed in Swaziland in 1966 is described in Schulz and Okun (1984, p80-83).

Solsona also describes a different Colombian device that the author of this present paper has termed *a hollow-spoke wheel feeder* (Figure 3.3.1). It uses a near-horizontal pipe as the shaft, with two or three short pipes connected perpendicularly to it. The short pipes are like spokes but are fixed at different points along the shaft. As the shaft rotates, in turn each of the pipes is almost completely immersed in a tank containing the chlorine solution and the solution enters the pipe through the holes in the side of the pipe. Each pipe is sealed at end furthest from the shaft

so that most of the liquid that enters the pipe will remain in it as the spoke leaves the solution. When the pipe moves above the horizontal position the liquid it contains flows into the shaft that has a slope of 3 – 5%. This slope causes the liquid to flow along the shaft until it reaches a discharge orifice above the water that needs to be chlorinated. As with the previous system, if paddles drive the shaft, the dose will be approximately proportional to the flow in the channel. The level of the solution in the tank through which the pipes pass is kept at a constant depth by a float valve on an inlet pipe that is connected to a larger tank containing prepared solution.

3.3.2 Float-powered chemical doser

An interesting self-powered chemical doser is based on a 150 litre water tank fitted with a special fast acting siphon which rapidly empties the tank when it fills to a certain level (WRC, 1984, p15-17), WRC (1989, p62-64) and Schulz & Okun (1984, p82-84). Ball floats, operating in vertical guides, raise and lower a small dosing cup as the water level in the tank changes (Figure 3.3.2) . When the floats are at their lowest point the cup is submerged in a small tank containing the chlorine solution. As the floats rise, they lift the cup out of the solution and push it onto a displacement plunger, causing some of the solution to flow out of the cup, through a small weir. The weir discharges into a small hinged dispensing tube that directs it into the tank. The solution is discharged from the tube just before the siphon starts to empty the tank. The length of displacement plunger is adjustable to vary the dose.

Wallace and Tiernan manufacture this unit. It is able to cope with flowrates of between 0.1m³/hr and 4m³/hr. The flowrate of raw water through the doser is limited by the discharge rate of the siphon. For flows higher than 4 m³/hr the doser can be fitted on a bypass that takes only a proportion of the flow, as long as subsequently the dosed water is thoroughly mixed with the untreated water.

3.3.3 Hydraulic motor/piston driven dosers

Some enclosed dosing systems that are driven by water are available. The mode of operation of these usually ensures that the rate of dosing is reasonably proportional to the flow of water through them. Such dosers that can be of various types (e.g. reciprocating piston or diaphragm pump). Some of them use an electronic sensor system to control the doser but this type is not considered in this publication.

Two types of water-powered mechanisms are available to operate this category of doser. In one type, the water to be treated drives a small motor (like a water meter) that rotates a shaft that operates the piston or diaphragm. The second type (Figure 3.3.3) uses the water to drive a piston that moves back and forth in a valved cylinder. The reciprocating movement of the drive piston operates a displacement pump that doses the solution. These systems can raise the solution from below the pump and can inject it into a pressurised stream of water. Most types can be adjusted within a certain range, to provide a specific ratio between the volume of the dose and the volume of the water passing through the unit.

Where the flow of water to be treated is large, a smaller capacity doser can be used on a bypass pipe through which a proportional amount of the flow is diverted. However, if the flow rate is variable, the ratio between the diverted flow and main flow should be investigated to check that it is fairly constant otherwise the incorrect dose may be applied. The bypass flow needs to be thoroughly mixed with the main flow where the two flows merge again.

3.3.4 Venturi-powered dosers

When water flows through a constriction in a pipe the velocity of the water increases and its pressure reduces. The difference between the upstream pressure and the pressure at the constriction can be used to automatically draw chlorine gas, or a chlorine solution, into the pipe

(Figure 3.3.6). If the reduced pressure created at the constriction is less than atmospheric pressure then a single small diameter pipe connection at that point can be used to suck solution into the pipe (Figures 3.3.4 & 3.3.5b). Such devices are variously called ejectors, injectors, eductors, aspirator feeders or vacuum drawing systems. A sudden change in cross section such as an orifice can be used to form the constriction. More usually, as in a venturi, the change in section is more gradual when approaching and departing from the constriction (Figure 3.3.4). The pressure difference caused is proportional to the flowrate, and with a suitable arrangement this will result in the dose automatically changing to suit the flowrate. With high flowrates the venturi device can be fitted on a bypass that is designed to automatically take only a fixed proportion of the total flow. When the two streams are brought back together the chlorine dosed into the bypass water will be mixed with the other water.

Some venturi devices are fixed in parallel to the main pump that pumps the water into a distribution system or storage tank (Solsona, 1990 p23). In this arrangement the inlet to the device is from a small branch connection to the outlet pipe (i.e. delivery side) of the pump and the outlet from the device is to a branch on the inlet pipe (i.e. suction side) of the pump (Figure 3.3.5b). Valves are used to adjust the flowrate through the doser to ensure that the water that passes through it delivers sufficient dose for all of the water that is being pumped. This type of doser is only appropriate if the pump main and storage provided before the distribution system gives sufficient contact time.

3.3.5 Direct suction dosers

These rely on a single, small diameter connection to the suction side of a pump that is already being used to pump the water that needs treating (Solsona, 1990, p24). The suction pressure at that point is used to suck the solution into the water (Figure 3.3.5a). A valve on the small-diameter pipe can be used to adjust the dose. The solution should be sucked from a constant-head tank so that the static suction head remains the same. Two non-return valves are also likely to be needed. One of these is to stop the solution siphoning out of the tank into the suction pipe of the pump when the pump is not in use. The other valve stops water in the pumping main flowing back into the solution tank when the pump stops.

Luff and Hoque (1997) describe the development of a small suction-powered device designed for use with a suction handpump. This would only be appropriate if the water was not consumed until at least 30 minutes after it was collected from the pump.

3.3.6 Displacement-bag doser

This doser may also be called a 'displacement doser' or a 'diaphragm displacer' (WRC, 1989, p65-66). The latter term should not be confused with a 'diaphragm pump', which is a different type of doser. With a displacement doser the chlorine solution is contained in a flexible bag that is held within a closed vessel (Figure 3.3.6). The small diameter 'dosing pipe' passes from inside the bag, through the lid of the vessel and on to the discharge point. Another pipe, the 'supply pipe', passes only through the wall of the vessel to introduce water between the inside of the container and the outside of the bag. When the pressure of this water exceeds that of the solution in the bag it will displace solution out of the bag and into the dosing pipe. This differential pressure can be achieved in a number of ways. One way is to install an orifice plate on the pipe containing the water to be treated. Then the supply pipe is connected upstream of the plate and the dosing pipe is connected downstream of the plate. Alternatively the pipes can be connected to the appropriate points on a venturi constriction on the raw water pipe (Figure 3.3.6).

Periodically the bag is refilled from a tank containing a prepared chlorine solution whilst the water outside the bag is drained out of the vessel.

The volume of solution displaced from the dosing bag will equal the volume of water entering the vessel so a small flowmeter (e.g. a rotometer) can be fitted on supply pipe and a valve can be used to adjust the flow to provide the required dose. This position for the flow meter is better than placing it on the dosing pipe where it will be subject to the corrosive disinfecting solution.

This doser does not have to always be used with a venturi system. The author of this present report sees no reason why the water that is used outside the bag to displace the solution can not gravitate from any constant-flow system. For example a gravity-driven chlorinator (Section 3.2), could potentially be used with plain water to provide the displacement water. Such a gravity-driven device will not be subject to the effects of corrosion and scaling that it would experience when chlorine solution is flowing through it. The chlorine solution only comes into contact with pipework downstream of the bag.

3.4 Diffusion chlorinators

In diffusion chlorinators the chlorine is in the form of a powder or tablets which come into contact with the water that is to be dosed. Some of these chlorinators are used in fairly stationary bodies of water, such as open wells, whereas others are designed for situations where water flowing through the unit dissolves the tablets.

For treatment of drinking water the tablets used should be of pure sodium hypochlorite or a mixture of this and an approved binding medium. Some tablets are designed to avoid water being absorbed through the tablet by capillary action. This prevents water seeping up a stack of tablets, adversely affecting ones that are not yet in contact with the water to be chlorinated. Chemicals in some of the tablets used for chlorination of swimming pools make them unsuitable for long-term use for disinfection of drinking water. However, it may be possible to use simple swimming pool dosers with tablets designed for potable water systems.

3.4.1 Pot chlorinators and floating chlorinators

For many years pot chlorinators have been promoted for disinfection of open wells. They consist of a covered container, such as a pot, which contains a mixture of coarse sand and chlorinated lime (bleaching powder) or calcium hypochlorite (see upper diagram in Figure 3.4.1a). The pot, which is suspended in the well, contains a few holes, either above the level of the mixture or at the level of a bed of fine stones placed below the mixture (USAID, 1982a). The expectation is that the chlorine in the powder will combine with the water that seeps into it and that this solution will leave the pot, via the holes, to mix with the water in the well. The ratio of chlorinated lime to sand that is recommended in different publications varies from 1:1 to 1:3.

Instead of a pot Solsona (1990, p14) describes the use of two concentric uPVC tubes with the inner one tightly fitting the outer one. The inner one, which contains the mixture, is sealed at the bottom and has a removable cover at the top. This cylinder has a mesh covered slot in its side and the outer cylinder is used to cover over part of the slot to allow a level of adjustment of the dose. Solsona (1990, p13) also describes a perforated plastic bag system that is used in China to contain the mixture of sand and chlorinated lime. The use of a porous pot that is filled with only chlorinated lime or calcium hypochlorite is also mentioned.

Some systems use a double pot arrangement (see the lower diagram in Figure 3.4.1a) where the inner container that contains the mixture is put inside another container that is also perforated (Heber 1985, p62-64).

Luff (2000, p13) mentions the use of a 'floating pot chlorinator', similar to that used in some swimming pools. It contains a vertical stack of large tablets made from a chlorine compound that slowly dissolves in the water. Adjustable slots are used to limit the entry/exit of water/solution into/out of the unit. Providing a vertical cylinder of the right size for the tablets, and supporting it in

any floating object, will produce a similar unit (Figure 3.4.1b). Adjusting the length of the submerged portion of this cylinder will adjust the applied dose. One Caribbean system used a tyre inner tube as a float (Lewis, 1987). The bottom of the cylinder used in this device is open but has a lip on its edge to stop the tablets falling out. This arrangement also allows the indissoluble portions of the tablet to fall through so that they do not remain to obstruct the descent of the stack of remaining tablets. An alternative is to fix a coarse plastic mesh, or nylon threads, across the bottom of the cylinder.

As Solsona (1990, p12) mentions, attitudes about the effectiveness of pot-chlorinators vary. Their performance can be very variable because the mixture of sand and powdered chlorine compound can combine to become fairly solid and impermeable to water. Also the holes in the container and the pores in a porous pot can become quickly blocked with calcium deposits. Work done by NEERI in India in the 1980's found that adding sodium hexametaphosphate (5% by mass) to the chloride of lime prolonged the release of chlorine because it prevented the powder/sand mixture solidifying. WRC (1989 p54-57) discusses chlorination of wells and the authors report that a double pot chlorinator that used sodium hexametaphosphate (7.5% of the mass of the chloride of lime) was found to give satisfactory performance in rural areas of Portugal.

One doubt about pot and floating chlorinators is whether or not the chlorine solution they produce will be sufficiently mixed with the remainder of the water in the well to provide sufficient dose to all of the water. A second doubt is whether or not sufficient residual time will pass before the water is consumed.

Where a tank that can be isolated from the supply is being used it may be possible to provide sufficient time to ensure effective disinfection using a pot chlorinator. However, making a liquid dose from the chloride of lime and distributing this at various points in the tank is likely to be far more effective than using a single pot or floating chlorinator.

In open wells, where the water is being withdrawn at various rates throughout the day, the effectiveness of diffusion chlorinators is very doubtful. In such wells, particularly those where individual buckets and ropes are used to withdraw water, pathogens can enter the well at any time, and they can be almost immediately withdrawn again.

The presence of a chlorinator in a well may give people a false sense of security about the quality of the water. It is important that as far as is possible the well is protected from contamination (Section 1.2.2), and that people who collect the water from it do not subsequently contaminate what they collect (Section 1.2.3). If feasible, household-level treatment may be the best method of ensuring proper disinfection of water collected from an open well (see Sections 1.2.2, 1.2.3 & 4.2.1).

A chlorinator in an open well can be broken if it is hit by one of the buckets that is used to collect water. It should therefore be protected. Alternatively users need to take special care not to hit it with their bucket.

Overnight, when a well is not in use, chlorine will continue to diffuse into the water, albeit at a slower rate than when the water is being stirred-up by buckets. This can mean that in the morning the odour or taste of the water may be unacceptable to users. This is also sometimes the case when a freshly re-charged pot chlorinator is first installed in a well.

3.4.2 Continuous flow diffusers

Continuous flow diffusers are similar to the floating chlorinators just described but are designed so that water flows across and through a perforated section at the bottom of the vertical cylinder to slowly dissolve the tablets it contains (WRC (1989)). They are also called 'erosion tablet

feeders'. Many of the available systems use large calcium hypochlorite tablets (e.g. 75mm diameter). The dose applied to the water by these systems will usually be higher than that required for disinfection, so the unit is usually positioned on a bypass that takes only a portion of the flow of water to be treated. After the unit the two streams are mixed together again. Some diffuser units have four separate columns of tablets, or a large diameter cylinder containing many smaller diameter tablets. The latter design can allow a large volume of water (e.g. as much as 200m³/day) to flow across the tablets to receive a fairly high dose of chlorine.

If the depth of contact with the tablets is constant, then as the flowrate increases so does the rate of dissolution of the tablets, increasing the total amount of chlorine taken into solution per minute. Some systems (Figure 3.4.2) use an outlet weir so that the water level in the unit rises as the flowrate increases, resulting in a greater depth of water coming into contact with the tablets and hence a higher amount of chlorine going into solution per minute. Manual adjustment of the depth of tablet(s) submerged in the flow can be achieved on some systems. This is accomplished by either by raising or lowering the cylinder.

Most tablet erosion systems are un-pressurised but in at least one system the flow can be pressurised. This system uses a vertical glass cylinder to contain the tablets. At the base of the cylinder are two vertical pipe connections, one to admit water to the bottom of the cylinder and the other to let it out again. The dose can be adjusted by pumping air into the cylinder to reduce the space in the cylinder for water to flow through the tablets.

WRC (1984, p30-31 and Appendix 4.16) extensively tested one type of erosion tablet feeder. They discovered that the tablets they used tended to erode irregularly leading to a variable dose in the steady flow. This was particularly the case when an eroded tablet crumbled away and a new tablet came into use. The behaviour of different types of tablet may vary depending on the binding agent (if any) used so if possible tests should be carried out with tablets from different suppliers to find which is best. However, using a large contact tank may successfully average out the effects of any short term variations in the dosing rate.

3.4.3 Intermittent flow diffusers

The erosion tablet feeders just described are not suitable where the water flow is intermittent. This is because the water remaining in the unit when the flow stops will become very highly dosed with chlorine, potentially causing problems when the water begins to flow again. To avoid this problem a 'tipping tray chlorinator' was developed by one manufacturer (WRC, 1989, p53).

In this type of chlorinator the water to be dosed flows into a pivoted tray positioned directly below the cylinder containing the tablets. The bottom of the stack of tablets only comes into contact with the water when it fills the tray to a certain level. Shortly afterwards, the continuing rise in the water level causes the tray to become unstable and it tips over, discharging its contents. The empty tray then tips back to begin to fill again. When the flow stops, if the water is not yet in contact with the tablets, it will all remain in the tray. If it is in contact with the tablets this situation does not last for very long because there is a small drainage hole in the side of the tray which soon drains water out to a level below that of the tablets.

The author of this present report has been unable to locate details of any current manufacturer of this type of chlorinator.

Table 3. A comparison of small-scale chlorinators against certain selection criteria

Key to symbols and letters used in boxes:
 ✓ – yes, √ – probably - ? – unlikely, ✖ – no
 l – low, m – medium, h – high

Selection Criteria	Gravity driven						Water-powered						Diffusion		
	Mariotte jar	Inverted bottle	Constant-head tank	Inverted bottle + valve	Floating draw-off	Vandos feeder	Wheel feeder	Float-powered	Hydraulic drive	Venturi systems	Direct suction	Displacement bag	Pot / floating units	Continuous flow	Intermittent flow
Needs moving water for power or for tablet erosion	✖	✖	✖	✖	✖	✖	✓	✓	✓	✓	✓	✖	✖	✓	✓
Suitable for dosing into flowing water	✓	✓	✓	✓	✓	✓	✓	✓	✓	✓	✓	✓	✖	✓	✓
Suitable for intermittent flows of water	✓	✖	✖	✖	✖	✖	✖	✓	✓	✓	✓	✓	✖	✖	✓
Suitable for dosing at high rates	✖	✖	✓	✖	✖	✖	✓	✓	✖	✖	✖	✖	✖	✓	✓
Suitable for dosing against water pressure	✖	✖	✖	✖	✖	✖	✖	✖	✓	✓	✖	✓	✖	✖	✖
Can be made locally	✓	✓	✓	✓	✓	✓	✓	?	✖	✓	✓	?	✓	✓	?
Spares supply for moving parts may be a problem	✖	✖	✖	✖	✖	✖	✓	✓	✓	✓	✖	✓	✖	✖	✖
Level of skills required for major maintenance tasks	l	l	l	l	l	l	m	m	h	m	m	l	l	l	l
Needs calcium hypochlorite tablets	✖	✖	✖	✖	✖	✖	✖	✖	✖	✖	✖	✖	✖	✓	✓

4. Selection of chlorinators

4.1 Selection criteria

There are a variety of selection criteria appropriate to the choice of a chlorinator for a small water treatment system where electrical power and chlorine gas are not going to be used. These are discussed below by posing important questions that need to be answered before an appropriate choice can be made. Table 3 and Table 4 and the text in Section 2 and 3 of this report give the necessary background detail to assist with making any particular choice.

4.1.1 Nature of the flow of the water to be treated

- **Is the water relatively stationary or is it flowing?** Water-powered chlorinators and some diffusion chlorinators require flowing water to operate.
- **Is the flow constant or variable?** Some dosers can automatically compensate for changes in flow rate but many can not.
- **Is the flowrate continuous or intermittent?** Continuous, constant flow is usually the easiest situation to cope with, other than if the chlorinator has to discontinue operation when it is being refilled or maintained. Having a standby unit that can be brought into operation whilst the other is being maintained is a good idea if the flow of water can definitely not be stopped during the maintenance period, although this situation is rare. If flow is continuous and the dosing is interrupted then obviously some of the water will not receive the correct dose of chlorine. However, it may be possible to divert this water to waste. If flow periodically ceases, some chlorinators will automatically stop, others will have to be turned off manually. With some units valves are needed to stop siphoning taking place when flow stops (Section 2.5.12)
- **Does all of the water have to pass through the unit or should a bypass be used?** With high flowrates it may be necessary to divert only part of the flow through the chlorinator. This water is then dosed with a high concentration of chlorine before it is diverted back, to be thoroughly mixed with the remainder of the water. Care needs to be taken when using a bypass, to ensure that the proportion of flow diverted through the unit remains constant, particularly if the flowrate is variable.
- **What dosing rate per hour is required?** Some chlorinators can only dispense small doses of solution, which makes them only suitable for disinfecting water with low flowrates. This problem is compounded if only low strength solutions are available for dosing. Although use of more than one chlorinator in parallel will increase the total rate of dosing, use of a different type of chlorinator may be the better choice.
- **Does the flow need to remain in a pipe or can it be open to the atmosphere?** In some situations the dose needs to be added to flow in a pressurised pipe. Only a few types of chlorinators are suitable for this.
- **Is the chlorine demand of the water constant?** None of the chlorinators described in this report can automatically adjust for changes in the dosing rate to cope with changes in the chlorine demand of the water. It is therefore important that a chlorinator operator tests the concentration of free residual chlorine (in the water leaving the contact tank) whenever s/he suspect there is a change in the quality of the raw water. Adjustments to the dose should then be made if necessary.

4.1.2 Origin of the doser and its operation/maintenance requirements

- **Is the doser produced locally or is it imported?** If an imported chlorinator is to be used it is important that a reliable supply of affordable, essential spares is readily available. Because

small chlorinators are not widely used it may be hard to find in-county agents able to supply such a service. If this is the case enough spares for several years operation, or even for the whole life of the chlorinator, may need to be purchased when it is initially imported.

- **What are the operational and maintenance requirements of the doser?** The level of skills of both the operators of the chlorinator and the technical staff who may support them should be matched to the complexity of the operation and maintenance tasks. Training and monitoring of performance will often be necessary to ensure that operators carry out effective chlorination.

4.1.3 Types of chlorine compound available

- **What form of chlorine is available?** Different forms of chlorine, sodium hypochlorite, chlorinated lime, calcium hypochlorite, liquid, powder, tablets, etc. may determine what types of chlorinator are feasible.
- **Is the supply of the chlorine compound reliable?** In view of the potential, fast deterioration of some chlorine compounds, effective chlorination will often require a regular and reliable supply of chlorine compounds (Section 2.5.3). If it is properly stored calcium hypochlorite has the longest shelf-life of the compounds discussed in this report, but for many chlorinators it will first have to be dissolved to prepare a solution ready for dosing. The calcium content of chloride of lime and calcium hypochlorite may cause problems unless regular maintenance takes place (Section 2.5.1).

4.1.4 Ability of doser to cope with changes in water level, solution level or water pressure

- **Will the doser be accurate under the conditions under which it will operate?** As mentioned in Section 2.5.11, certain chlorinators are adversely affected by changes in the surface level of the solution in the storage tank, in which case a constant-head tank need to be provided. Where the chlorinator is injecting the solution against a variable water pressure this may also adversely affect the dosing rate, particularly at low pressures. The manufacturer's guidance should be sought on this matter and the effect of changes should be observed when the chlorinator is installed.

4.2 Chlorinator options for different sources of water

The most appropriate choice of chlorinator will be partly dependent on the source of the water and the way in which it is collected or distributed. These aspects are discussed in the following sub-sections. Table 3 and Table 4 give guidance on the appropriateness of the various options for each source.

4.2.1 Open wells

As discussed in Section 3.4.1 successful chlorination of water from open wells is problematic. Unless the water is pumped from the well the usual choice is a diffusion device such as a pot chlorinator, but this may not be effective.

Another option is to use a constant-rate dosing device to drip-feed chlorine solution into the well at a suitable rate to match the average rate at which the water is being collected from the well. This is also unlikely to provide a very reliable dose, since it will tend to provide too little chlorine during periods of peak demand and too much during periods when the well is not in use. There also needs to be a way in which the device can be turned off overnight, or at other times of low water demand from the well.

The fact that the water in open wells is not flowing practically rules out use of most of the other chlorination devices. However, if the water is raised from the well using a suction handpump then a direct suction doser, fitted to the suction side of the handpump may be used (see Section

3.3.5). If it is feasible, household-level treatment will be another option (Section 1.2.3), which will require less chlorine solution because the householder can choose to only treat drinking water which seems more logical.

Any organic matter introduced into an open well will consume some of the chlorine meant for disinfecting the water. It is therefore important to keep the well water as clean as possible (Section 1.2.2).

Household-level treatment (Sections 1.2.3 & 1.2.7) is probably the most reliable method of treatment for water collected from wells.

4.2.2 Boreholes

Water in a properly constructed and maintained borehole that is equipped with a handpump or a mechanically powered pump is not prone to contamination by users. Chlorination is therefore only necessary if for some reason the groundwater is already polluted or to give some level of protection from contamination in a piped distribution system (see Section 2.1). If a motorised pump is raising the water, then a number of different types of chlorinator may be appropriate. In fact the situation is identical to that discussed below when treating pumped surface water except that other treatment processes to deal with turbidity, etc., will not be necessary.

Unfortunately the variable and intermittent nature of the discharge from handpumps usually means that any chlorinator positioned after the pump is unlikely to perform well. However, the suction device already described (Section 3.3.5) may be appropriate if users allow sufficient contact time before they consume the water. This system is not appropriate for deepwell handpumps because the suction side of the cylinder in these pumps will be below the container from which the solution will be drawn. This means that the solution will continue to siphon into the well even after pumping stops. Household-level treatment probably the only reliable method of chlorination where deepwell handpumps are used.

A constant rate drip-feed dosing device is not suitable for a handpump supply because of the intermittent use of the borehole. Potentially such a device could be used with a powered pumping system that pumps for a long period at a fairly constant rate, as long as the chlorinator can be turned off as soon as the pump stops. However, to be effective the chlorine solution needs to be delivered close to the intake to the pump, which is usually some distance below the water level. Delivery at this point may be achieved if the solution is dripped into an open pipe that runs down the inside of the borehole to a point near to where the water is entering it from the aquifer.

Some groundwater may contain chemicals such as iron that initially react with chlorine making less of the dose available for disinfection. The chlorine demand of the chemicals in groundwater should therefore be established before designing a chlorination system.

4.2.3 Springs

The water from a well-protected spring should all originate from groundwater. Often this will be safe and will not need any disinfection other than what may be desirable to protect it in a distribution system. Once the spring water has been channelled into a pipe a number of chlorination systems may be appropriate. These will be similar to those used for treating surface water for piped systems (Section 4.2.4).

The discharge of springs may be fairly constant although there may be some gradual seasonal variations that may require periodic changes in the dosing rate. If the discharge changes rapidly after rain it may indicate a risk that the spring is being polluted by surface water.

Table 4. Likely appropriateness of chlorinators for different water sources

Key to symbols used in boxes:
 ✓ – yes; ✓ – probably; ? – unlikely; ✗ – no

	Gravity driven						Water-powered						Diffusion		
	Mariotte jar	Inverted bottle	Constant-head tank	Inverted bottle + valve	Floating draw-off	Vandos. feeder	Wheel feeder	Float-powered	Hydraulic drive	Venturi systems	Direct suction	Displacement bag	Pot / floating units	Continuous flow	Intermittent flow
GROUNDWATER															
Open well - bucket withdrawal Dosing into well	?	?	?	?	?	?	✗	✗	✗	✗	✗	✗	?	✗	✗
Well or borehole – handpump withdrawal															
Connection to suction pipe before pump	✗	✗	✗	✗	✗	✗	✗	✗	✗	✗	✓	✗	✗	✗	✗
Dosing into well	?	?	?	?	?	?	✗	✗	✗	✗	✗	✗	?	✗	✗
Well or borehole – powered pump withdrawal pumping directly into distribution pipework															
Dosing into sealed pipework near to pump	✗	✗	✗	✗	✗	✗	✗	✗	✓	✓	✓	✓	✗	?	✗
Dosing into well	?	?	✓	✓	✓	✓	✗	✗	✗	✗	✗	✗	?	✗	✗
Well or borehole – powered pump withdrawal and pumping to elevated tank															
Dosing into sealed pipework near to pump	✗	✗	✗	✗	✗	✗	✗	✗	✓	✓	✓	✓	✗	?	✗
Dosing into well/borehole	?	?	✓	✓	✓	✓	✗	✗	✗	✗	✗	✗	?	✗	✗
Dosing at entry to tank	?	?	✓	✓	✓	✓	?	✓	✓	✓	✗	✓	?	✓	✓
Spring - gravity flow into pipework															
Dosing into pipework after spring box or storage tank	✗	✗	✗	✗	✗	✗	✗	✗	✓	?	✗	✓	✗	?	✗
Dosing into spring box or storage tank	✓	✓	✓	✓	✓	✓	?	✓	✓	✓	✗	?	?	✓	?
SURFACEWATER (after pre-treatment)															
Dosed into sealed gravity flow pipework	✗	✗	✗	✗	✗	✗	✗	✗	✓	?	✗	✓	✗	?	✗
Dosed into sealed pipe near pump	✗	✗	✗	✗	✗	✗	✗	✗	✓	✓	✓	✓	✗	?	✗
Dosed into flow in channel	?	?	✓	✓	✓	✓	✓	✓	?	✗	✗	✗	✗	✓	✓
Dosed at piped entry into contact tank or storage tank	?	?	✓	✓	✓	✓	?	✓	✓	✓	✗	?	?	✓	✓
RAINWATER (domestic systems)															
Stored rainwater many not need treatment. If it does, none of these methods are really appropriate. Batch treatment in domestic containers is probably the best option.															

Notes:

This table should be read in conjunction with the appropriate text in Sections 3 and 4.

Whatever dosing method is used it is important that there is sufficient contact time (Section 2.4)

For all of these sources batch treatment at some stage is usually an alternative option. For all sources, other than those using buckets or handpumps for water withdrawal, this can be carried out in tanks of known volume into which a predetermined chlorine dose is added. This tank can also conveniently act as the contact tank.

For all sources batch treatment at domestic level in household containers (Sections 1.2.3 & 1.2.7) is also an option.

If the spring provides more water than is required then a weir overflow system to divert excess flow can be used to ensure that only a constant flowrate is withdrawn for treatment. Treatment can then take place at a piped inlet to the contact tank, using either one of the gravity flow dosers to drip solution above the point of entry to the tank, or by directing some of the flow through a continuous-flow diffuser. Water-powered dosers are another option if they are readily available and can be maintained.

4.2.4 Surface water

Various aspects relating to chlorination of surface water have already been discussed in Sections 1.2.2, 1.2.4, 1.2.6 and 2.3. The discussion in these sections pointed out that raw surface water is usually of poor quality, with a variable chlorine demand. As such, before it is chlorinated, it usually needs additional treatment that includes at least a filtration stage. Without this stage it is possible that some pathogens will remain in the water, even if an acceptable free chlorine residual is available after 30 minutes contact time.

4.2.5 Rainwater

Rainwater from impermeable roofs of dwellings can be relatively pure and may not need chlorination. If it does, none of the chlorination devices discussed in this document are particularly suitable. This is because of the very intermittent and variable flowrate that results from the non-uniform rainfall pattern. If the rainwater is stored in a tank, then batch treatment in domestic containers filled from the tank is probably the best option (Sections 1.2.3 & 1.2.7). Batch treatment in the storage tank after each period of rain is possible but, because of the variable dosing required, this method is unlikely to be feasible at household level.

5. References and Bibliography

5.1 References

Craun GF (Editor) (1996) **'Water Quality In Latin America: Balancing the microbial and chemical risks in drinking water disinfection'** International Life Sciences Institute (ILSI) Argentina, Pan American Health Organisation and World Health Organisation, ILSI Press, Washington DC, USA

CDC (2000) **'Safe Water Systems for the Developing World: A handbook for implementing household-based water treatment and safe storage projects'** Centers for Disease Control and Prevention (CDC), United States Department of Health & Human Services, USA (Available on web page http://www.cdc.gov/safewater/manual/1_toc.htm)

EPA (1990a) **'Technologies for Upgrading Existing or Designing New Drinking Water Treatment Facilities'**, Technology Transfer Publication EPA/625/4-89/023, United States Environmental Protection Agency, Cincinnati, USA

Heber G (1985) **'Simple Methods for the Treatment of Drinking Water'** GATE, Friedr. Vieweg & Sohn Verlagsgesellschaft mbH, Braunschweig, Germany

Hofkes EH (Editor), Huisman L., Sundaresan B.B., De Azevedo Netto J.M. and Lanoix J.N., (1981) **'Small Community Water Supplies – Technology of small water supply systems in developing countries'** Technical Paper Series No. 18, International Reference Centre for Community Water Supply and Sanitation (IRC), The Hague, The Netherlands

Hutton LG (1983) **'Field Testing of Water in Developing Countries'** Water, Engineering and Development Centre (WEDC), Loughborough University, UK.

IWA (1983) **'Seminar on appropriate technology transfer in water supply and sanitation'** Papers presented a seminar held at Thohoyandou Hotel, Venda, 28-30 September 1983, Papers S.338, International Water Supply Association, South Africa

Lewis K (198?) **'Installation, Operation and Maintenance of a Floating Chlorinator'** Caribbean Basin Water Management Project, Montserrat Water Authority and Pan American Health Organisation

Luff R (2000) **'Instruction Manual for Coagulation and Disinfection Equipment – Covering upflow clarifier, chlorine and aluminium sulphate dosing options'** An Oxfam Technical Manual, Oxfam, Oxford, UK

Luff R and Hoque E (1997) **'Disinfecting tube-well water – the evolution of a new technology'**, Waterlines Vol. 16, No. 2, Intermediate Technology Publications, London, UK, pages 30 - 32

Lyhne A (2001) Personal correspondence with a Peace Corps fieldworker in Bolivia

Parr J, Smith M and Shaw R (1995) **'Chlorination of community water supplies'**, Technical Brief 46, Waterlines Vol. 14, No. 2, Intermediate Technology Publications, London, UK, pages 15 – 18 (Also in Shaw ed. (1999 p 53 – 56))

Pearson I, with Still D and van Vuuren V (2000) **'Field Evaluation of Alternative Disinfection Technologies for Rural Water Supply Projects'** Project K5/828, Water Research Commission (WRC), South Africa

Reed RH (1997) **'Solar inactivation of faecal bacteria in water: the critical role of oxygen'**, Letters in Applied Microbiology, 24:276 -280

Rojas R and Guevara S (2000) '**Electrolytic cells for in-situ production of hypochlorite**', An English translation of the Spanish paper 'Celdas electrolíticas de producción in-situ de hipoclorito de sodio' presented in 'Hojas de Divulgación Técnica del CEPIS, Numero 78, Junio 2000 (CEPIS' technical bulletin, number 78, June 2000) Lima, Peru

Schulz CR and Okun DA (1984) '**Surface Water Treatment for Communities in Developing Countries**' Wiley, UK (Reprinted by Intermediate Technology Publications, UK in 1992)

Shaw R (Editor) (1999) '**Running Water – More technical briefs on health, water and sanitation**', Intermediate Technology Publications, UK

SODIS (2001) '**SODIS Water Disinfection**' <http://www.sodis.ch/> (An informative page on solar disinfection on the Department of Water and Sanitation in Developing Countries (SANDEC) web site. SANDEC is part of EWAG, one of the Swiss Federal Research Institutes)

Solsona F (1990) '**Disinfection for small water supplies – A technical guide**' Division of Water Technology, CSIR, South Africa

Solsona F (1981) '**The bottle/glass and the beer can/spray can low-cost dosing systems for water disinfection or fluoridation**' an English summary of a Spanish report of research printed in the CEPIS document 'Investigación sorbe Desinfección de agua en abastecimientos rurales', Repidisca document 4307/C44/016447, CEPIS, Lima, Perú

USAID (1982a) '**Designing a Small Community Disinfection Unit**' Water for the World Technical Note No. RWS.3.D.4, Institute for Rural Water and National Environmental Health for Agency for International Development, USA.

Available at <http://www.lifewater.org/wfw/rws3/rws3d4.pdf>

USAID (1982b) '**Operating and Maintaining a Small Community Disinfection Unit**' Water for the World Technical Note No. RWS.3.O.4, Institute for Rural Water and National Environmental Health for Agency for International Development, USA.

Available at <http://www.lifewater.org/wfw/rws3/rws3o4.pdf>

Rojas R and Guevara S (2000) '**Celdas electrolíticas para la producción *in situ* de hipoclorito de sodio**' Technical Support Unit for Rural Basic Sanitation (UNATSABAR), presented in the XXVI International AIDIS (Interamerican Sanitary Engineering Association) Congress, December 2000, in Porto Alegre, Brazil

White GC (1999) '**Handbook of chlorination and alternative disinfectants**' (4th edition) John Wiley & Sons.

White GC (1986) '**Handbook of chlorination and alternative disinfectants**' (2nd edition) Van Nostrand Reinhold, New York.

WHO (1993) '**Guidelines for Drinking Water Quality, Volume 1, Recommendations**' Second Edition, Authorised Reprint 1995, World Health Organisation, Geneva, Switzerland

WHO (1998) '**Guidelines for Drinking Water Quality, Addendum to Volume 1, Recommendations**' World Health Organisation, Geneva, Switzerland

Williams PG (1983) '**Chlorination of small-scale water supplies**' A paper presented in (IWA 1983) Also published in Water and Sewerage Effluent No. 199 pp 19, 21-23 1984

Witt VM and Reiff FM (1996) '**Water Disinfection Technologies for Small Communities and Rural Areas**' in Craun ed. (1996)

WRC (1989) '**Disinfection of Rural and Small-Community Water Supplies - A manual for design and operation**' Water Research Centre (WRC), Buckinghamshire, UK (on behalf of WHO)

WRC (1984) '**Treatment and disinfection of small water supplies – Final Report 551-S, DWI0080**' Water Research Centre (WRC), UK. (Available from Foundation for Water Research, UK. See summary at <http://www.fwr.org/waterq/dwi0080.htm>)

5.2 Other books and papers

Solsona F and Pearson I (1995) '**Non-conventional disinfection technologies for small water systems**' WRC Report No 449/1/95, Water Research Commission, Division of Water Technology, CSIR, South Africa

EPA (1990b) '**Environmental Pollution Control Alternatives: Drinking water treatment for small communities**' Technology Transfer Publication EPA/625/5-90/025, United States Environmental Protection Agency, Centre for Environmental Research Information, Cincinnati, USA

WASH (1992) '**Disinfection for Rural Community Water Supplies in Developing Countries**' Technical Note, 8 pages, WASH, USAID, Arlington, Virginia, USA

5.3 Some sources of information about chlorination on the world-wide web

See Appendix 1 for some additional resources.

Committee Report: Disinfection at Small Systems – A survey of smaller water systems' disinfection practices in US water systems, 8 pages from an AWWA Journal article
<http://www.cepis.org.pe/acrobat/smalldis.pdf>

Back to basis guide to disinfection with chlorine, 16 pages. A basic introduction to the theory and practice of chlorination.

<http://www.cepis.org.pe/eswww/fulltext/repind55/backbasi/backbasi.html>

Designing basic household water treatment systems 5 pages (another source for reference USAID 1982a) <http://www.cepis.org.pe/eswww/tecapropiada/otrateg/waterwor/rws3d1.pdf>

Chlorine Chemistry Council. CCC is a business council of the American Chemical Council. This site has some pages that are designed to give the public some basic information about the use of chlorine. http://www.c3.org/about_ccc/index.html

Appendix 1.

Sources of Further Information

Appendix 1.1 Some suppliers of small-scale non-electrical chlorinators

Appendix 1.2 Some suppliers of chlorine testing and pH testing kits

Appendix 1.3 Some suppliers of equipment for the production of sodium hypochlorite from the electrolysis of brine

Appendix 1.1 Some suppliers of small-scale non-electrical chlorinators

These are the contact details of some of the manufacturers of non-electrical chlorinators likely to be suitable for small-scale chlorination. It is not an exhaustive list. Mention of specific manufacturers or products does not imply endorsement by WELL.

Dosatron International, Rue Pascal, B.P.6, 33370 Tresses (Bordeaux), France
<http://dosatron.com/English/doseurs/fonctionnement.html> e-mail info@dosatron.com
 Supplier of a range of water-powered proportional dosers

MSR Dosiertechnik GmbH, Auf der Kaulbahn 6, D-61200, Wölfersheim, Germany
<http://www.msr-dosiertechnik.de/Neue%20Seiten/home.html> e-mail msr@msr-dosiertechnik.de
 Supplier of a variety of proportional dosers driven by water flow

Dosmatic USA Inc., 1230 Crowley Circle, Carrollton, TX 75006, USA
<http://www.dosmatic.com/products/a10.htm> e-mail info@dosmatic.com
 Supplier of a variety of proportional dosers driven by water flow

Turati s.a.s., Via F.lli Cervi, 37, 37010 S.Ambrogio di Valp. (VR0) Italy
http://www.turati.com/dosatori_uk.html e-mail turati@turati.com
 Supplier of a water-powered doser but little information about it is provided on the web page.

Paterson Candy International Ltd., 632/652, London Road, Isleworth, Middlesex, TW7 4EG, UK
<http://www.patersoncandy.com> e-mail contact for simple dosers greenp@bv.com
 Although not clear from the web site PCI apparently still manufacture some constant head 'gravity solution feeders' and a displacement doser ('Chemidoser') that uses a solution filled bag.

USF Wallace & Tiernan, Priory Works, Tonbridge, Kent, TN11 0Q, UK
<http://www.usfwt.co.uk/homepage.html> e-mail inform@usfinternational.com
 Supplier of liquid and gas dosing systems for chlorination that seem are mainly relevant to large treatment works or those with electrical power. However they also supply the self-powered chemical doser described in Section 3.3.2 (contact

Portacel (part of TM Products), Winnall Valley Road, Winchester, Hampshire, SO23 0LL, UK.
<http://www.portacel.co.uk/systems/dosing> e-mail portacel_sales@tmproducts.com
 This company supplies equipment for chlorination systems for conventional large treatment works. However, the ejectors it supplies can be used for schemes where there is no electrical power.

PPG Industries Inc., One PPG Place, Pittsburgh, PA 15272, USA
http://www.ppg.com/chm_calhypo/accutab.htm e-mail akuhn@ppg.com
 Suppliers of the Accu-Tab tablets used in continuous flow diffuser. (Hammond Technical Systems is its authorised manufacturer of dosing systems for use with these tablets that allow large volumes of tablets to be in contact with the water are available.

Hammonds, 15760, West Hardy Road, Suite 400, Houston, Texas 77060, USA
<http://www.hammondscos.com/water/products/index.asp> e-mail info@waterchlorination.com
 A company that produces dosers for use with the PPG Industries' Accu-Tabs. Some of their systems allow a very large number of tablets to be in contact with the water to be dosed.

Exceltec International Corporation, 1110 Industrial boulevard, Sugar lane, Tx 77478, USA
http://www.sanilec.com/products/chemicals/chemicals_tablet.html e-mail exceltec@sanilec.com
 A company specialising in large treatment systems but it also supplies small 'erosion tablet feeders' (i.e. a continuous flow diffuser) the largest of which has four tablet feed tubes. They supply 'Aquaward' tablets for use in the tablet feeder.

Appendix 1.2 Some suppliers of chlorine testing and pH testing kits

These are the contact details of some of the manufacturers of testing equipment likely to be suitable for small-scale chlorination. It is not an exhaustive list. Mention of specific manufacturers or products does not imply endorsement by WELL.

Camlab Limited, Nuffield Road, Cambridge, CB4 1TH, UK

<http://www.camlab.co.uk> e-mail: info@camlab.co.uk

In addition to the normal testing kits they supply test strips for chlorine

Palintest Ltd., Sales office, Palintest House, Team Valley, Gateshead, Tyne & Wear, NE11 0NS, UK

<http://www.palintest.com> e-mail: palintest@palintest.com

A supplier of various chlorine and pH test kits

Merk Ltd., Merk House, Poole, Dorset, BH15 1TD, UK

<http://www.merk-ltd.co.uk> e-mail: uk.sales@merk-ltd.co.uk

In addition to normal test kits it supplies test strips for chlorine

Appendix 1.3 Some suppliers of equipment for the production of sodium hypochlorite from the electrolysis of brine

These are the contact details of some of the manufacturers of electrolysis equipment likely to be suitable for small-scale chlorination. It is not an exhaustive list. Mention of specific manufacturers or products does not imply endorsement by WELL.

AquaChlor, Equipment & Systems Engineering, Inc., 14260 S.W. 136th St. Unit #4, Miami, FL 33186, USA

<http://www.aquachlorese.com> e-mail info@aquachlorese.com

Operation and maintenance of this equipment is well described on a sub-pages of the site:

<http://www.quakepro.com/aqua/index.htm>

Gaia Tech Limited – Italian branch. Dr Giovanni del Signore, Via San Matteo in Arcetri, 25, 50125, Firenze, Italy

e-mail delsignore@dada.it

This firm also promotes the Aquachlor equipment (see above). It is also promoting a small hand-powered or bicycle-powered electrolysis units that use a mechanical generator.

Bio Chlor (pty) Ltd., PO Box 78584, Sandton, South Africa, 2146.

<http://www.biochlor.co.za> E-mail: fouchel@biochlor.co.za

Sanilec, Exceltec International Corp., Sugar Land, Texas, USA

<http://www.sanilec.com> e:mail exceltec@sanilec.com

Clorid, Av. Gonzalez-Suarez 4-121 y Octavio Diaz, Cuenca, Ecuador

<http://www.clorid.com> e-mail clarid@cue.satnet.net

Dip Cell, Magneto-Chemie B.V., Calandstraat 109, 3125 B.A. Schiedam, The Netherlands

The Centre for Environmental Health Engineering, University of Surrey, UK, has carried out some comparative testing of electrolysis units. Contact Brian Clarke (e-mail address B.Clarke@surrey.ac.uk)

The MIOX system that uses mixed oxidants from the electrolysis of brine may be of interest to some readers. These oxidants are directly injected into the water to be treated and are more effective at disinfection than chlorine (see Section 1.2.8).

MIOX Corporation, 5500 Midway Park place, NE, Albuquerque, NM 87109

<http://www.miox.com>

Appendix 2.

Production of Sodium Hypochlorite by Electrolysis of Brine

As mentioned in Section 1.2.7, recent developments have meant that manufacture of sodium hypochlorite from the electrolysis of salt solution is now often feasible on a relatively small-scale. This means that where electricity (grid or solar) is available it is now possible to decentralise the production of sodium-hypochlorite to regional or sub-regional centres. This makes the reliable supply of a source of chlorine to the more remote areas of a developing country much more feasible than previously, when it was only available from importers or from the industrial centres in the cities.

The electrolysis of brine is used as a cost-effective source of sodium hypochlorite in some of the Safe Water System projects mentioned in Section 1.2.3. These often use a 3% brine solution made with ordinary salt (CDC, 2000). Individual electrolysis units are available in different sizes suitable for different production rates. The simplest ones consist of a small cylindrical unit, containing the electrodes. This unit is submerged in a covered, but ventilated vessel that contains brine made from dissolving a fixed amount of common salt in a fixed amount of clear water. The unit is then connected to the power supply for a sufficient time to electrolyse the brine to produce a solution of dilute sodium hypochlorite of the planned strength (e.g. 0.6% chlorine). If the unit is unattended, a simple timer to stop the process at the correct time can control the power supply to the electrodes. When sufficient time has elapsed the unit is removed from the solution and the electrodes are immediately rinsed. Impurities both in the salt and in the water used in the brine can accumulate on the cathode within the generating cell. To remove these deposits the generating cell is placed in a weak acid for a few minutes, after which the whole unit is rinsed with water. White vinegar (acetic acid) or a 3% solution of hydrochloric (muriatic) acid are suitable acids.

For large populations more than one unit can be run at one time. The sodium hypochlorite produced can be transferred to larger containers for transportation to community treatment works or into small bottles (less than 500ml) for use at domestic level. One inventor is promoting a mechanically powered unit (see Appendix 1.3).

Rojas and Guevara (undated) compared the performance of electrolysis units from four different manufacturers, to produce a 6% sodium hypochlorite solution.

Pearson *et al.* (2000) report on the monitoring of the field performance of several types of chlorine generators available in South Africa. The smallest of these installations was for a piped supply system serving 2500 people. In all of the systems electrolysis of brine was used but some systems were designed to produce chlorine gas and other oxidants instead of sodium hypochlorite. In each case production was found to be more cost effective than alternative sources of chlorine.

Some sources of information about of electrolysis units are listed in Appendix 1.3.

Appendix 3.

Simplified Illustrations of Chlorinators

This Appendix includes simplified drawings of most types of gravity-powered and water-powered chlorinator. Since there is no space in this short report to fully describe or illustrate them, readers are encouraged to obtain further details from manufacturers or from the references mentioned in Section 3 of this report.

The following drawings should be examined in conjunction with the descriptive text in the appropriate part of Section 3. The figure number below each drawing relates to the section number of the corresponding descriptive text.

KEY The following key will aid understanding of the drawings:

- h – ‘head’ difference driving the doser
- st – storage tank for the solution to be dosed
- ct – ‘constant head’ tank
- c – flow of the chlorine solution
- w – flow of water that has not been dosed with chlorine
- d – flow of water that has been treated (dosed)
- f – flow control device (may also act as on/off valve)
- v – on/off valve only, not for flow control
- o – one way valve (i.e. non-return valve)

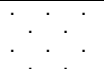
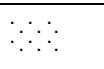
	water that has not been treated with chlorine
	chlorine solution
	water that has been treated with chlorine

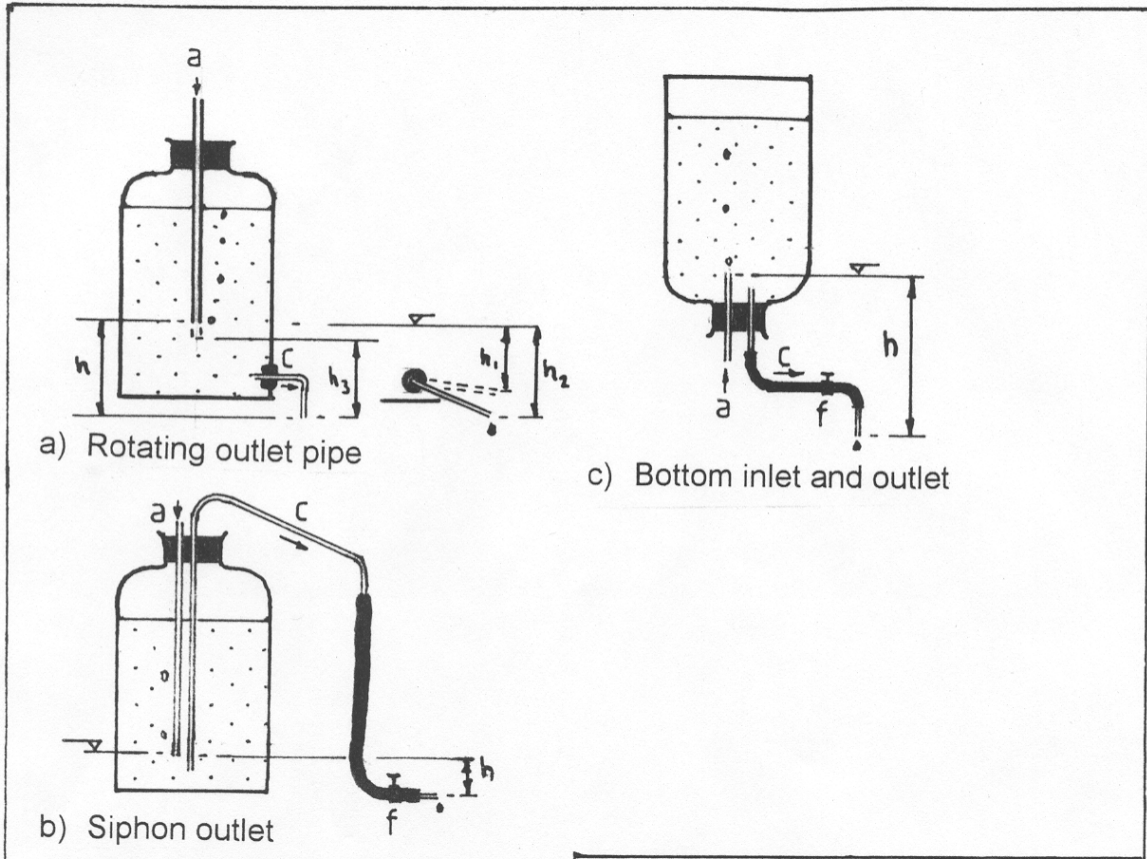

3.2.1 Mariotte Jar

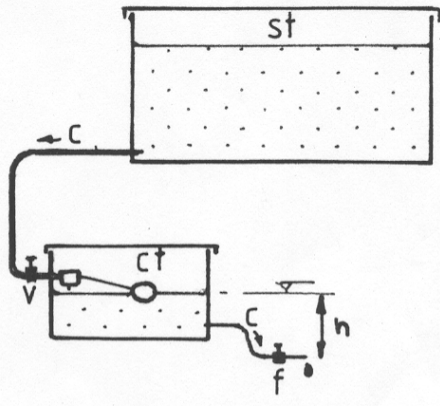
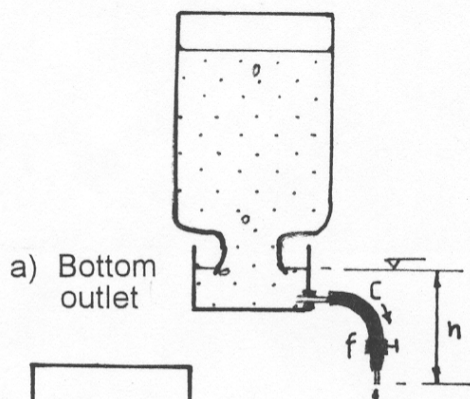

3.2.2 Inverted bottle

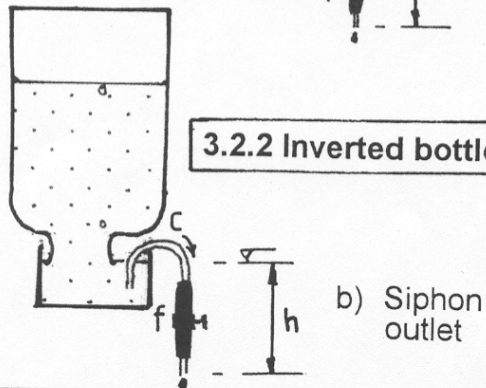

3.2.3 Constant-head tank

3.2 GRAVITY-DRIVEN CHLORINATORS (Page 1 of 2)

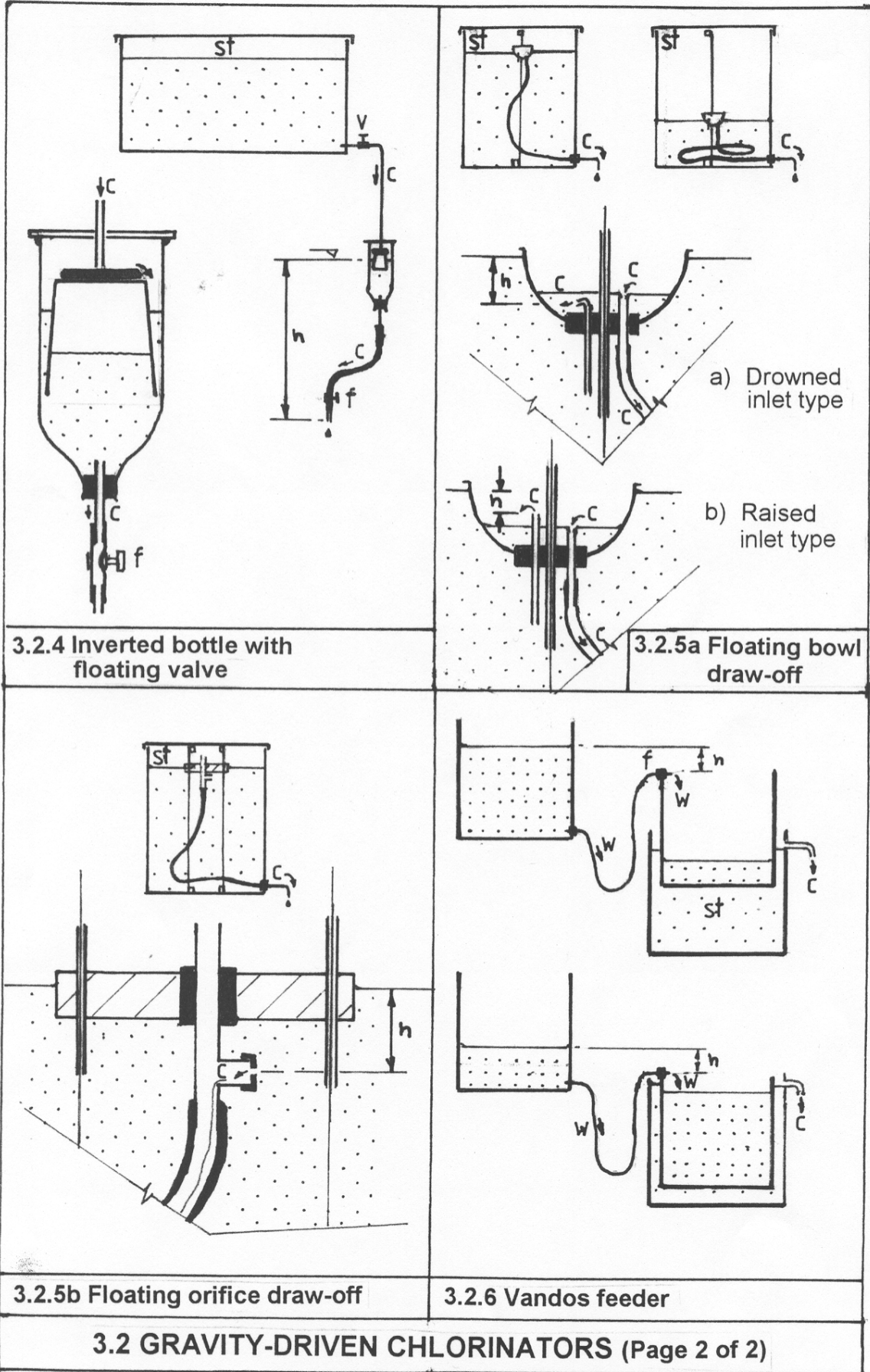

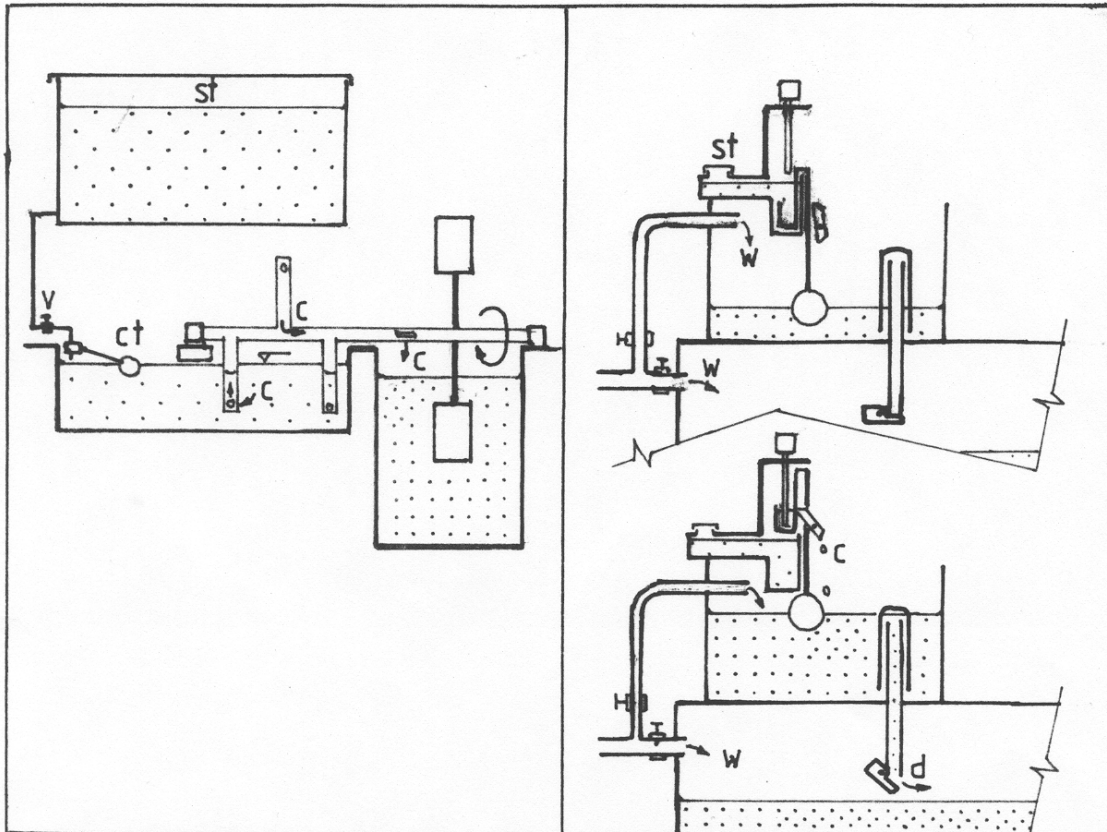

3.3.1 Hollow-spoke wheel feeder

3.3.2 Float-powered

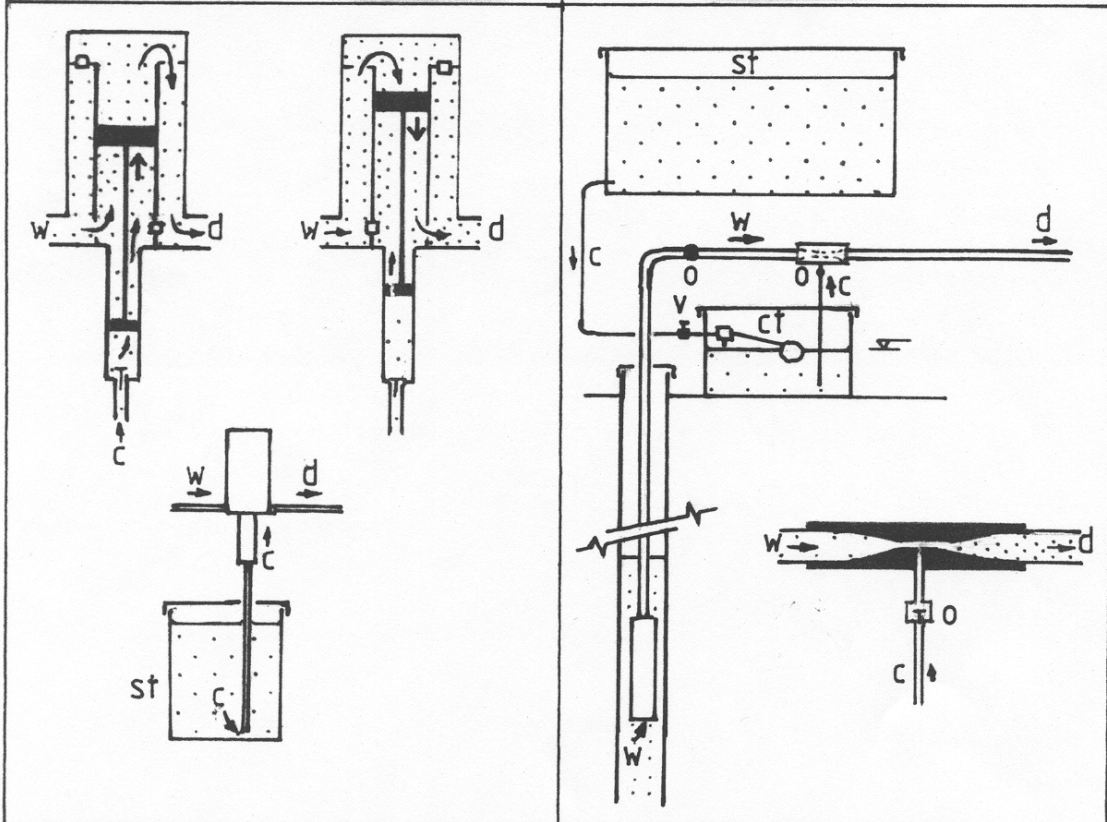

3.3.3 Hydraulically driven piston

3.3.4 Venturi-powered (also 3.3.5b)

3.3 WATER - POWERED CHLORINATORS (Page 1 of 2)

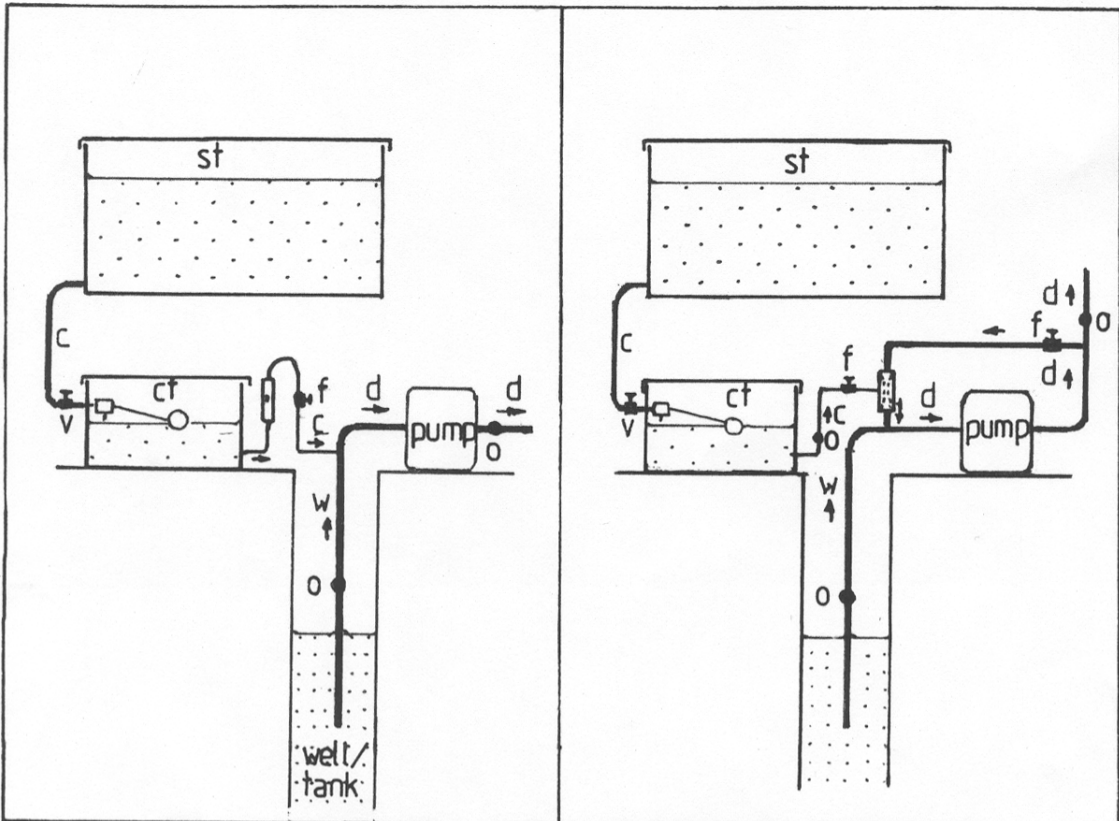

3.3.5a Direct Suction

3.3.5b Suction + Venturi

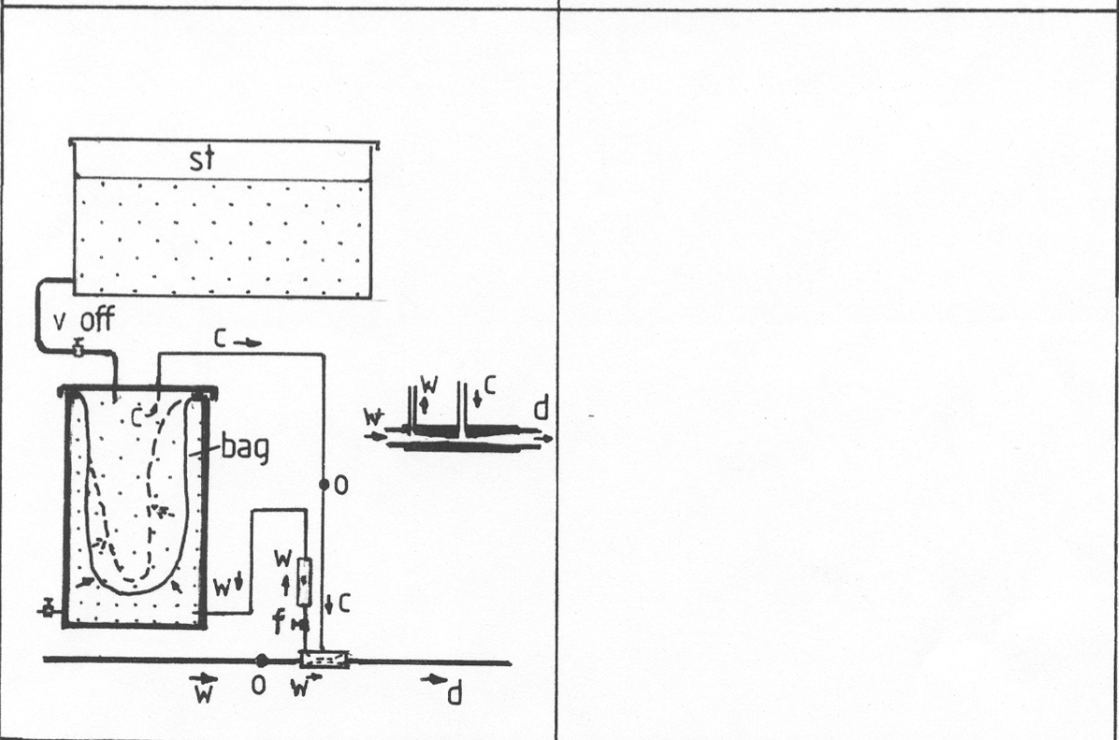

3.3.6 Displacement bag

3.3. WATER - POWERED CHLORINATORS (Page 2 of 2)

